

EDI MODEL 2018EClip-NC CONFLICT MONITOR PROGRAMMING DETAIL

(remove jumpers and set switches as shown)

REMOVE DIODE JUMPERS 1-5, 1-6, 1-9, 1-11, 2-5, 2-6, 2-9, 2-11, 2-13, 4-8, 4-16, 5-9, 5-11, 5-13, 6-9, 6-11, 6-13, 8-16, 9-11, 9-13, and 11-13.

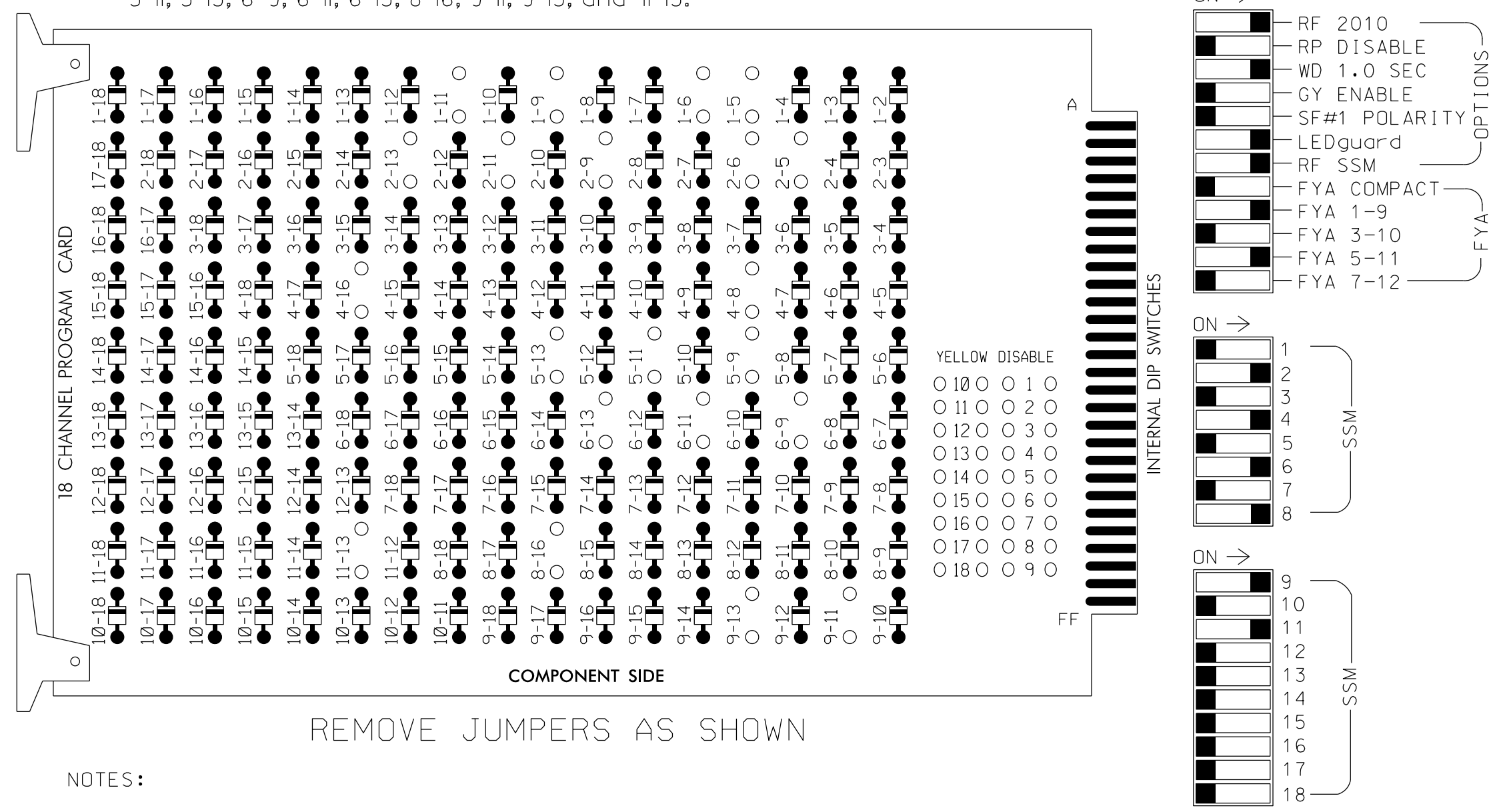

REMOVE JUMPERS AS SHOWN

NOTES:

- Card is provided with all diode jumpers in place. Removal of any jumper allows its channels to run concurrently.
- Ensure jumpers SEL2-SEL5 and SEL9 are present on the monitor board.
- Ensure that Red Enable is active at all times during normal operation.
- Integrate monitor with Ethernet network in cabinet.

NOTES

- To prevent "flash-conflict" problems, insert red flash program blocks for all unused vehicle load switches in the output file. The installer shall verify that signal heads flash in accordance with the Signal Plans.
- Program phases 4 and 8 for Dual Entry.
- Program controller to start up in phase 2 Walk and phase 6 Green.
- The cabinet and controller are part of the Burlington-Graham Signal System.

EQUIPMENT INFORMATION

CONTROLLER.....2070LX
 CABINET.....332 W/AUX
 SOFTWARE.....ECONOLITE ASC/3-2070
 CABINET MOUNT.....BASE
 OUTPUT FILE POSITIONS...18 WITH AUX. OUTPUT FILE LOAD SWITCHES USED.....S1,S2,S3,S5,S7,S8,S11,S12, AUX S1,AUX S4
 PHASES USED.....1,2,2PED,4,5,6,8,8PED
 OVERLAP "A".....*
 OVERLAP "B".....NOT USED
 OVERLAP "C".....*
 OVERLAP "D".....NOT USED

* See overlap programming detail on sheet 2

SIGNAL HEAD HOOK-UP CHART

LOAD SWITCH NO.	S1	S2	S3	S4	S5	S6	S7	S8	S9	S10	S11	S12	AUX S1	AUX S2	AUX S3	AUX S4	AUX S5	AUX S6
CMU CHANNEL NO.	1	2	13	3	4	14	5	6	15	7	8	16	9	10	17	11	12	18
PHASE	1	2	2 PED	3	4	4 PED	5	6	6 PED	7	8	8 PED	OLA	OLB	SPARE	OLC	OLD	SPARE
SIGNAL HEAD NO.	11	21,22	P21, P22	NU	41,42	NU	51	61,62	NU	NU	81,82	P81, P82	11	NU	NU	51	NU	NU
RED		128		101				134			107							
YELLOW	*	129		102			*	135			108							
GREEN		130		103				136			109							
RED ARROW													A121				A114	
YELLOW ARROW													A122				A115	
FLASHING YELLOW ARROW													A123				A116	
GREEN ARROW	127							133										
Hand icon				113									110					
Person icon				115									112					

NU = Not Used

* Denotes install load resistor. See load resistor installation detail this sheet.

★ See pictorial of head wiring in detail this sheet.

COUNTDOWN PEDESTRIAN SIGNAL OPERATION

Countdown Ped Signals are required to display timing only during Ped Clearance Interval. Consult Ped Signal Module user's manual for instructions on selecting this feature.

INPUT FILE POSITION LAYOUT

(front view)

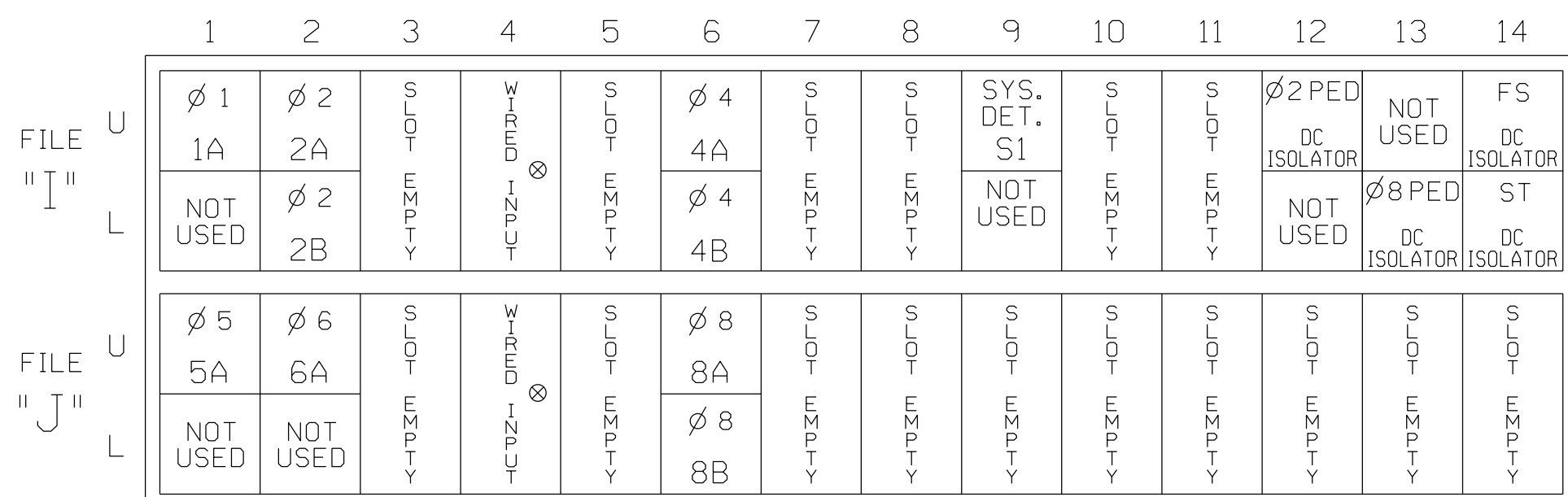

EX.: 1A, 2A, ETC. = LOOP NO.'S

FS = FLASH SENSE
 ST = STOP TIME

⊗ Wired input - Do not populate slot with detector card.

INPUT FILE CONNECTION & PROGRAMMING CHART

LOOP NO.	LOOP TERMINAL	INPUT FILE POS.	PIN NO.	DETECTOR NO.	NEMA PHASE	CALL	EXTEND TIME	DELAY TIME	ADDED INITIAL	DETECTOR TYPE
1A ¹	TB2-1,2	I1U	56	1★	1	YES		15		S
2A	TB2-5,6	J4U	48	26★	6	YES				S
2B	TB2-7,8	I2L	39	2	2	YES				S
4A	TB4-9,10	I6U	41	4	4	YES				S
4B	TB4-11,12	I6L	45	14	4	YES		10		S
* S1	TB6-9,10	I9U	60	11	SYS	NO				N
5A ²	TB3-1,2	J1U	55	5★	5	YES		15		S
6A	TB3-5,6	J2U	40	6	6	YES				S
8A	TB5-9,10	J6U	42	8	8	YES				S
8B	TB5-11,12	J6L	46	18	8	YES		10		S
PED PUSH BUTTONS										
P21,P22	TB8-4,6	I12U	67	PED 2	2	PED				
P81,P82	TB8-8,9	I13L	70	PED 8	8	PED				

NOTE:
 INSTALL DC ISOLATORS IN INPUT FILE SLOTS 112 AND 113.

- * System detector only. Remove any assigned vehicle phase.
- ¹Add jumper from I1-W to J4-W, on rear of input file.
- ²Add jumper from J1-W to I4-W, on rear of input file.
- ★ See vehicle detector setup programming detail for alternate phasing on sheet 3.

INPUT FILE POSITION LEGEND: J2L



FYA SIGNAL WIRING DETAIL

(wire signal heads as shown)

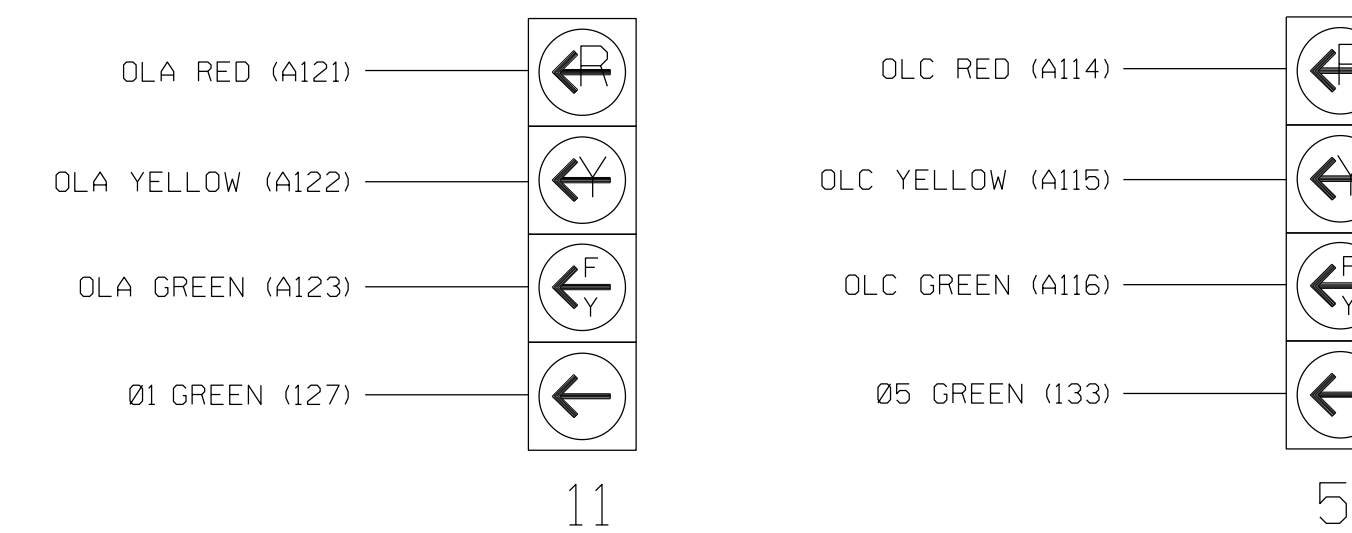

THIS ELECTRICAL DETAIL IS FOR THE SIGNAL DESIGN: 07-1718
 DESIGNED: DECEMBER 2017
 SEALED: 06-13-2018
 REVISED: N/A

LOAD RESISTOR INSTALLATION DETAIL

(install resistors as shown)

VALUE (ohms)	WATTAGE
1.5K - 1.9K	25W (min)
2.0K - 3.0K	10W (min)

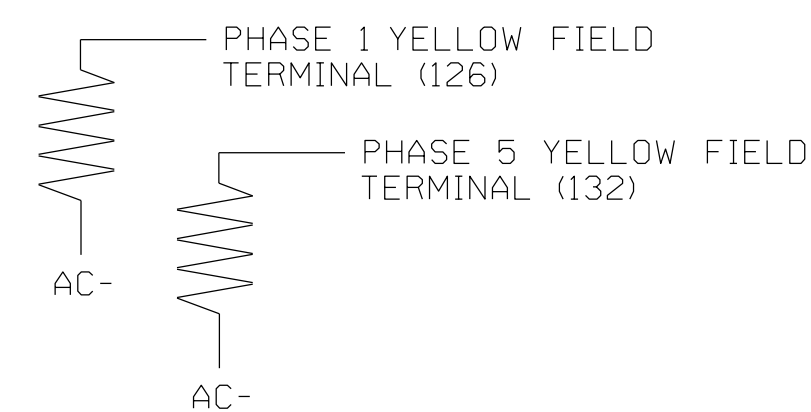

13-Jul-2018 10:19 R:\66015\W\off\ek\signals\des\gm\w\ir\ing\07-1718a.dgn Moon AT CAR-L\MOON-W

Electrical Detail Sheet 1 of 4

ELECTRICAL AND PROGRAMMING DETAILS FOR:

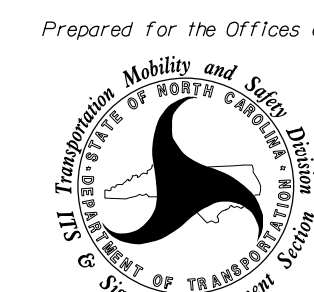

Edgewood Avenue at SR 1452 (Rockwood Avenue/N. O'Neal Street)
 Division 7 Alamance County Burlington
 PLAN DATE: December 2017 REVIEWED BY: AJ Davis
 PREPARED BY: DJ White REVIEWED BY: LM Moon

REVISIONS	INIT.	DATE

DOCUMENT NOT CONSIDERED FINAL UNLESS ALL SIGNATURES COMPLETED

SEAL NORTH CAROLINA PROFESSIONAL ENGINEER SEAL 022516 LISA M. MOON

DocuSigned by: Lisa M. Moon 6/13/2018
 SIG. INVENTORY NO. 07-1718

ECONOLITE ASC/3-2070 OVERLAP PROGRAMMING DETAIL

(program controller as shown)

1. From Main Menu select 2. CONTROLLER
2. From CONTROLLER Submenu select 2. VEHICLE OVERLAPS

OVERLAP A

Select TMG VEH OVLP [A] and 'PPLT FYA'

```

TMG VEH OVLP...[A] TYPE: ....PPLT FYA
PROTECTED LEFT TURN.... PHASE 1
OPPOSING THROUGH..... PHASE 2

FLASHING ARROW OUTPUT.....CH9 ISOLATE
DELAY START OF: FYA..0.0 CLEARANCE..0.0
ACTION PLAN SF BIT DISABLE..... 1
```

← NOTICE ACTION PLAN SF BIT "1"

Toggle Twice

OVERLAP C

Select TMG VEH OVLP [C] and 'PPLT FYA'

```

TMG VEH OVLP...[C] TYPE: ....PPLT FYA
PROTECTED LEFT TURN.... PHASE 5
OPPOSING THROUGH..... PHASE 6

FLASHING ARROW OUTPUT.....CH11 ISOLATE
DELAY START OF: FYA..0.0 CLEARANCE..0.0
ACTION PLAN SF BIT DISABLE..... 5
```



← NOTICE ACTION PLAN SF BIT "5"

END PROGRAMMING

THIS ELECTRICAL DETAIL IS FOR
THE SIGNAL DESIGN: 07-1718
DESIGNED: DECEMBER 2017
SEALED: 06-13-2018
REVISED: N/A

Electrical Detail Sheet 2 of 4

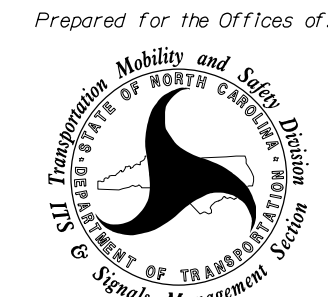
**DOCUMENT NOT CONSIDERED
FINAL UNLESS ALL
SIGNATURES COMPLETED**

<p>ELECTRICAL AND PROGRAMMING DETAILS FOR:</p> <p style="text-align: center;"><i>Prepared for the Offices of:</i></p> <div style="text-align: center;">  </div> <p style="text-align: center;">Plans Prepared By:</p> <div style="text-align: center;">  </div> <p style="text-align: center; font-size: small;">DRMP, Inc. 8000 Regency Parkway, Suite 175 Cary, NC 27519 NC License No. C-2213 (919) 650-1038</p>	<p>Edgewood Avenue at SR 1452 (Rockwood Avenue/N. O'Neal Street)</p> <p>Division 7 Alamance County Burlington</p> <table style="width: 100%; border-collapse: collapse;"> <tr> <td style="border: 1px solid black;">PLAN DATE: December 2017</td> <td style="border: 1px solid black;">REVIEWED BY: AJ Davis</td> </tr> <tr> <td style="border: 1px solid black;">PREPARED BY: DJ White</td> <td style="border: 1px solid black;">REVIEWED BY: LM Moon</td> </tr> </table> <table style="width: 100%; border-collapse: collapse;"> <thead> <tr> <th style="border: 1px solid black;">REVISIONS</th> <th style="border: 1px solid black;">INIT.</th> <th style="border: 1px solid black;">DATE</th> </tr> </thead> <tbody> <tr> <td style="border: 1px solid black;"> </td> <td style="border: 1px solid black;"> </td> <td style="border: 1px solid black;"> </td> </tr> <tr> <td style="border: 1px solid black;"> </td> <td style="border: 1px solid black;"> </td> <td style="border: 1px solid black;"> </td> </tr> </tbody> </table>	PLAN DATE: December 2017	REVIEWED BY: AJ Davis	PREPARED BY: DJ White	REVIEWED BY: LM Moon	REVISIONS	INIT.	DATE							<p style="text-align: center;">SEAL</p> <div style="text-align: center;">  </div> <p style="text-align: center; font-size: small;">DocuSigned by: <i>Lisa M. Moon</i> 6/13/2018 SIC688083D0421 DATE SIG. INVENTORY NO. 07-1718</p>
PLAN DATE: December 2017	REVIEWED BY: AJ Davis														
PREPARED BY: DJ White	REVIEWED BY: LM Moon														
REVISIONS	INIT.	DATE													

13-JUN-2018 17:57
 R:\66015\1718\1718\esign\gnw\ir\ing\07-1718e.dgn
 r:\lawton AT CAR-RLAWTON-W7

ECONOLITE ASC/3-2070 VEHICLE DETECTOR SETUP PROGRAMMING DETAIL FOR ALTERNATE PHASING (FOR LOOPS 1A AND 5A)

(program controller as shown)

IMPORTANT!

Program detectors per the input file connection and programming chart shown on sheet 1 before proceeding.

- From Main Menu select **8. UTILITIES**
- From UTILITIES Submenu select **1. COPY/CLEAR**
- Copy from DETECTOR PLAN "1" to DETECTOR PLAN "2".

```

COPY / CLEAR UTILITY
FROM          TO
PHASE TIMING... > PHASE TIMING...
TIMING PLAN... > TIMING PLAN...
PH DET OPT PLAN. > PH DET OPT PLAN.
DETECTOR PLAN... 1 > DETECTOR PLAN... 2
TOGGLE TO SELECT A "FROM" AND A "TO"
THEN PRESS ENTER
    
```

- From Main Menu select **6. DETECTORS**
- From DETECTOR Submenu select **2. VEHICLE DETECTOR SETUP**
- Place cursor in VEH DET PLAN [] position and enter "2".

- Place cursor in VEH DETECTOR [] position and enter "1".
- Set delay time to "0".

```

VEH DETECTOR [ 1] VEH DET PLAN [ 2]
TYPE: S-STANDARD
TS2 DETECTOR..... ECP1 LOG..... NO
DET PH - 1 2 3 4 5 6 7 8 9 0 1 2 3 4 5 6
1 1 .....
EXTEND TIME... 0.0 DELAY TIME... 0.0
USE ADDED INITIAL . CROSS SWITCH PH.. 0
LOCK IN..... NONE NTCIP VOL . OR OCC .
PMT QUEUE DELAY. NO
    
```

← NOTICE VEH DET PLAN 2

← ENSURE DELAY IS SET TO "0"

- Place cursor in VEH DETECTOR [] position and enter "26".
- Set assigned phase to "0".

```

VEH DETECTOR [ 26] VEH DET PLAN [ 2]
TYPE: S-STANDARD
TS2 DETECTOR..... ECP1 LOG..... NO
DET PH - 1 2 3 4 5 6 7 8 9 0 1 2 3 4 5 6
26 0 .....
EXTEND TIME... 0.0 DELAY TIME... 0.0
USE ADDED INITIAL . CROSS SWITCH PH.. 0
LOCK IN..... NONE NTCIP VOL . OR OCC .
PMT QUEUE DELAY. NO
    
```

← NOTICE VEH DET PLAN 2

ENSURE PHASE IS SET TO "0" →

- Place cursor in VEH DETECTOR [] position and enter "5".
- Set delay time to "0".

```

VEH DETECTOR [ 5] VEH DET PLAN [ 2]
TYPE: S-STANDARD
TS2 DETECTOR..... ECP1 LOG..... NO
DET PH - 1 2 3 4 5 6 7 8 9 0 1 2 3 4 5 6
5 5 .....
EXTEND TIME... 0.0 DELAY TIME... 0.0
USE ADDED INITIAL . CROSS SWITCH PH.. 0
LOCK IN..... NONE NTCIP VOL . OR OCC .
PMT QUEUE DELAY. NO
    
```

← NOTICE VEH DET PLAN 2

← ENSURE DELAY IS SET TO "0"

- Place cursor in VEH DETECTOR [] position and enter "22".
- Set assigned phase to "0".

```

VEH DETECTOR [ 22] VEH DET PLAN [ 2]
TYPE: S-STANDARD
TS2 DETECTOR..... ECP1 LOG..... NO
DET PH - 1 2 3 4 5 6 7 8 9 0 1 2 3 4 5 6
22 0 .....
EXTEND TIME... 0.0 DELAY TIME... 0.0
USE ADDED INITIAL . CROSS SWITCH PH.. 0
LOCK IN..... NONE NTCIP VOL . OR OCC .
PMT QUEUE DELAY. NO
    
```

← NOTICE VEH DET PLAN 2

ENSURE PHASE IS SET TO "0" →

END PROGRAMMING

THIS ELECTRICAL DETAIL IS FOR THE SIGNAL DESIGN: 07-1718
DESIGNED: DECEMBER 2017
SEALED: 06-13-2018
REVISED: N/A

Electrical Detail Sheet 3 of 4



ELECTRICAL AND PROGRAMMING DETAILS FOR:

Prepared for the Offices of:

750 N. Greenfield Pkwy, Garner, NC 27529

Edgewood Avenue
at
SR 1452
(Rockwood Avenue/N. O'Neal Street)

Division 7 Alamance County Burlington

PLAN DATE: December 2017	REVIEWED BY: AJ Davis
PREPARED BY: DJ White	REVIEWED BY: LM Moon
REVISIONS	INIT. DATE

DOCUMENT NOT CONSIDERED FINAL UNLESS ALL SIGNATURES COMPLETED

SEAL

DocuSigned by:
Lisa M. Moon 6/13/2018

SIG. INVENTORY NO. 07-1718

ALTERNATE PHASING ACTIVATION DETAIL

TO RUN ALT. PHASING DURING FREE RUN - PROGRAM CHANGES (SHOWN BELOW) IN A TIME BASED ACTION PLAN. SCHEDULE A DAY PLAN THAT INCLUDES THE ACTION PLAN PROGRAMMED TO SELECT VEH DET PLAN 2 AND ENABLE SF BITS 1 AND 5.

TO RUN ALT. PHASING DURING COORDINATION - SELECT THE TIME BASED ACTION PLAN THAT IS PROGRAMMED TO SELECT VEH DET PLAN 2 AND ENABLE SF BITS 1 AND 5.

PHASING	VEH DET PLAN	SF BITS ENABLED
ACTIONS REQUIRED TO RUN <u>DEFAULT PHASING</u>	1	NONE
ACTIONS REQUIRED TO RUN <u>ALTERNATE PHASING</u>	2	1,5

IMPORTANT: IF ALT. PHASING IS USED DURING FREE RUN AND COORDINATION, DO NOT OPERATE TIME OF DAY EVENTS CONCURRENTLY WITH COORDINATION PLAN EVENTS IN THE EVENT SCHEDULER. (EX. FREE RUN EVENT SHOULD END BEFORE COORDINATION PLAN EVENT STARTS AND VICE-VERSA).

ALTERNATE PHASING CHANGE SUMMARY

THE FOLLOWING IS A SUMMARY OF WHAT TAKES PLACE WHEN SF BITS 1 AND 5 AND VEH DET PLAN 2 ACTIVATE TO CALL THE "ALTERNATE PHASING":

- SF BITS 1,5: Modifies overlap parent phases for heads 11 and 51 to run protected turns only.

- VEH DET PLAN 2: Disables phase 6 call on loop 1A and reduces delay time for phase 1 call on loop 1A to 0 seconds.

Disables phase 2 call on loop 5A and reduces delay time for phase 5 call on loop 5A to 0 seconds.

ECONOLITE ASC/3-2070 ACTION PLAN PROGRAMMING DETAIL

1. From Main Menu select 5. TIME BASE
2. From TIME BASE Submenu select 2. ACTION PLAN

```

ACTION PLAN...[ 1]
PATTERN.....AUTO  SYS OVERRIDE.... NO
TIMING PLAN..... 0  SEQUENCE..... 0
VEH DETECTOR PLAN.. 2  DET LOG.....NONE
FLASH..... --  RED REST..... NO
VEH DET DIAG PLN... 0  PED DET DIAG PLN..0
DIMMING ENABLE.. NO  PRIORITY RETURN. NO
PED PR RETURN.. NO  QUEUE DELAY..... NO
PMT COND DELAY  NO
  PHASE  1  2  3  4  5  6  7  8  9  0  1  2  3  4  5  6
PED RCL  .  .  .  .  .  .  .  .  .  .  .  .  .  .  .  .
WALK 2   .  .  .  .  .  .  .  .  .  .  .  .  .  .  .  .
VEX 2    .  .  .  .  .  .  .  .  .  .  .  .  .  .  .  .
VEH RCL  .  .  .  .  .  .  .  .  .  .  .  .  .  .  .  .
MAX RCL  .  .  .  .  .  .  .  .  .  .  .  .  .  .  .  .
MAX 2    .  .  .  .  .  .  .  .  .  .  .  .  .  .  .  .
  PHASE  1  2  3  4  5  6  7  8  9  0  1  2  3  4  5  6
MAX 3    .  .  .  .  .  .  .  .  .  .  .  .  .  .  .  .
CS INH   .  .  .  .  .  .  .  .  .  .  .  .  .  .  .  .
OMIT     .  .  .  .  .  .  .  .  .  .  .  .  .  .  .  .
SPC FCT  X  .  .  .  X  .  .  .  (1-8)
AUX FCT  .  .  .  (1-3)
          1  2  3  4  5  6  7  8  9  0  1  2  3  4  5
LP 1-15  .  .  .  .  .  .  .  .  .  .  .  .  .  .  .  .
LP 16-30 .  .  .  .  .  .  .  .  .  .  .  .  .  .  .  .
LP 31-45 .  .  .  .  .  .  .  .  .  .  .  .  .  .  .  .
LP 46-60 .  .  .  .  .  .  .  .  .  .  .  .  .  .  .  .
LP 61-75 .  .  .  .  .  .  .  .  .  .  .  .  .  .  .  .
LP 76-90 .  .  .  .  .  .  .  .  .  .  .  .  .  .  .  .
LP 91-100 .  .  .  .  .  .  .  .  .  .  .  .  .  .  .  .
    
```

THIS ELECTRICAL DETAIL IS FOR THE SIGNAL DESIGN: 07-1718
DESIGNED: DECEMBER 2017
SEALED: 06-13-2018
REVISED: N/A

Electrical Detail Sheet 4 of 4



ELECTRICAL AND PROGRAMMING DETAILS FOR:

Prepared for the Offices of:

750 N. Greenfield Pkwy, Garner, NC 27529

Edgewood Avenue
at
SR 1452
(Rockwood Avenue/N. O'Neal Street)
Division 7 Alamance County Burlington

PLAN DATE: December 2017	REVIEWED BY: AJ Davis
PREPARED BY: DJ White	REVIEWED BY: LM Moon
REVISIONS	INIT. DATE

DOCUMENT NOT CONSIDERED FINAL UNLESS ALL SIGNATURES COMPLETED

SEAL

DocuSigned by:
Lisa M. Moon 6/13/2018
DATE
SIG. INVENTORY NO. 07-1718

PHASING DIAGRAM

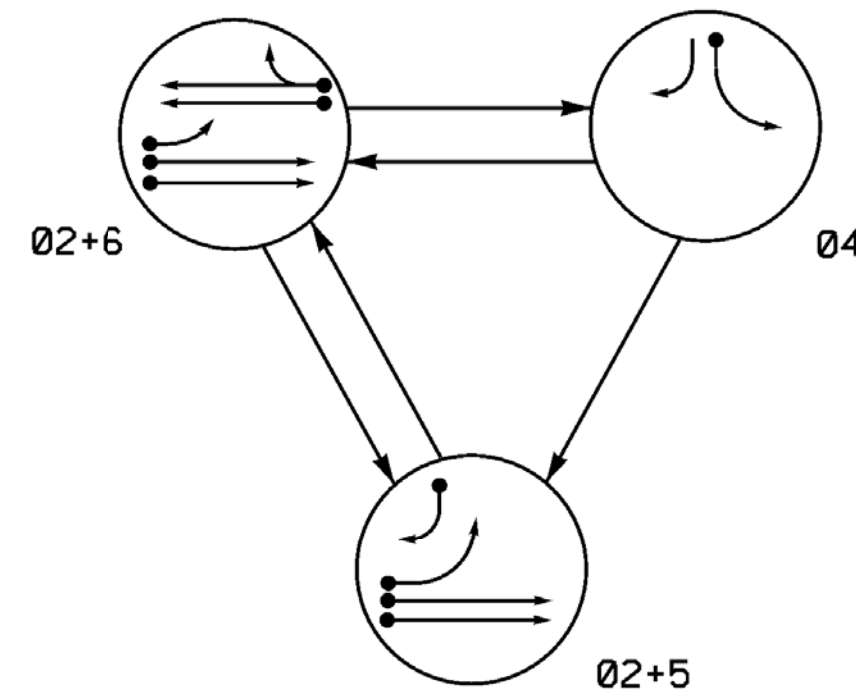

SIGNAL FACE	PHASE			
	02+5	02+6	04	FLASH
21,22,23	G	G	R	Y
41	R	R	G	R
42	R	R	G	R
51	-	-	-	-
61,62	R	G	R	Y

ASC/3 DETECTOR INSTALLATION CHART												
DETECTOR					PROGRAMMING							
LOOP	SIZE (FT)	DISTANCE FROM STOPBAR (FT)	TURNS	NEW LOOP	PHASE	CALLING	EXTEND TIME	DELAY TIME	USE ADDED INITIAL	TYPE	SYSTEM LOOP	NEW CARD
2A,2B	6x6	360	EXIST.	-	2	Yes	-	-	X	N	-	X
4A	6x60	0	2-4-2	-	4	Yes	-	3	-	S	-	X
5A	6x60	0	2-4-2	-	5	Yes	-	15	-	S	-	X
5B	6x60	0	2-4-2	-	5	Yes	-	15	-	S	-	X
6A,6B	6x6	360	EXIST.	-	6	Yes	-	-	X	N	-	X

3 Phase Fully Actuated (Burlington-Graham Signal System)

NOTES

- Refer to "Roadway Standard Drawings NCDOT" dated January 2018 and "Standard Specifications for Roads and Structures" dated January 2018.
- Do not program signal for late night flashing operation unless otherwise directed by the Engineer.
- Phase 5 may be lagged.
- Reposition existing signal head numbered 22.
- Set all detector units to presence mode.
- In the event of loop replacement, refer to the current ITS and Signals Design Manual and submit a Plan of Record to the Signal Design Section.
- Locate new cabinet so as not to obstruct sight distance of vehicles turning right on red.
- Pavement markings are existing.
- Maximum times shown in timing chart are for free-run operation only. Coordinated signal system timing values supersede these values.

SIGNAL FACE I.D.

All Heads L.E.D.

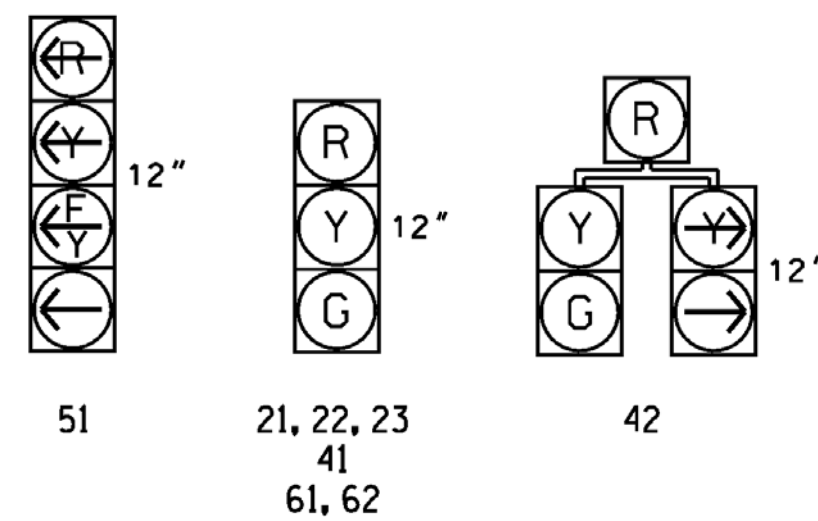

PHASING DIAGRAM DETECTION LEGEND

- ←● DETECTED MOVEMENT
- ← UNDETECTED MOVEMENT (OVERLAP)
- UN SIGNALIZED MOVEMENT
- ←--- PEDESTRIAN MOVEMENT

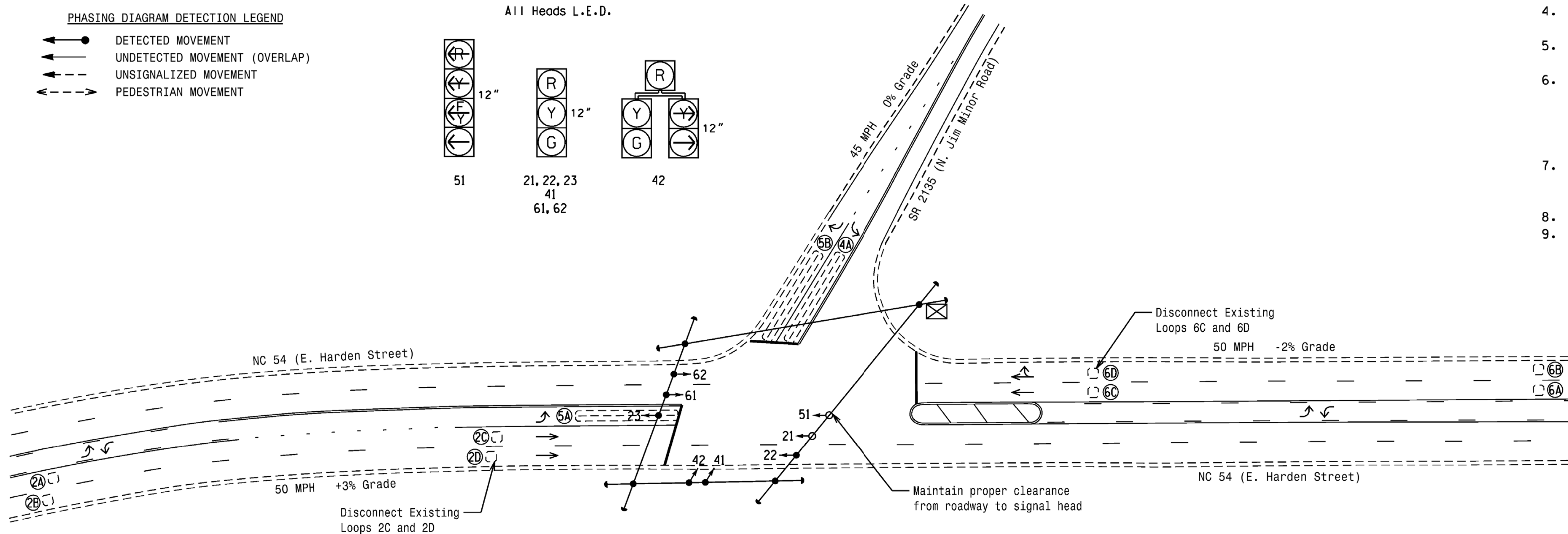

LEGEND

- | PROPOSED | EXISTING |
|--|----------|
| ○→ Traffic Signal Head | ●→ N/A |
| ○→ Modified Signal Head | ○→ N/A |
| ⊥ Sign | ⊥ N/A |
| ⊥ Pedestrian Signal Head With Push Button & Sign | ⊥ N/A |
| ⊥ Signal Pole with Guy | ⊥ N/A |
| ⊥ Signal Pole with Sidewalk Guy | ⊥ N/A |
| □ Inductive Loop Detector | □ N/A |
| ⊠ Controller & Cabinet | ⊠ N/A |
| □ Junction Box | □ N/A |
| --- 2-in Underground Conduit | --- N/A |
| N/A Right of Way | N/A |
| → Directional Arrow | → |

FEATURE	PHASE			
	2	4	5	6
Min Green *	14	7	7	14
Walk *	0	0	0	0
Ped Clear	0	0	0	0
Veh. Extension *	6.0	2.0	2.0	6.0
Max I *	90	25	15	90
Yellow	5.0	3.0	3.0	5.0
Red Clear	1.6	1.9	2.6	1.6
Actuations B4 Add *	0	-	-	0
Seconds / Actuation *	1.5	-	-	1.5
Max Initial *	40	-	-	40
Time Before Reduction *	15	-	-	15
Time To Reduce *	30	-	-	30
Minimum Gap	3.0	-	-	3.0
Locking Detector	X	-	-	X
Recall Position	VEH. RECALL	-	-	VEH. RECALL
Dual Entry	-	-	-	-
Simultaneous Gap	X	X	X	X

* These values may be field adjusted. Do not adjust Min Green and Extension times for phases 2 and 6 lower than what is shown. Min Green for all other phases should not be lower than 4 seconds.

Mattern & Craig
ENGINEERS • SURVEYORS

12 BROAD STREET
ASHEVILLE, NORTH CAROLINA 28801
(828) 254-2201
FAX (828) 254-4562
NC LIC. NO. C-1154

Signal Upgrade

Prepared for the Offices of:
TRANSPORTATION MOBILITY AND SAFETY DIVISION
DEPARTMENT OF TRANSPORTATION
Signal Design Section
750 N. Greenfield Pkwy, Garner, NC 27529

DOCUMENT NOT CONSIDERED FINAL UNLESS ALL SIGNATURES COMPLETED

NC 54 (E. Harden Street) at SR 2135 (N. Jim Minor Road)

Division 7 Alamance County Graham

PLAN DATE: November 2017 REVIEWED BY: JB Voso

PREPARED BY: SE Wilson REVIEWED BY:

REVISIONS

INIT. DATE

SCALE 0 40
1"=40'

SEAL
NORTH CAROLINA PROFESSIONAL ENGINEER
JAMES B. VOSO
022599
6/13/2018

SIG. INVENTORY NO. 07-1719

EDI MODEL 2018EClip-NC CONFLICT MONITOR PROGRAMMING DETAIL
(remove jumpers and set switches as shown)

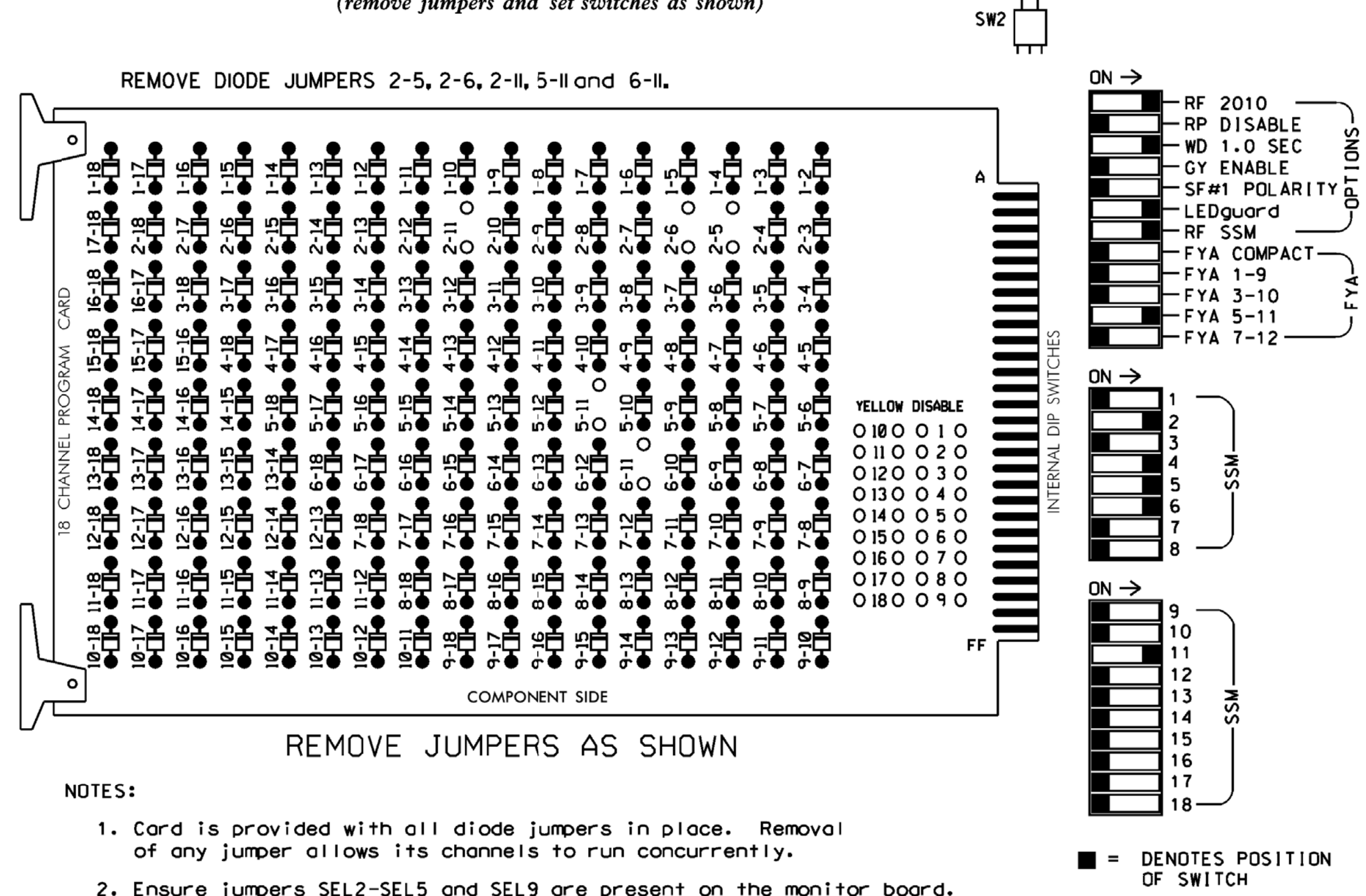

- NOTES:**
- Card is provided with all diode jumpers in place. Removal of any jumper allows its channels to run concurrently.
 - Ensure jumpers SEL2-SEL5 and SEL9 are present on the monitor board.
 - Ensure that Red Enable is active at all times during normal operation.
 - Integrate monitor with Ethernet network in cabinet.

NOTES

- To prevent "flash-conflict" problems, insert red flash program blocks for all unused vehicle load switches in the output file. The installer shall verify that signal heads flash in accordance with the Signal Plans.
- Program controller to start up in phase 2 Green and 6 Green.
- The cabinet and controller are part of the Burlington-Graham Signal System.

EQUIPMENT INFORMATION

CONTROLLER.....2070LX
 CABINET.....332 W/AUX
 SOFTWARE.....ECONOLITE ASC/3-2070
 CABINET MOUNT.....BASE
 OUTPUT FILE POSITIONS...18 WITH AUX. OUTPUT FILE
 LOAD SWITCHES USED.....S2,S5,S7,S8,AUX S4
 PHASES USED.....2,4,5,6
 OVERLAP "A".....NOT USED
 OVERLAP "B".....NOT USED
 OVERLAP "C".....*
 OVERLAP "D".....NOT USED

* See overlap programming detail on sheet 2

SIGNAL HEAD HOOK-UP CHART

LOAD SWITCH NO.	S1	S2	S3	S4	S5	S6	S7	S8	S9	S10	S11	S12	AUX S1	AUX S2	AUX S3	AUX S4	AUX S5	AUX S6	
CMU CHANNEL NO.	1	2	13	3	4	14	5	6	15	7	8	16	9	10	17	11	12	18	
PHASE	1	2	2 PED	3	4	4 PED	5	6	6 PED	7	8	8 PED	OLA	OLB	SPARE	OLC	OLD	SPARE	
SIGNAL HEAD NO.	NU	21,22,23	NU	NU	41,42	NU	42	51*	61,62	NU	NU	NU	NU	NU	NU	51*	NU	NU	
RED		128			101		*		134										
YELLOW					102				135										
GREEN		130			103				136										
RED ARROW																		A114	
YELLOW ARROW								132											A115
FLASHING YELLOW ARROW																			A116
GREEN ARROW								133	133										

NU = Not Used
 * Denotes install load resistor. See load resistor installation detail this sheet.
 * See pictorial of head wiring in detail this sheet.

INPUT FILE POSITION LAYOUT
(front view)

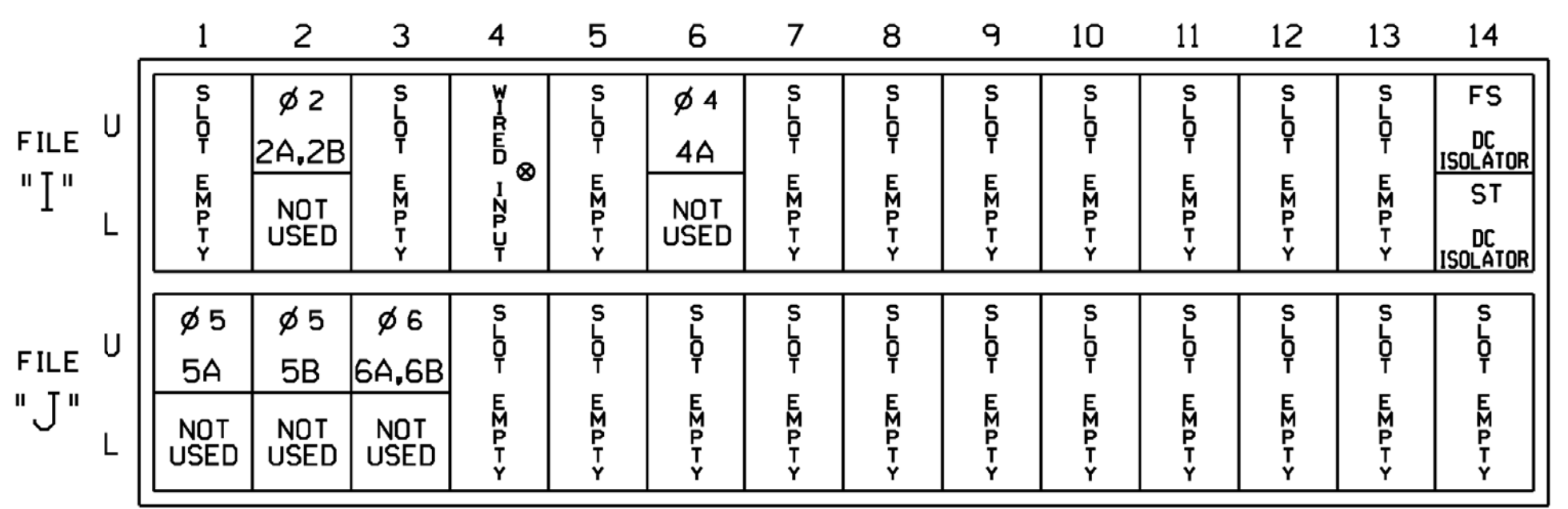

EX.: 1A, 2A, ETC. = LOOP NO.'S
 FS = FLASH SENSE
 ST = STOP TIME
 * Wired Input - Do not populate slot with detector card

INPUT FILE CONNECTION & PROGRAMMING CHART

LOOP NO.	LOOP TERMINAL	INPUT FILE POS.	PIN NO.	DETECTOR NO.	NEMA PHASE	CALL	EXTEND TIME	DELAY TIME	ADDED INITIAL	DETECTOR TYPE
2A,2B	TB2-5,6	I2U	39	2	2	YES			X	N
4A	TB4-9,10	I6U	41	4	4	YES		3		S
5A ¹	TB3-1,2	J1U	55	5	5	YES		15		S
		I4U	47	22	2	YES		3		G
5B	TB3-5,6	J2U	40	6	5	YES		15		S
6A,6B	TB3-9,10	J3U	64	36	6	YES			X	N

¹Add jumper from J1-W to I4-W, on rear of input file.

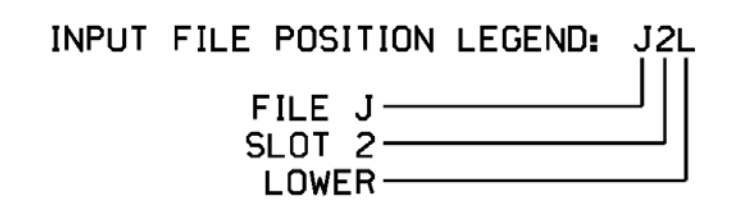

FYA SIGNAL WIRING DETAIL
(wire signal head as shown)

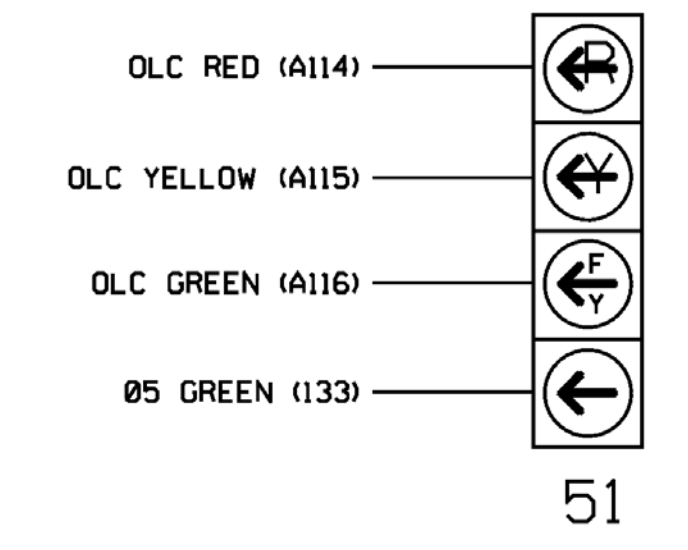

LOAD RESISTOR INSTALLATION DETAIL
(install resistor as shown)

VALUE (ohms)	WATTAGE
1.5K - 1.9K	25W (min)
2.0K - 3.0K	10W (min)

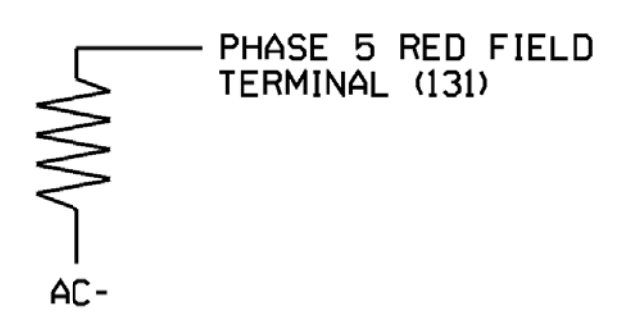

12 BROAD STREET
 ASHEVILLE, NORTH CAROLINA 28801
 (828) 254-2201
 FAX (828) 254-4562
 NC LIC. NO. C-1154

Electrical Detail - Sheet 1 of 2

DOCUMENT NOT CONSIDERED FINAL UNLESS ALL SIGNATURES COMPLETED

Electrical and Programming Details For: NC 54 (E. Harden Street) at SR 2135 (N. Jim Minor Road)

Division 7 Alamance County Graham

Prepared In the Offices of: JAMES B. VOSS, PE, License No. 022599

Prepared By: SE Wilson
 Reviewed By: JB Vosso

Plan Date: November 2017
 Design Date: November 2017
 Sealed: 6/13/2018
 Revised: NA

750 N. Greenfield Pkwy, Corner, NC 27529

Signature: James Vosso
 Date: 6/13/2018
 Sig. Inventory No.: 07-1719

*****SYTIME*****
 *****D*****
 *****USER*****

PHASING DIAGRAM

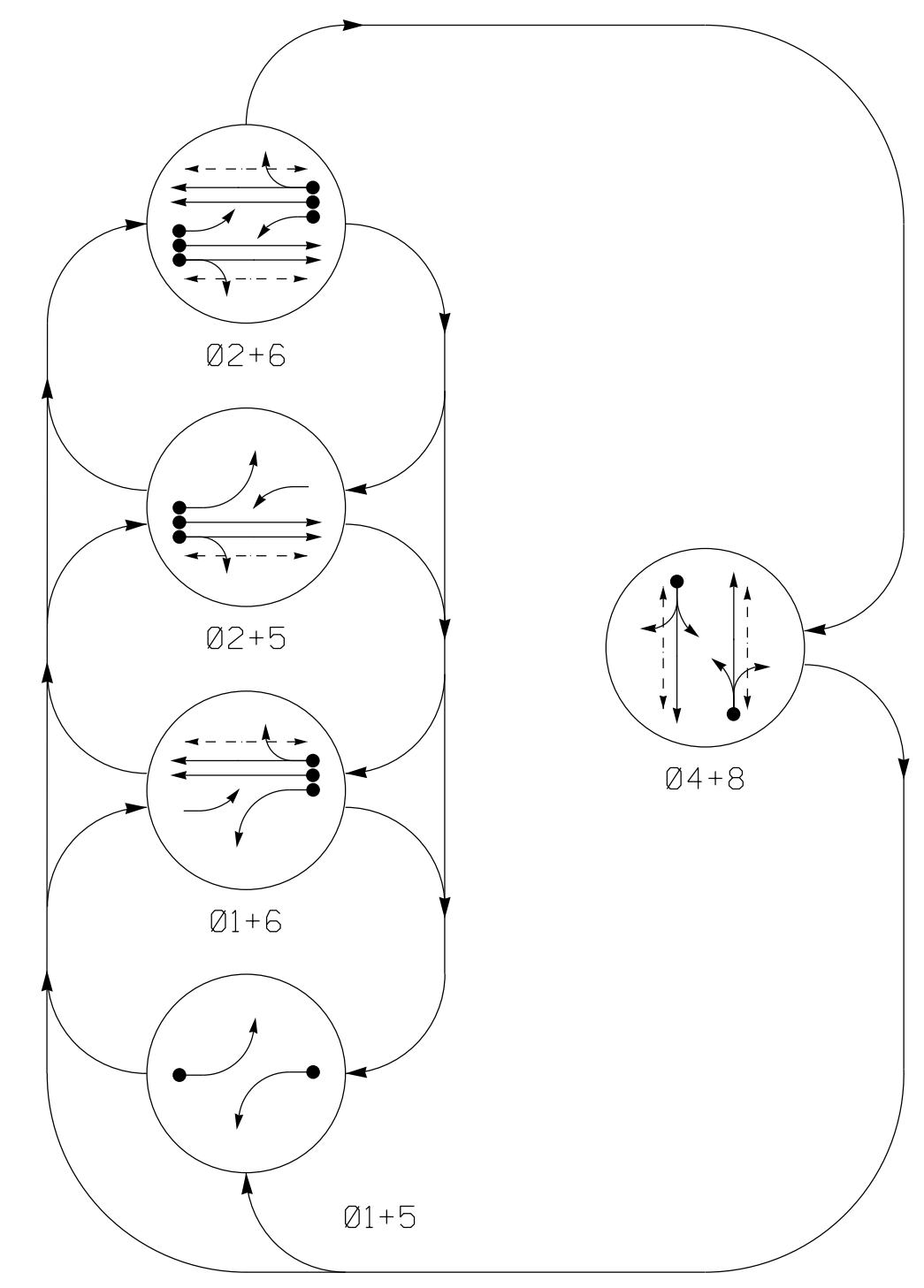

PHASING DIAGRAM DETECTION LEGEND

- DETECTED MOVEMENT
- UNDETECTED MOVEMENT (OVERLAP)
- ⋯ UNSIGNALIZED MOVEMENT
- ⋯ PEDESTRIAN MOVEMENT

TABLE OF OPERATION

SIGNAL FACE	PHASE					
	01+5	01+6	02+5	02+6	04+8	PEDESTRIAN
11	←	←	←	←	←	↕
21,22	R	R	G	G	R	Y
41,42	R	R	R	R	G	R
51	←	←	←	←	←	↕
61,62	R	G	R	G	R	Y
81,82	R	R	R	R	G	R
P21,P22	DW	DW	W	W	DW	DRK
P41,P42	DW	DW	DW	DW	W	DRK
P61,P62	DW	W	DW	W	DW	DRK
P81,P82	DW	DW	DW	DW	W	DRK

ASC/3 DETECTOR INSTALLATION CHART

LOOP	SIZE (FT)	DISTANCE FROM STOPBAR (FT)	TURNS	NEW LOOP	PROGRAMMING							
					PHASE	CALLING	EXTEND TIME	DELAY TIME	USE ADDED INITIAL	TYPE	SYSTEM LOOP	NEW CARD
1A	6X40	+10	2-4-2	-	1	Yes	-	15	-	S	-	X
2A	6X6	70	EXIST	-	2	Yes	-	-	-	S	-	X
2B	6X6	70	EXIST	-	2	Yes	-	-	-	S	-	X
4A	6X50	+10	2-4-2	-	4	Yes	-	5	-	S	-	X
5A	6X40	+10	2-4-2	-	5	Yes	-	15	-	S	-	X
6A	6X6	70	EXIST	-	6	Yes	-	-	-	S	-	X
6B	6X6	70	EXIST	-	6	Yes	-	-	-	S	-	X
8A	6X50	+10	2-4-2	-	8	Yes	-	5	-	S	-	X
S1	6X6	+95	3	X	-	No	-	-	-	N	X	X
S2	6X6	+95	3	X	-	No	-	-	-	N	X	X
S3	6X6	+95	3	X	-	No	-	-	-	N	X	X

5 Phase Fully Actuated (Burlington-Graham Signal System)

NOTES

- Refer to "Roadway Standard Drawings NCDOT" dated January 2018 and "Standard Specifications for Roads and Structures" dated January 2018.
- Do not program signal for late night flashing operation unless otherwise directed by Engineer.
- Phase 1 and/or phase 5 may be lagged.
- Reposition existing signal heads numbered 22 and 62.
- Set all detector units to presence mode.
- Locate new cabinet so as not to obstruct sight distance of vehicles turning right on red.
- Omit "WALK" and flashing "DON'T WALK" with no pedestrian calls.
- Program pedestrian heads to countdown the flashing "Don't Walk" time only.
- Pavement markings are existing.
- Maximum times shown in timing chart are for free-run operation only. Coordinated signal system timing values supersede these values.

SIGNAL FACE I.D.

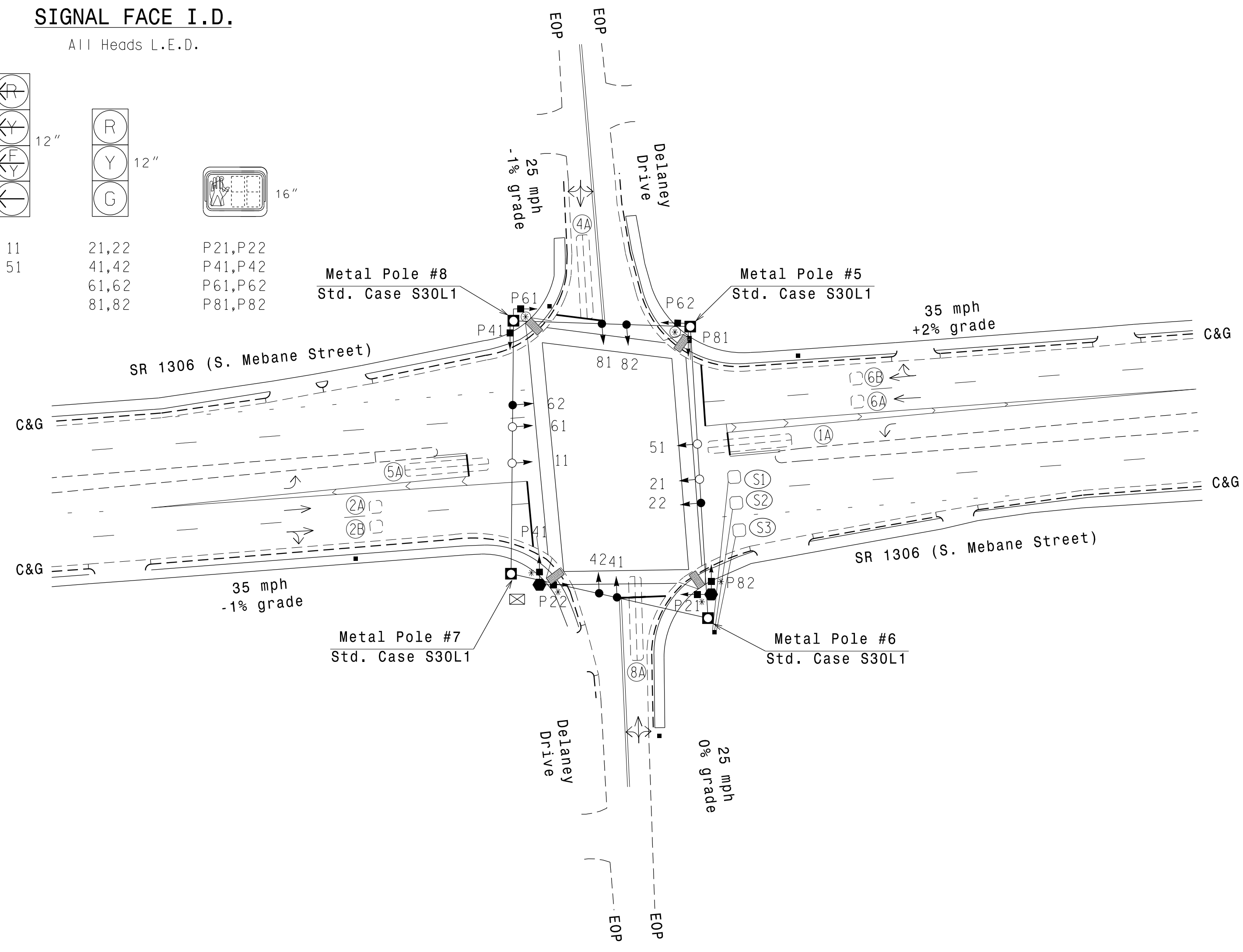
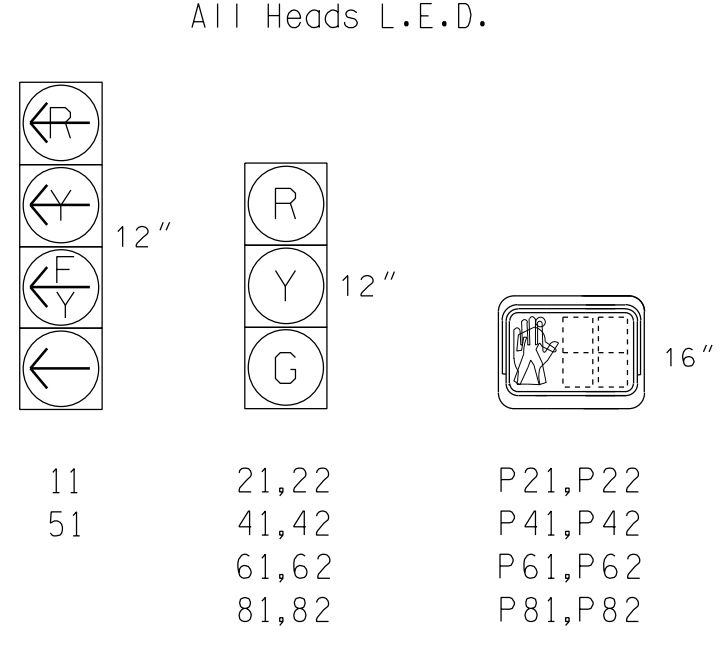

ASC/3 TIMING CHART

FEATURE	PHASE					
	1	2	4	5	6	8
Min Green *	7	10	7	7	10	7
Walk *	0	4	4	0	4	4
Ped Clear	0	14	29	0	17	28
Veh. Extension *	2.0	5.0	3.0	2.0	5.0	3.0
Max 1 *	20	45	30	20	45	30
Yellow	3.0	3.9	3.2	3.0	3.9	3.2
Red Clear	2.9	2.2	3.2	3.1	2.2	3.2
Actuations B4 Add *	-	-	-	-	-	-
Seconds / Actuation *	-	-	-	-	-	-
Max Initial *	-	-	-	-	-	-
Time Before Reduction *	-	-	-	-	-	-
Time To Reduce *	-	-	-	-	-	-
Minimum Gap	-	-	-	-	-	-
Locking Detector	-	X	-	-	X	-
Recall Position	-	VEH. RECALL	-	-	VEH. RECALL	-
Dual Entry	-	-	X	-	-	X
Simultaneous Gap	X	X	X	X	X	X

* These values may be field adjusted. Do not adjust Min Green and Extension times for phases 2 and 6 lower than what is shown. Min Green for all other phases should not be lower than 4 seconds.

LEGEND

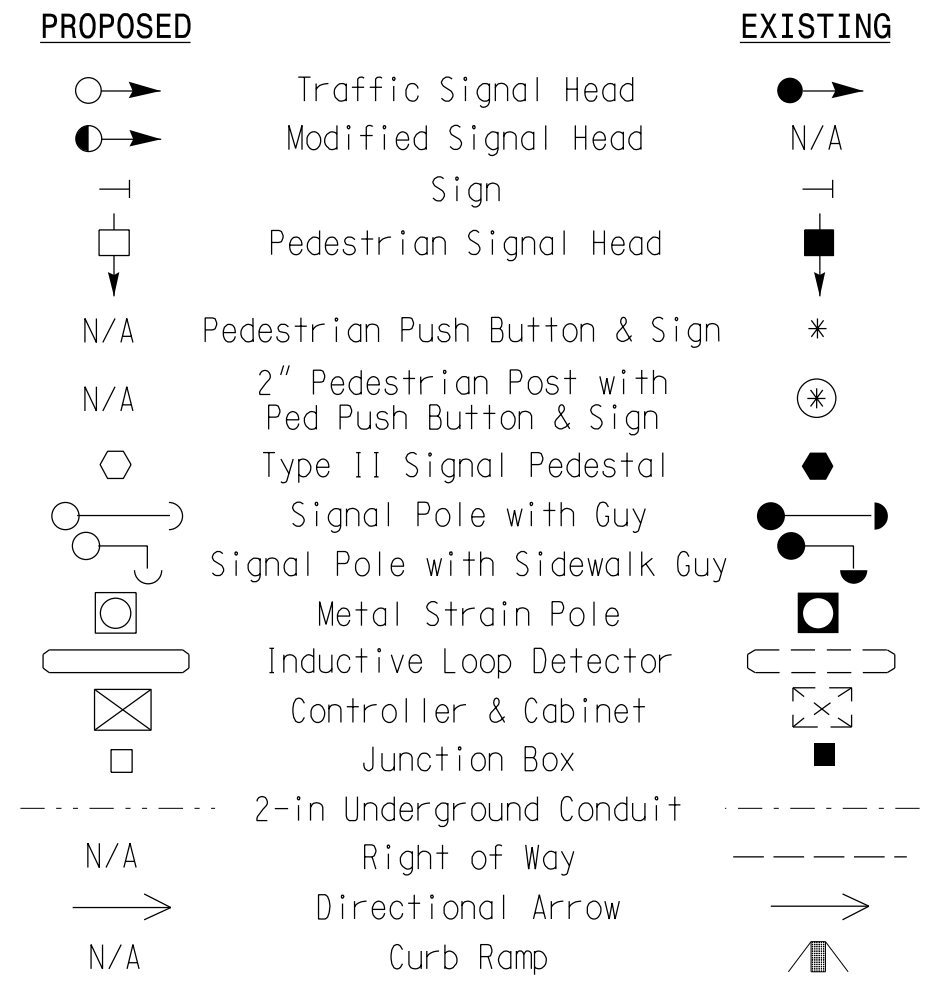

Signal Upgrade

750 N. Greenfield Pkwy, Garner, NC 27529

SR 1306 (S. Mebane Street) at Delaney Drive

Division 7 Alamance County Burlington

PLAN DATE: February 2018 REVIEWED BY: AM Encarnacion

PREPARED BY: NA Ptak REVIEWED BY: PL Alexander

SEAL

NORTH CAROLINA PROFESSIONAL ENGINEER

PAUL L. ALEXANDER

6/7/2018

DATE

SIG. INVENTORY NO. 07-1731

ATKINS 1616 EAST MILLBROOK ROAD, SUITE 160 RALEIGH, NORTH CAROLINA 27609 (919) 876-6888 NCBES #F-0326

07-JUN-2018 11:15 U:\Projects\Traffic\05-11-Signals\Des\Task 05-11-Signals\Task 05-11-Signals.dgn ALEX3361 AT LUS340649

EDI MODEL 2018ECLIP-NC CONFLICT MONITOR PROGRAMMING DETAIL

(remove jumpers and set switches as shown)

REMOVE DIODE JUMPERS J-5, J-6, J-9, J-11, J-15, J-2-5, J-2-6, J-2-9, J-2-11, J-2-13, J-2-15, J-4-8, J-4-14, J-4-16, J-5-9, J-5-11, J-5-13, J-6-9, J-6-11, J-6-13, J-6-15, J-8-14, J-8-16, J-9-11, J-9-13, J-9-15, J-11-13, J-11-15, J-13-15, and J-14-16.

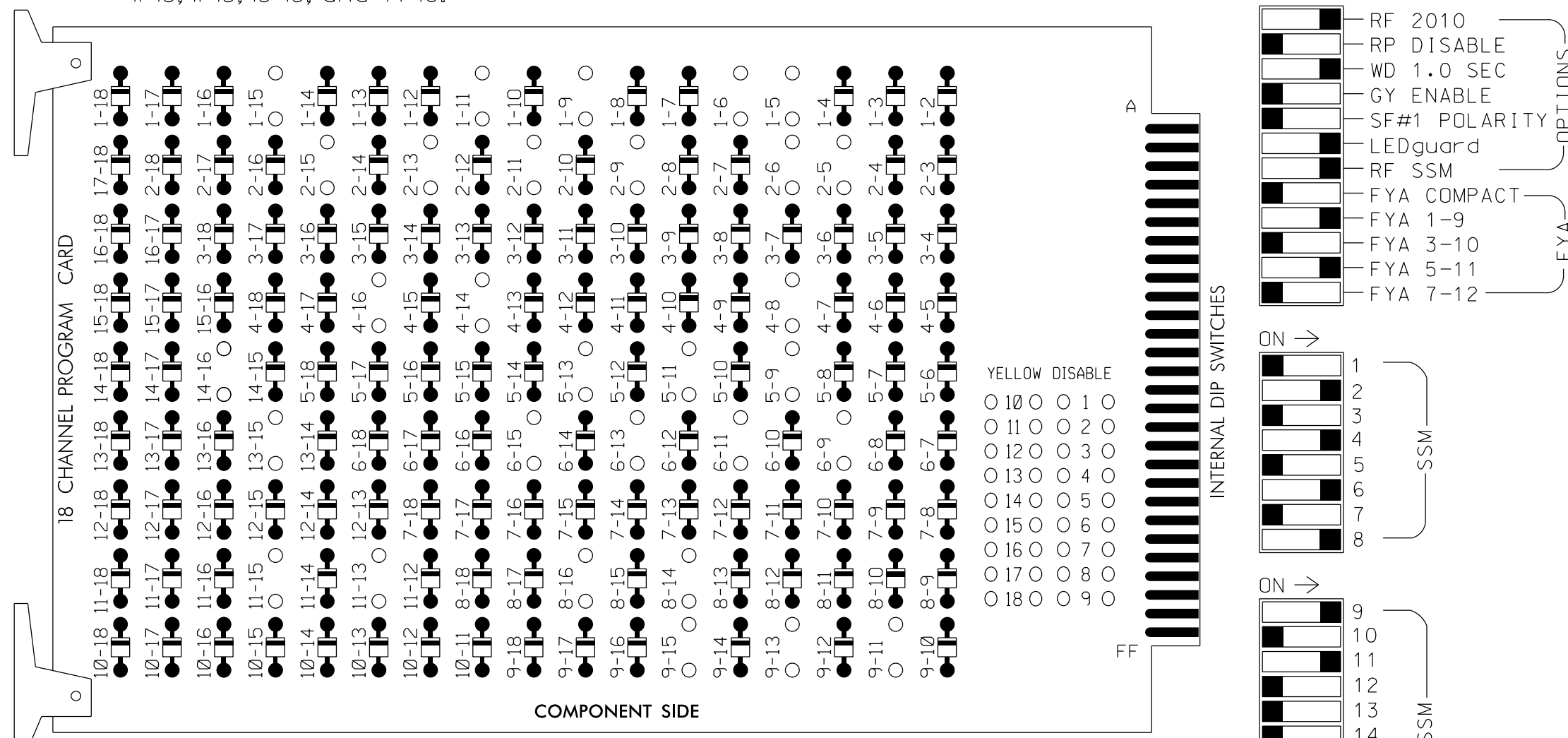

REMOVE JUMPERS AS SHOWN

NOTES:

- Card is provided with all diode jumpers in place. Removal of any jumper allows its channels to run concurrently.
- Ensure jumpers SEL2-SEL5 and SEL9 are present on the monitor board.
- Ensure that Red Enable is active at all times during normal operation.
- Integrate monitor with Ethernet network in cabinet.

NOTES

- To prevent "flash-conflict" problems, insert red flash program blocks for all unused vehicle load switches in the output file. The installer shall verify that signal heads flash in accordance with the Signal Plans.
- Program phases 4 and 8 for Dual Entry.
- Program controller to start up in phase 2 Walk and 6 Walk.
- The cabinet and controller are part of the Burlington-Graham Signal System.

EQUIPMENT INFORMATION

CONTROLLER.....2070LX
 CABINET.....332 W/AUX
 SOFTWARE.....ECONOLITE ASC/3-2070
 CABINET MOUNT.....BASE
 LOAD SWITCHES USED.....S1,S2,S3,S5,S6,S7,S8,S9,
 S11,S12,AUX S1,AUX S4
 PHASES USED.....1,2,2PED,4,4PED,5,6,6PED,
 8,8PED
 OVERLAP "A".....*
 OVERLAP "B".....NOT USED
 OVERLAP "C".....*
 OVERLAP "D".....NOT USED
 * See sheet 2 for overlap programming.

SIGNAL HEAD HOOK-UP CHART

LOAD SWITCH NO.	S1	S2	S3	S4	S5	S6	S7	S8	S9	S10	S11	S12	AUX S1	AUX S2	AUX S3	AUX S4	AUX S5	AUX S6
CMU CHANNEL NO.	1	2	13	3	4	14	5	6	15	7	8	16	9	10	17	11	12	18
PHASE	1	2	2 PED	3	4	4 PED	5	6	6 PED	7	8	8 PED	OLA	OLB	SPARE	DLC	OLD	SPARE
SIGNAL HEAD NO.	11	21,22	P21, P22	NU	41,42	P41, P42	51	61,62	P61, P62	NU	81,82	P81, P82	11	NU	NU	51	NU	NU
RED		128			101			134			107							
YELLOW	*	129			102		*	135			108							
GREEN		130			103			136			109							
RED ARROW													A121				A114	
YELLOW ARROW													A122				A115	
FLASHING YELLOW ARROW													A123				A116	
GREEN ARROW	127							133										
Hand				113			104		119				110					
Person				115			106		121				112					

NU = Not Used
 * See pictorial of head wiring in detail this sheet.
 * Denotes install load resistor. See load resistor installation detail this sheet.

INPUT FILE POSITION LAYOUT

(front view)

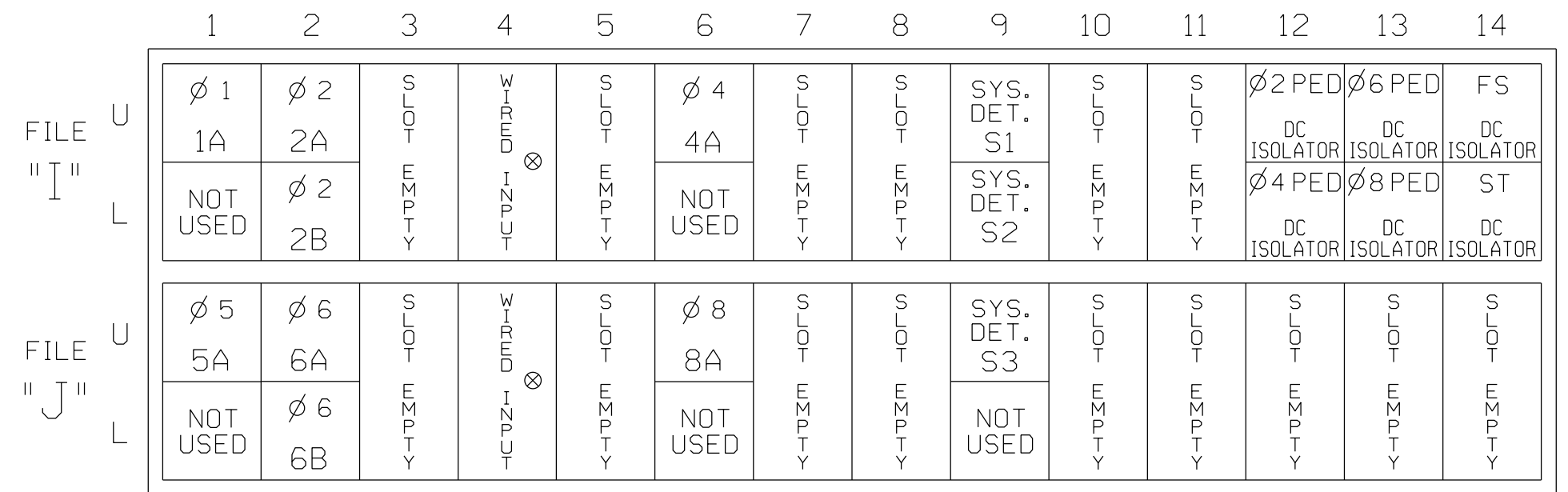

EX.: 1A, 2A, ETC. = LOOP NO.'S
 FS = FLASH SENSE
 ST = STOP TIME

LOAD RESISTOR INSTALLATION DETAIL

(install resistors as shown)

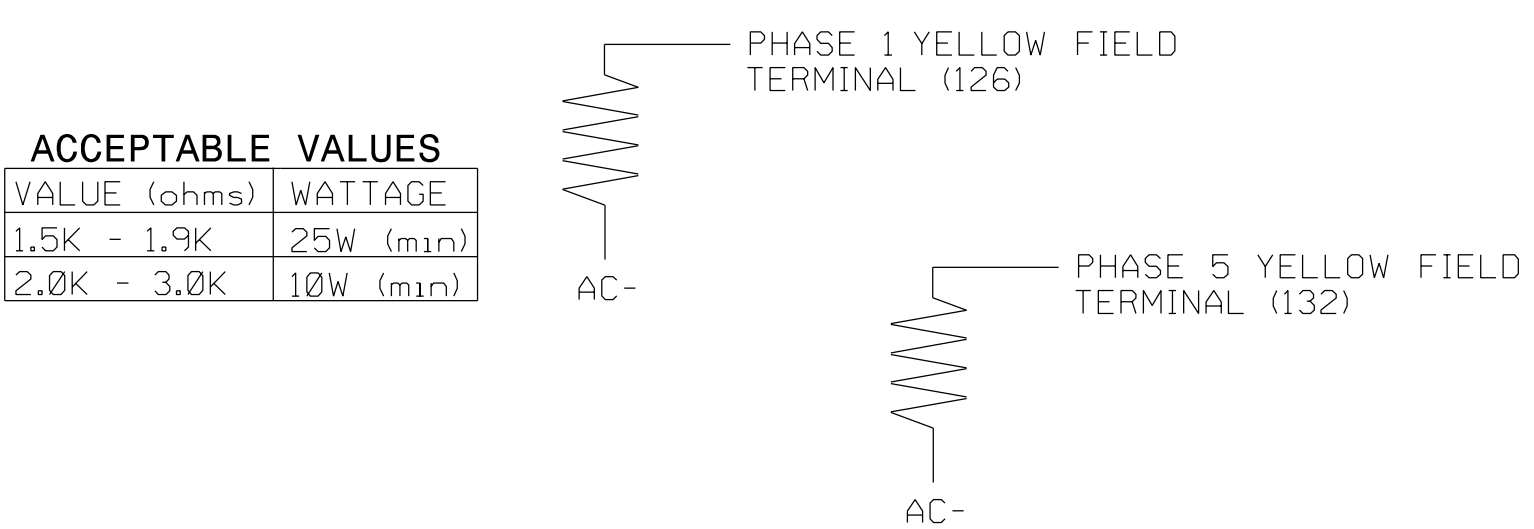

INPUT FILE CONNECTION & PROGRAMMING CHART

LOOP NO.	LOOP TERMINAL	INPUT FILE POS.	PIN NO.	DETECTOR NO.	NEMA PHASE	CALL	EXTEND TIME	DELAY TIME	ADDED INITIAL	DETECTOR TYPE
1A ¹	TB2-1,2	I1U	56	1	1	YES		15		S
	-	J4U	48	26	6	YES				S
2A	TB2-5,6	I2U	39	2	2	YES				S
2B	TB2-7,8	I2L	43	12	2	YES				S
4A	TB4-9,10	I6U	41	4	4	YES		5		S
* S1	TB6-9,10	I9U	60	11	SYS	NO				N
* S2	TB6-11,12	I9L	62	13	SYS	NO				N
5A ²	TB3-1,2	J1U	55	5	5	YES		15		S
	-	I4U	47	22	2	YES				S
6A	TB3-5,6	J2U	40	6	6	YES				S
6B	TB3-7,8	J2L	44	16	6	YES				S
8A	TB5-9,10	J6U	42	8	8	YES		5		S
* S3	TB7-9,10	J9U	59	15	SYS	NO				N

NOTE:
 INSTALL DC ISOLATORS IN INPUT FILE SLOTS 112 AND 113.

- Add jumper from I1-W to J4-W, on rear of input file.
 - Add jumper from J1-W to I4-W, on rear of input file.
- * System detector only. Remove any assigned vehicle phase.

INPUT FILE POSITION LEGEND: J2L

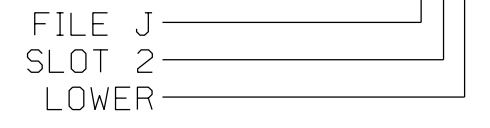

FYA SIGNAL WIRING DETAIL

(wire signal heads as shown)

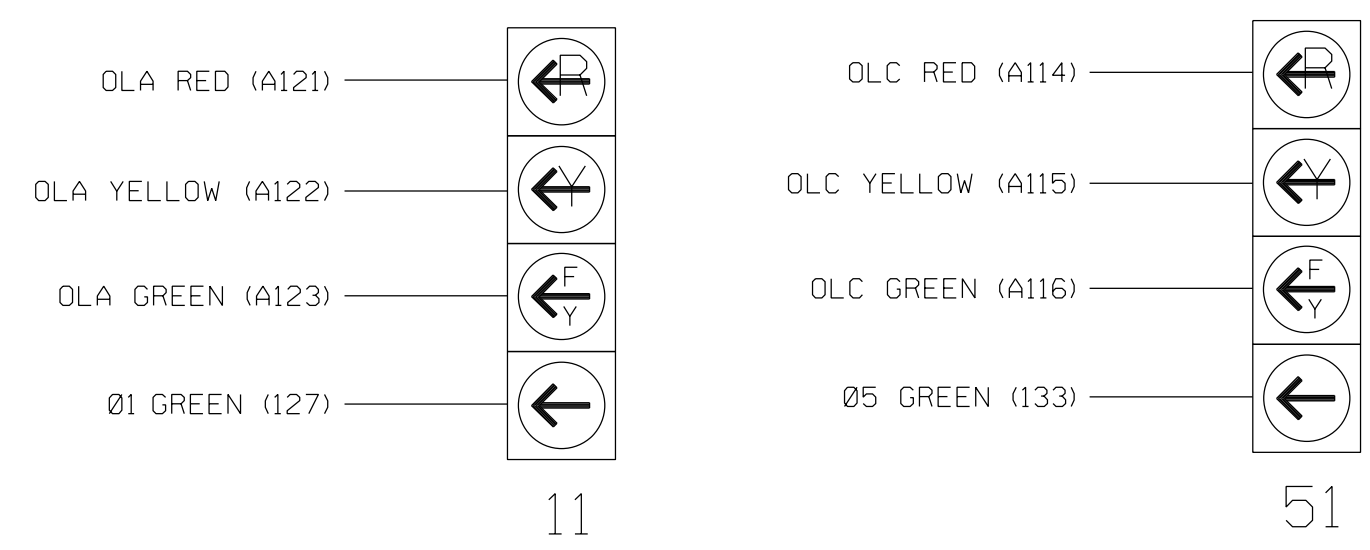

Electrical Detail - Sheet 1 of 2

DOCUMENT NOT CONSIDERED FINAL UNLESS ALL SIGNATURES COMPLETED

SEAL
 NORTH CAROLINA PROFESSIONAL ENGINEER
 PAMELA L. ALEXANDER
 SEAL 023489

Division 7 Alamance County Burlington
 SR 1306 (S. Mebane Street) at Delaney Drive
 PLAN DATE: February 2018 REVIEWED BY: AM Encarnacion
 PREPARED BY: NA Ptak REVIEWED BY: PL Alexander
 REVISIONS INIT. DATE
 6/27/2018
 SIG. INVENTORY NO. 07-1731

27-JUN-2018 17:28
 \\work\ms.com\proj\elect\MSL\krt\transportation\tr\off\cur**00056469 U-6015 B-C S1a Sys*task 05-11\Sigma\Design\wlr\mgw07-1731E.dgn
 AL23361 - AT LUS40649

ECONOLITE ASC/3-2070 OVERLAP PROGRAMMING DETAIL

(program controller as shown)

1. From Main Menu select 2. CONTROLLER
2. From CONTROLLER Submenu select 2. VEHICLE OVERLAPS

OVERLAP A

Select TMG VEH OVLP [A] and 'PPLT FYA'

```

TMG VEH OVLP...[A] TYPE: ....PPLT FYA
PROTECTED LEFT TURN.... PHASE 1
OPPOSING THROUGH..... PHASE 2

FLASHING ARROW OUTPUT.....CH9 ISOLATE
DELAY START OF: FYA..0.0 CLEARANCE..0.0
ACTION PLAN SF BIT DISABLE..... 0
        
```

Toggle Twice

OVERLAP C

Select TMG VEH OVLP [C] and 'PPLT FYA'

```

TMG VEH OVLP...[C] TYPE: ....PPLT FYA
PROTECTED LEFT TURN.... PHASE 5
OPPOSING THROUGH..... PHASE 6

FLASHING ARROW OUTPUT.....CH11 ISOLATE
DELAY START OF: FYA..0.0 CLEARANCE..0.0
ACTION PLAN SF BIT DISABLE..... 0
        
```

END PROGRAMMING

COUNTDOWN PEDESTRIAN SIGNAL OPERATION

Countdown Ped Signals are required to display timing only during Ped Clearance Interval. Consult Ped Signal Module user's manual for instructions on selecting this feature.

THIS ELECTRICAL DETAIL IS FOR
 THE SIGNAL DESIGN: 07-1731
 DESIGNED: February 2018
 SEALED: 6/7/2018
 REVISED: N/A

09-JUN-2018 14:15
 D:\P\consort\at\off\c\cur\100056469 U-6015 B-G S1g Sys\Task 05_11_Signal\Des\gn\mtr\ing\07-1731E.dgn
 ALEX3361 AT LUS210649

Electrical Detail - Sheet 2 of 2

DOCUMENT NOT CONSIDERED
FINAL UNLESS ALL
SIGNATURES COMPLETED

ELECTRICAL AND PROGRAMMING
DETAILS FOR:

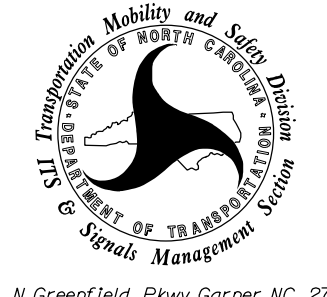
Prepared for the Offices of:

 Mobility and Safety Division
 STATE OF NORTH CAROLINA
 DEPARTMENT OF TRANSPORTATION
 Signal Management Section

SR 1306 (S. Mebane Street) at Delaney Drive	
Division 7	Alamance County Burlington
PLAN DATE: February 2018	REVIEWED BY: AM Encarnacion
PREPARED BY: NA Ptak	REVIEWED BY: PL Alexander
REVISIONS	INIT. DATE

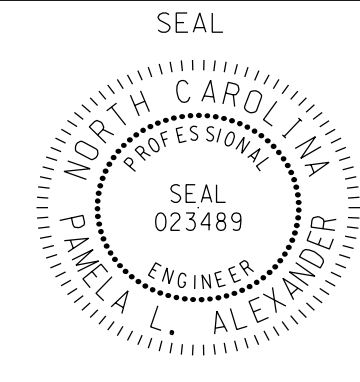
SEAL



SEAL
023489
PAMELA L. ALEXANDER
ENGINEER

6/9/2018
 Date
 Signature: Pamela Alexander
 Date
 Signature: _____
 Date
 Signature: _____

SIG. INVENTORY NO. 07-1731

ATKINS

1616 EAST MILLBROOK ROAD, SUITE 160
 RALEIGH, NORTH CAROLINA 27609
 (919) 876-6888 NCBEEES #F-0326

750 N. Greenfield Pkwy, Garner, NC 27529

PHASING DIAGRAM

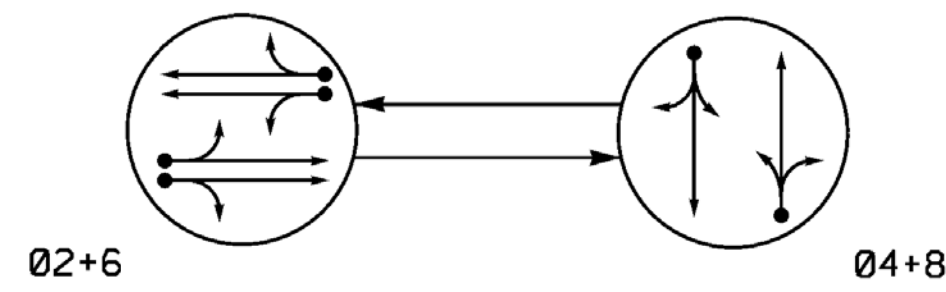

PHASING DIAGRAM DETECTION LEGEND

- → DETECTED MOVEMENT
- → UNDETECTED MOVEMENT (OVERLAP)
- → UNSIGNALIZED MOVEMENT
- ⚡ → PEDESTRIAN MOVEMENT

TABLE OF OPERATION

SIGNAL FACE	PHASE		
	02+6	04+8	FLASH
21,22	G	R	Y
41,42	R	G	R
61,62	G	R	Y
81,82	R	G	R

SIGNAL FACE I.D.

All Heads L.E.D.

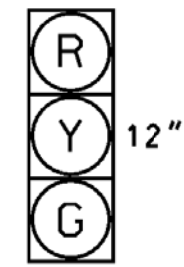

21,22
41,42
61,62
81,82

ASC/3 DETECTOR INSTALLATION CHART											
DETECTOR						PROGRAMMING					
LOOP	SIZE (FT)	DISTANCE FROM STOPBAR (FT)	TURNS	NEW LOOP	PHASE	CALLING	EXTEND TIME	DELAY TIME	USE ADDED INITIAL	TYPE	NEW CARD
2A	6x6	300	5	-	2	Yes	-	-	X	N	X
2B	6x6	300	5	-	2	Yes	-	-	X	N	X
4A	6x60	0	2-4-2	-	4	Yes	-	10	-	S	X
6A	6x6	300	5	-	6	Yes	-	-	X	N	X
6B	6x6	300	5	-	6	Yes	-	-	X	N	X
8A	6x60	0	2-4-2	-	8	Yes	-	15	-	S	X

2 Phase Fully Actuated (Burlington-Graham Signal System)

NOTES

- Refer to "Roadway Standard Drawings NCDOT" dated January 2018 and "Standard Specifications for Roads and Structures" dated January 2018.
- Do not program signal for late night flashing operation unless otherwise directed by the Engineer.
- Set all detector units to presence mode.
- In the event of loop replacement, refer to the current ITS and Signals Design Manual and submit a Plan of Record to the Signal Design Section.
- Locate new cabinet so as not to obstruct sight distance of vehicles turning right on red.
- The cabinet should be designed to include an Auxiliary Output file for future use.
- Pavement markings are existing.
- Maximum times shown in timing chart are for free-run operation only. Coordinated signal system timing values supersede these values.

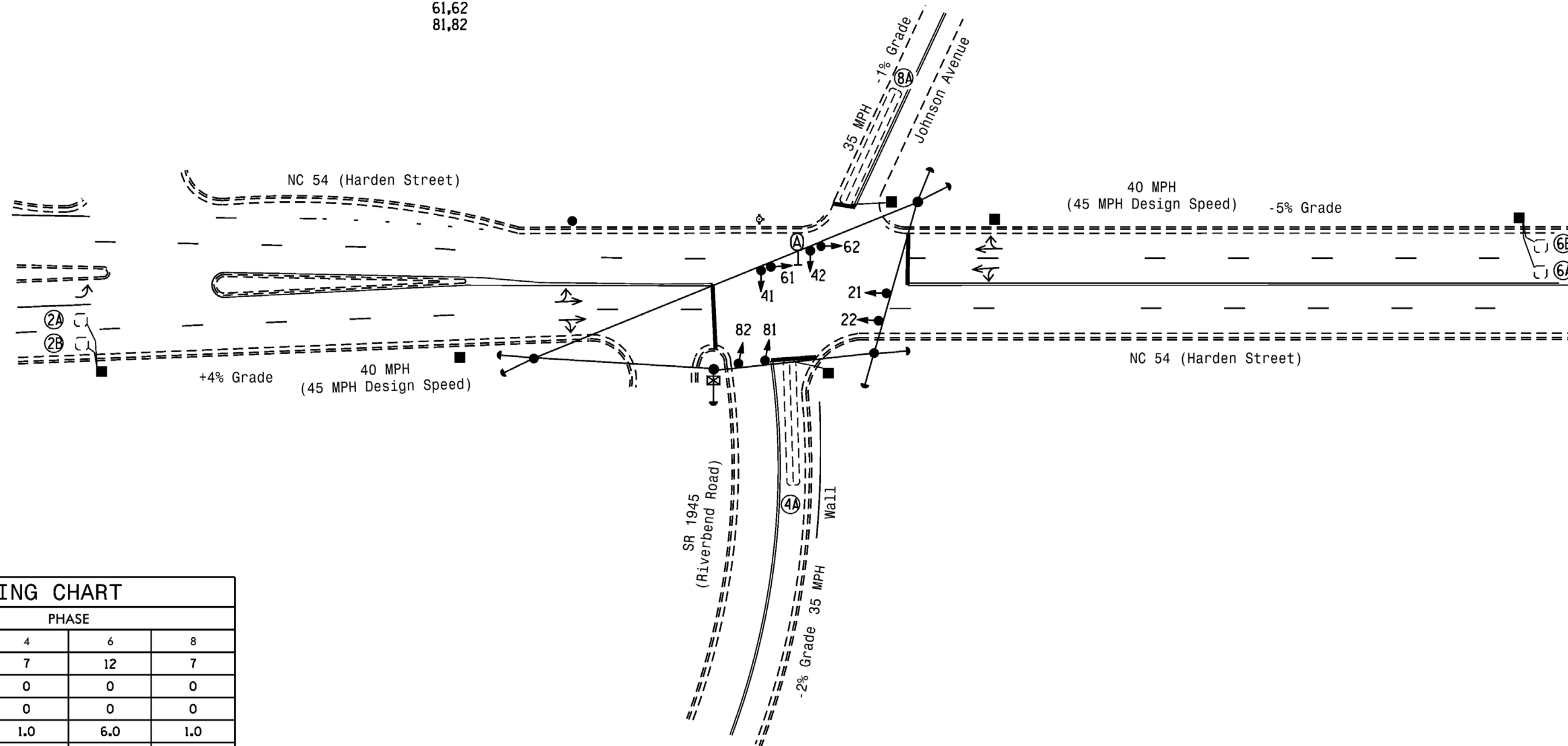

ASC/3 TIMING CHART

FEATURE	PHASE			
	2	4	6	8
Min Green *	12	7	12	7
Walk *	0	0	0	0
Ped Clear	0	0	0	0
Veh. Extension *	6.0	1.0	6.0	1.0
Max I *	90	35	90	35
Yellow	4.2	4.0	5.0	3.9
Red Clear	1.4	1.4	1.0	1.5
Actuations B4 Add *	0	-	0	-
Seconds / Actuation *	1.5	-	1.5	-
Max Initial *	34	-	34	-
Time Before Reduction *	20	-	20	-
Time To Reduce *	40	-	40	-
Minimum Gap	3.0	-	3.0	-
Locking Detector	X	-	X	-
Recall Position	VEH. RECALL	-	VEH. RECALL	-
Dual Entry	-	X	-	X
Simultaneous Gap	X	X	X	X

* These values may be field adjusted. Do not adjust Min Green and Extension times for phases 2 and 6 lower than what is shown. Min Green for all other phases should not be lower than 4 seconds.

LEGEND

- | PROPOSED | EXISTING |
|--|--|
| ○ → Traffic Signal Head | ● → N/A |
| ● → Modified Signal Head | ○ → N/A |
| ⊥ Sign | ⊥ Sign |
| ⊥ Pedestrian Signal Head With Push Button & Sign | ⊥ Pedestrian Signal Head With Push Button & Sign |
| ○ Signal Pole with Guy | ○ Signal Pole with Guy |
| ○ Signal Pole with Sidewalk Guy | ○ Signal Pole with Sidewalk Guy |
| ⊠ Inductive Loop Detector | ⊠ Inductive Loop Detector |
| ⊠ Controller & Cabinet | ⊠ Controller & Cabinet |
| ⊠ Junction Box | ⊠ Junction Box |
| --- 2-in Underground Conduit | --- 2-in Underground Conduit |
| N/A Right of Way | N/A Right of Way |
| → Directional Arrow | → Directional Arrow |
| N/A "LEFT TURN YIELD ON GREEN" Sign (R10-12) | ⓐ "LEFT TURN YIELD ON GREEN" Sign (R10-12) |

Mattern & Craig
ENGINEERS • SURVEYORS

12 BROAD STREET
ASHEVILLE, NORTH CAROLINA 28801
(828) 254-2201
FAX (828) 254-4562
NC LIC. NO. C-1154

Signal Upgrade

Prepared for the Offices of:
TRANSPORTATION MOBILITY AND SAFETY DIVISION
DEPARTMENT OF TRANSPORTATION
Signal Design Section
750 N. Greenfield Pkwy, Garner, NC 27529
SCALE 1"=40'

DOCUMENT NOT CONSIDERED FINAL UNLESS ALL SIGNATURES COMPLETED

NC 54 (Harden Street) at SR 1945 (Riverbend Road) / Johnson Avenue
Division 7 Alamance County Graham

PLAN DATE: November 2017 REVIEWED BY: JB Voso
PREPARED BY: SE Wilson REVIEWED BY:

REVISIONS INIT. DATE

SEAL NORTH CAROLINA PROFESSIONAL ENGINEER JAMES B. VOSO 022599
6/13/2018
SIG. INVENTORY NO. 07-1771

*****SYTIME*****
*****BUSINESS*****

**EDI MODEL 2018EClip-NC CONFLICT MONITOR
PROGRAMMING DETAIL**

(remove jumpers and set switches as shown)

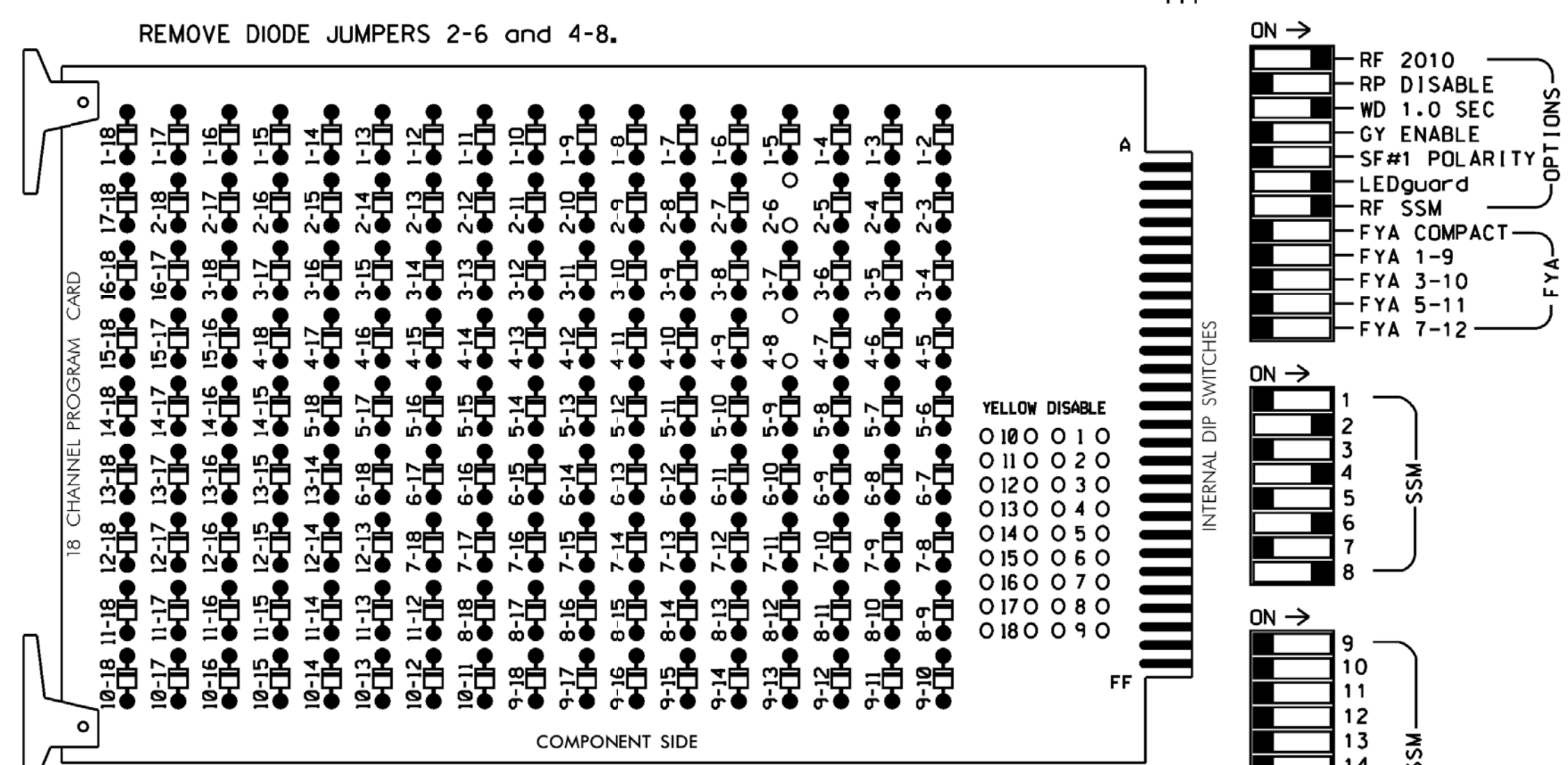

- NOTES:**
- Card is provided with all diode jumpers in place. Removal of any jumper allows its channels to run concurrently.
 - Ensure jumpers SEL2-SEL5 and SEL9 are present on the monitor board.
 - Ensure that Red Enable is active at all times during normal operation.
 - Integrate monitor with Ethernet network in cabinet.

NOTES

- To prevent "flash-conflict" problems, insert red flash program blocks for all unused vehicle load switches in the output file. The installer shall verify that signal heads flash in accordance with the Signal Plans.
- Program phases 4 and 8 for Dual Entry.
- Program controller to start up in phase 2 Green and 6 Green.
- The cabinet and controller are part of the Burlington-Graham Signal System.

SIGNAL HEAD HOOK-UP CHART

LOAD SWITCH NO.	S1	S2	S3	S4	S5	S6	S7	S8	S9	S10	S11	S12	AUX S1	AUX S2	AUX S3	AUX S4	AUX S5	AUX S6
CMU CHANNEL NO.	1	2	13	3	4	14	5	6	15	7	8	16	9	10	17	11	12	18
PHASE	1	2	2 PED	3	4	4 PED	5	6	6 PED	7	8	8 PED	OLA	OLB	SPARE	OLC	OLD	SPARE
SIGNAL HEAD NO.	NU	21,22	NU	NU	41,42	NU	NU	61,62	NU	NU	81,82	NU	NU	NU	NU	NU	NU	NU
RED		128			101			134			107							
YELLOW		129			102			135			108							
GREEN		130			103			136			109							
RED ARROW																		
YELLOW ARROW																		
GREEN ARROW																		

NU = Not Used

EQUIPMENT INFORMATION

CONTROLLER.....2070LX
 CABINET.....332 W/AUX
 SOFTWARE.....ECONOLITE ASC/3-2070
 CABINET MOUNT.....BASE
 OUTPUT FILE POSITIONS...18 WITH AUX. OUTPUT FILE
 LOAD SWITCHES USED.....S2,S5,S8,S11
 PHASES USED.....2,4,6,8
 OVERLAP "A".....NOT USED
 OVERLAP "B".....NOT USED
 OVERLAP "C".....NOT USED
 OVERLAP "D".....NOT USED

INPUT FILE POSITION LAYOUT

(front view)

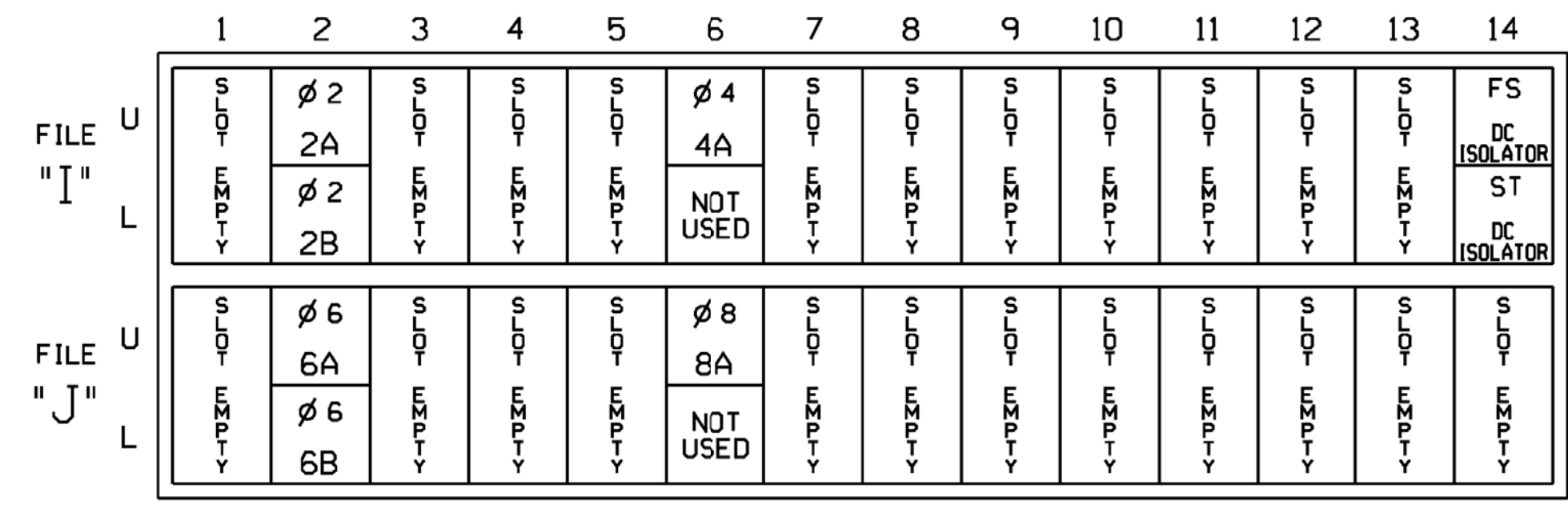

EX. : 1A, 2A, ETC. = LOOP NO.'S

FS = FLASH SENSE
 ST = STOP TIME

INPUT FILE CONNECTION & PROGRAMMING CHART

LOOP NO.	LOOP TERMINAL	INPUT FILE POS.	PIN NO.	DETECTOR NO.	NEMA PHASE	CALL	EXTEND TIME	DELAY TIME	ADDED INITIAL	DETECTOR TYPE
2A	TB2-5,6	I2U	39	2	2	YES			X	N
2B	TB2-7,8	I2L	43	2	2	YES			X	N
4A	TB4-9,10	I6U	41	4	4	YES		10		S
6A	TB3-5,6	J2U	40	6	6	YES			X	N
6B	TB3-7,8	J2L	44	6	6	YES			X	N
8A	TB5-9,10	J6U	42	8	8	YES		15		S

INPUT FILE POSITION LEGEND: J2L

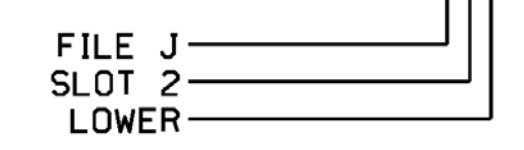

THIS ELECTRICAL DETAIL IS FOR THE SIGNAL DESIGN: 07-1771
 DESIGNED: November 2017
 SEALED: 6/13/2018
 REVISED: NA

*****SYTIME*****
 *****DON*****
 *****USER*****



12 BROAD STREET
 ASHEVILLE, NORTH CAROLINA 28801
 (828) 254-2201
 FAX (828) 254-4562
 NC LIC. NO. C-1154

Electrical Detail

ELECTRICAL AND PROGRAMMING DETAILS FOR: Prepared for the Offices of: 750 N. Greenfield Pkwy, Corner, NC 27529	NC 54 (Harden Street) at SR 1945 (Riverbend Road) /Johnson Avenue		DOCUMENT NOT CONSIDERED FINAL UNLESS ALL SIGNATURES COMPLETED SEAL James Voso 6/13/2018 DATE
	Division 7 Alamance County Graham		
	PLAN DATE: November 2017 PREPARED BY: SE Wilson	REVIEWED BY: JB Voso REVIEWED BY:	
	REVISIONS	INIT. DATE	

PHASING DIAGRAM

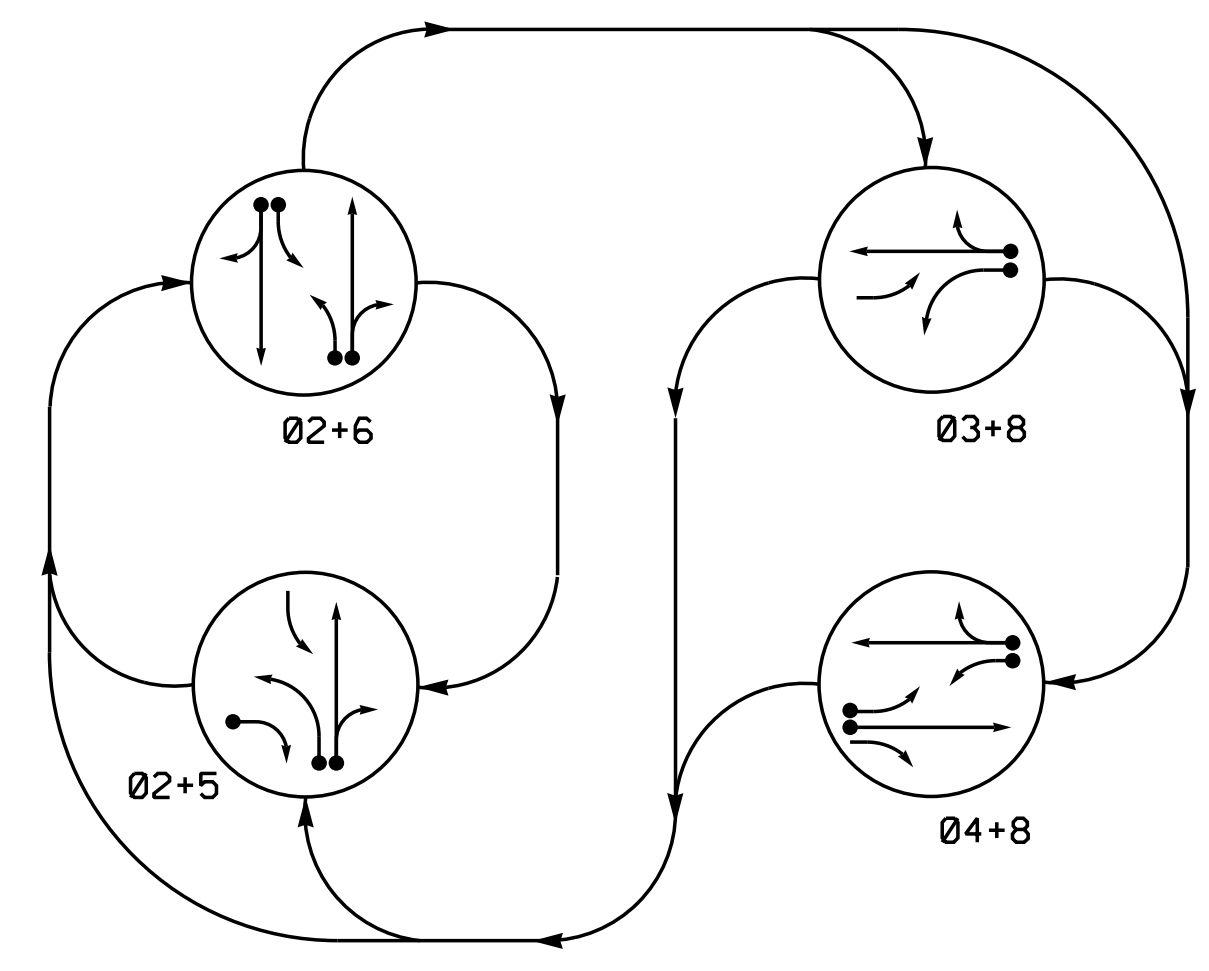

PHASING DIAGRAM DETECTION LEGEND

- ←●→ DETECTED MOVEMENT
- ←○→ UNDETECTED MOVEMENT (OVERLAP)
- UNSIGNALIZED MOVEMENT
- ←- - -> PEDESTRIAN MOVEMENT

SIGNAL FACE	PHASE				
	02+5	02+6	03+8	04+8	F
21,22	G	G	R	R	Y
31	R	R	F	F	R
41	R	R	F	F	R
42	R	R	R	G	R
43	R	R	R	G	R
51	F	F	R	R	Y
61	F	F	R	R	Y
62,63	R	G	R	R	Y
81,82	R	R	G	G	R

SIGNAL FACE I.D.

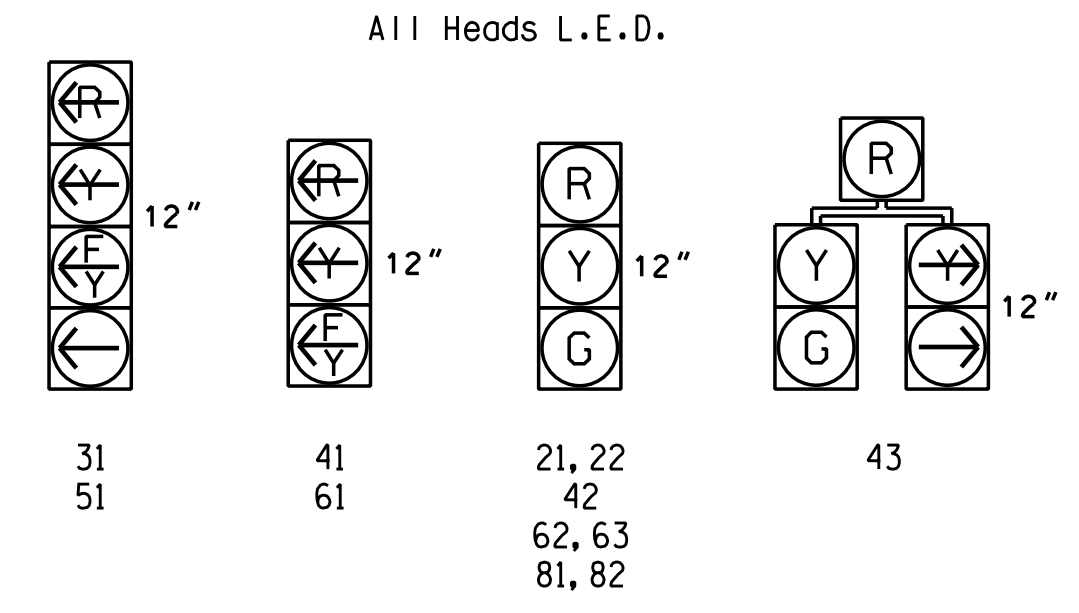

ASC/3 DETECTOR INSTALLATION CHART											
DETECTOR				PROGRAMMING							
LOOP	SIZE (FT)	DISTANCE FROM STOPBAR (FT)	TURNS	NEW LOOP	PHASE	CALLING	EXTEND TIME	DELAY TIME	USE ADDED INITIAL	TYPE	SYSTEM LOOP
2A	6x6	250	EXIST.	-	2	Yes	-	-	X	N	-
2B	6x60	0	2-4-2	-	2	Yes	2.0	5	-	G	-
3A	6x60	+5	2-4-2	-	3	Yes	-	15	-	S	-
4A	6x6	300	EXIST.	-	4	No	2.4	-	-	S	-
4B	6x60	+5	2-4-2	-	4	Yes	-	3	-	S	-
4C	6x40	+5	2-4-2	-	4	Yes	-	-	-	S	-
5A	6x60	0	2-4-2	-	2	Yes	-	3	-	G	-
5B	6x40	+5	2-4-2	-	5	Yes	-	15	-	S	-
6A	6x6	250	EXIST.	-	6	Yes	-	-	X	N	-
6B	6x60	0	2-4-2	-	6	Yes	2.0	5	-	G	-
6C	6x60	0	2-4-2	-	6	Yes	2.0	5	-	G	-
8A	6x6	300	EXIST.	-	8	No	2.4	-	-	S	-
8B	6x40	+5	2-4-2	-	8	Yes	-	10	-	S	-
8C	6x15	+5	EXIST.	-	8	Yes	-	15	-	S	-

4 Phase Fully Actuated (Burlington-Graham Signal System)

NOTES

- Refer to "Roadway Standard Drawings NCDOT" dated January 2018 and "Standard Specifications for Roads and Structures" dated January 2018.
- Do not program signal for late night flashing operation unless otherwise directed by the Engineer.
- Phase 3 may be lagged.
- Phase 5 may be lagged.
- Reposition all existing signal heads as shown.
- Set all detector units to presence mode.
- In the event of loop replacement, refer to the current ITS and Signals Design Manual and submit a Plan of Record to the Signal Design Section.
- Locate new cabinet so as not to obstruct sight distance of vehicles turning right on red.
- Existing Left Arrow "ONLY" sign(s)-(R3-5L) may be removed at the discretion of the Regional Traffic Engineer.
- Pavement markings are existing.
- Maximum times shown in timing chart are for free-run operation only. Coordinated signal system timing values supersede these values.

FEATURE	ASC/3 TIMING CHART						
	2	3	4	5	6	8	
Min Green *	12	7	12	7	12	12	
Walk *	0	0	0	0	0	0	
Ped Clear	0	0	0	0	0	0	
Veh. Extension *	6.0	1.0	2.0	1.0	6.0	2.0	
Max 1 *	90	20	45	25	90	45	
Yellow	4.2	3.0	4.7	3.0	4.2	4.7	
Red Clear	1.4	3.1	1.4	1.6	1.4	1.4	
Actuations B4 Add *	-	-	-	-	-	-	
Seconds / Actuation *	-	-	-	-	-	-	
Max Initial *	-	-	-	-	-	-	
Time Before Reduction *	30	-	-	-	30	-	
Time To Reduce *	30	-	-	-	30	-	
Minimum Gap	3.0	-	-	-	3.0	-	
Locking Detector	-	-	-	-	-	-	
Recall Position	-	-	-	-	-	-	
Dual Entry	-	-	X	-	-	X	
Simultaneous Gap	X	X	X	X	X	X	

* These values may be field adjusted. Do not adjust Min Green and Extension times for phases 2 and 6 lower than what is shown. Min Green for all other phases should not be lower than 4 seconds.

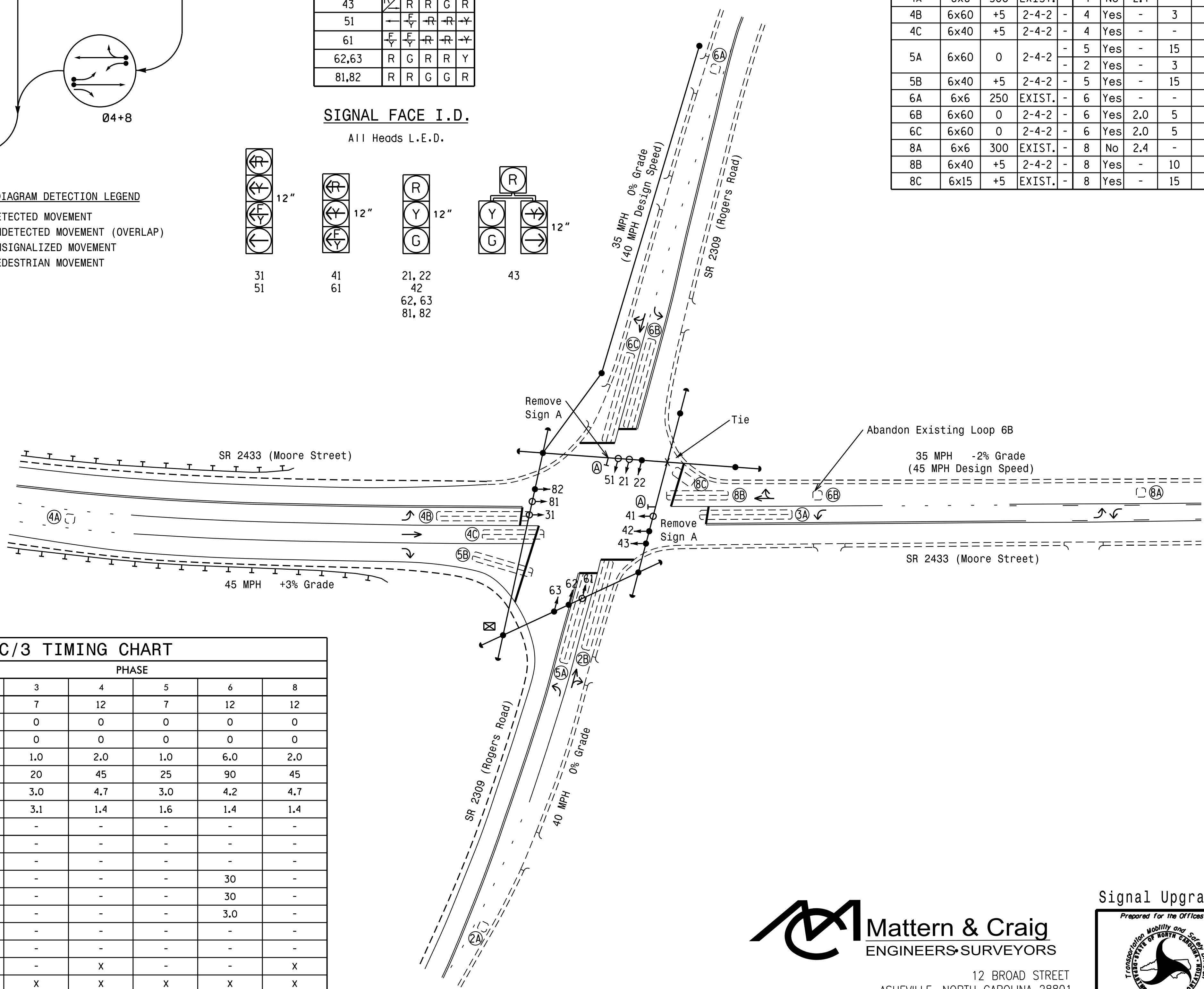

LEGEND	
PROPOSED	EXISTING
○→ Traffic Signal Head	●→ Traffic Signal Head
○→ Modified Signal Head	N/A
⊥ Sign	⊥ Sign
⊥ Pedestrian Signal Head With Push Button & Sign	⊥ Pedestrian Signal Head With Push Button & Sign
○ Signal Pole with Guy	○ Signal Pole with Guy
○ Signal Pole with Sidewalk Guy	○ Signal Pole with Sidewalk Guy
⊠ Controller & Cabinet	⊠ Controller & Cabinet
□ Junction Box	□ Junction Box
--- 2-in Underground Conduit	--- 2-in Underground Conduit
N/A Right of Way	--- Right of Way
→ Directional Arrow	→ Directional Arrow
Ⓐ Left Arrow "ONLY" Sign (R3-5L)	Ⓐ Left Arrow "ONLY" Sign (R3-5L)

Mattern & Craig
ENGINEERS-SURVEYORS

12 BROAD STREET
ASHEVILLE, NORTH CAROLINA 28801
(828) 254-2201
FAX (828) 254-4562
NC LIC. NO. C-1154

Signal Upgrade

Division 7 Alamance County Graham

SR 2433 (Moore Street) at SR 2309 (Rogers Road)

PLAN DATE: November 2017 REVIEWED BY: JB Voso

PREPARED BY: SE Wilson REVIEWED BY:

REVISIONS: INIT. DATE

6/13/2018

SIGNATURE: James B. Voso

SIG. INVENTORY NO. 07-1804

4:14:51 PM C:\Burlington-Graham Signal System\06 Working Folders\Replace Sub-folders with NCDOT File Structure If Working on NCDOT Project\DWG or Dgn\07-1804-01804.sig.dgn, 20170316.dgn

EDI MODEL 2018ECLIP-NC CONFLICT MONITOR PROGRAMMING DETAIL

(remove jumpers and set switches as shown)

REMOVE DIODE JUMPERS 2-5, 2-6, 2-9, 2-11, 3-8, 3-10, 3-12, 4-8, 4-10, 4-12, 5-9, 5-11, 6-9, 6-11, 8-10, 8-12, 9-11, and 10-12.

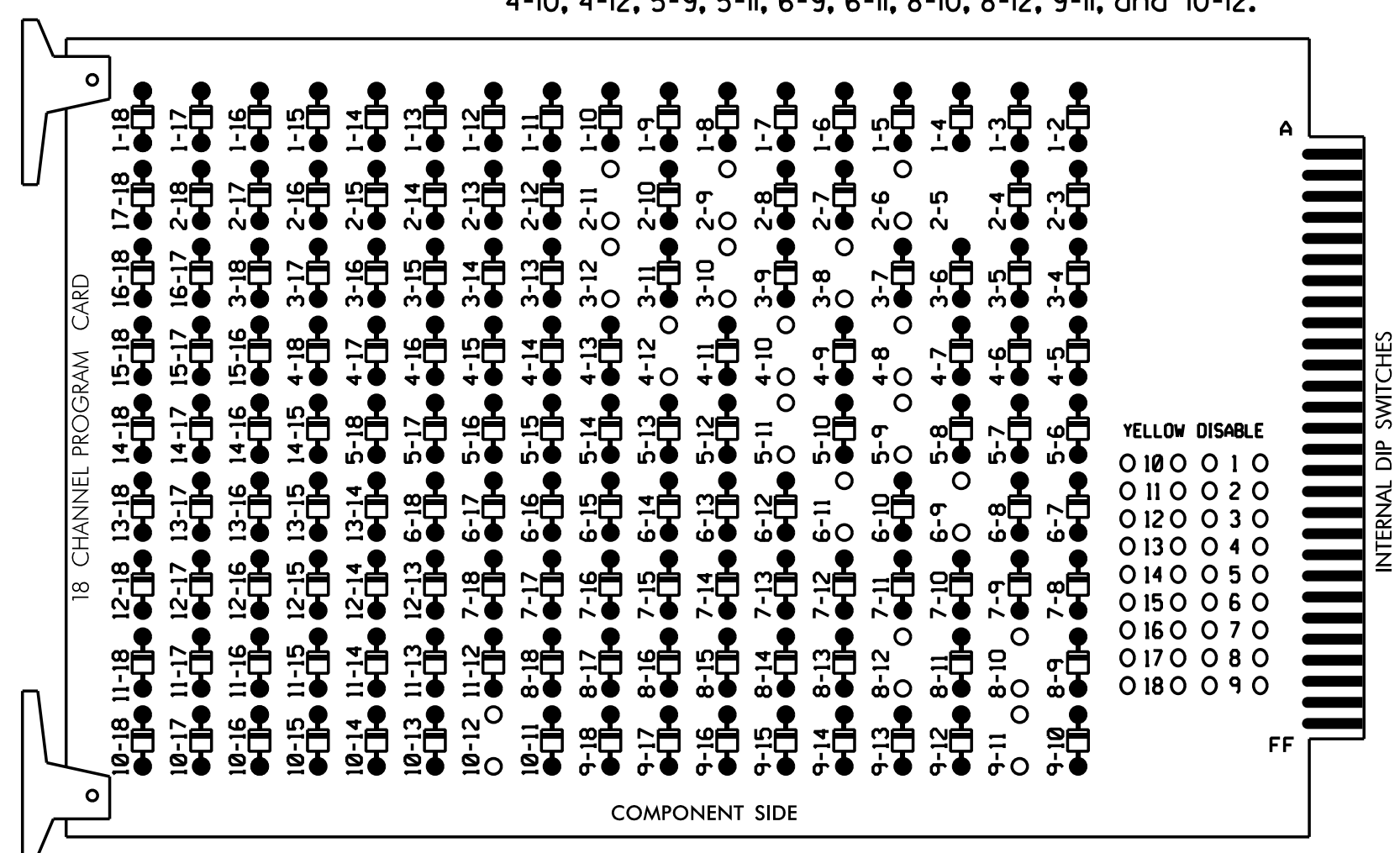

REMOVE JUMPERS AS SHOWN

NOTES:

- Card is provided with all diode jumpers in place. Removal of any jumper allows its channels to run concurrently.
- Ensure jumpers SEL2-SEL5 and SEL9 are present on the monitor board.
- Ensure that Red Enable is active at all times during normal operation.
- Integrate monitor with Ethernet network in cabinet.

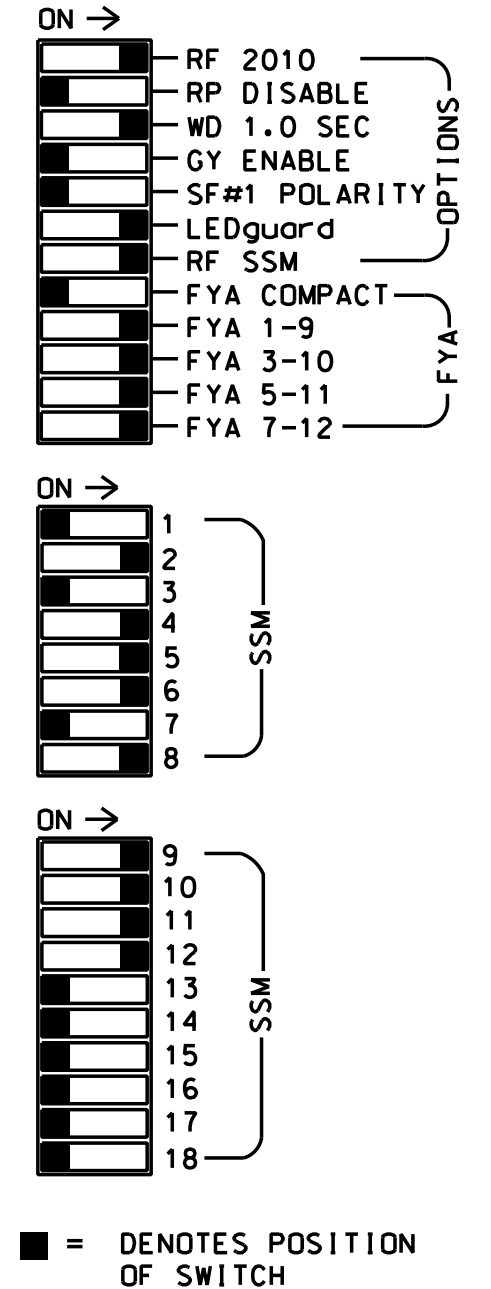

NOTES

- To prevent "flash-conflict" problems, insert red flash program blocks for all unused vehicle load switches in the output file. The installer shall verify that signal heads flash in accordance with the Signal Plans.
- Program phases 4 and 8 for Dual Entry.
- Program controller to start up in phase 2 Green and 6 Green.
- The cabinet and controller are part of the Burlington-Graham Signal System.

EQUIPMENT INFORMATION

CONTROLLER.....2070LX
 CABINET.....332 W/ AUX
 SOFTWARE.....ECONOLITE ASC/3-2070
 CABINET MOUNT.....BASE
 OUTPUT FILE POSITIONS...18 WITH AUX. OUTPUT FILE LOAD SWITCHES USED.....S2,S4,S5,S7,S8,S11,AUX S1, AUX S2,AUX S4,AUX S5
 PHASES USED.....2,3,4,5,6,8
 OVERLAP A.....*
 OVERLAP B.....*
 OVERLAP C.....*
 OVERLAP D.....*
 * See overlap programming detail on sheet 2

SIGNAL HEAD HOOK-UP CHART

LOAD SWITCH NO.	S1	S2	S3	S4	S5	S6	S7	S8	S9	S10	S11	S12	AUX S1	AUX S2	AUX S3	AUX S4	AUX S5	AUX S6	
CMU CHANNEL NO.	1	2	13	3	4	14	5	6	15	7	8	16	9	10	17	11	12	18	
PHASE	1	2	2 PED	3	4	4 PED	5	6	6 PED	7	8	8 PED	OLA	OLB	SPARE	OLC	OLD	SPARE	
SIGNAL HEAD NO.	NU	21,22	NU	31	42,43	NU	43	51	62,63	NU	NU	81,82	NU	61	31	NU	51	41	NU
RED		128			101		*		134			107							
YELLOW		129		*	102				135			108							
GREEN		130			103				136			109							
RED ARROW																A121	A124	A114	A101
YELLOW ARROW																A122	A125	A115	A102
FLASHING YELLOW ARROW																A123	A126	A116	A103
GREEN ARROW							118		133	133									

NU = Not Used

* Denotes install load resistor. See load resistor installation detail this sheet.

★ See pictorial of head wiring in detail this sheet.

INPUT FILE POSITION LAYOUT

(front view)

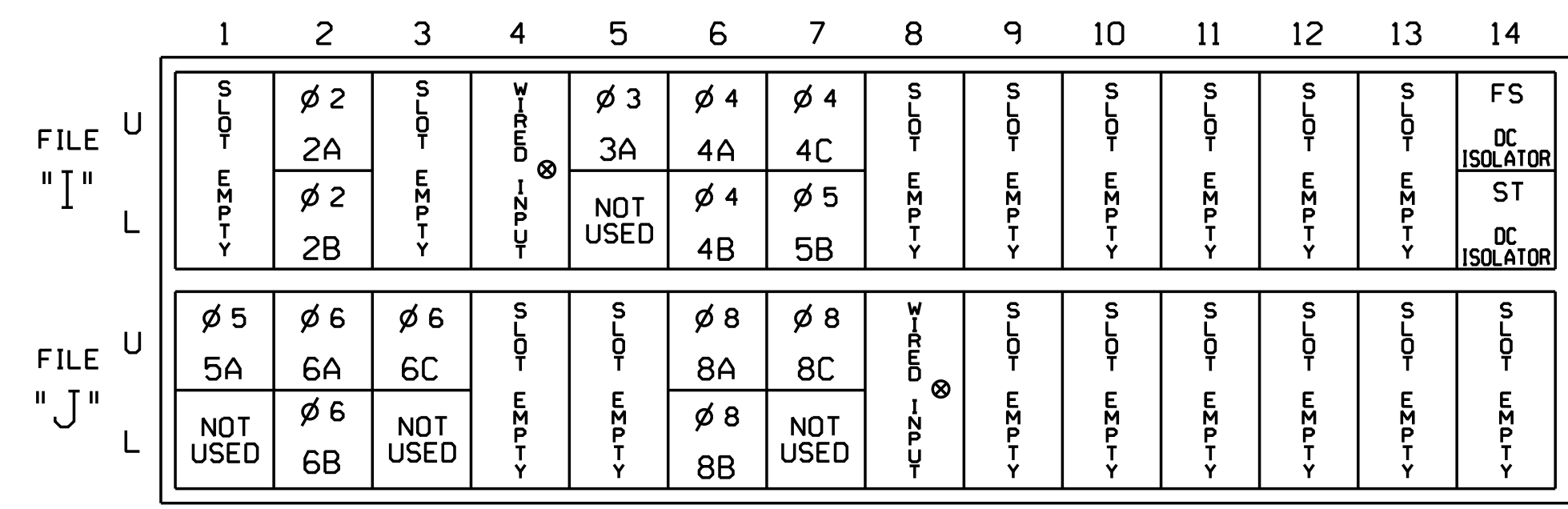

EX.: 1A, 2A, ETC. = LOOP NO.'S
 FS = FLASH SENSE
 ST = STOP TIME
 ⊗ Wired Input - Do not populate slot with detector card.

INPUT FILE CONNECTION & PROGRAMMING CHART

LOOP NO.	LOOP TERMINAL	INPUT FILE POS.	PIN NO.	DETECTOR NO.	NEMA PHASE	CALL	EXTEND TIME	DELAY TIME	ADDED INITIAL	DETECTOR TYPE
2A	TB2-5,6	I2U	39	2	2	YES			X	N
2B	TB2-7,8	I2L	43	12	2	YES	2.0	5		G
3A ¹	TB4-5,6	I5U	58	3	3	YES		15		S
		J8U	50	28	8	YES				S
4A	TB4-9,10	I6U	41	4	4	NO	2.4			S
4B	TB4-11,12	I6L	45	14	4	YES		3		S
4C	TB6-1,2	I7U	65	34	4	YES				S
5A ²	TB3-1,2	J1U	55	5	5	YES		15		S
		I4U	47	22	2	YES		3		G
5B	TB6-3,4	I7L	78	44	5	YES		15		S
6A	TB3-5,6	J2U	40	6	6	YES			X	N
6B	TB3-7,8	J2L	44	16	6	YES	2.0	5		G
6C	TB3-9,10	J3U	64	36	6	YES	2.0	5		G
8A	TB5-9,10	J6U	42	8	8	NO	2.4			S
8B	TB5-11,12	J6L	46	18	8	YES		10		S
8C	TB7-1,2	J7U	66	38	8	YES		15		S

¹Add jumper from I5-W to J8-W, on rear of input file.
²Add jumper from J1-W to I4-W, on rear of input file.

INPUT FILE POSITION LEGEND: J2L

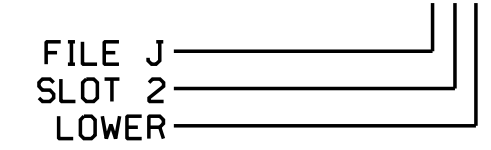

FYA SIGNAL WIRING DETAIL

(wire signal heads as shown)

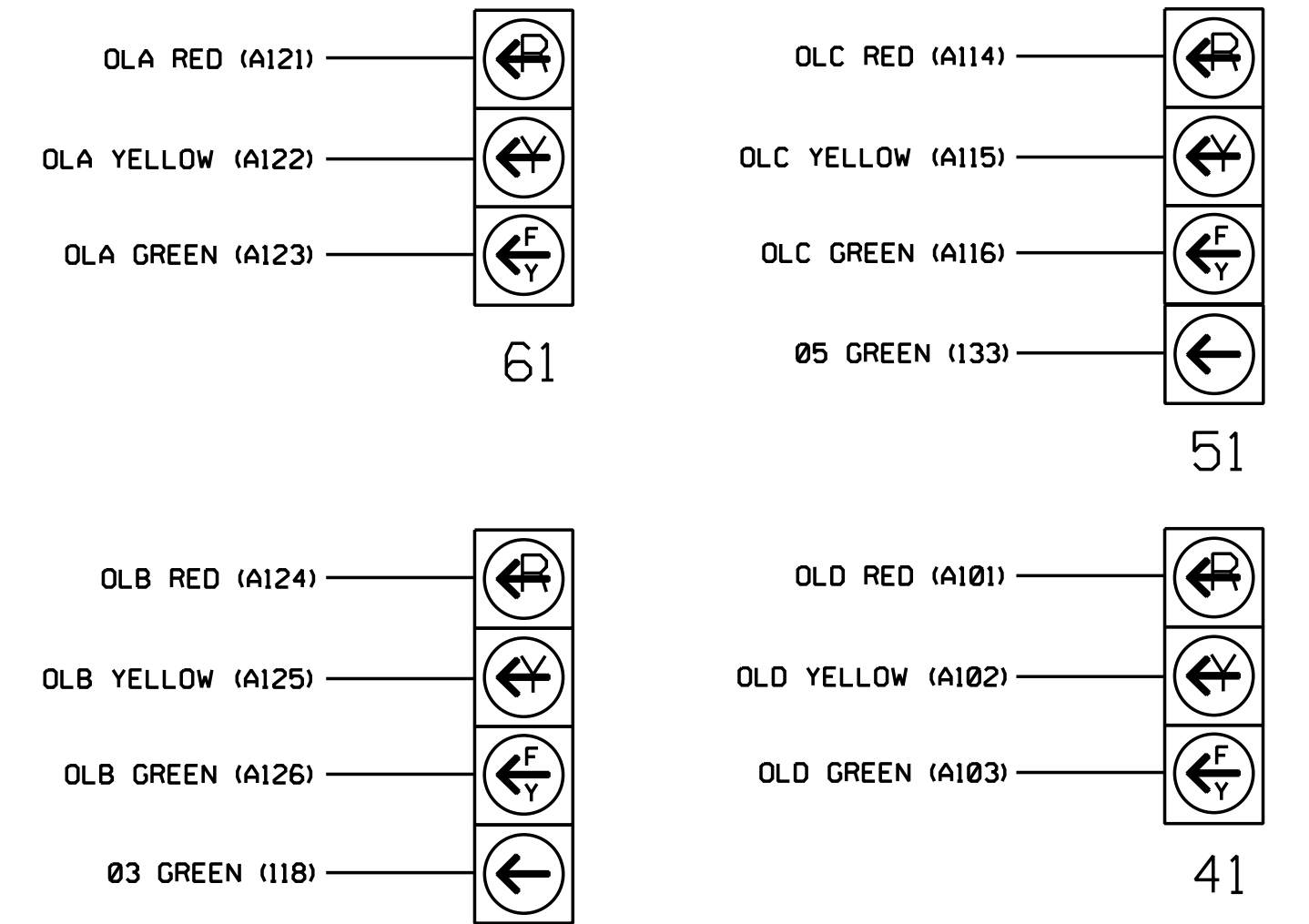

LOAD RESISTOR INSTALLATION DETAIL

(install resistors as shown)

VALUE (ohms)	WATTAGE
1.5K - 1.9K	25W (min)
2.0K - 3.0K	10W (min)

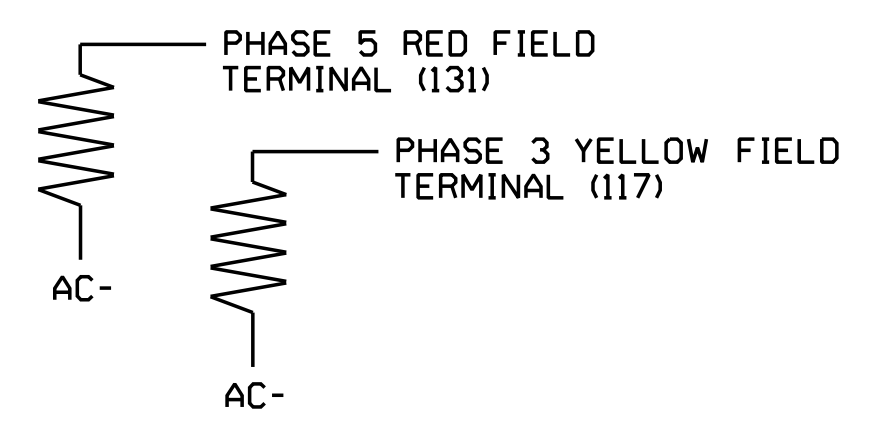

Mattern & Craig
 ENGINEERS-SURVEYORS

12 BROAD STREET
 ASHEVILLE, NORTH CAROLINA 28801
 (828) 254-2201
 FAX (828) 254-4562
 NC LIC. NO. C-1154

Electrical Detail - Sheet 1 of 2

ELECTRICAL AND PROGRAMMING DETAILS FOR: Prepared for the Offices of: 750 N. Greenfield Pkwy, Corner, NC 27529	SR 2433 (Moore Street) at SR 2309 (Rogers Road)		DOCUMENT NOT CONSIDERED FINAL UNLESS ALL SIGNATURES COMPLETED SEAL SEAL JAMES B. VOSO ENGINEER 6/13/2018 DATE
	Division 7 PLAN DATE: November 2017 PREPARED BY: SE Wilson	Alamance County REVIEWED BY: JB Voso REVIEWED BY:	

ECONOLITE ASC/3-2070 OVERLAP PROGRAMMING DETAIL

(program controller as shown)

1. From Main Menu select 2. CONTROLLER
2. From CONTROLLER Submenu select 2. VEHICLE OVERLAPS

OVERLAP A

Select TMG VEH OVLP [A] and 'OTHER/ECONOLITE'

```

TMG VEH OVLP...[A] TYPE: OTHER/ECONOLITE
PHASES 1 2 3 4 5 6 7 8 9 0 1 2 3 4 5 6
INCLUDED . X . . . . .
PROTECT . . . . .
PED PRTC . . . . .
NOT OVLP . . . . .
FLSH GRN . 1 . . . . .
LAG X PH . . . . .
LAG 2 PH . . . . .

LAG GRN 0.0 YEL 0.0 RED 0.0 ADV GRN 0.0
    
```

Toggle Once

OVERLAP B

Select TMG VEH OVLP [B] and 'PPLT FYA'

```

TMG VEH OVLP...[B] TYPE: PPLT FYA
PROTECTED LEFT TURN... PHASE 3
OPPOSING THROUGH..... PHASE 4

FLASHING ARROW OUTPUT.....CH10 ISOLATE
DELAY START OF: FYA..0.0 CLEARANCE..0.0
ACTION PLAN SF BIT DISABLE..... 0
    
```

Toggle Once

OVERLAP C

Select TMG VEH OVLP [C] and 'PPLT FYA'

```

TMG VEH OVLP...[C] TYPE: PPLT FYA
PROTECTED LEFT TURN... PHASE 5
OPPOSING THROUGH..... PHASE 6

FLASHING ARROW OUTPUT.....CH11 ISOLATE
DELAY START OF: FYA..0.0 CLEARANCE..0.0
ACTION PLAN SF BIT DISABLE..... 0
    
```

Toggle Once

OVERLAP D

Select TMG VEH OVLP [D] and 'OTHER/ECONOLITE'

```

TMG VEH OVLP...[D] TYPE: OTHER/ECONOLITE
PHASES 1 2 3 4 5 6 7 8 9 0 1 2 3 4 5 6
INCLUDED . . . . . X . . . . .
PROTECT . . . . .
PED PRTC . . . . .
NOT OVLP . . . . .
FLSH GRN . . . . . 1 . . . . .
LAG X PH . . . . .
LAG 2 PH . . . . .

LAG GRN 0.0 YEL 0.0 RED 0.0 ADV GRN 0.0
    
```

END PROGRAMMING

FLASHER CIRCUIT MODIFICATION DETAIL

IN ORDER TO ENSURE THAT SIGNALS FLASH CONCURRENTLY ON THE SAME APPROACH, MAKE THE FOLLOWING FLASHER CIRCUIT CHANGES:

1. ON REAR OF PDA - REMOVE WIRE FROM TERM. T2-4 AND TERMINATE ON T2-2.
2. ON REAR OF PDA - REMOVE WIRE FROM TERM. T2-5 AND TERMINATE ON T2-3.
3. REMOVE FLASHER UNIT 2.

THE CHANGES LISTED ABOVE TIES ALL PHASES AND OVERLAPS TO FLASHER UNIT 1.



12 BROAD STREET
 ASHEVILLE, NORTH CAROLINA 28801
 (828) 254-2201
 FAX (828) 254-4562
 NC LIC. NO. C-1154

THIS ELECTRICAL DETAIL IS FOR
 THE SIGNAL DESIGN: 07-1804
 DESIGNED: November 2017
 SEALED: 6/13/2018
 REVISED: NA

Electrical Detail - Sheet 2 of 2

<p>ELECTRICAL AND PROGRAMMING DETAILS FOR:</p> <p>Prepared for the Offices of:</p> <p>750 N. Greenfield Pkwy, Corner, NC 27529</p>	<p>SR 2433 (Moore Street) at SR 2309 (Rogers Road)</p> <p>Division 7 Alamance County Graham</p> <p>PLAN DATE: November 2017 REVIEWED BY: JB Voso</p> <p>PREPARED BY: SE Wilson REVIEWED BY:</p> <table border="1" style="width: 100%; border-collapse: collapse;"> <thead> <tr> <th>REVISIONS</th> <th>INIT.</th> <th>DATE</th> </tr> </thead> <tbody> <tr> <td> </td> <td> </td> <td> </td> </tr> </tbody> </table>	REVISIONS	INIT.	DATE				<p>DOCUMENT NOT CONSIDERED FINAL UNLESS ALL SIGNATURES COMPLETED</p> <p style="text-align: center;">SEAL</p> <p>James Voso 6/13/2018 DATE</p> <p style="text-align: center;">SIG. INVENTORY NO. 07-1804</p>
REVISIONS	INIT.	DATE						

PHASING DIAGRAM

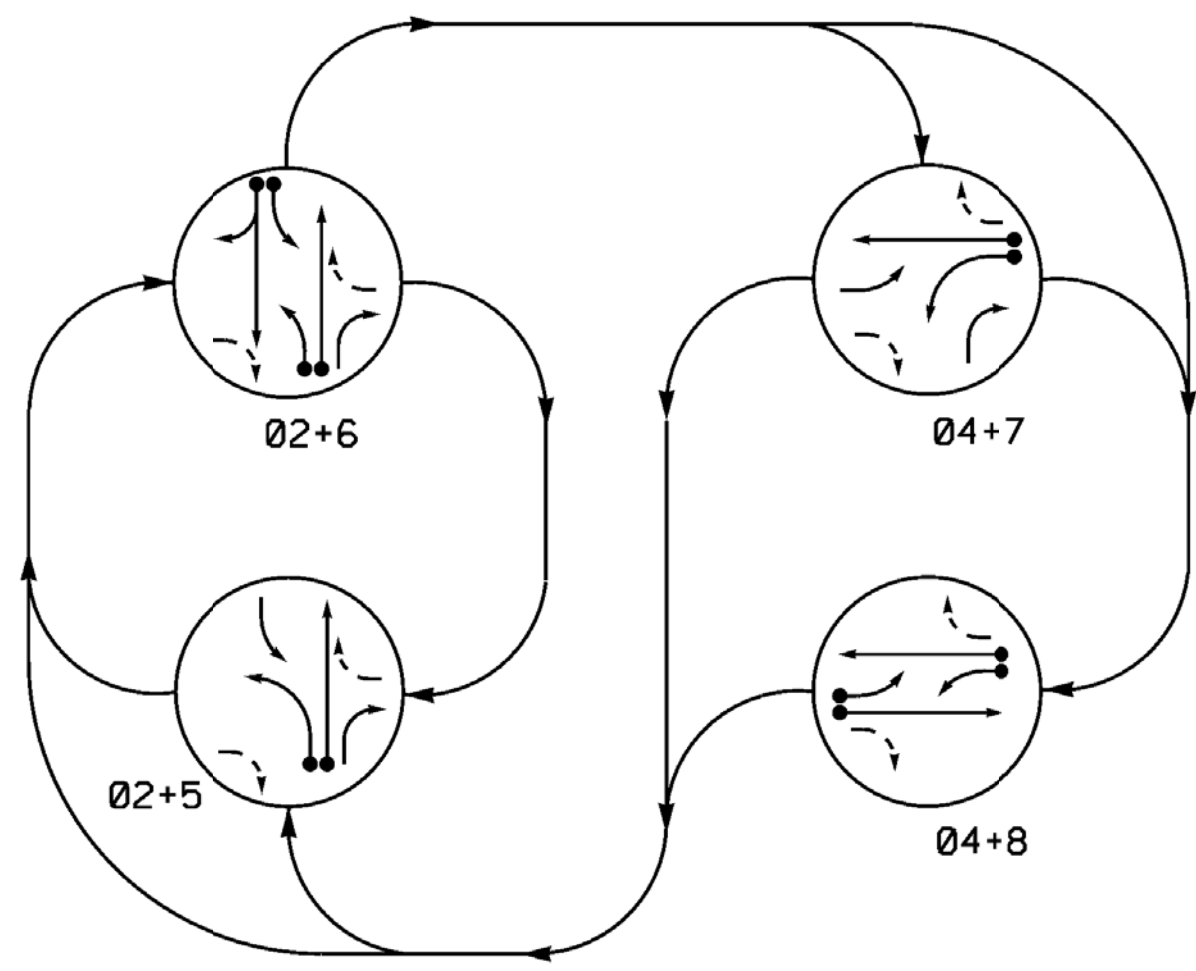

SIGNAL FACE	PHASE				
	0 2 + 5	0 4 + 6	0 4 + 7	0 4 + 8	F L S A H
21, 23	G	G	R	R	Y
22	G	G	R	R	Y
41, 42	R	R	G	G	R
51	-	F	R	R	Y
61, 62	R	G	R	R	Y
63	F	F	R	R	Y
71	R	R	-	F	R
81, 82	R	R	R	G	R
83	R	R	F	F	R

ASC/3 DETECTOR INSTALLATION CHART											
DETECTOR					PROGRAMMING						
LOOP	SIZE (FT)	DISTANCE FROM STOPBAR (FT)	TURNS	NEW LOOP	PHASE	CALLING	EXTEND TIME	DELAY TIME	USE ADDED INITIAL	TYPE	SYSTEM LOOP
2A	6x6	300	EXIST.	-	2	Yes	-	-	X	N	-
4A	6x40	0	2-4-2	-	4	Yes	-	-	-	S	-
5A	6x60	0	2-4-2	-	5	Yes	-	15	-	S	-
6A	6x6	300	EXIST.	-	6	Yes	-	-	X	N	-
6B	6x60	0	2-4-2	-	6	Yes	-	3	-	G	-
7A	6x40	0	2-4-2	-	7	Yes	-	15	-	S	-
8A	6x60	+5	2-4-2	-	8	Yes	-	3	-	S	-
8B	6x40	0	2-4-2	-	8	Yes	-	-	-	S	-

4 Phase Fully Actuated (Burlington-Graham Signal System)

NOTES

1. Refer to "Roadway Standard Drawings NCDOT" dated January 2018 and "Standard Specifications for Roads and Structures" dated January 2018.
2. Do not program signal for late night flashing operation unless otherwise directed by the Engineer.
3. Phase 5 may be lagged.
4. Phase 7 may be lagged.
5. Reposition existing signal heads numbered 42, 81, and 82.
6. Set all detector units to presence mode.
7. In the event of loop replacement, refer to the current ITS and Signals Design Manual and submit a Plan of Record to the Signal Design Section.
8. Locate new cabinet so as not to obstruct sight distance of vehicles turning right on red.
9. Pavement markings are existing.
10. Maximum times shown in timing chart are for free-run operation only. Coordinated signal system timing values supersede these values.
11. Provide minimum of 15' clearance from high point in roadway to bottom of proposed signal heads.

PHASING DIAGRAM DETECTION LEGEND

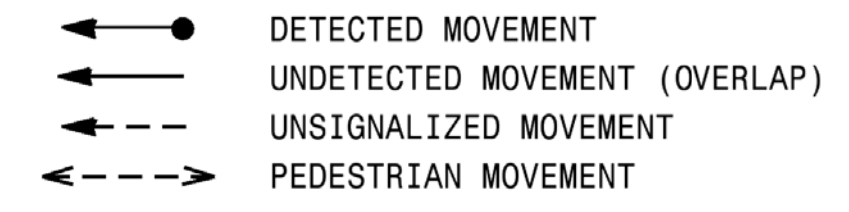

SIGNAL FACE I.D.

All Heads L.E.D.

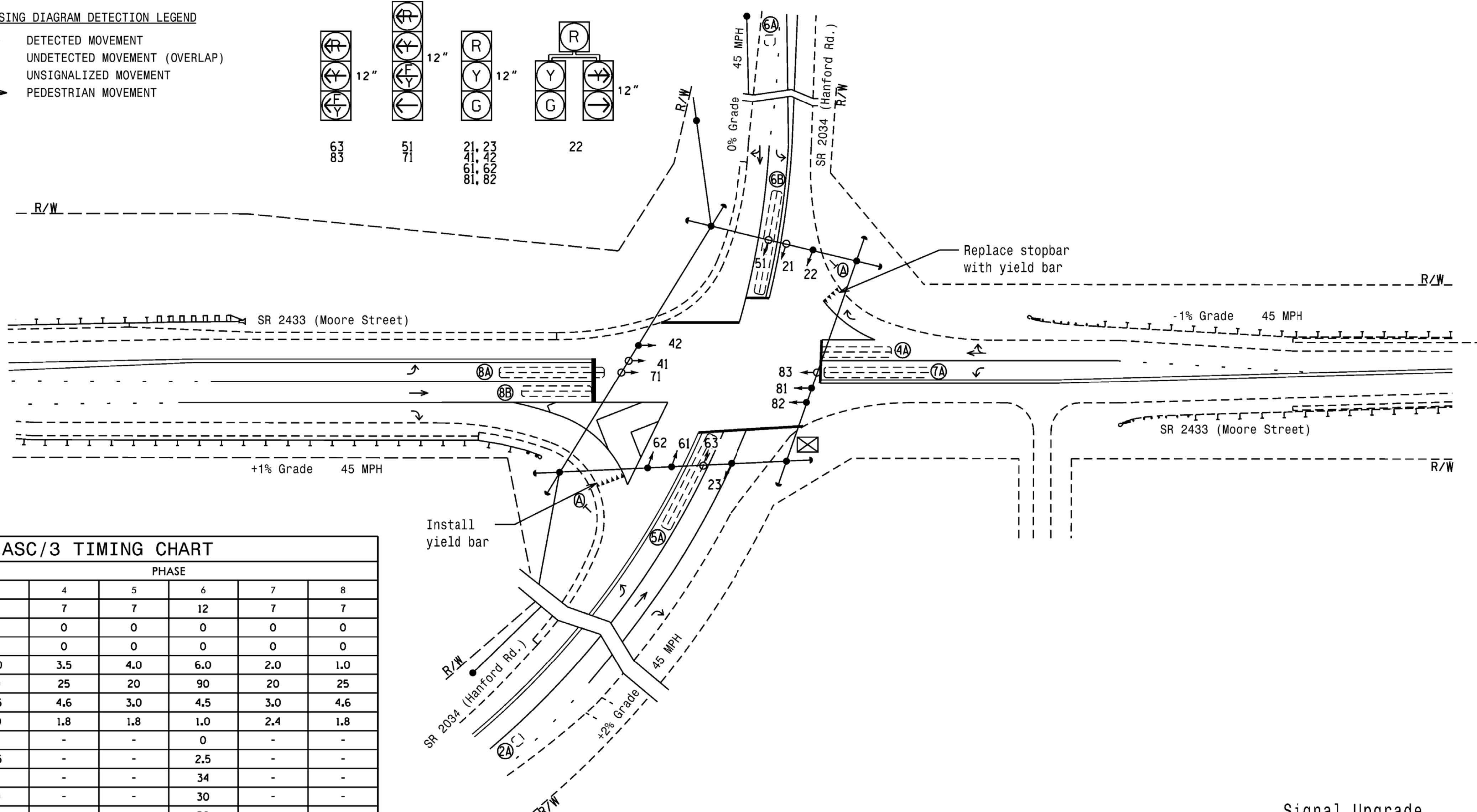
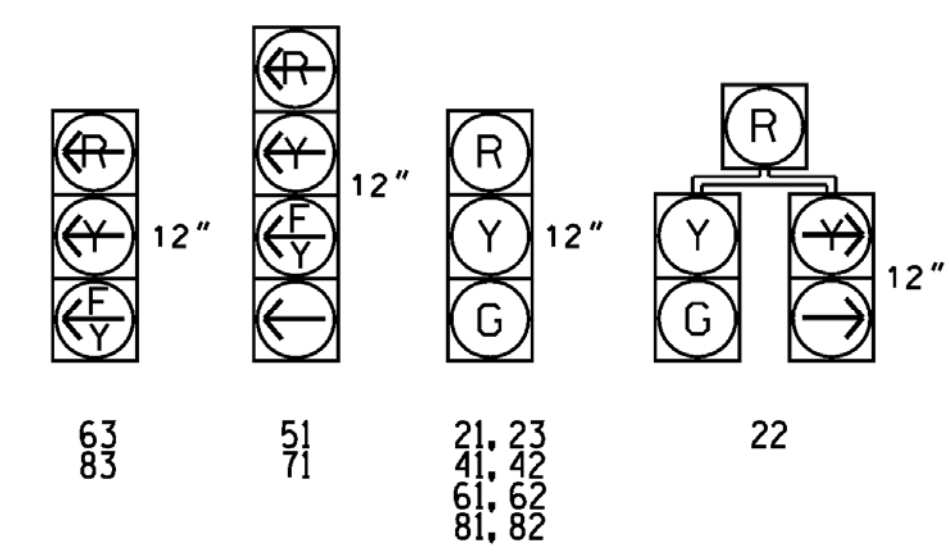

ASC/3 TIMING CHART

FEATURE	PHASE					
	2	4	5	6	7	8
Min Green *	12	7	7	12	7	7
Walk *	0	0	0	0	0	0
Ped Clear	0	0	0	0	0	0
Veh. Extension *	6.0	3.5	4.0	6.0	2.0	1.0
Max I *	90	25	20	90	20	25
Yellow	4.5	4.6	3.0	4.5	3.0	4.6
Red Clear	1.0	1.8	1.8	1.0	2.4	1.8
Actuations B4 Add *	0	-	-	0	-	-
Seconds / Actuation *	2.5	-	-	2.5	-	-
Max Initial *	34	-	-	34	-	-
Time Before Reduction *	30	-	-	30	-	-
Time To Reduce *	30	-	-	30	-	-
Minimum Gap	3.0	-	-	3.0	-	-
Locking Detector	X	-	-	X	-	-
Recall Position	VEH. RECALL	-	-	VEH. RECALL	-	-
Dual Entry	-	X	-	-	-	X
Simultaneous Gap	X	X	X	X	X	X

* These values may be field adjusted. Do not adjust Min Green and Extension times for phases 2 and 6 lower than what is shown. Min Green for all other phases should not be lower than 4 seconds.

LEGEND

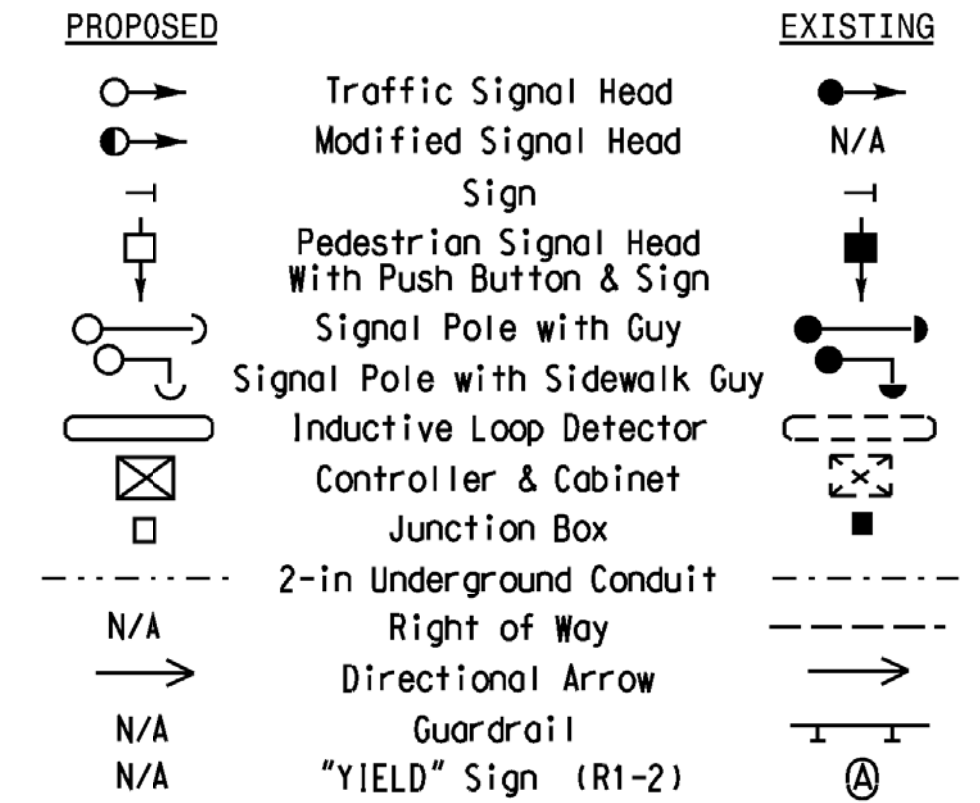

Mattern & Craig
ENGINEERS • SURVEYORS

12 BROAD STREET
ASHEVILLE, NORTH CAROLINA 28801
(828) 254-2201
FAX (828) 254-4562
NC LIC. NO. C-1154

Signal Upgrade

Prepared for the Offices of:

 SR 2304 (Hanford Road) at SR 2433 (Moore Street)
 Division 7 Alamance County Graham
 PLAN DATE: November 2017 REVIEWED BY: JB Voso
 PREPARED BY: SE Wilson REVIEWED BY:
 SCALE 1"=40'
 DOCUMENT NOT CONSIDERED FINAL UNLESS ALL SIGNATURES COMPLETED

 6/13/2018
 SIG. INVENTORY NO. 07-1805

*****SYSTEM*****
 *****USER*****

EDI MODEL 2018ECLIP-NC CONFLICT MONITOR PROGRAMMING DETAIL
(remove jumpers and set switches as shown)

REMOVE DIODE JUMPERS 2-5, 2-6, 2-9, 2-11, 4-7, 4-8, 4-10, 4-12, 5-9, 5-11, 6-9
6-11, 7-10, 7-12, 8-10, 8-12, 9-11, and 10-12.

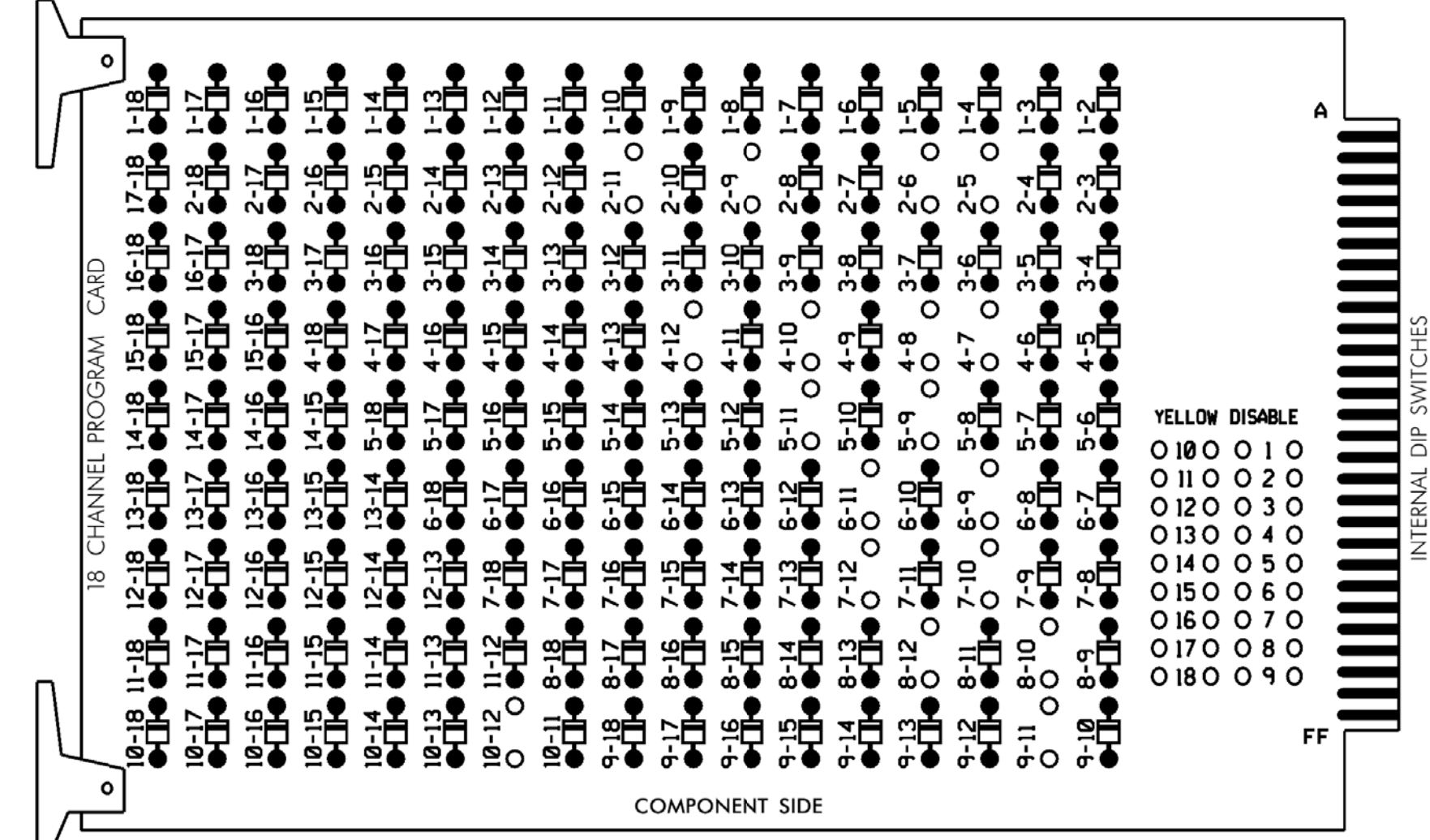

- NOTES:
- Card is provided with all diode jumpers in place. Removal of any jumper allows its channels to run concurrently.
 - Ensure jumpers SEL2-SEL5 and SEL9 are present on the monitor board.
 - Ensure that Red Enable is active at all times during normal operation.
 - Integrate monitor with Ethernet network in cabinet.

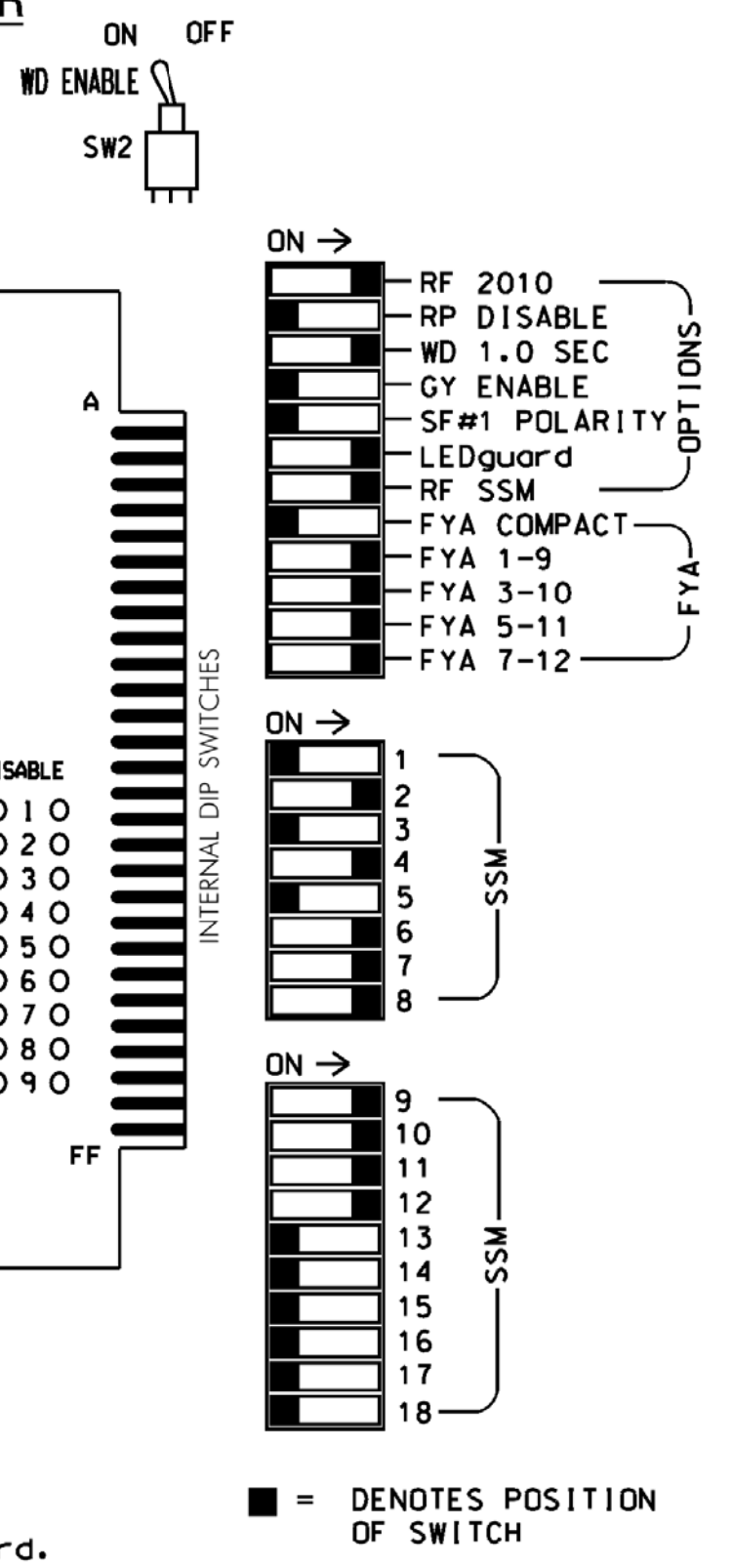

NOTES

- To prevent "flash-conflict" problems, insert red flash program blocks for all unused vehicle load switches in the output file. The installer shall verify that signal heads flash in accordance with the Signal Plans.
- Program phases 4 and 8 for Dual Entry.
- Program controller to start up in phase 2 Green and 6 Green.
- The cabinet and controller are part of the Burlington-Graham Signal System.

EQUIPMENT INFORMATION

CONTROLLER.....2070LX
 CABINET.....332 W/ AUX
 SOFTWARE.....ECONOLITE ASC/3-2070
 CABINET MOUNT.....BASE
 OUTPUT FILE POSITIONS...18 WITH AUX FILE
 LOAD SWITCHES USED.....S2,S5,S7,S8,S10,S11,
 AUX S1,AUX S2,AUX S4,AUX S5
 PHASES USED.....2,4,5,6,7,8
 OVERLAP A.....*
 OVERLAP B.....*
 OVERLAP D.....*
 OVERLAP A.....*

* See overlap programming detail on sheet 2

SIGNAL HEAD HOOK-UP CHART

LOAD SWITCH NO.	S1	S2	S3	S4	S5	S6	S7	S8	S9	S10	S11	S12	AUX S1	AUX S2	AUX S3	AUX S4	AUX S5	AUX S6	
CHU CHANNEL NO.	1	2	13	3	4	14	5	6	15	7	8	16	9	10	17	11	12	18	
PHASE	1	2	2 PED	3	4	4 PED	5	6	6 PED	7	8	8 PED	OLA	OLB	SPARE	OLC	OLD	SPARE	
SIGNAL HEAD NO.	NU	21,22,23	NU	NU	41,42	NU	51	61,62	NU	71	22	81,82	NU	63	83	NU	51	71	NU
RED		128			101			134		*		107							
YELLOW		129			102		*	135				108							
GREEN		130			103			136				109							
RED ARROW																A121	A124	A114	A101
YELLOW ARROW											123					A122	A125	A115	A102
FLASHING YELLOW ARROW																A123	A126	A116	A103
GREEN ARROW								133		124	124								

NU = Not Used
 * Denotes install load resistor. See load resistor installation detail this sheet.
 * See pictorial of head wiring in detail below.

INPUT FILE POSITION LAYOUT
(front view)

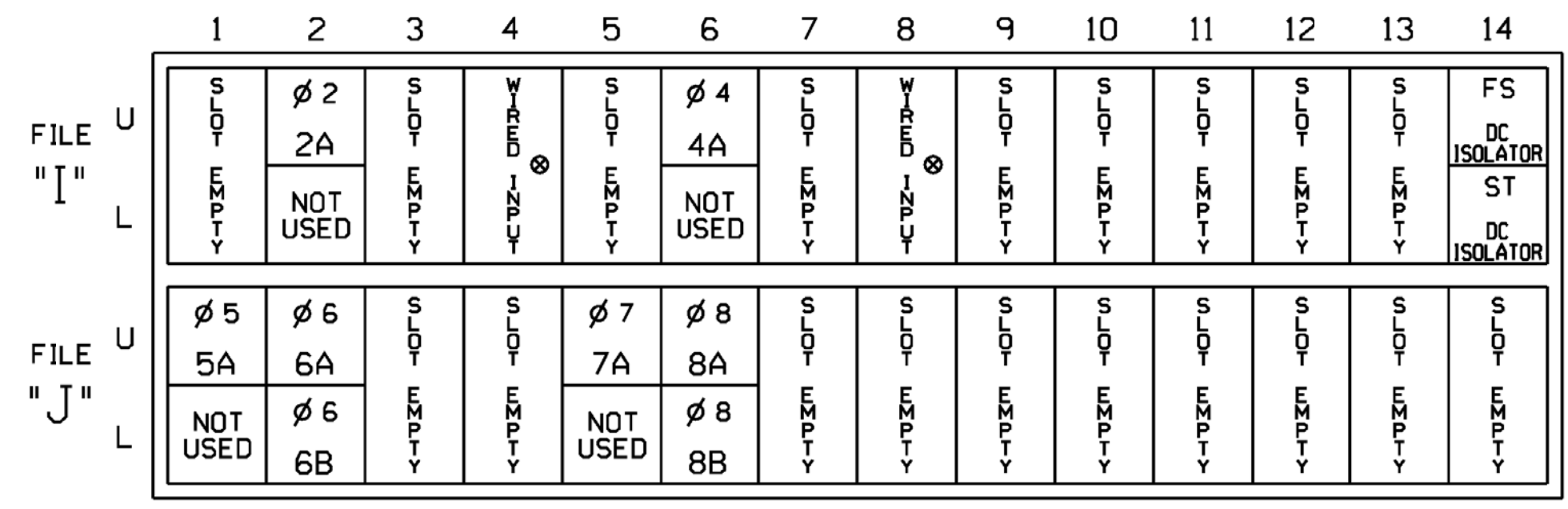

EX.: 1A, 2A, ETC. = LOOP NO.'S
 FS = FLASH SENSE
 ST = STOP TIME
 * Wired Input - Do not populate slot with detector card

INPUT FILE CONNECTION & PROGRAMMING CHART

LOOP NO.	LOOP TERMINAL	INPUT FILE POS.	PIN NO.	DETECTOR NO.	NEMA PHASE	CALL	EXTEND TIME	DELAY TIME	ADDED INITIAL	DETECTOR TYPE
2A	TB2-5,6	I2U	39	2	2	YES			X	N
4A	TB4-9,10	I6U	41	4	4	YES				S
5A ¹	TB3-1,2	J1U	55	5	5	YES		15		S
	-	I4U	47	22	2	YES		3		G
6A	TB3-5,6	J2U	40	6	6	YES			X	N
6B	TB3-7,8	J2L	44	16	6	YES		3		G
7A ²	TB5-5,6	J5U	57	7	7	YES		15		S
	-	I8U	49	24	4	YES				S
8A	TB5-9,10	J6U	42	8	8	YES		3		S
8B	TB5-11,12	J6L	46	18	8	YES				S

¹Add jumper from J1-W to I4-W, on rear of input file.
²Add jumper from J5-W to I8-W, on rear of input file.

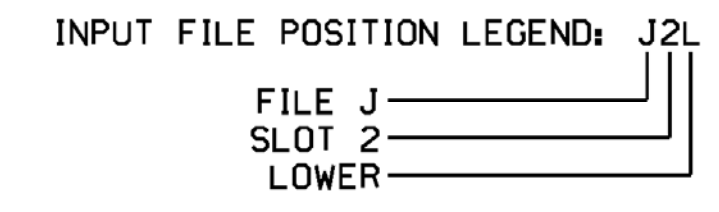

FYA SIGNAL WIRING DETAIL
(wire signal heads as shown)

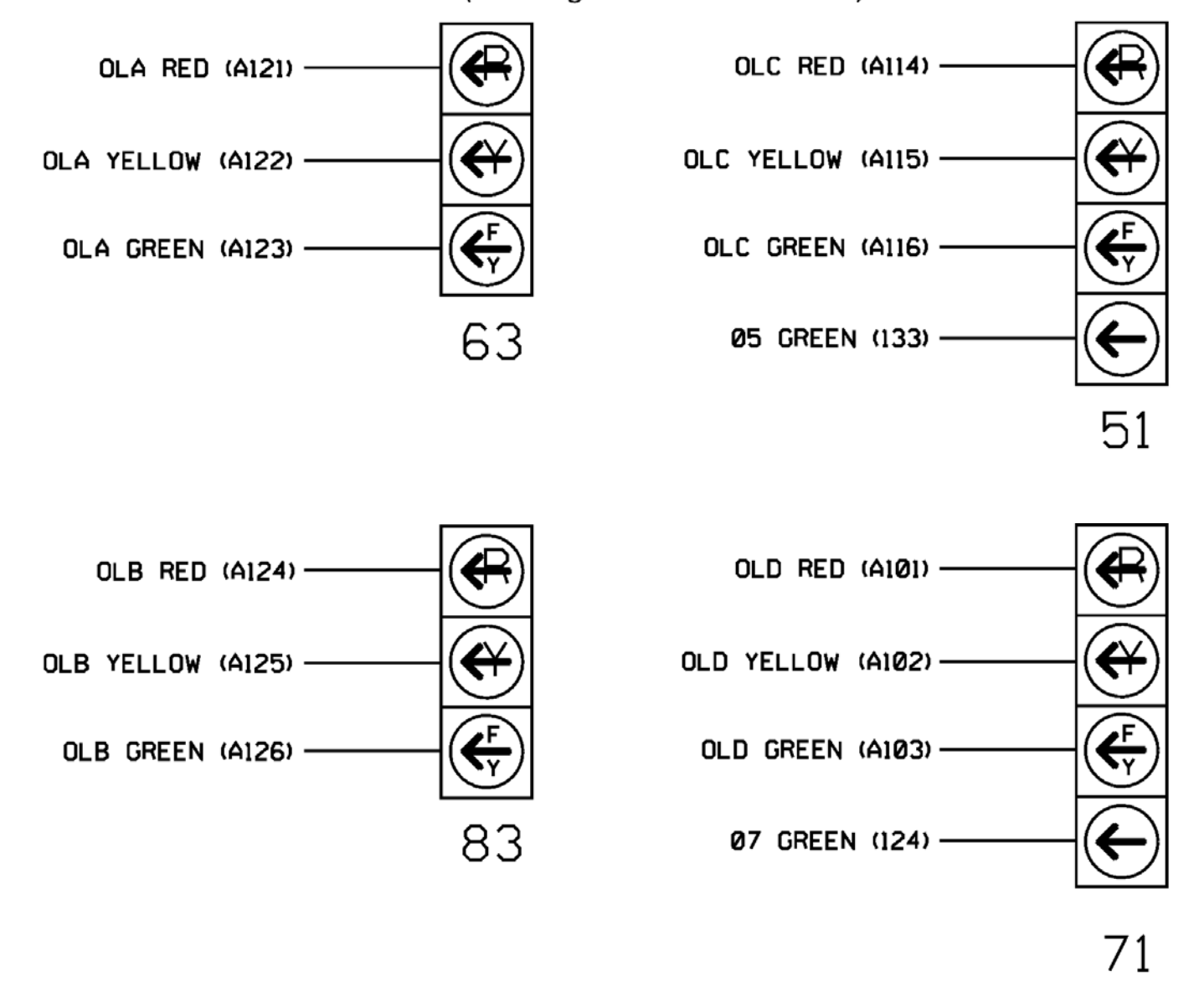

LOAD RESISTOR INSTALLATION DETAIL
(install resistors as shown)

VALUE (ohms)	WATTAGE
1.5K - 1.9K	25W (min)
2.0K - 3.0K	10W (min)

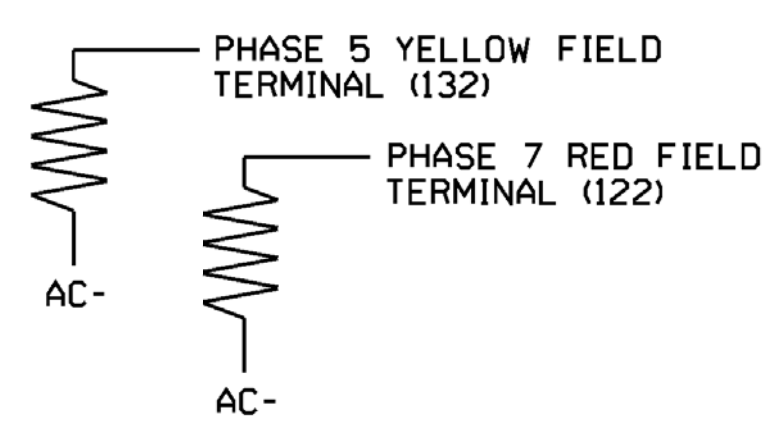

Electrical Detail - Sheet 1 of 2

DOCUMENT NOT CONSIDERED FINAL UNLESS ALL SIGNATURES COMPLETED

Electrical and Programming Details For: SR 2304 (Hanford Road) at SR 2433 (Moore Street)

Prepared for the Offices of: **Mattern & Craig ENGINEERS • SURVEYORS**

12 BROAD STREET ASHEVILLE, NORTH CAROLINA 28801 (828) 254-2201 FAX (828) 254-4562 NC LIC. NO. C-1154

Division 7 Alamance County Graham
 PLAN DATE: November 2017 REVIEWED BY: JB Voso
 PREPARED BY: SE Wilson REVIEWED BY:

REVISIONS: INIT. DATE

James Voso 6/13/2018
 SEAL 022599
 SIG. INVENTORY NO. 07-1805

*****SYTIME*****
 *****D*****
 *****USER*****

ECONOLITE ASC/3-2070 OVERLAP PROGRAMMING DETAIL

(program controller as shown)

1. From Main Menu select 2. CONTROLLER
2. From CONTROLLER Submenu select 2. VEHICLE OVERLAPS

OVERLAP A

Select TMG VEH OVLP [A] and 'OTHER/ECONOLITE'

TMG VEH OVLP... [A] TYPE:	OTHER/ECONOLITE
PHASES	1 2 3 4 5 6 7 8 9 0 1 2 3 4 5 6
INCLUDED	. X
PROTECT
PED PRTC
NOT OVLP
FLSH GRN	. 1
LAG X PH
LAG 2 PH
LAG GRN	0.0 YEL 0.0 RED 0.0 ADV GRN 0.0

Toggle Once

OVERLAP B

Select TMG VEH OVLP [B] and 'OTHER/ECONOLITE'

TMG VEH OVLP... [B] TYPE:	OTHER/ECONOLITE
PHASES	1 2 3 4 5 6 7 8 9 0 1 2 3 4 5 6
INCLUDED	. . . X
PROTECT
PED PRTC
NOT OVLP
FLSH GRN	. . . 1
LAG X PH
LAG 2 PH
LAG GRN	0.0 YEL 0.0 RED 0.0 ADV GRN 0.0

Toggle Once

OVERLAP C

Select TMG VEH OVLP [C] and 'PPLT FYA'

TMG VEH OVLP... [C] TYPE:	PPLT FYA
PROTECTED LEFT TURN....	PHASE 5
OPPOSING THROUGH.....	PHASE 6
FLASHING ARROW OUTPUT.....	CH11 ISOLATE
DELAY START OF: FYA..0.0	CLEARANCE..0.0
ACTION PLAN SF BIT DISABLE.....	0

Toggle Once

OVERLAP D

Select TMG VEH OVLP [D] and 'PPLT FYA'

TMG VEH OVLP... [D] TYPE:	PPLT FYA
PROTECTED LEFT TURN....	PHASE 7
OPPOSING THROUGH.....	PHASE 8
FLASHING ARROW OUTPUT.....	CH12 ISOLATE
DELAY START OF: FYA..0.0	CLEARANCE..0.0
ACTION PLAN SF BIT DISABLE.....	0

END PROGRAMMING

FLASHER CIRCUIT MODIFICATION DETAIL

IN ORDER TO ENSURE THAT SIGNALS FLASH CONCURRENTLY ON THE SAME APPROACH, MAKE THE FOLLOWING FLASHER CIRCUIT CHANGES:

1. ON REAR OF PDA - REMOVE WIRE FROM TERM. T2-4 AND TERMINATE ON T2-2.
2. ON REAR OF PDA - REMOVE WIRE FROM TERM. T2-5 AND TERMINATE ON T2-3.
3. REMOVE FLASHER UNIT 2.

THE CHANGES LISTED ABOVE TIES ALL PHASES AND OVERLAPS TO FLASHER UNIT 1.



Mattern & Craig
ENGINEERS • SURVEYORS

12 BROAD STREET
ASHEVILLE, NORTH CAROLINA 28801
(828) 254-2201
FAX (828) 254-4562
NC LIC. NO. C-1154

THIS ELECTRICAL DETAIL IS FOR THE SIGNAL DESIGN: 07-1805
DESIGNED: November 2017
SEALED: 6/13/2018
REVISED: NA

Electrical Detail - Sheet 2 of 2

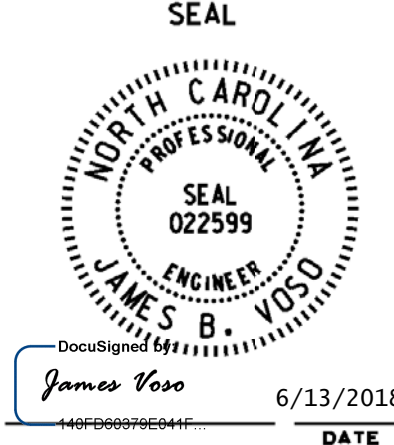
 <small>750 N. Greenfield Pkwy, Garner, NC 27529</small>	<p>SR 2304 (Hanford Road) at SR 2433 (Moore Street)</p>	<p>SEAL</p>  <small>SEAL 022599</small> JAMES B. VOSO <small>ENGINEER</small>								
	<p>Division 7 Alamance County Graham</p> <p>PLAN DATE: November 2017 REVIEWED BY: JB Voso</p> <p>PREPARED BY: SE Wilson REVIEWED BY:</p>	<table border="1" style="width: 100%; border-collapse: collapse;"> <thead> <tr> <th>REVISIONS</th> <th>INIT.</th> <th>DATE</th> </tr> </thead> <tbody> <tr> <td> </td> <td> </td> <td> </td> </tr> <tr> <td> </td> <td> </td> <td> </td> </tr> </tbody> </table>	REVISIONS	INIT.	DATE					
REVISIONS	INIT.	DATE								

James Voso 6/13/2018
DATE

SIG. INVENTORY NO. 07-1805

 SYSTEM TIME *****

 USER NAME *****

DEFAULT PHASING DIAGRAM

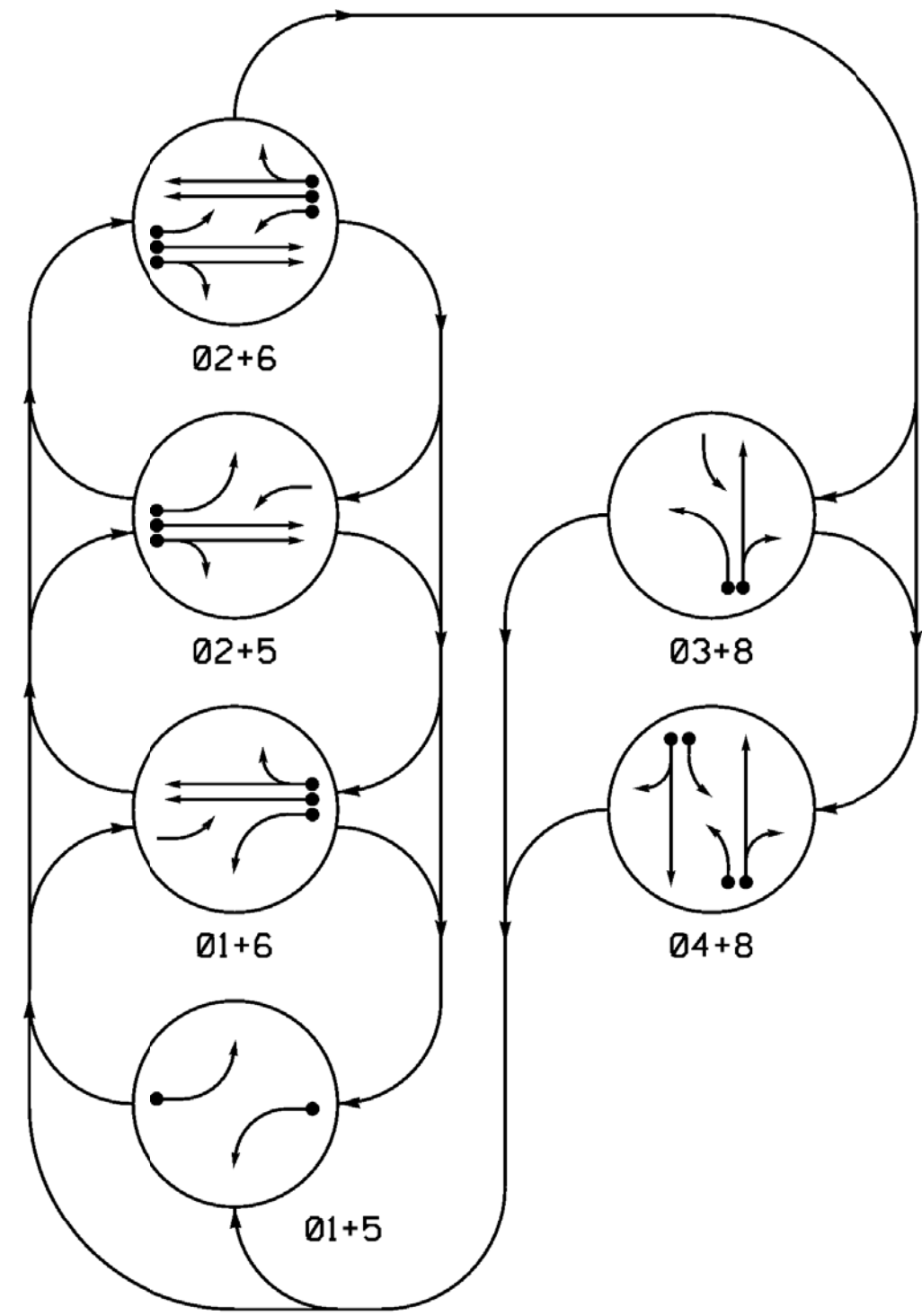

DEFAULT TABLE OF OPERATION

SIGNAL FACE	PHASE						
	01+5	02+5	02+6	03+8	04+8	FLASH	
11	-	-	F	F	R	R	Y
21, 22	R	R	G	G	R	R	Y
31	R	R	R	R	-	F	R
41	R	R	R	R	F	F	R
42, 43	R	R	R	R	R	G	R
51	-	F	-	F	R	R	Y
61, 62, 63	R	G	R	G	R	R	Y
81, 82	R	R	R	R	G	G	R

SIGNAL FACE I.D.

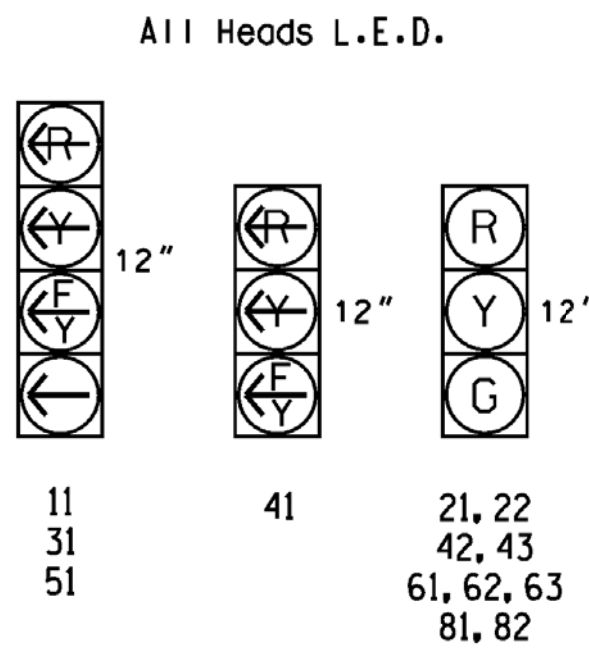

ALTERNATE PHASING DIAGRAM

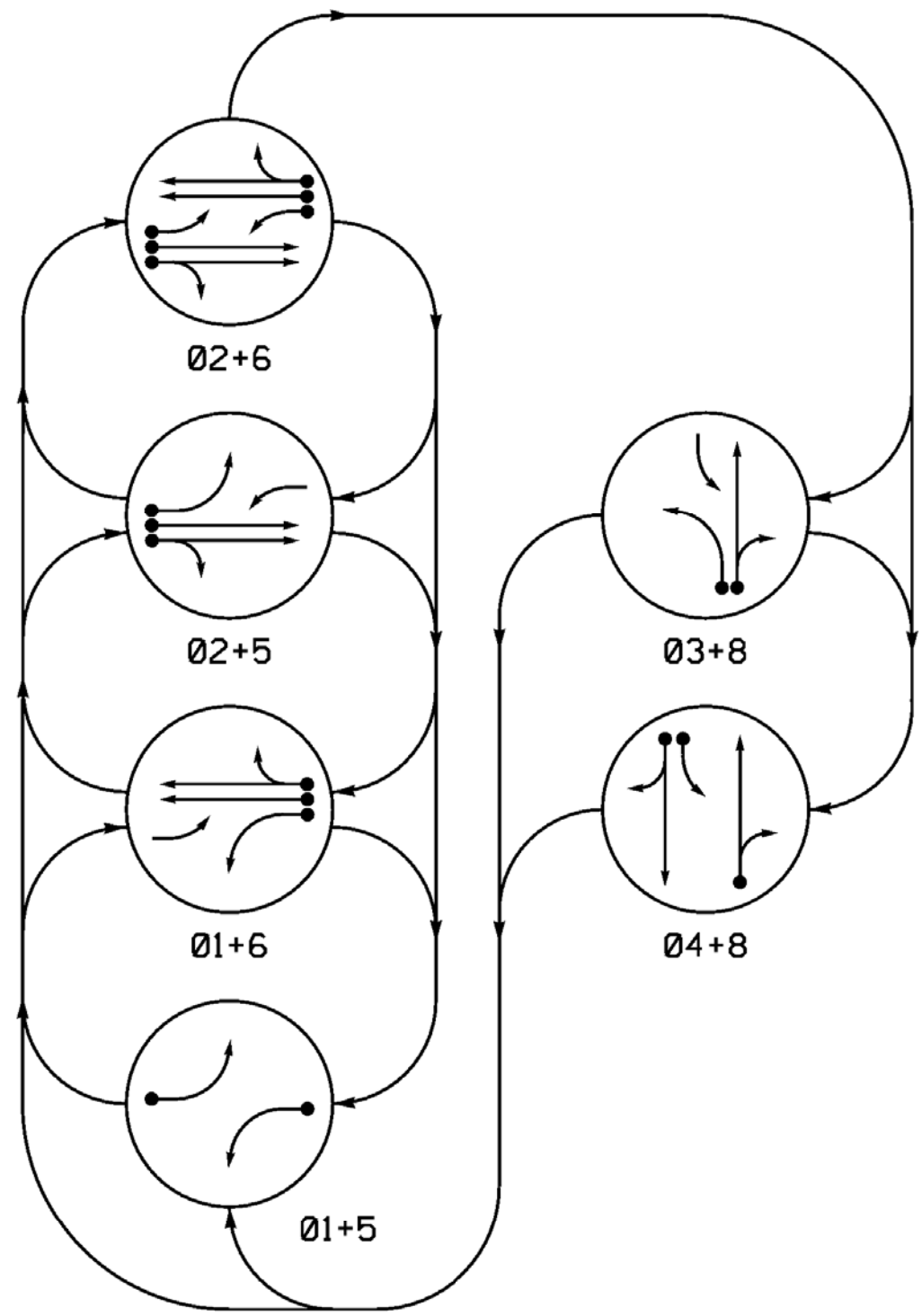

ALTERNATE TABLE OF OPERATION

SIGNAL FACE	PHASE						
	01+5	02+5	02+6	03+8	04+8	FLASH	
11	-	-	F	F	R	R	Y
21, 22	R	R	G	G	R	R	Y
31	R	R	R	R	-	R	R
41	R	R	R	R	F	F	R
42, 43	R	R	R	R	R	G	R
51	-	F	-	F	R	R	Y
61, 62, 63	R	G	R	G	R	R	Y
81, 82	R	R	R	R	G	G	R

6 Phase Fully Actuated (Burlington-Graham Signal System)

NOTES

1. Refer to "Roadway Standard Drawings NCDOT" dated January 2018 and "Standard Specifications for Roads and Structures" dated January 2018.
2. Do not program signal for late night flashing operation unless otherwise directed by the Engineer.
3. Phase 1 and/or phase 5 may be lagged.
4. Phase 3 may be lagged.
5. Reposition existing signal heads numbered 21, 42, 43, 61, 81, and 82.
6. Set all detector units to presence mode.
7. In the event of loop replacement, refer to the current ITS and Signals Design Manual and submit a Plan of Record to the Signal Design Section.
8. Locate new cabinet so as not to obstruct sight distance of vehicles turning right on red.
9. Pavement markings are existing.
10. The City Traffic Engineer will determine the hours of use for each phasing plan.
11. Maximum times shown in timing chart are for free-run operation only. Coordinated signal system timing values supersede these values.

PHASING DIAGRAM DETECTION LEGEND

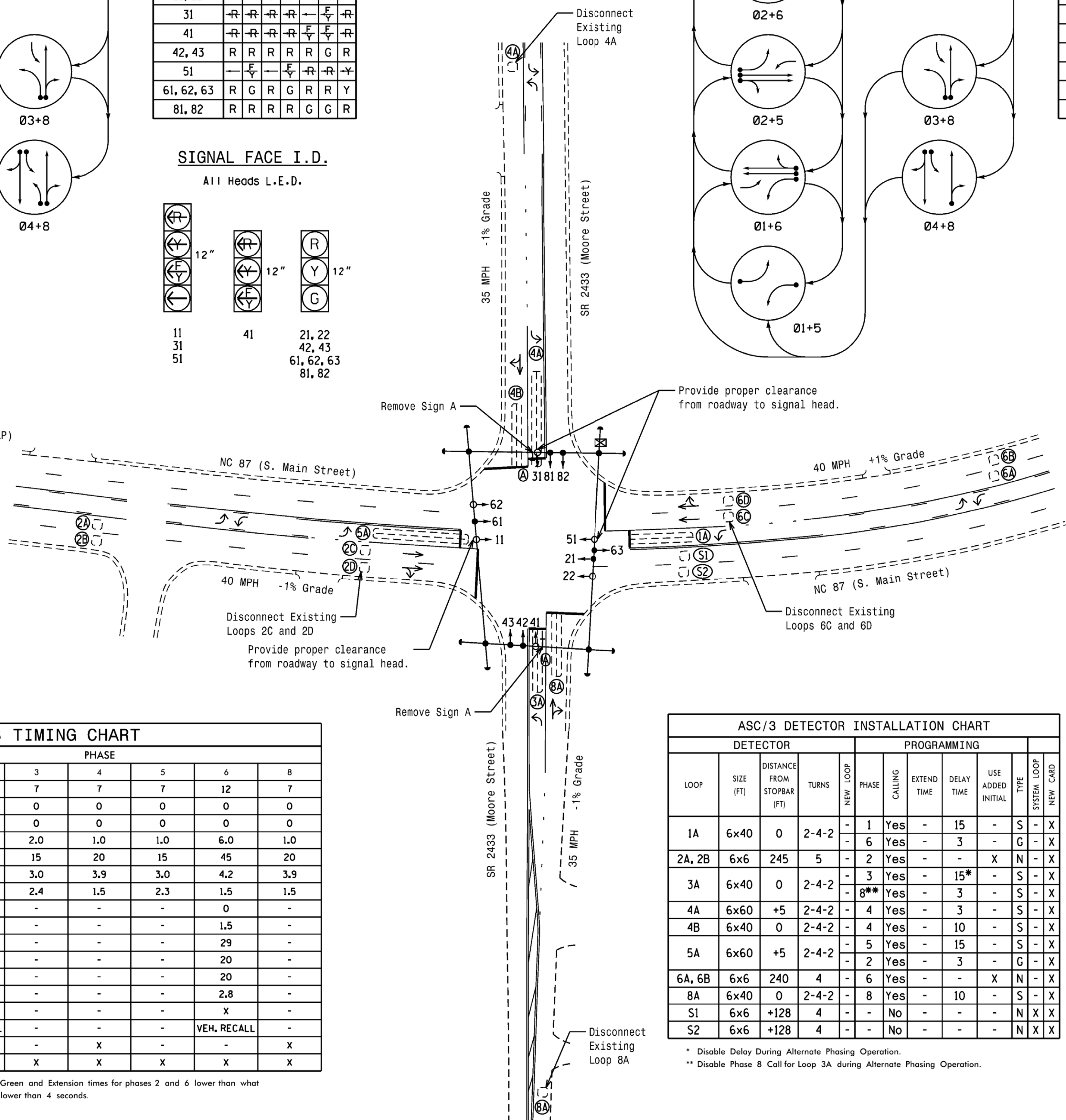
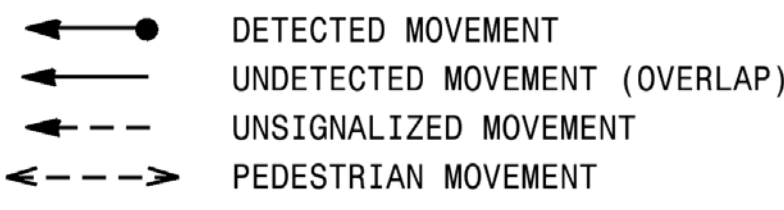

ASC/3 TIMING CHART

FEATURE	PHASE							
	1	2	3	4	5	6	7	8
Min Green *	7	12	7	7	7	12	7	7
Walk *	0	0	0	0	0	0	0	0
Ped Clear	0	0	0	0	0	0	0	0
Veh. Extension *	2.0	6.0	2.0	1.0	1.0	6.0	1.0	1.0
Max 1 *	15	45	15	20	15	45	20	20
Yellow	3.0	4.2	3.0	3.9	3.0	4.2	3.9	3.9
Red Clear	2.6	1.5	2.4	1.5	2.3	1.5	1.5	1.5
Actuations B4 Add *	-	0	-	-	-	0	-	-
Seconds / Actuation *	-	1.5	-	-	-	1.5	-	-
Max Initial *	-	29	-	-	-	29	-	-
Time Before Reduction *	-	20	-	-	-	20	-	-
Time To Reduce *	-	20	-	-	-	20	-	-
Minimum Gap	-	2.8	-	-	-	2.8	-	-
Locking Detector	-	X	-	-	-	X	-	-
Recall Position	-	VEH. RECALL	-	-	-	VEH. RECALL	-	-
Dual Entry	-	-	-	X	-	-	-	X
Simultaneous Gap	X	X	X	X	X	X	X	X

ASC/3 DETECTOR INSTALLATION CHART

LOOP	SIZE (FT)	DISTANCE FROM STOPBAR (FT)	TURNS	NEW LOOP	PROGRAMMING							
					PHASE	CALLING	EXTEND TIME	DELAY TIME	USE ADDED INITIAL	TYPE	SYSTEM LOOP	NEW CARD
1A	6x40	0	2-4-2	-	1	Yes	-	15	-	S	-	X
2A, 2B	6x6	245	5	-	6	Yes	-	3	-	G	-	X
3A	6x40	0	2-4-2	-	3	Yes	-	15*	-	S	-	X
4A	6x60	+5	2-4-2	-	4	Yes	-	3	-	S	-	X
4B	6x40	0	2-4-2	-	4	Yes	-	10	-	S	-	X
5A	6x60	+5	2-4-2	-	5	Yes	-	15	-	S	-	X
6A, 6B	6x6	240	4	-	6	Yes	-	-	-	X	N	X
8A	6x40	0	2-4-2	-	8	Yes	-	10	-	S	-	X
S1	6x6	+128	4	-	-	No	-	-	-	N	X	X
S2	6x6	+128	4	-	-	No	-	-	-	N	X	X

* These values may be field adjusted. Do not adjust Min Green and Extension times for phases 2 and 6 lower than what is shown. Min Green for all other phases should not be lower than 4 seconds.

* Disable Delay During Alternate Phasing Operation.
** Disable Phase 8 Call for Loop 3A during Alternate Phasing Operation.

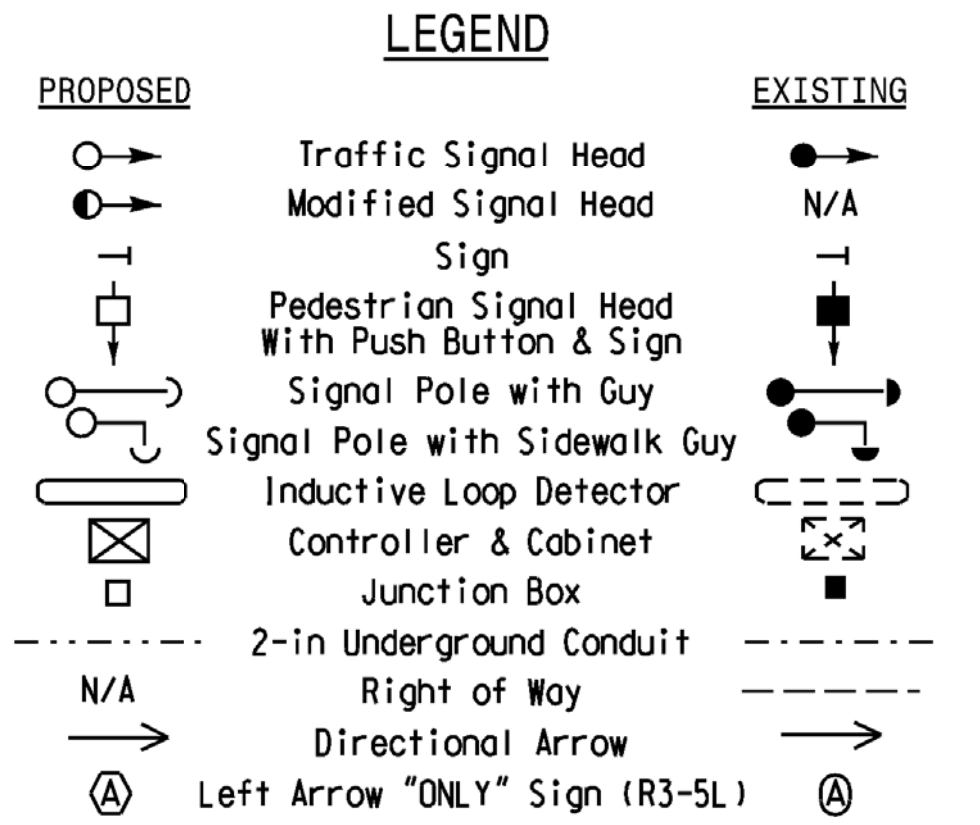

12 BROAD STREET
ASHEVILLE, NORTH CAROLINA 28801
(828) 254-2201
FAX (828) 254-4562
NC LIC. NO. C-1154

Signal Upgrade

DOCUMENT NOT CONSIDERED FINAL UNLESS ALL SIGNATURES COMPLETED

	Prepared for the Offices of: NC 87 (S. Main Street) at SR 2433 (Moore Street)		SEAL
	Division 7 Alamance County Graham	PREPARED BY: SE Greene REVIEWED BY: JB Voso	
SCALE 0 40 1"=40'	REVISIONS INIT. DATE	REVISIONS INIT. DATE	SIG. INVENTORY NO. 07-1806

EDI MODEL 2018ECLIP-NC CONFLICT MONITOR PROGRAMMING DETAIL

(remove jumpers and set switches as shown)

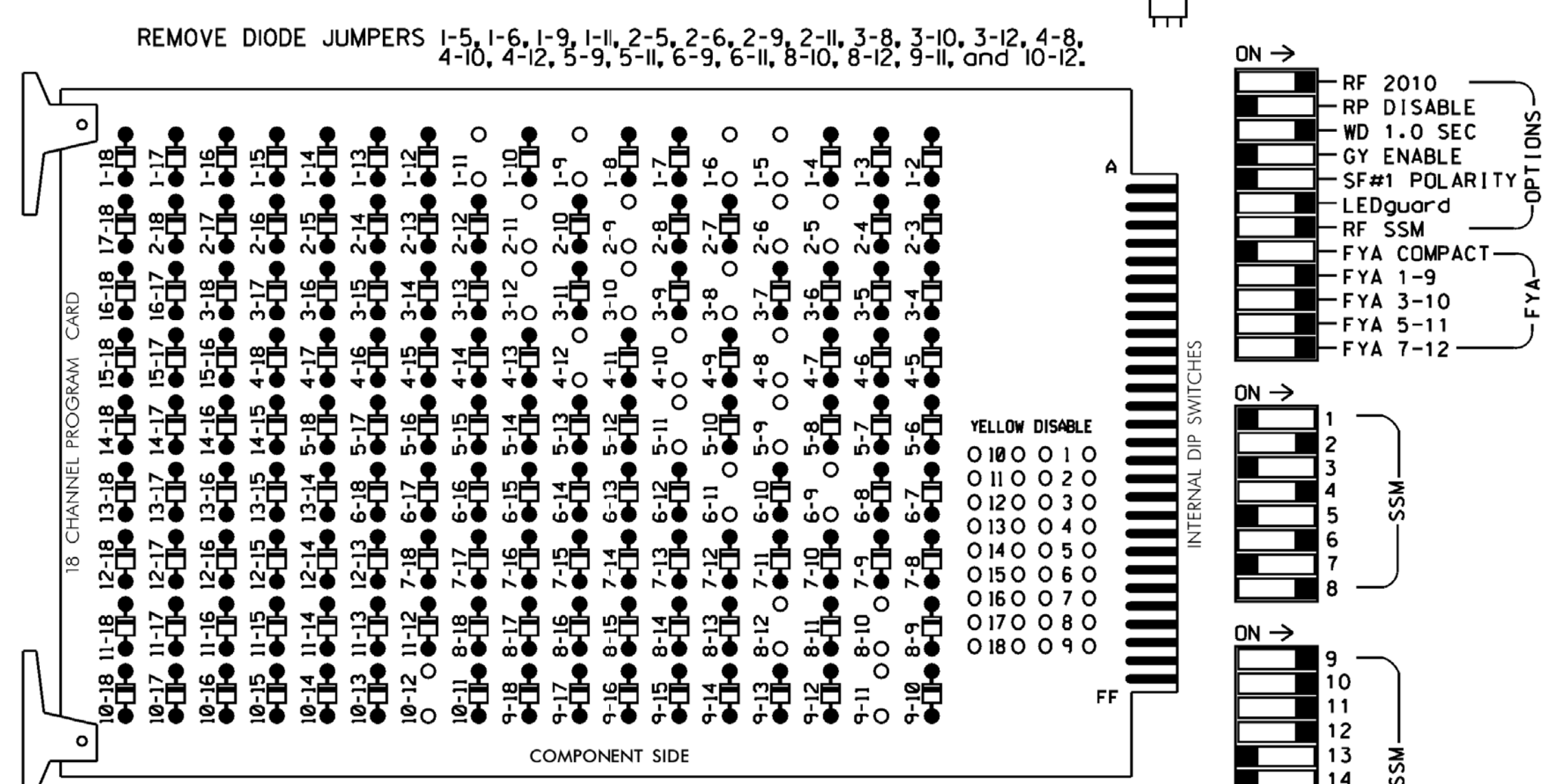

REMOVE DIODE JUMPERS 1-5, 1-6, 1-9, 1-11, 2-5, 2-6, 2-9, 2-11, 3-8, 3-10, 3-12, 4-8, 4-10, 4-12, 5-9, 5-11, 6-9, 6-11, 8-10, 8-12, 9-11, and 10-12.

REMOVE JUMPERS AS SHOWN

NOTES:

- Card is provided with all diode jumpers in place. Removal of any jumper allows its channels to run concurrently.
- Ensure jumpers SEL2-SEL5 and SEL9 are present on the monitor board.
- Ensure that Red Enable is active at all times during normal operation.
- Integrate monitor with Ethernet network in cabinet.

■ = DENOTES POSITION OF SWITCH

NOTES

- To prevent "flash-conflict" problems, insert red flash program blocks for all unused vehicle load switches in the output file. The installer shall verify that signal heads flash in accordance with the Signal Plans.
- Program phases 4 and 8 for Dual Entry.
- Program controller to start up in phase 2 Green and 6 Green.
- The cabinet and controller are part of the Burlington-Graham Signal System.

EQUIPMENT INFORMATION

CONTROLLER.....2070LX
 CABINET.....332 W/AUX
 SOFTWARE.....ECONOLITE ASC/3-2070
 CABINET MOUNT.....BASE
 OUTPUT FILE POSITIONS...18 WITH AUX. OUTPUT FILE
 LOAD SWITCHES USED.....S1,S2,S4,S5,S7,S8,S11,
 AUX S1,AUX S2,AUX S4,AUX S5
 PHASES USED.....1,2,3,4,5,6,8
 OVERLAP "A".....*
 OVERLAP "B".....*
 OVERLAP "C".....*
 OVERLAP "D".....*

* See overlap programming detail on sheet 2

SIGNAL HEAD HOOK-UP CHART

LOAD SWITCH NO.	S1	S2	S3	S4	S5	S6	S7	S8	S9	S10	S11	S12	AUX S1	AUX S2	AUX S3	AUX S4	AUX S5	AUX S6
CMU CHANNEL NO.	1	2	13	3	4	14	5	6	15	7	8	16	9	10	17	11	12	18
P-HASE	1	2	2 PED	3	4	4 PED	5	6	6 PED	7	8	8 PED	OLA	OLB	SPARE	OLC	OLD	SPARE
SIGNAL HEAD NO.	11	21,22	NU	31	42,43	NU	51	61,62,63	NU	NU	81,82	NU	11	31	NU	51	41	NU
RED		128			101			134			107							
YELLOW	*	129		*	102		*	135			108							
GREEN		130			103			136			109							
RED ARROW													A121	A124		A114	A101	
YELLOW ARROW														A122	A125		A115	A102
FLASHING YELLOW ARROW														A123	A126		A116	A103
GREEN ARROW	127				118			133										

NU = Not Used

* Denotes install load resistor. See load resistor installation detail this sheet.

* See pictorial of head wiring in detail this sheet.

INPUT FILE POSITION LAYOUT

(front view)

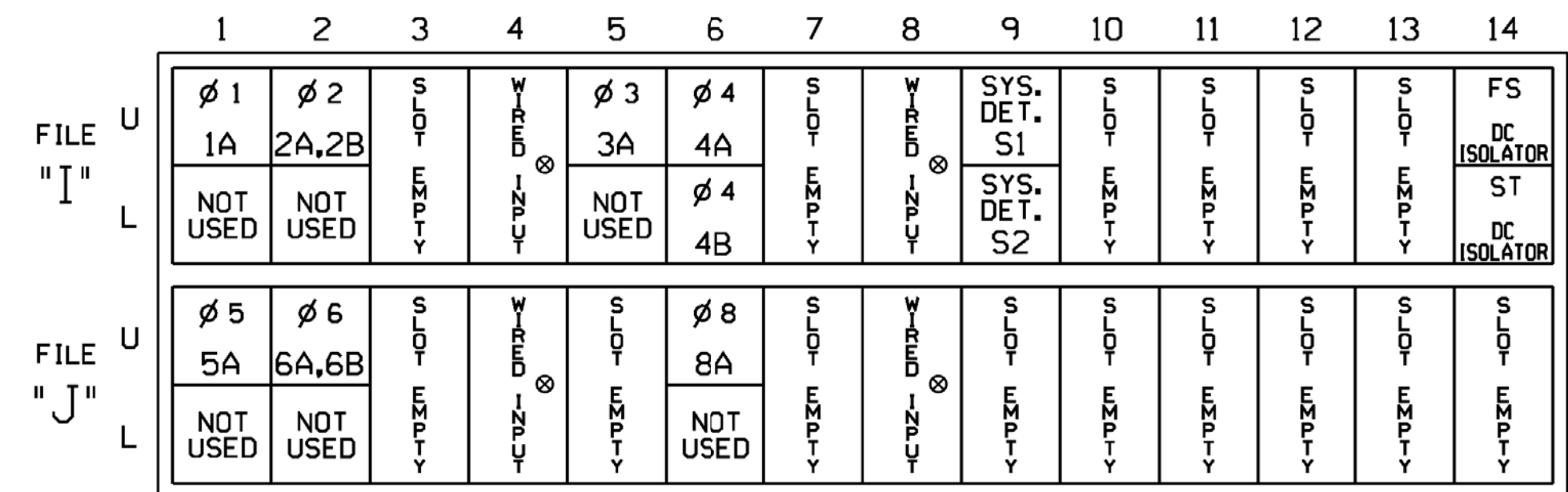

EX.: 1A, 2A, ETC. = LOOP NO.'S

FS = FLASH SENSE
 ST = STOP TIME

⊗ Wired Input - Do not populate slot with detector card

INPUT FILE CONNECTION & PROGRAMMING CHART

LOOP NO.	LOOP TERMINAL	INPUT FILE POS.	PIN NO.	DETECTOR NO.	NEMA PHASE	CALL	EXTEND TIME	DELAY TIME	ADDED INITIAL	DETECTOR TYPE
1A ¹	TB2-1,2	J1U	56	1	1	YES		15		S
		J4U	48	26	6	YES		3		G
2A, 2B	TB2-5,6	J2U	39	2	2	YES			X	N
3A ²	TB4-5,6	J5U	58	3	3	YES		15		S
		J8U	50	28	8	YES		3		S
4A	TB4-9,10	J6U	41	4	4	YES		3		S
4B	TB4-11,12	J6L	45	4	4	YES		10		S
* S1	TB6-9,10	J9U	60	11	SYS	NO				N
* S2	TB6-11,12	J9L	62	13	SYS	NO				N
5A ³	TB3-1,2	J1U	55	5	5	YES		15		S
		J4U	47	22	2	YES		3		G
6A, 6B	TB3-5,6	J2U	40	6	6	YES			X	N
8A	TB5-9,10	J6U	42	8	8	YES		10		S

* System detector only. Remove any assigned vehicle phase.

- Add jumper from J1-W to J4-W, on rear of input file.
- Add jumper from J5-W to J8-W, on rear of input file.
- Add jumper from J1-W to J4-W, on rear of input file.

* For the detectors to work as shown on the signal design plan, see the Vehicle Detector Setup Programming Detail for Alternate Phasing on sheet 3

INPUT FILE POSITION LEGEND: J2L

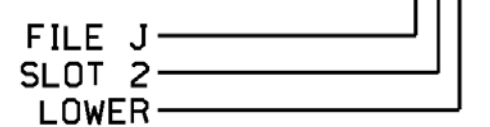

LOAD RESISTOR INSTALLATION DETAIL

(install resistors as shown)

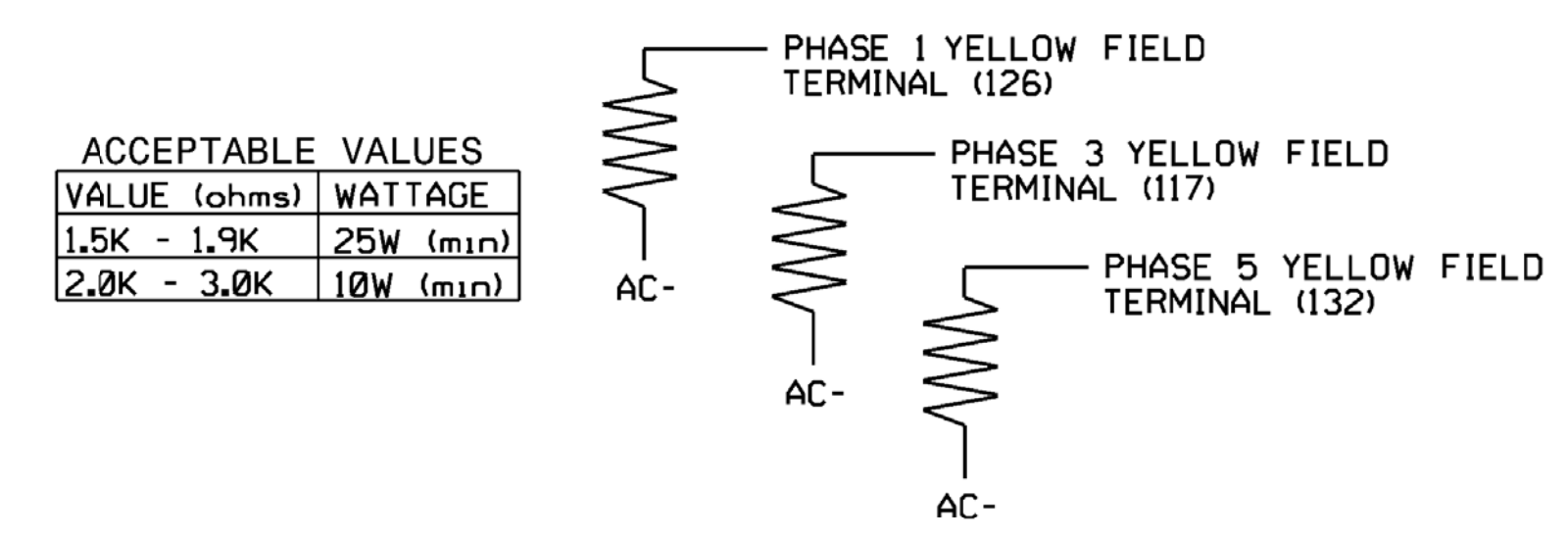

FYA SIGNAL WIRING DETAIL

(wire signal heads as shown)

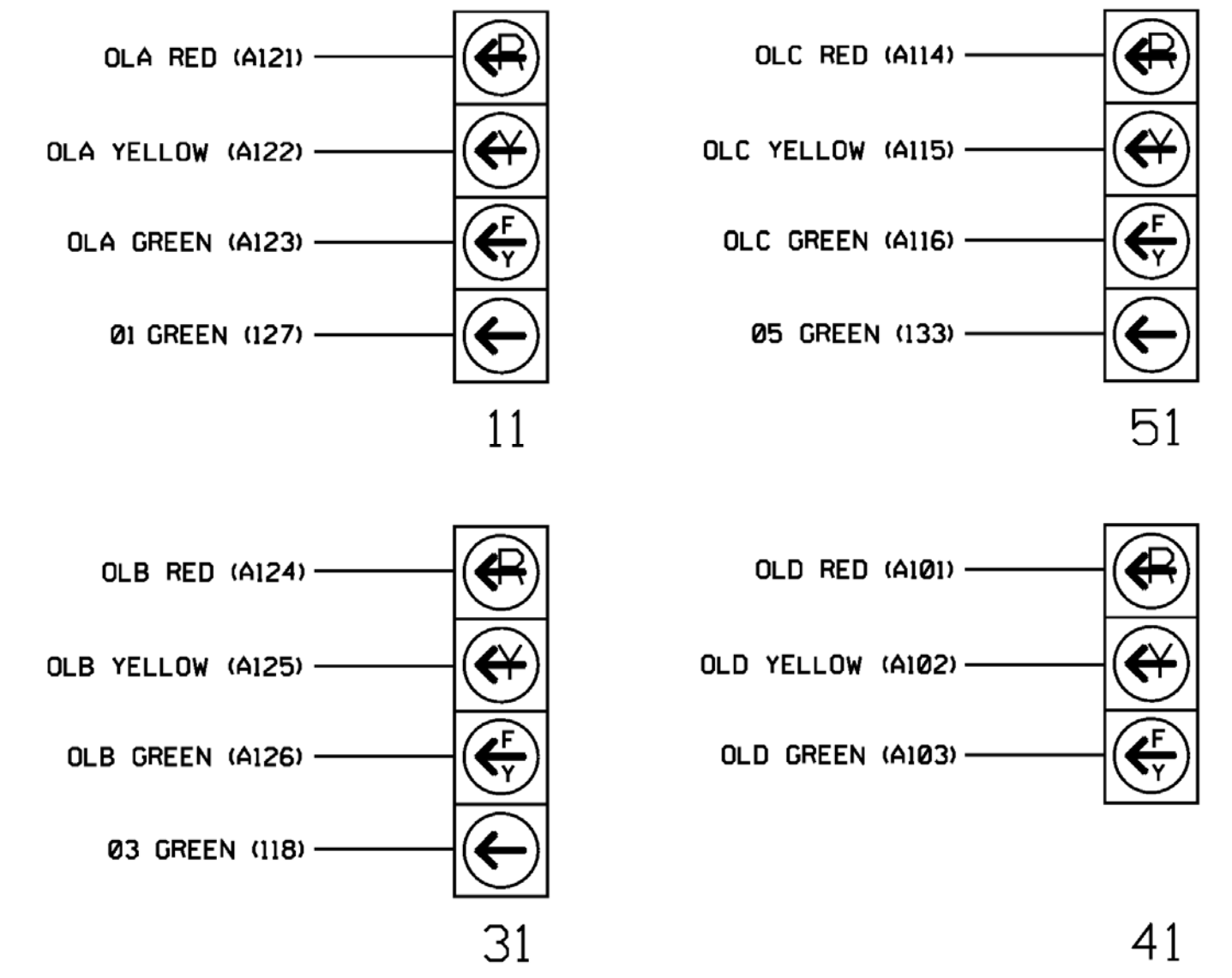

THIS ELECTRICAL DETAIL IS FOR THE SIGNAL DESIGN: 07-1806
 DESIGNED: April 2018
 SEALED: 6/13/2018
 REVISED: NA

Electrical Detail - Sheet 1 of 4

DOCUMENT NOT CONSIDERED FINAL UNLESS ALL SIGNATURES COMPLETED

Electrical and Programming Details For: **NC 87 (S. Main Street) at SR 2433 (Moore Street)**

Prepared for the Offices of: **James B. Voso**, Professional Engineer, License No. 022599, State of North Carolina.

Division 7 Alamance County, Graham

PLAN DATE: April 2018 REVIEWED BY: JB Voso
 PREPARED BY: SE Greene REVIEWED BY:

REVISIONS: _____ INIT. DATE

750 N. Greenfield Pkwy, Corner, NC 27529

12 BROAD STREET
 ASHEVILLE, NORTH CAROLINA 28801
 (828) 254-2201
 FAX (828) 254-4562
 NC LIC. NO. C-1154

SEAL
 JAMES B. VOSO
 6/13/2018
 DATE

SIG. INVENTORY NO. 07-1806

*****SYSTEM*****
 *****DIALOG*****
 *****USER*****

ECONOLITE ASC/3-2070 OVERLAP PROGRAMMING DETAIL

(program controller as shown)

1. From Main Menu select 2. CONTROLLER
2. From CONTROLLER Submenu select 2. VEHICLE OVERLAPS

OVERLAP A

Select TMG VEH OVLP [A] and 'PPLT FYA'

TMG VEH OVLP...[A] TYPE:PPLT FYA

PROTECTED LEFT TURN.... PHASE 1

OPPOSING THROUGH..... PHASE 2

FLASHING ARROW OUTPUT.....CH9 ISOLATE

DELAY START OF: FYA..0.0 CLEARANCE..0.0

ACTION PLAN SF BIT DISABLE..... 0

Toggle Once

OVERLAP B

Select TMG VEH OVLP [B] and 'PPLT FYA'

TMG VEH OVLP...[B] TYPE:PPLT FYA

PROTECTED LEFT TURN.... PHASE 3

OPPOSING THROUGH..... PHASE 4

FLASHING ARROW OUTPUT.....CH10 ISOLATE

DELAY START OF: FYA..0.0 CLEARANCE..0.0

ACTION PLAN SF BIT DISABLE..... 3

Toggle Once

← NOTICE ACTION PLAN SF BIT "3"

OVERLAP C

Select TMG VEH OVLP [C] and 'PPLT FYA'

TMG VEH OVLP...[C] TYPE:PPLT FYA

PROTECTED LEFT TURN.... PHASE 5

OPPOSING THROUGH..... PHASE 6

FLASHING ARROW OUTPUT.....CH11 ISOLATE

DELAY START OF: FYA..0.0 CLEARANCE..0.0

ACTION PLAN SF BIT DISABLE..... 0

Toggle Once

OVERLAP D

Select TMG VEH OVLP [D] and 'OTHER/ECONOLITE'

TMG VEH OVLP...[D] TYPE: OTHER/ECONOLITE

PHASES 1 2 3 4 5 6 7 8 9 0 1 2 3 4 5 6

INCLUDED X

PROTECT

PED PRTC

NOT OVLP

FLSH GRN 1

LAG X PH

LAG 2 PH

LAG GRN 0.0 YEL 0.0 RED 0.0 ADV GRN 0.0

END PROGRAMMING

FLASHER CIRCUIT MODIFICATION DETAIL

IN ORDER TO ENSURE THAT SIGNALS FLASH CONCURRENTLY ON THE SAME APPROACH, MAKE THE FOLLOWING FLASHER CIRCUIT CHANGES:

1. ON REAR OF PDA - REMOVE WIRE FROM TERM. T2-4 AND TERMINATE ON T2-2.
2. ON REAR OF PDA - REMOVE WIRE FROM TERM. T2-5 AND TERMINATE ON T2-3.
3. REMOVE FLASHER UNIT 2.

THE CHANGES LISTED ABOVE TIES ALL PHASES AND OVERLAPS TO FLASHER UNIT 1.

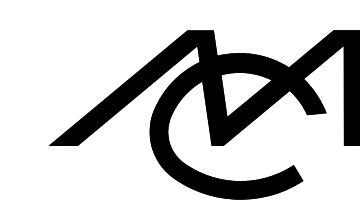

Mattern & Craig
ENGINEERS-SURVEYORS

12 BROAD STREET
ASHEVILLE, NORTH CAROLINA 28801
(828) 254-2201
FAX (828) 254-4562
NC LIC. NO. C-1154

THIS ELECTRICAL DETAIL IS FOR THE SIGNAL DESIGN: 07-1806

DESIGNED: April 2018

SEALED: 6/13/2018

REVISED: NA

Electrical Detail - Sheet 2 of 4

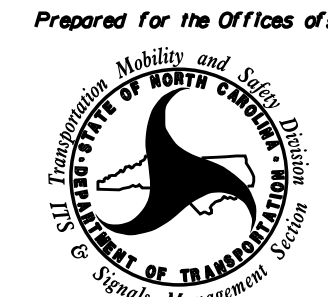
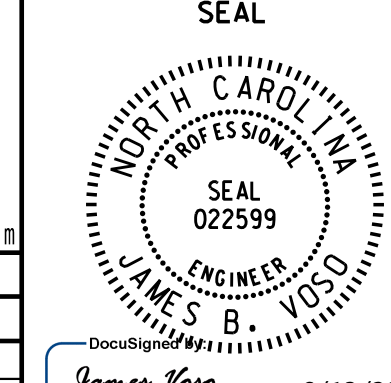
<p><small>ELECTRICAL AND PROGRAMMING DETAILS FOR:</small></p> <p style="text-align: center;">Prepared for the Offices of:</p>  <p style="text-align: center;"><small>750 N. Greenfield Pkwy, Corner, NC 27529</small></p>	<p>NC 87 (S. Main Street) at SR 2433 (Moore Street)</p> <p>Division 7 Alamance County Graham</p> <p>PLAN DATE: April 2018 REVIEWED BY: JB Voso</p> <p>PREPARED BY: SE Greene REVIEWED BY:</p> <table border="1" style="width: 100%; border-collapse: collapse;"> <thead> <tr> <th>REVISIONS</th> <th>INIT.</th> <th>DATE</th> </tr> </thead> <tbody> <tr><td> </td><td> </td><td> </td></tr> <tr><td> </td><td> </td><td> </td></tr> <tr><td> </td><td> </td><td> </td></tr> </tbody> </table>	REVISIONS	INIT.	DATE										<p><small>DOCUMENT NOT CONSIDERED FINAL UNLESS ALL SIGNATURES COMPLETED</small></p> <p style="text-align: center;">SEAL</p>  <p style="text-align: center;"><small>James Voso</small> 6/13/2018</p> <p style="text-align: center;"><small>DATE</small></p> <p style="text-align: center;"><small>SIG. INVENTORY NO. 07-1806</small></p>
REVISIONS	INIT.	DATE												

3:07:11 PM
 J:\3789 - Burlington Graham Signal System\06 Working Folders\Replace Sub-folders with NCDOT File Structure if Working on NCDOT Project\Wing or Dgn\07-1806-071806-sm.ele_20170404.dgn
 jvoso

ECONOLITE ASC/3-2070 VEHICLE DETECTOR SETUP PROGRAMMING DETAIL FOR ALTERNATE PHASING

LOOP 3A

(program controller as shown)

IMPORTANT!

Program detectors per the input file connection and programming chart shown on sheet 1 before proceeding.

- From Main Menu select **8. UTILITIES**
- From UTILITIES Submenu select **1. COPY/CLEAR**
- Copy from DETECTOR PLAN "1" to DETECTOR PLAN "2".

```

COPY / CLEAR UTILITY
FROM          TO
PHASE TIMING.... > PHASE TIMING....
TIMING PLAN.... > TIMING PLAN....
PH DET OPT PLAN. > PH DET OPT PLAN.
DETECTOR PLAN.. 1 > DETECTOR PLAN.. 2
TOGGLE TO SELECT A "FROM" AND A "TO"
THEN PRESS ENTER
    
```

- From Main Menu select **6. DETECTORS**
- From DETECTOR Submenu select **2. VEHICLE DETECTOR SETUP**
- Place cursor in VEH DET PLAN [] position and enter "2".
 - Place cursor in VEH DETECTOR [] position and enter "3".
 - Set delay time to "0".

```

VEH DETECTOR [ 3]  VEH DET PLAN [ 2] ← NOTICE VEH
TYPE: S-STANDARD  DET PLAN 2
TS2 DETECTOR..... ECPI LOG..... NO
DET PH - 1 2 3 4 5 6 7 8 9 0 1 2 3 4 5 6
      3 3 .....
EXTEND TIME... 0.0 DELAY TIME... 0.0 ← ENSURE DELAY
USE ADDED INITIAL . CROSS SWITCH PH.. 0 IS SET TO '0'
LOCK IN..... NONE NTCIP VOL . OR OCC .
PMT QUEUE DELAY. NO
    
```

- Place cursor in VEH DETECTOR [] position and enter "28".
- Set assigned phase to "0".

```

VEH DETECTOR [28]  VEH DET PLAN [ 2] ← NOTICE VEH
TYPE: S-STANDARD  DET PLAN 2
TS2 DETECTOR..... ECPI LOG..... NO
DET PH - 1 2 3 4 5 6 7 8 9 0 1 2 3 4 5 6
      28 0 ..... ← ENSURE PHASE
EXTEND TIME... 0.0 DELAY TIME... 3.0 IS SET TO "0"
USE ADDED INITIAL . CROSS SWITCH PH.. 0
LOCK IN..... NONE NTCIP VOL . OR OCC .
PMT QUEUE DELAY. NO
    
```

END PROGRAMMING

THIS ELECTRICAL DETAIL IS FOR
 THE SIGNAL DESIGN# 07-1806
 DESIGNED: April 2018
 SEALED: 6/13/2018
 REVISED: NA

Electrical Detail - Sheet 3 of 4

DOCUMENT NOT CONSIDERED
 FINAL UNLESS ALL
 SIGNATURES COMPLETED



12 BROAD STREET
 ASHEVILLE, NORTH CAROLINA 28801
 (828) 254-2201
 FAX (828) 254-4562
 NC LIC. NO. C-1154

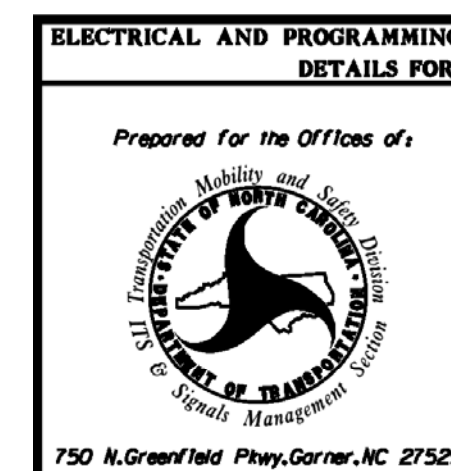

NC 87 (S. Main Street) at SR 2433 (Moore Street)	
Division 7	Alamance County
PREPARED BY: SE Greene	REVIEWED BY: JB Voso
DATE: April 2018	DATE: 6/13/2018
REVISIONS	INIT. DATE

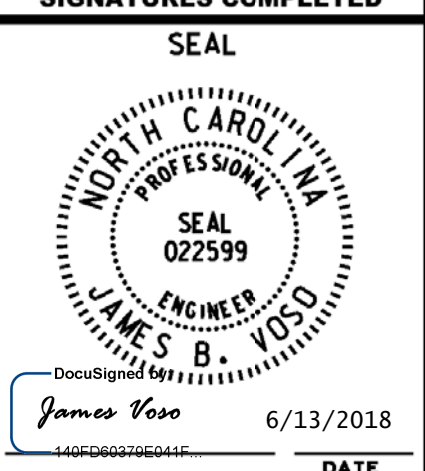

SIG. INVENTORY NO. 07-1806

*****SYTIME*****
 *****D*****
 *****USER*****

ECONOLITE ASC/3-2070 ACTION PLAN PROGRAMMING DETAIL

ALTERNATE PHASING ACTIVATION DETAIL

TO RUN ALT. PHASING DURING FREE RUN - PROGRAM CHANGES (SHOWN BELOW) IN A TIME BASED ACTION PLAN. SCHEDULE A DAY PLAN THAT INCLUDES THE ACTION PLAN PROGRAMMED TO SELECT VEH DET PLAN 2 AND ENABLE SF BIT 3.

TO RUN ALT. PHASING DURING COORDINATION - SELECT THE TIME BASED ACTION PLAN THAT IS PROGRAMMED TO SELECT VEH DET PLAN 2 AND ENABLE SF BIT 3.

PHASING	VEH DET PLAN	SF BITS ENABLED
ACTIONS REQUIRED TO RUN <u>DEFAULT PHASING</u>	1	NONE
ACTIONS REQUIRED TO RUN <u>ALTERNATE PHASING</u>	2	3

IMPORTANT: IF ALT. PHASING IS USED DURING FREE RUN AND COORDINATION, DO NOT OPERATE TIME OF DAY EVENTS CONCURRENTLY WITH COORDINATION PLAN EVENTS IN THE EVENT SCHEDULER. (EX. FREE RUN EVENT SHOULD END BEFORE COORDINATION PLAN EVENT STARTS AND VICE-VERSA).

ALTERNATE PHASING CHANGE SUMMARY

THE FOLLOWING IS A SUMMARY OF WHAT TAKES PLACE WHEN SF BIT 3 AND VEH DET PLAN 2 ACTIVATE TO CALL THE "ALTERNATE PHASING":

SF BIT 3: Modifies overlap parent phases for head 31 to run protected turns only.

VEH DET PLAN 2: Disables phase 8 call on loop 3A and reduces delay time for phase 3 call on loop 3A to 0 seconds.

1. From Main Menu select 5. TIME BASE
2. From TIME BASE Submenu select 2. ACTION PLAN

```

ACTION PLAN...[ 1]
PATTERN.....AUTO   SYS OVERRIDE.... NO
TIMING PLAN..... 0   SEQUENCE..... 0
VEH DETECTOR PLAN.. 2   DET LOG.....NONE
FLASH..... --   RED REST..... NO
VEH DET DIAG PLN... 0   PED DET DIAG PLN..0
DIMMING ENABLE.. NO   PRIORITY RETURN. NO
PED PR RETURN.. NO   QUEUE DELAY..... NO
PMT COND DELAY   NO
  PHASE  1  2  3  4  5  6  7  8  9  0  1  2  3  4  5  6
PED RCL   .  .  .  .  .  .  .  .  .  .  .  .  .  .  .  .
WALK 2    .  .  .  .  .  .  .  .  .  .  .  .  .  .  .  .
VEX 2     .  .  .  .  .  .  .  .  .  .  .  .  .  .  .  .
VEH RCL   .  .  .  .  .  .  .  .  .  .  .  .  .  .  .  .
MAX RCL   .  .  .  .  .  .  .  .  .  .  .  .  .  .  .  .
MAX 2     .  .  .  .  .  .  .  .  .  .  .  .  .  .  .  .
  PHASE  1  2  3  4  5  6  7  8  9  0  1  2  3  4  5  6
MAX 3     .  .  .  .  .  .  .  .  .  .  .  .  .  .  .  .
CS INH    .  .  .  .  .  .  .  .  .  .  .  .  .  .  .  .
OMIT      .  .  .  .  .  .  .  .  .  .  .  .  .  .  .  .
SPC FCT   .  .  X  .  .  .  .  .  .  .  .  .  .  .  .  .
AUX FCT   .  .  .  (1-3)
          1  2  3  4  5  6  7  8  9  0  1  2  3  4  5
LP 1-15   .  .  .  .  .  .  .  .  .  .  .  .  .  .  .  .
LP 16-30  .  .  .  .  .  .  .  .  .  .  .  .  .  .  .  .
LP 31-45  .  .  .  .  .  .  .  .  .  .  .  .  .  .  .  .
LP 46-60  .  .  .  .  .  .  .  .  .  .  .  .  .  .  .  .
LP 61-75  .  .  .  .  .  .  .  .  .  .  .  .  .  .  .  .
LP 76-90  .  .  .  .  .  .  .  .  .  .  .  .  .  .  .  .
LP 91-100 .  .  .  .  .  .  .  .  .  .  .  .  .  .  .  .
  
```

Mattern & Craig
ENGINEERS & SURVEYORS

12 BROAD STREET
ASHEVILLE, NORTH CAROLINA 28801
(828) 254-2201
FAX (828) 254-4562
NC LIC. NO. C-1154

THIS ELECTRICAL DETAIL IS FOR
THE SIGNAL DESIGN: 07-1806
DESIGNED: April 2018
SEALED: 6/13/2018
REVISED: NA

Electrical Detail - Sheet 4 of 4

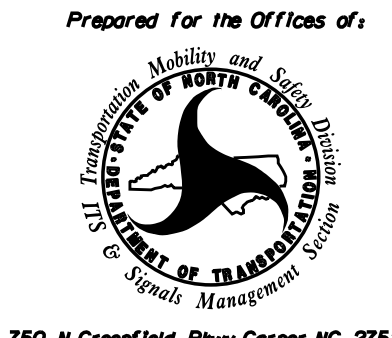
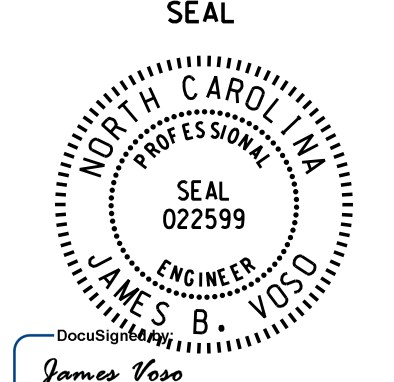
 <p style="font-size: 8px;">750 N. Greenfield Pkwy, Corner, NC 27529</p>	<p>NC 87 (S. Main Street) at SR 2433 (Moore Street)</p> <p>Division 7 Alamance County Graham</p> <p>PLAN DATE: April 2018 REVIEWED BY: JB Voso</p> <p>PREPARED BY: SE Greene REVIEWED BY:</p>	<p>DOCUMENT NOT CONSIDERED FINAL UNLESS ALL SIGNATURES COMPLETED</p> <p>SEAL</p>  <p>James Voso 6/13/2018 DATE</p> <p>SIG. INVENTORY NO. 07-1806</p>
---	---	---

3:08:14 PM 11/13/18 - Burlington Graham Signal System06 Working Folders with NCDOT File Structure if Working on NCDOT Project\Wing or Dgn\07-1806-071806-sm.ele-20170404.dgn jvoso

PHASING DIAGRAM

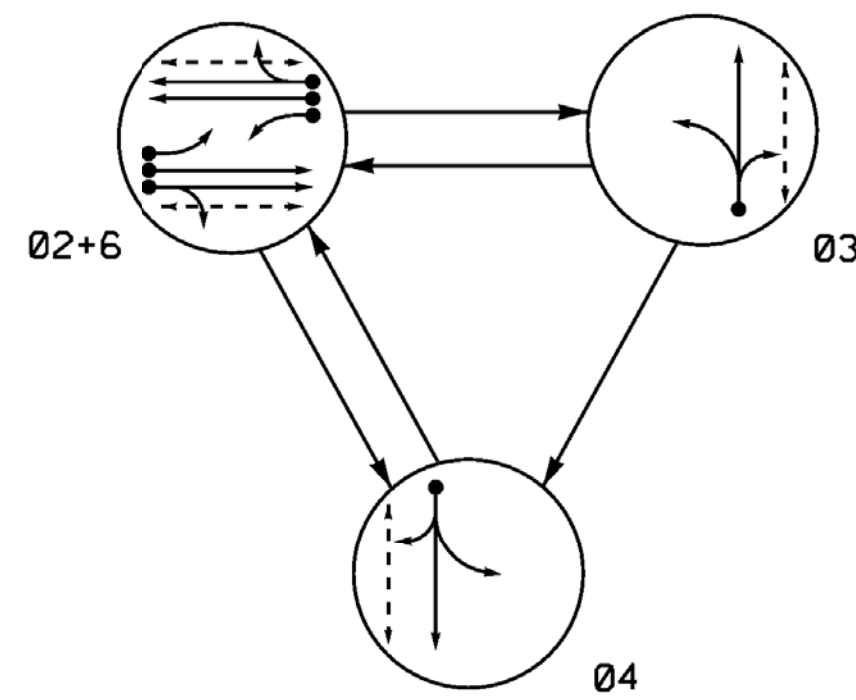

PHASING DIAGRAM DETECTION LEGEND

- ←●→ DETECTED MOVEMENT
- ←○→ UNDETECTED MOVEMENT (OVERLAP)
- UNSIGNALIZED MOVEMENT
- ←- - -> PEDESTRIAN MOVEMENT

SIGNAL FACE	PHASE			
	02+6	03	04	FLASH
21, 22	G	R	R	Y
31	R	G	R	R
32	R	G	R	R
41	R	R	G	R
42	R	R	G	R
61, 62	G	R	R	Y
P21, P22	W	DW	DW	DRK
P31, P32	DW	W	DW	DRK
P41, P42	DW	DW	W	DRK
P61, P62	W	DW	DW	DRK

SIGNAL FACE I.D.

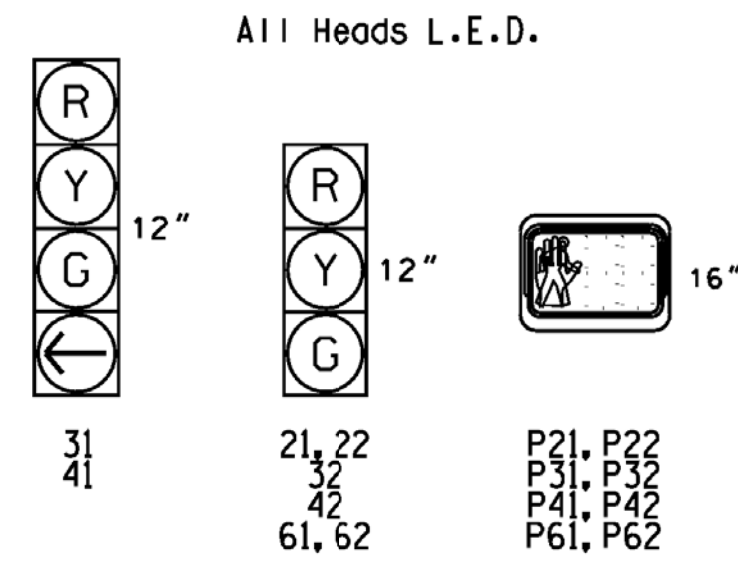

ASC/3 DETECTOR INSTALLATION CHART											
DETECTOR						PROGRAMMING					
LOOP	SIZE (FT)	DISTANCE FROM STOPBAR (FT)	TURNS	NEW LOOP	PHASE	CALLING	EXTEND TIME	DELAY TIME	USE ADDED INITIAL	TYPE	LOOP
2A	6x6	80	EXIST.	-	2	Yes	-	-	-	S	X
2B	6x6	80	EXIST.	-	2	Yes	-	-	-	S	X
2C	6x40	0	2-4-2	-	2	Yes	-	-	-	S	X
3A	6x40	+10	2-4-2	-	3	Yes	-	5	-	S	X
4A	6x40	+10	2-4-2	-	4	Yes	-	5	-	S	X
6A	6x6	70	EXIST.	-	6	Yes	-	-	-	S	X
6B	6x6	70	EXIST.	-	6	Yes	-	-	-	S	X
6C	6x40	0	2-4-2	-	6	Yes	-	-	-	S	X
S1	6x6	+175	4	X	-	No	-	-	-	N	X
S2	6x6	+175	4	X	-	No	-	-	-	N	X

3 Phase Fully Actuated (Burlington-Graham Signal System)

NOTES

- Refer to "Roadway Standard Drawings NCDOT" dated January 2018 and "Standard Specifications for Roads and Structures" dated January 2018.
- Do not program signal for late night flashing operation unless otherwise directed by the Engineer.
- Set all detector units to presence mode.
- In the event of loop replacement, refer to the current ITS and Signals Design Manual and submit a Plan of Record to the Signal Design Section.
- Locate new cabinet so as not to obstruct sight distance of vehicles turning right on red.
- The cabinet should be designed to include an Auxiliary Output file for future use.
- Omit "WALK" and flashing "DON'T WALK" with no pedestrian calls.
- Program pedestrian heads to countdown the flashing "Don't Walk" time only.
- Pavement markings are existing.
- Maximum times shown in timing chart are for free-run operation only. Coordinated signal system timing values supersede these values.
- The order of phase 3 and phase 4 may be reversed.

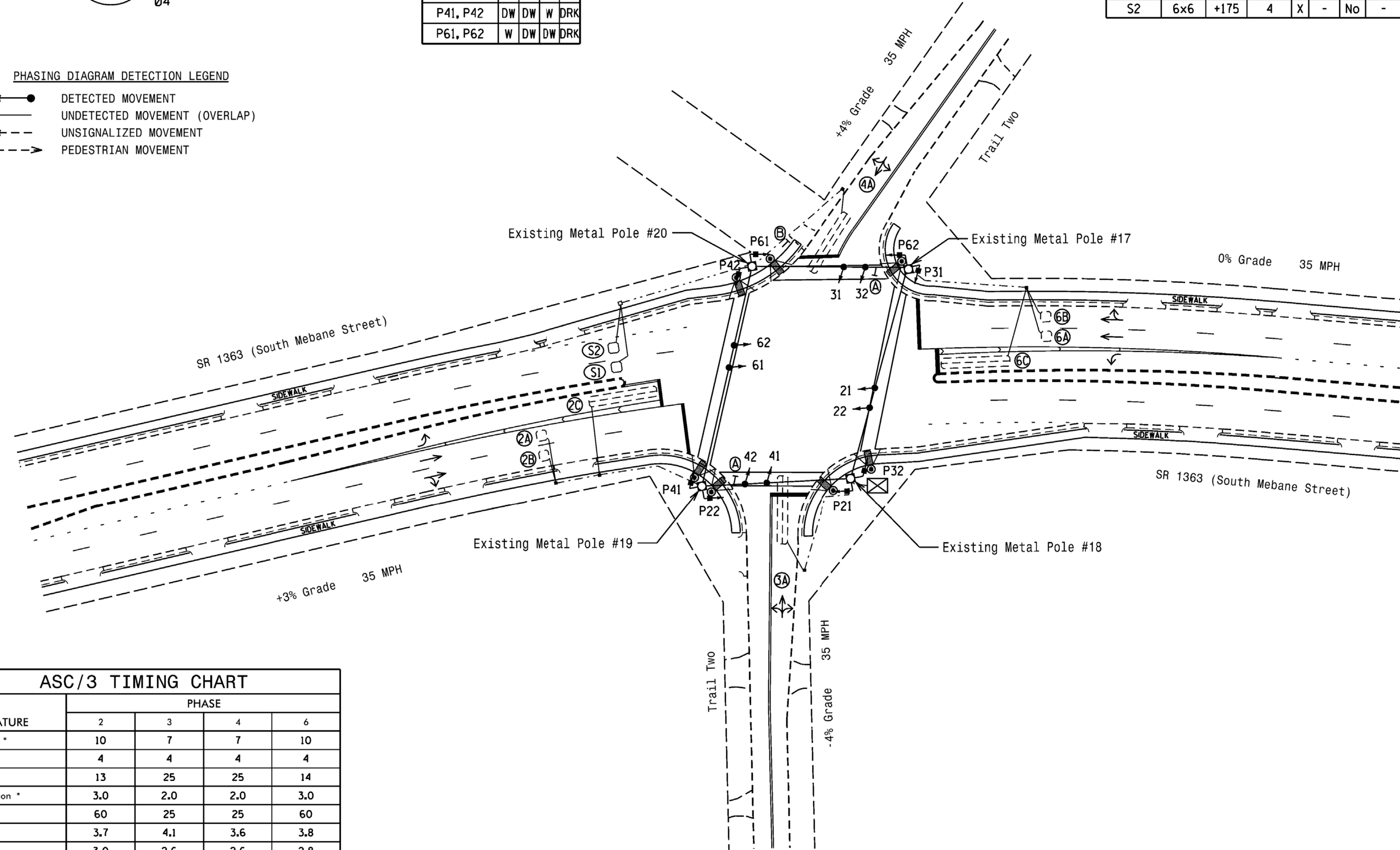

LEGEND

- | PROPOSED | EXISTING |
|----------|----------|
| ○→ | ●→ |
| ○→ | N/A |
| ⊥ | ⊥ |
| ⊥ | ⊥ |
| ○→ | ●→ |
| ○→ | ●→ |
| ⊠ | ⊠ |
| □ | □ |
| N/A | ⊠ |
| --- | --- |
| N/A | --- |
| → | → |
| N/A | ⊙ |
| ⊙ | ⊙ |
| ⊙ | ⊙ |

FEATURE	PHASE			
	2	3	4	6
Min Green *	10	7	7	10
Walk *	4	4	4	4
Ped Clear	13	25	25	14
Veh. Extension *	3.0	2.0	2.0	3.0
Max I *	60	25	25	60
Yellow	3.7	4.1	3.6	3.8
Red Clear	3.0	2.6	2.6	2.8
Actuations B4 Add *	-	-	-	-
Seconds / Actuation *	-	-	-	-
Max Initial *	-	-	-	-
Time Before Reduction *	-	-	-	-
Time To Reduce *	-	-	-	-
Minimum Gap	-	-	-	-
Locking Detector	X	-	-	X
Recall Position	VEH. RECALL	-	-	VEH. RECALL
Dual Entry	-	-	-	-
Simultaneous Gap	X	X	X	X

* These values may be field adjusted. Do not adjust Min Green and Extension times for phases 2 and 6 lower than what is shown. Min Green for all other phases should not be lower than 4 seconds.



12 BROAD STREET
ASHEVILLE, NORTH CAROLINA 28801
(828) 254-2201
FAX (828) 254-4562
NC LIC. NO. C-1154

Signal Upgrade

Prepared for the Offices of:
TRANSPORTATION MOBILITY AND SAFETY DIVISION
DEPARTMENT OF TRANSPORTATION
Signal Design Section
750 N. Greenfield Pkwy, Garner, NC 27529
SCALE 0 40
1"=40'

DOCUMENT NOT CONSIDERED FINAL UNLESS ALL SIGNATURES COMPLETED

SR 1363 (South Mebane Street) at Trail Two

Division 7 Alamance County Burlington

PLAN DATE: September 2017 REVIEWED BY: JB Voso

PREPARED BY: SE Wilson REVIEWED BY:

REVISIONS

INIT. DATE

SEAL
NORTH CAROLINA
PROFESSIONAL ENGINEER
JAMES B. VOSO
022599
6/13/2018
DATE
SIG. INVENTORY NO. 07-1852

*****SYTIME*****
*****BUSINESS*****

**EDI MODEL 2018EClip-NC CONFLICT MONITOR
PROGRAMMING DETAIL**

(remove jumpers and set switches as shown)

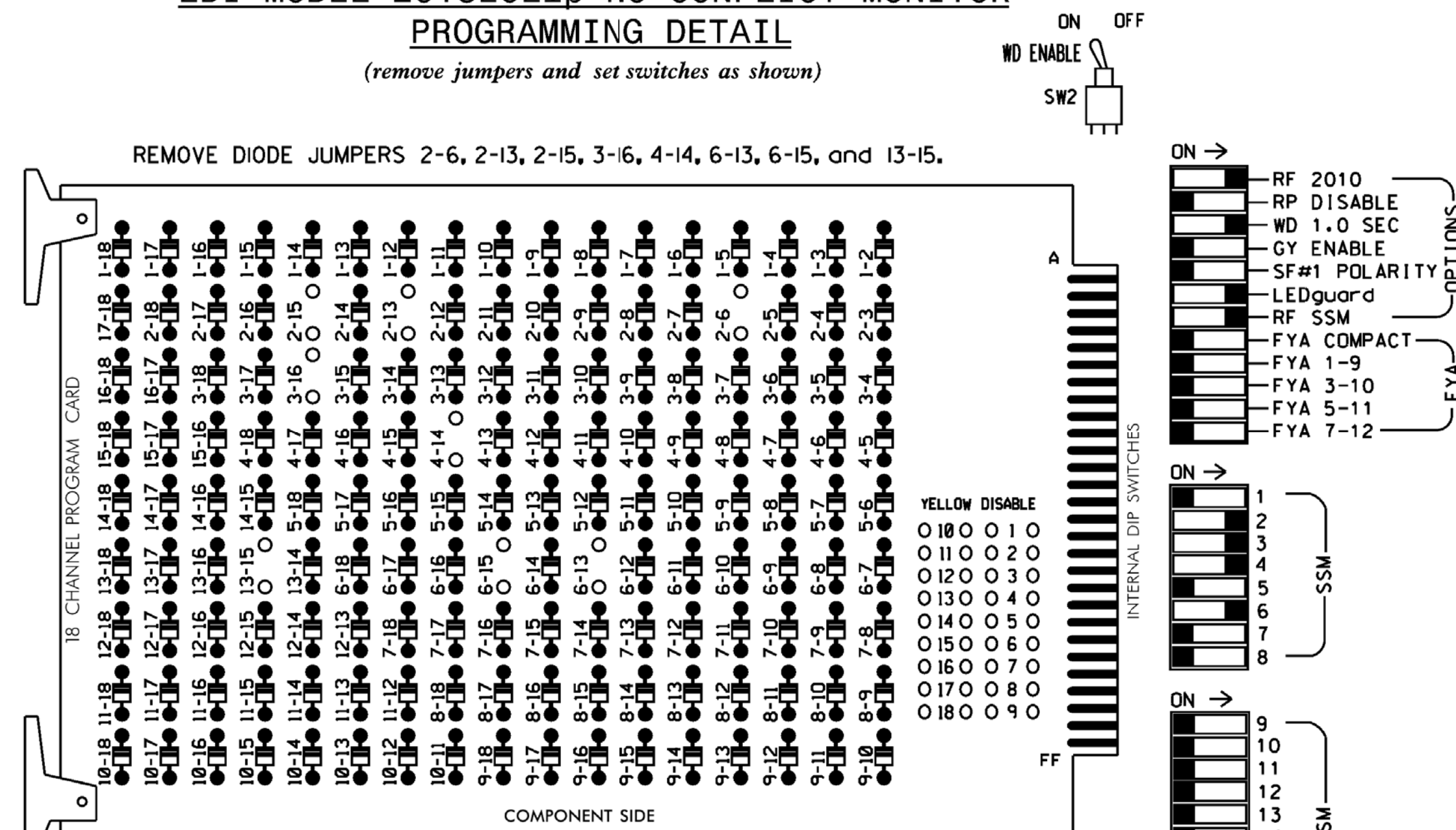

NOTES:

1. Card is provided with all diode jumpers in place. Removal of any jumper allows its channels to run concurrently.
2. Ensure jumpers SEL2-SEL5 and SEL9 are present on the monitor board.
3. Ensure that Red Enable is active at all times during normal operation.
4. Integrate monitor with Ethernet network in cabinet.

NOTES

1. To prevent "flash-conflict" problems, insert red flash program blocks for all unused vehicle load switches in the output file. The installer shall verify that signal heads flash in accordance with the Signal Plans.
2. Program controller to start up in phase 2 Walk and 6 Walk.
3. The cabinet and controller are part of the Burlington-Graham Signal System.

EQUIPMENT INFORMATION

CONTROLLER.....2070LX
 CABINET.....332 /W/ AUX
 SOFTWARE.....ECONOLITE ASC/3-2070
 CABINET MOUNT.....BASE
 OUTPUT FILE POSITIONS...18 WITH AUX. OUTPUT FILE
 LOAD SWITCHES USED.....S2,S3,S4,S5,S6,S8,S9,S12
 PHASES USED.....2,2PED,3,3PED,4,4PED,6,6PED
 OVERLAP "A".....NOT USED
 OVERLAP "B".....NOT USED
 OVERLAP "C".....NOT USED
 OVERLAP "D".....NOT USED

SIGNAL HEAD HOOK-UP CHART

LOAD SWITCH NO.	S1	S2	S3	S4	S5	S6	S7	S8	S9	S10	S11	S12	AUX S1	AUX S2	AUX S3	AUX S4	AUX S5	AUX S6
CMU CHANNEL NO.	1	2	13	3	4	14	5	6	15	7	8	16	9	10	17	11	12	18
PHASE	1	2	2 PED	3	4	4 PED	5	6	6 PED	7	8	3 PED	OLA	OLB	SPARE	OLC	OLD	SPARE
SIGNAL HEAD NO.	NU	21,22	P21 P22	31	32	41	42	P41 P42	NU	61,62	P61 P62	NU	NU	P31 P32	NU	NU	NU	NU
RED		128		116	116	101	101			134								
YELLOW		129		117	117	102	102			135								
GREEN		130		118	118	103	103			136								
RED ARROW																		
YELLOW ARROW																		
GREEN ARROW																		
Hand icon				113				104		119		110						
Person icon				115				106		121		112						

NU = Not Used

INPUT FILE POSITION LAYOUT

(front view)

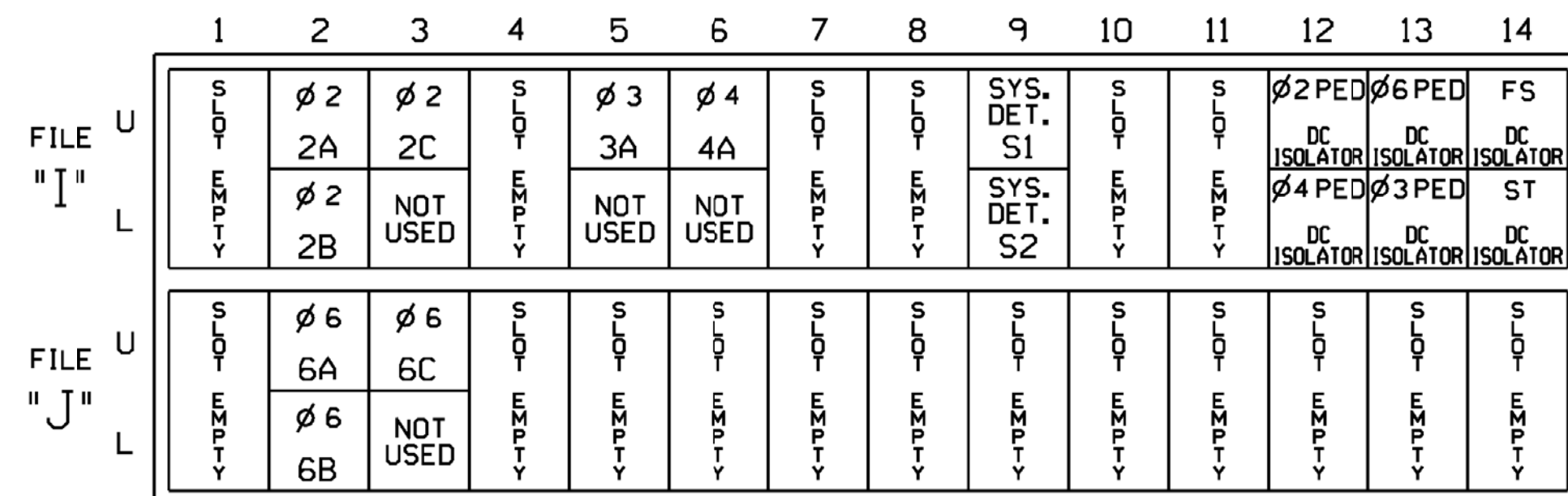

EX. 1A, 2A, ETC. = LOOP NO.'S

FS = FLASH SENSE
 ST = STOP TIME

INPUT FILE CONNECTION & PROGRAMMING CHART

LOOP NO.	LOOP TERMINAL	INPUT FILE POS.	PIN NO.	DETECTOR NO.	NEMA PHASE	CALL	EXTEND TIME	DELAY TIME	ADDED INITIAL	DETECTOR TYPE
2A	TB2-5,6	I2U	39	2	2	YES				S
2B	TB2-7,8	I2L	43	12	2	YES				S
2C	TB2-9,10	I3U	63	32	2	YES				S
3A	TB4-5,6	I5U	58	3	3	YES		5		S
4A	TB4-9,10	I6U	41	4	4	YES		5		S
* S1	TB6-9,10	I9U	60	11	SYS	NO				N
* S2	TB6-11,12	I9L	62	13	SYS	NO				N
6A	TB3-5,6	J2U	40	6	6	YES				S
6B	TB3-7,8	J2L	44	16	6	YES				S
6C	TB3-9,10	J3U	64	36	6	YES				S
PED PUSH BUTTONS										
P21,P22	TB8-4,6	I12U	67	PED 2	2 PED					
P31,P32	TB8-8,9	I13L	70	PED 8	3 PED					
P41,P42	TB8-5,6	I12L	69	PED 4	4 PED					
P61,P62	TB8-7,9	I13U	68	PED 6	6 PED					

NOTE:
 Install DC isolators in input file slots 112 and 113.

* System Detector only. Remove any assigned vehicle phase.

INPUT FILE POSITION LEGEND: J2L

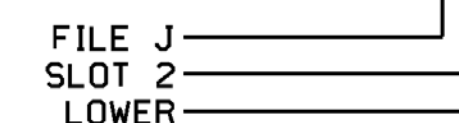

COUNTDOWN PEDESTRIAN SIGNAL OPERATION

Countdown Ped Signals are required to display timing only during Ped Clearance Interval. Consult Ped Signal Module user's manual for instructions on selecting this feature.

THIS ELECTRICAL DETAIL IS FOR THE SIGNAL DESIGN: 07-1852
 DESIGNED: September 2017
 SEALED: 6/13/2018
 REVISED: NA

Electrical Detail - Sheet 1 of 2

DOCUMENT NOT CONSIDERED FINAL UNLESS ALL SIGNATURES COMPLETED

SEAL

MORTH CAROLINA PROFESSIONAL ENGINEER SEAL 022599

James B. Voso

6/13/2018

SIG. INVENTORY NO. 07-1852

Electrical and Programming Details For: SR 1363 (South Mebane Street) at Trail Two

Division 7 Alamance County Burlington

PLAN DATE: September 2017 REVIEWED BY: JB Voso

PREPARED BY: SE Wilson REVIEWED BY:

REVISIONS

INIT. DATE

James Voso 6/13/2018

750 N. Greenfield Pkwy, Corner, NC 27529



12 BROAD STREET
 ASHEVILLE, NORTH CAROLINA 28801
 (828) 254-2201
 FAX (828) 254-4562
 NC LIC. NO. C-1154

*****SYTIME*****
 *****D*****
 *****USER*****

ECONOLITE ASC/3-2070 PED 3 PROGRAMMING ASSIGNMENT DETAIL

(program controller as shown)

1. From Main Menu select 6. DETECTORS
2. From DETECTOR Submenu select 3. PED DETECTOR INPUT ASSIGNMENT

```

PED DET PHASE ASSIGNMENT MODE: NTCIP

  PHASE 1  2  3  4  5  6  7  8
DETECTOR 0  2  8  4  0  6  0  0

  PHASE 9 10 11 12 13 14 15 16
DETECTOR 0  0  0  0  0  0  0  0

```

← NOTICE PED DETECTOR 8
ASSIGNED TO PHASE 3

1. From Main Menu select 1. CONFIGURATION
2. From CONFIGURATION Submenu select 3. LOAD SW ASSIGN

```

LD SWITCH ASSIGN
PHASE  DIMMING ---FLASH---
/OVLP TYPE R Y G D PWR AUT TGR
1  1  V . . . + A R X
2  2  V . . . + A Y .
3  3  V . . . + A R X
4  4  V . . . + A R .
5  5  V . . . - A R .
6  6  V . . . - A Y X
7  7  V . . . - A R .
8  8  V . . . - A R X
9  1  O . . . + A R X
10 2  O . . . + A R X
11 3  O . . . - A R .
12 4  O . . . - A R .
13 2  P . . . + A . .
14 4  P . . . - A . .
15 6  P . . . + A . .
16 3  P . . . - A . .

```

NOTICE PHASE 3 PED
ASSIGNED TO LD SWITCH 16 →

THIS ELECTRICAL DETAIL IS FOR
THE SIGNAL DESIGN: 07-1852
DESIGNED: September 2017
SEALED: 6/13/2018
REVISED: NA

\$\$\$\$\$\$SYTIME\$\$\$\$\$\$
 \$\$\$\$\$\$SUDOON\$\$\$\$\$\$
 \$\$\$\$\$\$SERNAME\$\$\$\$\$\$

Electrical Detail - Sheet 2 of 2



Mattern & Craig
ENGINEERS • SURVEYORS

12 BROAD STREET
ASHEVILLE, NORTH CAROLINA 28801
(828) 254-2201
FAX (828) 254-4562
NC LIC. NO. C-1154

ELECTRICAL AND PROGRAMMING
DETAILS FOR:



750 N. Greenfield Pkwy, Garner, NC 27529

SR 1363 (South Mebane Street)	
at Trail Two	
Division 7	Alamance County
PLAN DATE: September 2017	REVIEWED BY: JB Voso
PREPARED BY: SE Wilson	REVIEWED BY:
REVISIONS	INIT. DATE

**DOCUMENT NOT CONSIDERED
FINAL UNLESS ALL
SIGNATURES COMPLETED**

SEAL



James Voso 6/13/2018
SIGNATURE DATE

SIG. INVENTORY NO. 07-1852

PHASING DIAGRAM

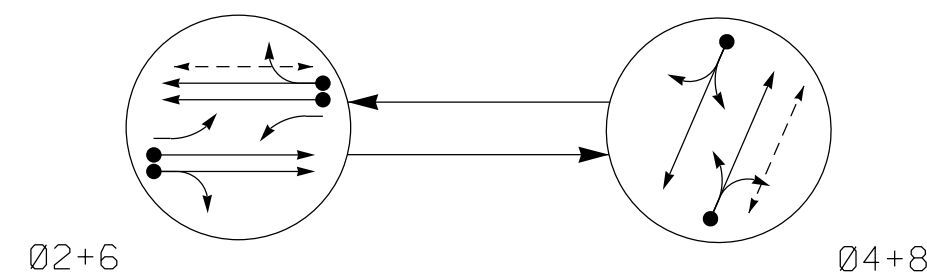

PHASING DIAGRAM DETECTION LEGEND

- ←●→ DETECTED MOVEMENT
- ←○→ UNDETECTED MOVEMENT (OVERLAP)
- ←---→ UNSIGNALIZED MOVEMENT
- ←---> PEDESTRIAN MOVEMENT

TABLE OF OPERATION

SIGNAL FACE	PHASE		
	02+6	04+8	FLASH
21, 22	G	R	Y
41, 42	R	G	R
61, 62	G	R	Y
81, 82	R	G	R
P61, P62	W	DW	DRK
P81, P82	DW	W	DRK

SIGNAL FACE I.D.

All Heads L.E.D.

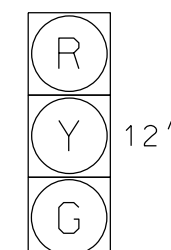

12"
21,22
41,42
61,62
81,82

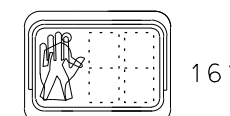

16"
P61,P62
P81,P82

ASC/3 DETECTOR INSTALLATION CHART

LOOP	SIZE (FT)	DISTANCE FROM STOPBAR (FT)	TURNS	NEW LOOP	PROGRAMMING						TYPE	SYSTEM LOOP	NEW CARD
					PHASE	CALLING	EXTEND TIME	DELAY TIME	USE ADDED INITIAL				
2A	6X6	70	Exist	-	2	Yes	-	-	-	-	S	-	X
2B	6X6	70	Exist	-	2	Yes	-	-	-	-	S	-	X
2C*	6X6	300	Exist	-	2	-	-	-	-	-	S	-	-
2D*	6X6	300	Exist	-	2	-	-	-	-	-	S	-	-
4A	6X60	0	2-4-2	-	4	Yes	10	-	-	-	S	-	X
6A	6X6	70	Exist	-	6	Yes	-	-	-	-	S	-	X
6B	6X6	70	Exist	-	6	Yes	-	-	-	-	S	-	X
6C*	6X6	300	Exist	-	6	-	-	-	-	-	S	-	-
6D*	6X6	300	Exist	-	6	-	-	-	-	-	S	-	-
8A	6X60	0	2-4-2	-	8	Yes	10	-	-	-	S	-	X

* DISCONNECT LOOP

2 Phase Fully Actuated (Burlington-Graham Signal System)

NOTES

- Refer to "Roadway Standard Drawings NCDOT" dated January 2018 and "Standard Specifications for Roads and Structures" dated January 2018.
- Do not program signal for late night flashing operation unless otherwise directed by the Engineer.
- Loop data based on previous plan and field observations.
- In the event of loop replacement, refer to the current ITS and Signals Design Manual and submit a Plan of Record to the Signal Design Section.
- Set all detector units to presence mode.
- Locate new cabinet so as not to obstruct sight distance of vehicles turning right on red.
- Omit "WALK" and flashing "DON'T WALK" with no pedestrian calls.
- Program pedestrian heads to countdown the flashing "Don't Walk" time only.
- Pavement markings are existing except where noted on plan.
- Maximum times shown in timing chart are for free-run operation only. Coordinated signal system timing values supersede these values.

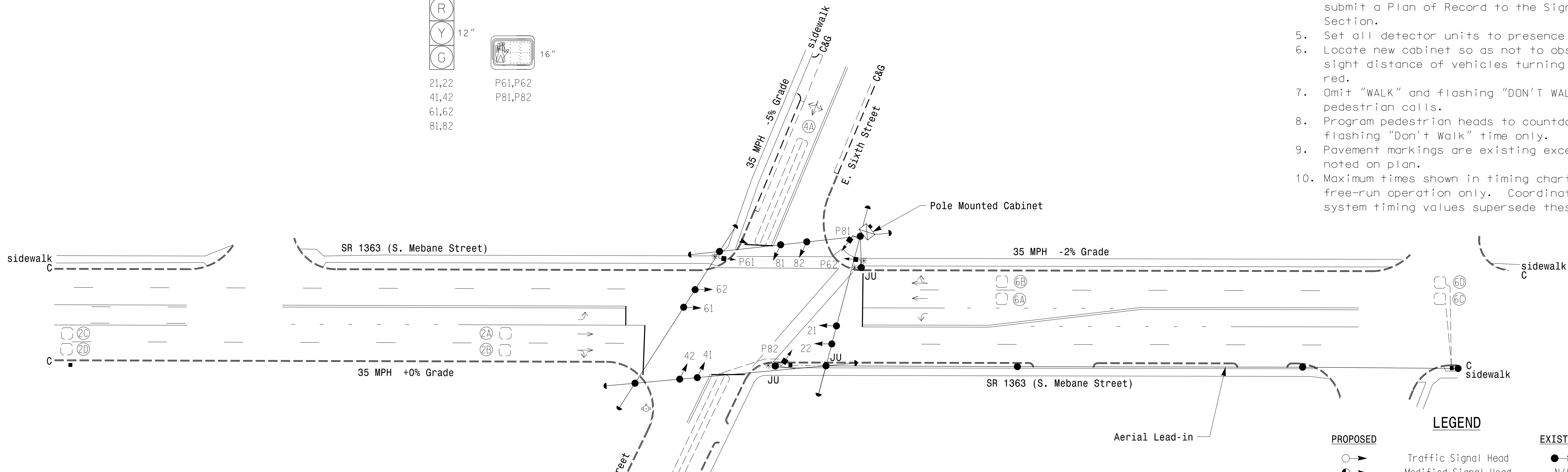

ASC/3 TIMING CHART

FEATURE	PHASE			
	2	4	6	8
Min Green *	10	7	10	7
Walk *	0	0	4	4
Ped Clear	0	0	13	16
Veh. Extension *	3.0	1.0	3.0	1.0
Max 1 *	45	30	45	30
Yellow	3.8	4.2	4.0	3.5
Red Clear	2.0	1.4	1.9	1.3
Actuations B4 Add *	-	-	-	-
Seconds /Actuation *	-	-	-	-
Max Initial *	-	-	-	-
Time Before Reduction *	-	-	-	-
Time To Reduce *	-	-	-	-
Minimum Gap	-	-	-	-
Locking Detector	X	-	X	-
Recall Position	VEH. RECALL	-	VEH. RECALL	-
Dual Entry	-	X	-	X
Simultaneous Gap	X	X	X	X

* These values may be field adjusted. Do not adjust Min Green and Extension times for phases 2 and 6 lower than what is shown. Min Green for all other phases should not be lower than 4 seconds.

LEGEND

PROPOSED	EXISTING
○→ Traffic Signal Head	●→ N/A
○→ Modified Signal Head	- N/A
□ Sign	□
□ Pedestrian Signal Head	□
* Pedestrian Push Button & Sign	*
○ Signal Pole with Guy	●
○ Signal Pole with Sidewalk Guy	●
□ Inductive Loop Detector	□
□ Controller & Cabinet	□
□ Junction Box	□
--- 2-in Underground Conduit	---
N/A Right of Way	---
→ Directional Arrow	→
N/A Fire Hydrant	⊕

Signal Upgrade

DOCUMENT NOT CONSIDERED FINAL UNLESS ALL SIGNATURES COMPLETED

Plans Prepared By:

DRMP, Inc.
8000 Regency Parkway, Suite 175
Cary, NC 27519
NC License No. C-2213 (919) 650-1038

SR 1363 (S. Mebane Street) at E. Sixth Street

Division 7 Alamance County Burlington

PLAN DATE: November 2017 REVIEWED BY: AJ Davis

PREPARED BY: RD Lawton REVIEWED BY: LM Moon

REVISIONS	INIT.	DATE

SEAL

STATE OF NORTH CAROLINA

PROFESSIONAL ENGINEER

022516

Lisa M. Moon 6/13/2018

SIGNATURE DATE

SIG. INVENTORY NO. 07-1886

13-UNA-2018-17-47
 R:\60605\17\off\caks\gnals\000\sig\07-1886.dgn
 KANDERSON AT CHA-KANDERSON

EDI MODEL 2018ECLip-NC CONFLICT MONITOR PROGRAMMING DETAIL

(remove jumpers and set switches as shown)

REMOVE DIODE JUMPERS 2-6, 2-15, 4-8, 4-16, 6-15, and 8-16.

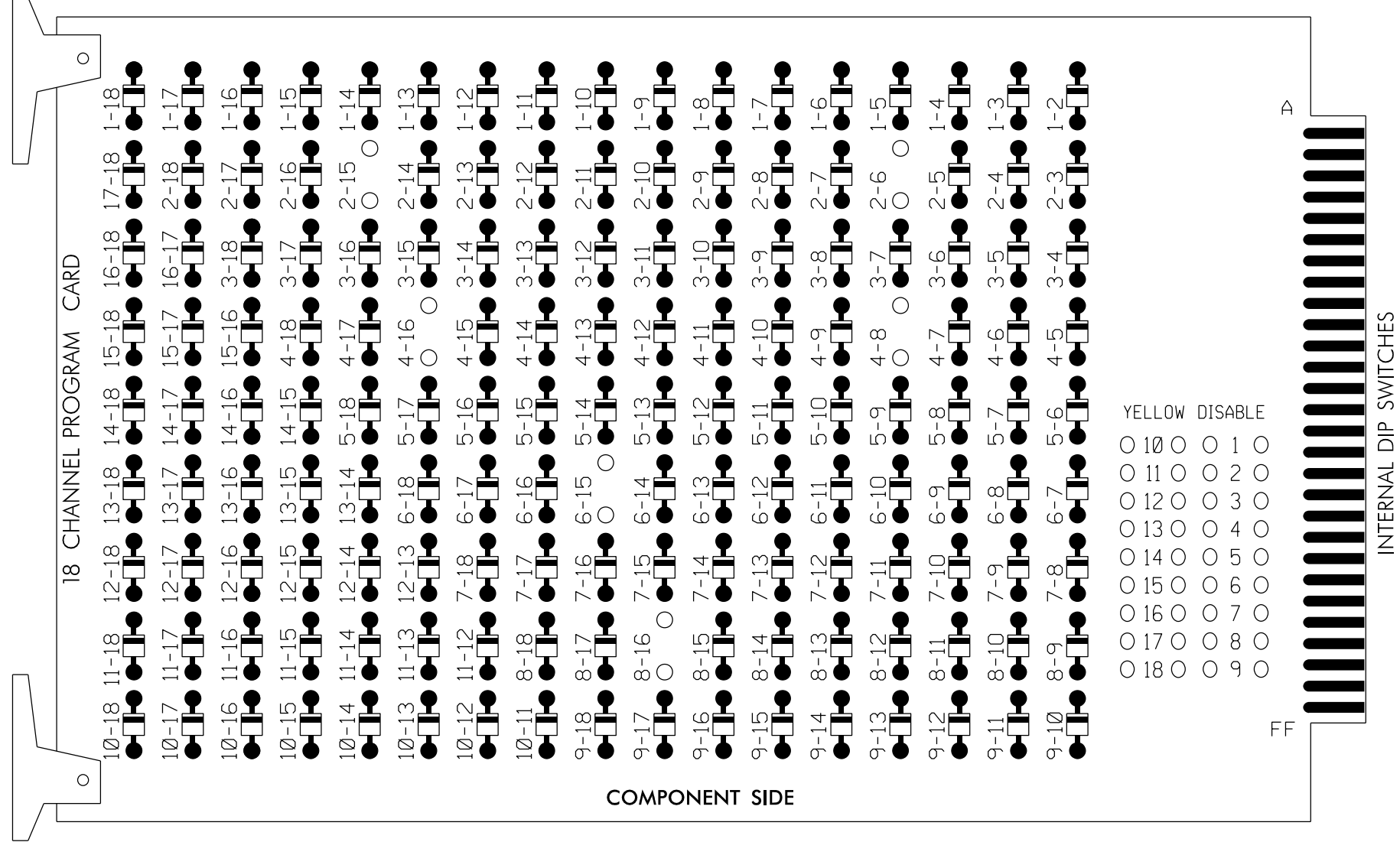

NOTES:

1. Card is provided with all diode jumpers in place. Removal of any jumper allows its channels to run concurrently.
2. Ensure jumpers SEL2-SEL5 and SEL9 are present on the monitor board.
3. Ensure that Red Enable is active at all times during normal operation.
4. Integrate monitor with Ethernet network in cabinet.

REMOVE JUMPERS AS SHOWN

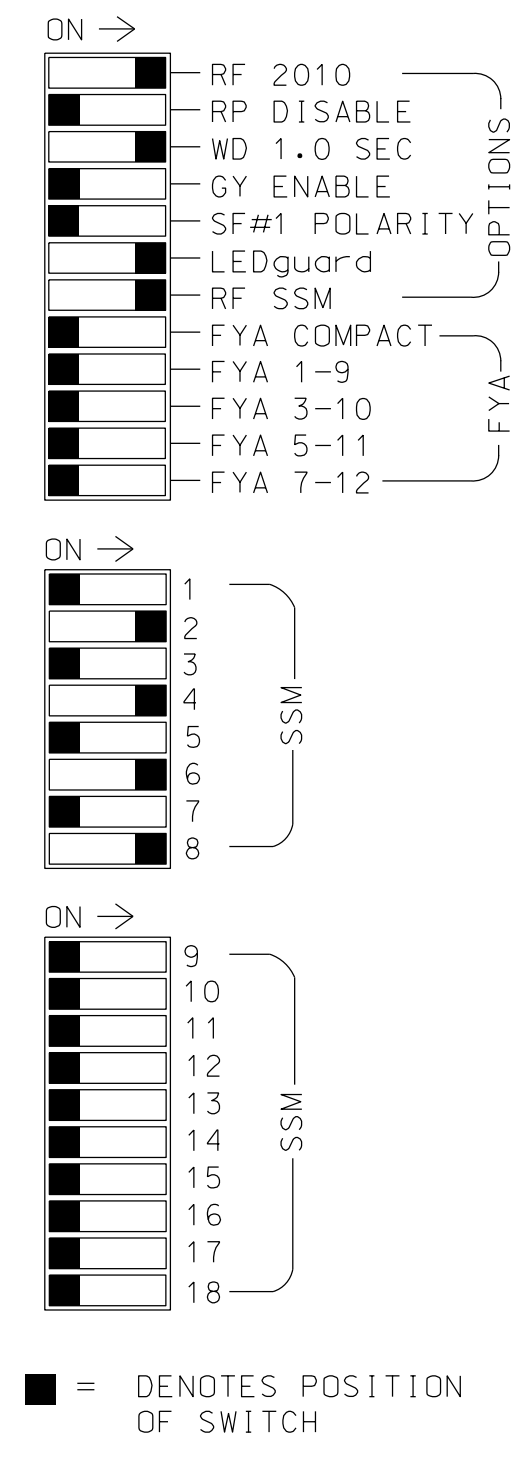

NOTES

1. To prevent "flash-conflict" problems, insert red flash program blocks for all unused vehicle load switches in the output file. The installer shall verify that signal heads flash in accordance with the Signal Plans.
2. Program phases 4 and 8 for Dual Entry.
3. Program controller to start up in phase 2 Green and 6 walk.
4. The cabinet and controller are part of the Burlington-Graham Signal System.

EQUIPMENT INFORMATION

CONTROLLER.....2070LX
 CABINET.....336
 SOFTWARE.....ECONDLITE ASC/3-2070
 CABINET MOUNT.....POLE
 OUTPUT FILE POSITIONS...12
 LOAD SWITCHES USED.....S2,S5,S8,S9,S11,S12
 PHASES USED.....2,4,6,6PED,8,8PED
 OVERLAPS.....NONE

SIGNAL HEAD HOOK-UP CHART

LOAD SWITCH NO.	S1	S2	S3	S4	S5	S6	S7	S8	S9	S10	S11	S12
CMU CHANNEL NO.	1	2	13	3	4	14	5	6	15	7	8	16
PHASE	1	2	2 PED	3	4	4 PED	5	6	6 PED	7	8	8 PED
SIGNAL HEAD NO.	NU	21,22	NU	NU	41,42	NU	NU	61,62	P61, P62	NU	81,82	P81, P82
RED		128			101			134			107	
YELLOW		129			102			135			108	
GREEN		130			103			136			109	
RED ARROW												
YELLOW ARROW												
GREEN ARROW												
Hand icon									119			110
Walking person icon									121			112

NU = Not Used

COUNTDOWN PEDESTRIAN SIGNAL OPERATION

Countdown Ped Signals are required to display timing only during Ped Clearance Interval. Consult Ped Signal Module user's manual for instructions on selecting this feature.

INPUT FILE POSITION LAYOUT

(front view)

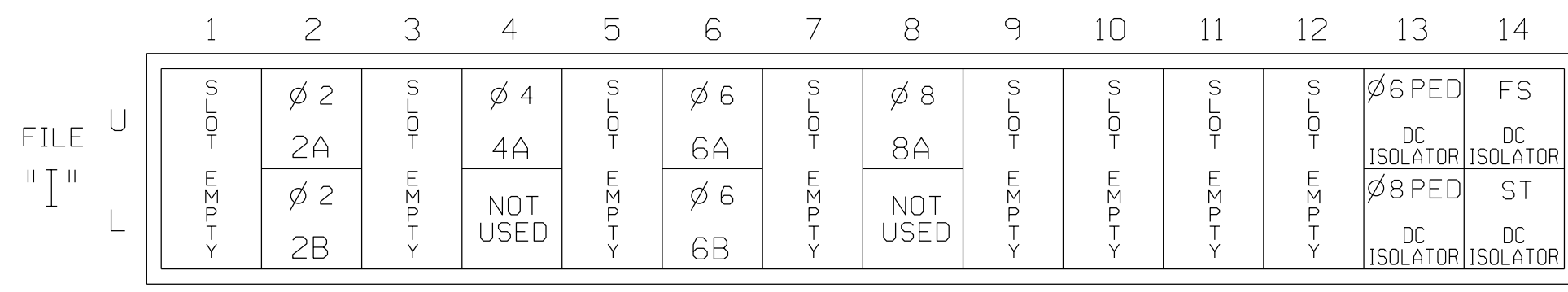

EX.: 1A, 2A, ETC. = LOOP NO.'S

FS = FLASH SENSE
 ST = STOP TIME

INPUT FILE CONNECTION & PROGRAMMING CHART

LOOP NO.	LOOP TERMINAL	INPUT FILE POS.	PIN NO.	DETECTOR NO.	NEMA PHASE	CALL	EXTEND TIME	DELAY TIME	ADDED INITIAL	DETECTOR TYPE
2A	TB21-3,4	I2U	39	2	2	YES				S
2B	TB23-3,4	I2L	43	12	2	YES				S
4A	TB21-7,8	I4U	41	4	4	YES		10		S
6A	TB21-11,12	I6U	40	6	6	YES				S
6B	TB23-11,12	I6L	44	16	6	YES				S
8A	TB22-1,2	I8U	42	8	8	YES		10		S
PED PUSH BUTTONS										
P61,P62	TB22-11,12	I13U	68	PED 6	6 PED					
P81,P82	TB24-11,12	I13L	70	PED 8	8 PED					

NOTE:
 INSTALL DC ISOLATOR IN INPUT FILE SLOT 113.

INPUT FILE POSITION LEGEND: J2L

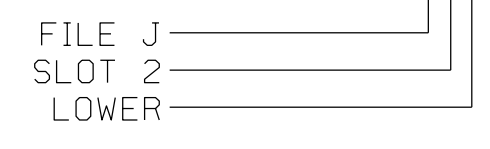

THIS ELECTRICAL DETAIL IS FOR THE SIGNAL DESIGN: 07-1886
 DESIGNED: NOVEMBER 2017
 SEALED: 06-13-2018
 REVISED: N/A

Electrical Detail

Electrical AND PROGRAMMING DETAILS FOR:
 Prepared for the Offices of:

 Plans Prepared By:

 DRMP, Inc.
 8000 Regency Parkway, Suite 175
 Cary, NC 27519
 NC License No. C-2213 (819) 650-1038

SR 1363 (S. Mebane Street) at E. Sixth Street

Division 7 Alamance County Burlington

PLAN DATE: November 2017	REVIEWED BY: AJ Davis
PREPARED BY: RD Lawton	REVIEWED BY: LM Moon
REVISIONS	INIT. DATE

DOCUMENT NOT CONSIDERED FINAL UNLESS ALL SIGNATURES COMPLETED



DocuSigned by:
 Lisa M. Moon 6/13/2018
 DATE
 SIG. INVENTORY NO. 07-1886

PHASING DIAGRAM

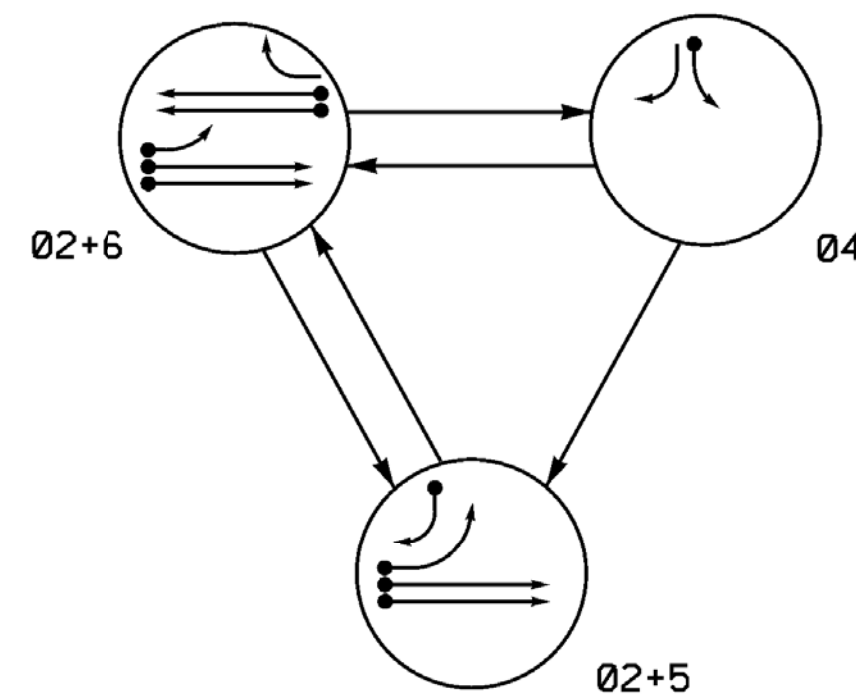

SIGNAL FACE	PHASE			
	02+5	02+6	04	FLASH
21, 22	G	G	R	Y
41	R	R	G	R
42	R	R	G	R
51	R	G	R	Y
61, 62	R	G	R	Y

ASC/3 DETECTOR INSTALLATION CHART												
LOOP	DETECTOR				PROGRAMMING							
	SIZE (FT)	DISTANCE FROM STOPBAR (FT)	TURNS	NEW LOOP	PHASE	CALLING	EXTEND TIME	DELAY TIME	USE ADDED INITIAL	TYPE	SYSTEM LOOP	NEW CARD
2A,2B	6x6	360	EXIST.	-	2	Yes	-	-	X	N	-	X
4A	6x60	0	2-4-2	-	4	Yes	-	3	-	S	-	X
5A	6x60	0	2-4-2	-	5	Yes	-	15	-	S	-	X
5B	6x60	0	2-4-2	-	2	Yes	-	3	-	G	-	X
6A,6B	6x6	360	EXIST.	-	6	Yes	-	-	X	N	-	X

3 Phase Fully Actuated (Burlington-Graham Signal System)

NOTES

1. Refer to "Roadway Standard Drawings NCDOT" dated January 2018 and "Standard Specifications for Roads and Structures" dated January 2018.
2. Do not program signal for late night flashing operation unless otherwise directed by the Engineer.
3. Phase 5 may be lagged.
4. Reposition existing signal head numbered 22.
5. Set all detector units to presence mode.
6. In the event of loop replacement, refer to the current ITS and Signals Design Manual and submit a Plan of Record to the Signal Design Section.
7. Locate new cabinet so as not to obstruct sight distance of vehicles turning right on red.
8. Pavement markings are existing.
9. Maximum times shown in timing chart are for free-run operation only. Coordinated signal system timing values supersede these values.

PHASING DIAGRAM DETECTION LEGEND

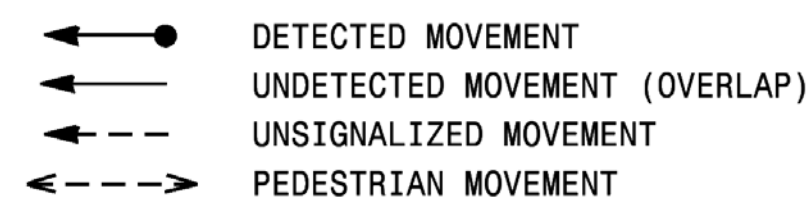

SIGNAL FACE I.D.

All Heads L.E.D.

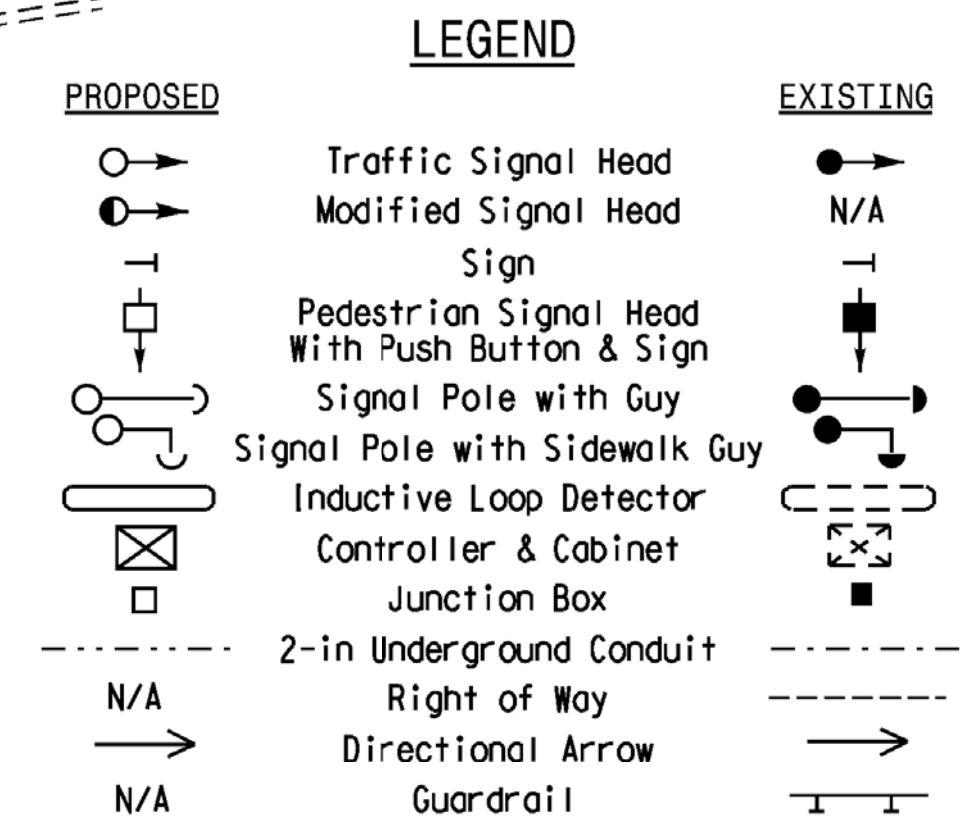
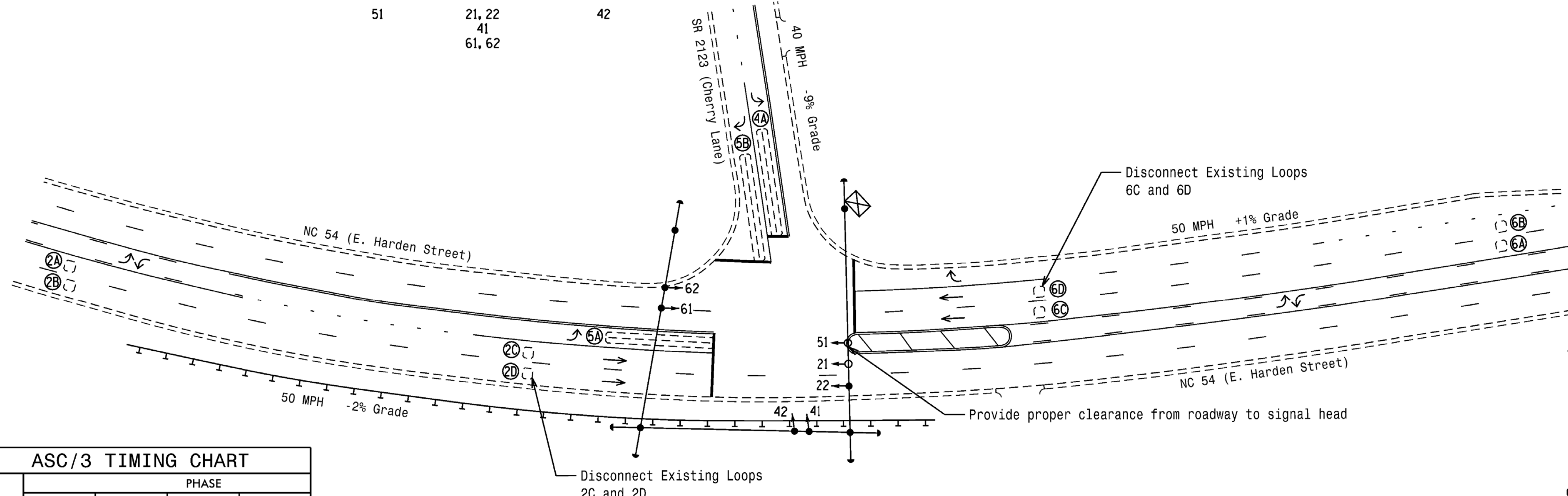
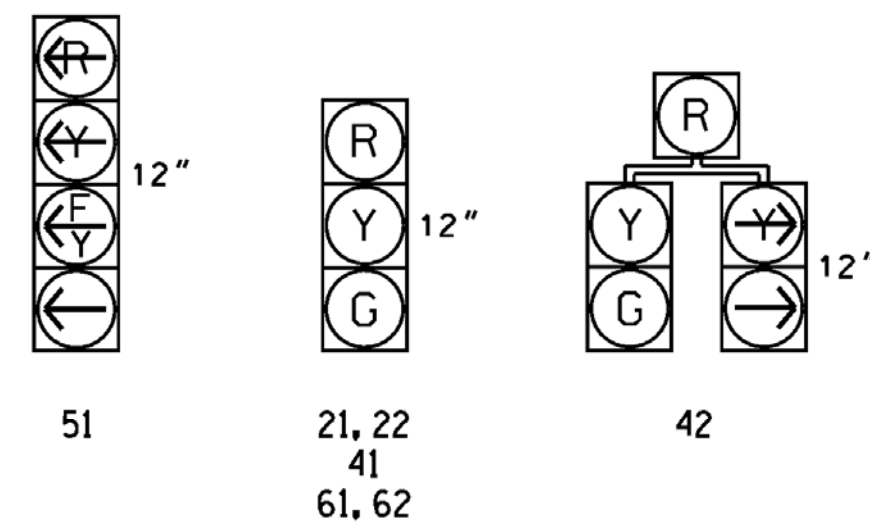

FEATURE	PHASE			
	2	4	5	6
Min Green *	14	7	7	14
Walk *	0	0	0	0
Ped Clear	0	0	0	0
Veh. Extension *	6.0	1.0	1.0	6.0
Max I *	60	25	15	60
Yellow	5.0	3.3	3.0	5.0
Red Clear	1.0	2.6	2.3	1.0
Actuations 34 Add *	0	-	-	0
Seconds /Actuation *	1.5	-	-	1.5
Max Initial *	40	-	-	40
Time Before Reduction *	20	-	-	20
Time To Reduce *	20	-	-	20
Minimum Gap	3.0	-	-	3.0
Locking Detector	X	-	-	X
Recall Position	VEH. RECALL	-	-	VEH. RECALL
Dual Entry	-	-	-	-
Simultaneous Gap	X	X	X	X

* These values may be field adjusted. Do not adjust Min Green and Extension times for phases 2 and 6 lower than what is shown. Min Green for all other phases should not be lower than 4 seconds.



12 BROAD STREET
ASHEVILLE, NORTH CAROLINA 28801
(828) 254-2201
FAX (828) 254-4562
NC LIC. NO. C-1154

Signal Upgrade

	Prepared for the Offices of: NC 54 (E. Harden Street) at SR 2123 (Cherry Lane)		SEAL JAMES B. VOSO ENGINEER 022599 6/13/2018
	Division 7 Alamance County Burlington PLAN DATE: September 2017 REVIEWED BY: JB Voso PREPARED BY: SE Wilson REVIEWED BY:	REVISIONS INIT. DATE	
DOCUMENT NOT CONSIDERED FINAL UNLESS ALL SIGNATURES COMPLETED			SIG. INVENTORY NO. 07-1938

*****SYTIME*****
*****BUSINESS*****

EDI MODEL 2018ECLIP-NC CONFLICT MONITOR
PROGRAMMING DETAIL

(remove jumpers and set switches as shown)

REMOVE DIODE JUMPERS 2-5, 2-6, 2-11, 5-11 and 6-11.

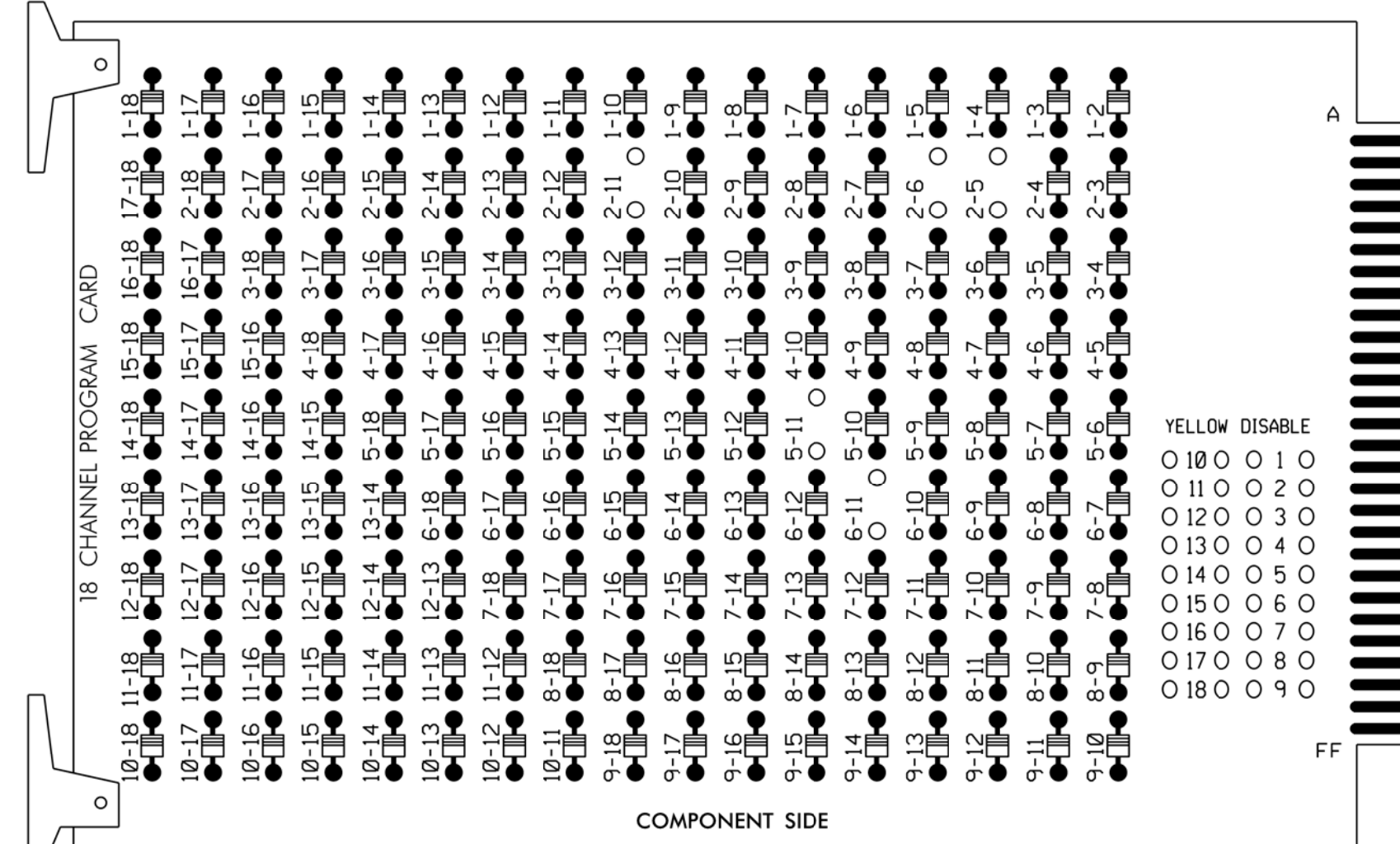

REMOVE JUMPERS AS SHOWN

NOTES:

1. Card is provided with all diode jumpers in place. Removal of any jumper allows its channels to run concurrently.
2. Ensure jumpers SEL2-SEL5 and SEL9 are present on the monitor board.
3. Ensure that Red Enable is active at all times during normal operation.
4. Integrate monitor with Ethernet network in cabinet.

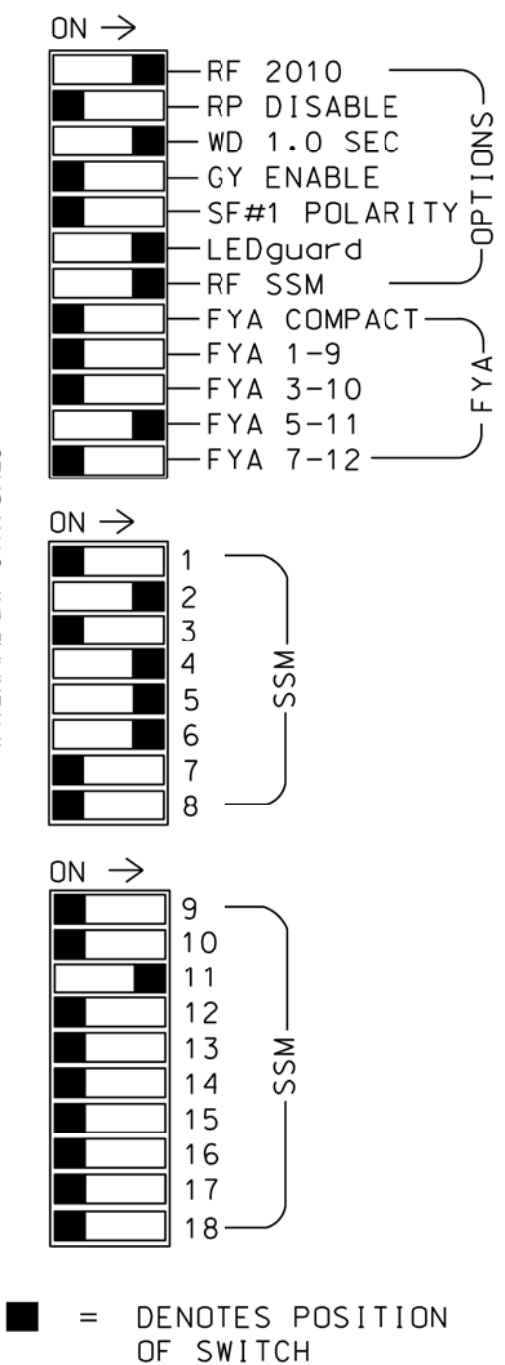
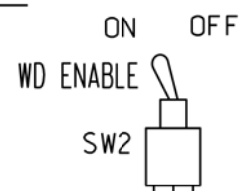

■ = DENOTES POSITION OF SWITCH

NOTES

1. To prevent "flash-conflict" problems, insert red flash program blocks for all unused vehicle load switches in the output file. The installer shall verify that signal heads flash in accordance with the Signal Plans.
2. Program controller to start up in phase 2 Green and 6 Green.
3. The cabinet and controller are part of the Burlington-Graham Signal System.

SIGNAL HEAD HOOK-UP CHART

LOAD SWITCH NO.	S1	S2	S3	S4	S5	S6	S7	S8	S9	S10	S11	S12	AUX S1	AUX S2	AUX S3	AUX S4	AUX S5	AUX S6
CMU CHANNEL NO.	1	2	13	3	4	14	5	6	15	7	8	16	9	10	17	11	12	18
PHASE	1	2	2 PED	3	4	4 PED	5	6	6 PED	7	8	8 PED	OLA	OLB	SPARE	OLC	OLD	SPARE
SIGNAL HEAD NO.	NU	21,22	NU	NU	41,42	NU	42	51	61,62	NU	NU	NU	NU	NU	NU	51	NU	NU
RED		128			101		*		134									
YELLOW		129			102				135									
GREEN		130			103				136									
RED ARROW																		A114
YELLOW ARROW								132										A115
FLASHING YELLOW GREEN																		A116
GREEN ARROW								133	133									

NU = Not Used
* Denotes install load resistor. See load resistor installation detail this sheet.
★ See pictorial of head wiring in detail below.

EQUIPMENT INFORMATION

CONTROLLER.....2070LX
CABINET.....332 /W/ AUX
SOFTWARE.....ECONOLITE ASC/3-2070
CABINET MOUNT.....BASE
OUTPUT FILE POSITIONS..18 WITH AUX. OUTPUT FILE
LOAD SWITCHES USED.....S2,S5,S7,S8,AUXS4
PHASES USED.....2,4,5,6
OVERLAP "A".....NOT USED
OVERLAP "B".....NOT USED
OVERLAP "C".....*
OVERLAP "D".....NOT USED
* See overlap programming detail on sheet 2

INPUT FILE POSITION LAYOUT

(front view)

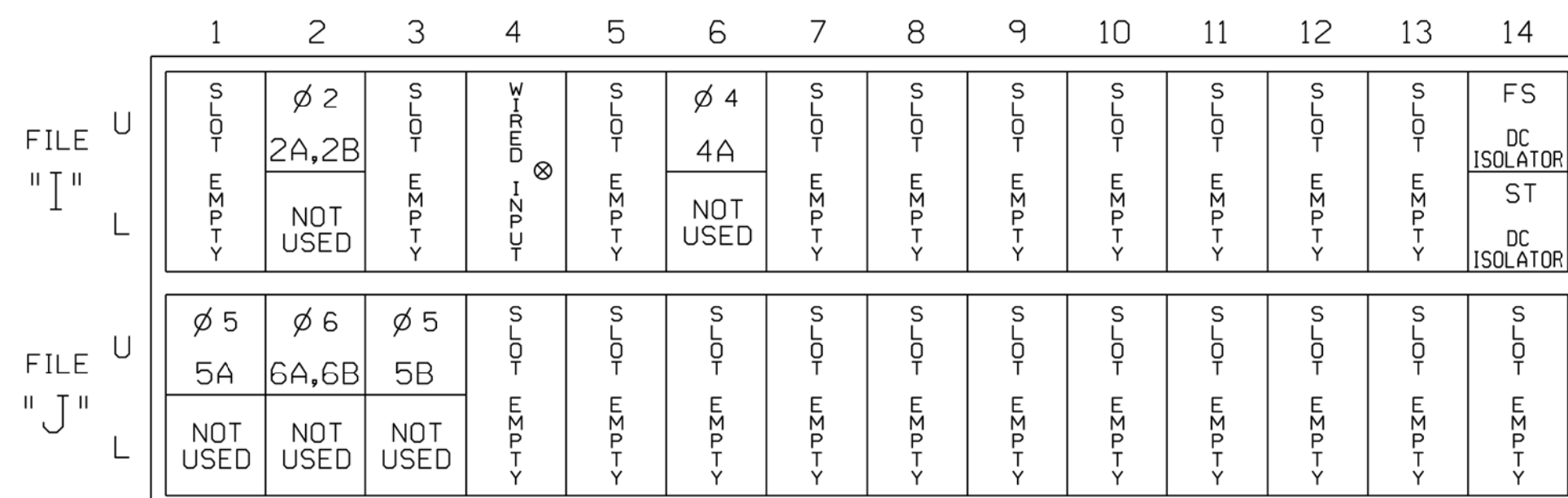

EX.: 1A, 2A, ETC. = LOOP NO.'S

FS = FLASH SENSE
ST = STOP TIME

LOAD RESISTOR INSTALLATION DETAIL

(install resistors as shown)

VALUE (ohms)	WATTAGE
1.5K - 1.9K	25W (min)
2.0K - 3.0K	10W (min)

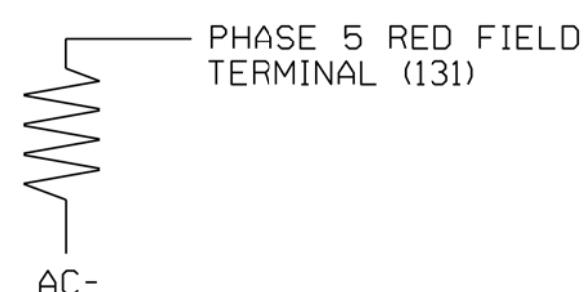

FYA SIGNAL WIRING DETAIL

(wire signal head as shown)

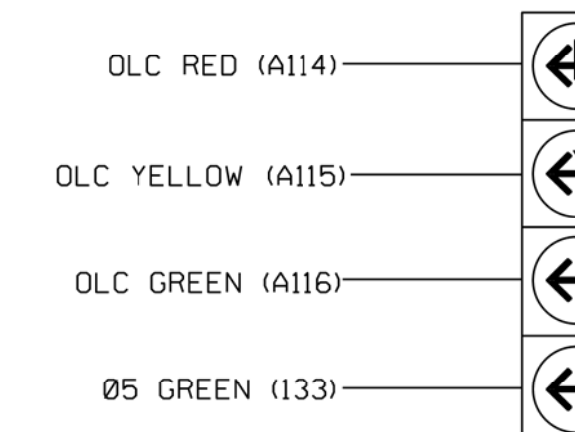

51

INPUT FILE CONNECTION & PROGRAMMING CHART

LOOP NO.	LOOP TERMINAL	INPUT FILE POS.	PIN NO.	DETECTOR NO.	NEMA PHASE	CALL	EXTEND TIME	DELAY TIME	ADDED INITIAL	DETECTOR TYPE
2A,2B	TB2-5,6	I2U	39	2	2	YES			X	N
4A	TB4-9,10	I6U	41	4	4	YES		3		S
5A ¹	TB3-1,2	J1U	55	5	5	YES		15		S
		14U	47	22	2	YES		3		G
6A,6B	TB3-5,6	J2U	40	6	6	YES			X	N
5B	TB3-9,10	J3U	64	36	5	YES		15		S

¹Add jumper from J1-W to 14-W, on rear of input file.

INPUT FILE POSITION LEGEND: J2L

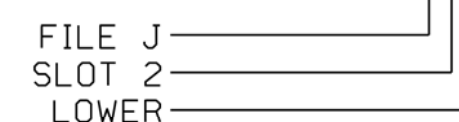

Electrical Detail - Sheet 1 of 2



12 BROAD STREET
ASHEVILLE, NORTH CAROLINA 28801
(828) 254-2201
FAX (828) 254-4562
NC LIC. NO. C-1154

ELECTRICAL AND PROGRAMMING DETAILS FOR:

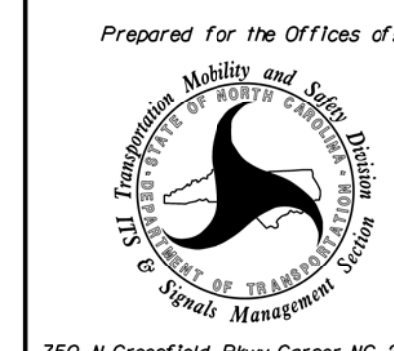

NC 54 (E. Harden Street)
at
SR 2123 (Cherry Lane)

Division 7 Alamance County Burlington

PLAN DATE: September 2017 REVIEWED BY: JB Vosso

PREPARED BY: SE Wilson REVIEWED BY:

REVISIONS INIT. DATE

SIGNATURE DATE

DOCUMENT NOT CONSIDERED FINAL UNLESS ALL SIGNATURES COMPLETED

SEAL
JAMES B. VOSSO
PROFESSIONAL ENGINEER
STATE OF NORTH CAROLINA
SEAL 022599
6/13/2018
DATE

SIG. INVENTORY NO. 07-1938

ECONOLITE ASC/3-2070 OVERLAP PROGRAMMING DETAIL

(program controller as shown below)

1. From Main Menu select 2. CONTROLLER
1. From CONTROLLER Submenu select 2. VEHICLE OVERLAPS
- Toggle Twice

OVERLAP C
Select TMG VEH OVLP [C] and 'PPLT FYA'

TMG VEH OVLP...[C] TYPE:		PPLT FYA
PROTECTED LEFT TURN....	PHASE	5
OPPOSING THROUGH.....	PHASE	6
FLASHING ARROW OUTPUT.....CH11 ISOLATE		
DELAY START OF: FYA..0.0 CLEARANCE..0.0		
ACTION PLAN SF BIT DISABLE..... 0		

END PROGRAMMING

THIS ELECTRICAL DETAIL IS FOR
THE SIGNAL DESIGN: 07-1938
DESIGNED: September 2017
SEALED: 6/13/2018
REVISED: NA

Electrical Detail - Sheet 2 of 2



12 BROAD STREET
ASHEVILLE, NORTH CAROLINA 28801
(828) 254-2201
FAX (828) 254-4562
NC LIC. NO. C-1154

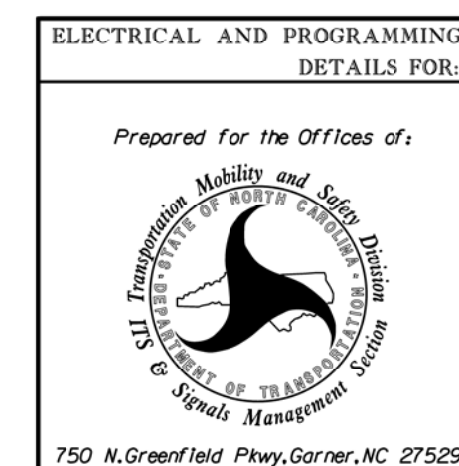

ELECTRICAL AND PROGRAMMING DETAILS FOR:		NC 54 (E. Harden Street) at SR 2123 (Cherry Lane)	
Prepared for the Offices of:		Division 7 Alamance County Burlington	
PLAN DATE: September 2017	REVIEWED BY: JB Voso		
PREPARED BY: SE Wilson	REVIEWED BY:		
REVISIONS	INIT.	DATE	

DOCUMENT NOT CONSIDERED
FINAL UNLESS ALL
SIGNATURES COMPLETED

SEAL
James Voso
6/13/2018
SIGNATURE DATE
SIG. INVENTORY NO. 07-1938

*****SYTIME*****
 *****DOCS*****
 *****SERIAL*****

PHASING DIAGRAM

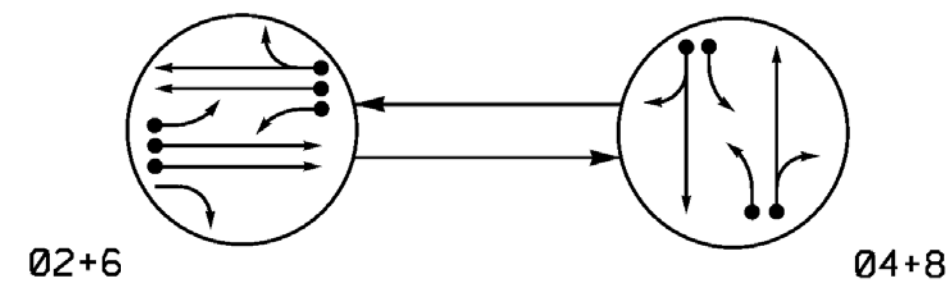

PHASING DIAGRAM DETECTION LEGEND
 ● DETECTED MOVEMENT
 ○ UNDETECTED MOVEMENT (OVERLAP)
 - - - UNSIGNALIZED MOVEMENT
 - - - PEDESTRIAN MOVEMENT

SIGNAL FACE	PHASE		
	02+6	04+8	FLASH
21, 22, 23	G	R	Y
41, 42	R	G	R
61, 62	G	R	Y
81, 82	R	G	R

SIGNAL FACE I.D.
 All Heads L.E.D.

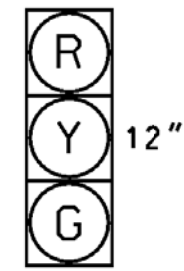

21, 22, 23
 41, 42
 61, 62
 81, 82

ASC/3 DETECTOR INSTALLATION CHART										
DETECTOR					PROGRAMMING					
LOOP	SIZE (FT)	DISTANCE FROM STOPBAR (FT)	TURNS	NEW LOOP	PHASE	CALLING	EXTEND TIME	DELAY TIME	USE ADDED INITIAL	TYPE
2A,2B	6x6	300	EXIST.	-	2	Yes	-	-	X	N - X
2C	6x60	0	2-4-2	-	2	Yes	-	3	-	G - X
4A	6x60	0	2-4-2	-	4	Yes	-	3	-	S - X
4B	6x60	0	2-4-2	-	4	Yes	-	10	-	S - X
6A,6B	6x6	300	EXIST.	-	6	Yes	-	-	X	N - X
6C	6x60	0	2-4-2	-	6	Yes	-	3	-	G - X
8A	6x60	0	2-4-2	-	8	Yes	-	3	-	S - X
8B	6x40	0	2-4-2	-	8	Yes	-	10	-	S - X
8C	6x6	0	EXIST.	-	8	Yes	-	15	-	S - X

2 Phase
 Fully Actuated
 (Burlington-Graham Signal System)

NOTES

1. Refer to "Roadway Standard Drawings NCDOT" dated January 2018 and "Standard Specifications for Roads and Structures" dated January 2018.
2. Do not program signal for late night flashing operation unless otherwise directed by the Engineer.
3. Set all detector units to presence mode.
4. In the event of loop replacement, refer to the current ITS and Signals Design Manual and submit a Plan of Record to the Signal Design Section.
5. Locate new cabinet so as not to obstruct sight distance of vehicles turning right on red.
6. The cabinet should be designed to include an Auxiliary Output file for future use.
7. Pavement markings are existing.
8. Maximum times shown in timing chart are for free-run operation only. Coordinated signal system timing values supersede these values.

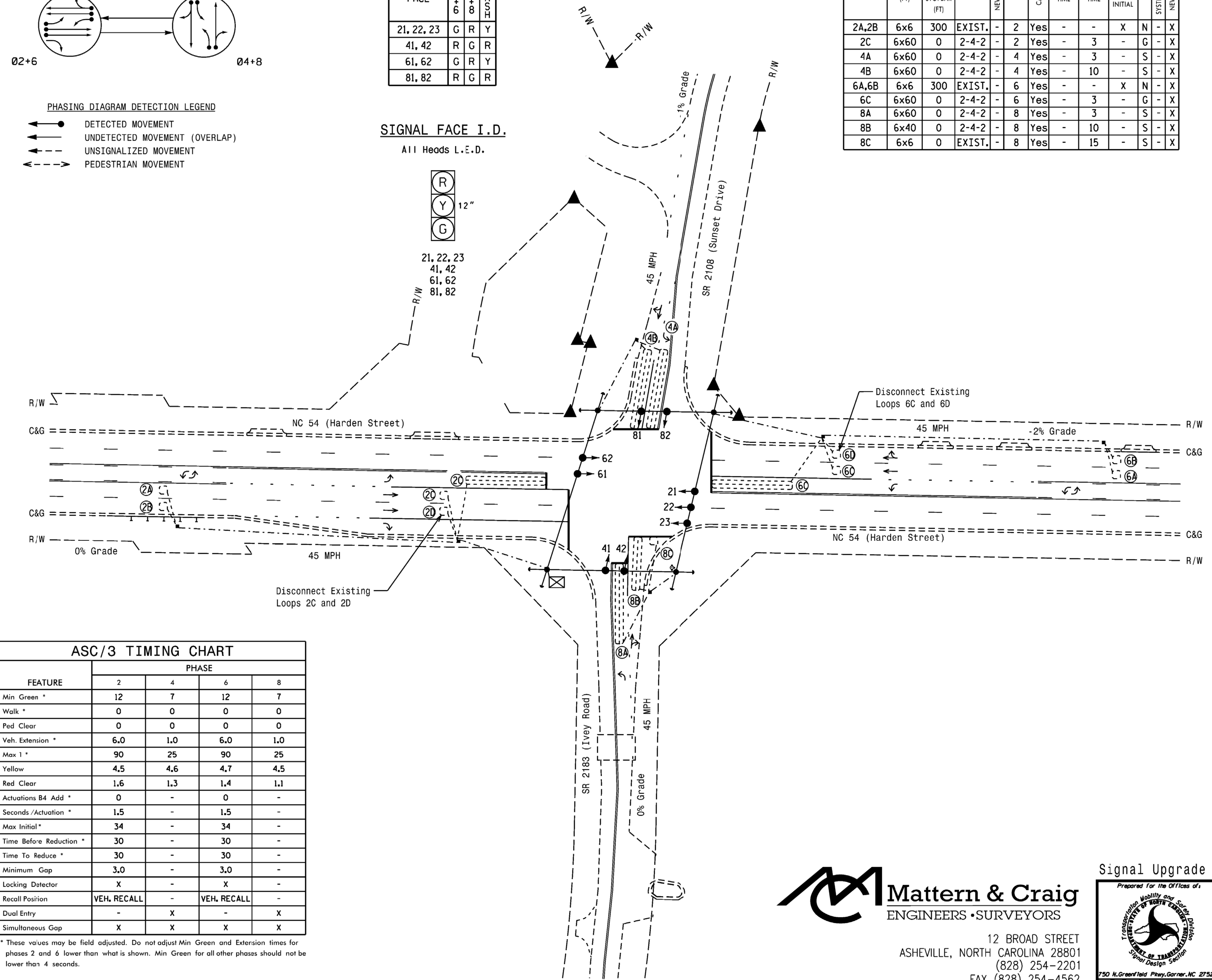

ASC/3 TIMING CHART

FEATURE	PHASE			
	2	4	6	8
Min Green *	12	7	12	7
Walk *	0	0	0	0
Ped Clear	0	0	0	0
Veh. Extension *	6.0	1.0	6.0	1.0
Max I *	90	25	90	25
Yellow	4.5	4.6	4.7	4.5
Red Clear	1.6	1.3	1.4	1.1
Actuations B4 Add *	0	-	0	-
Seconds / Actuation *	1.5	-	1.5	-
Max Initial *	34	-	34	-
Time Before Reduction *	30	-	30	-
Time To Reduce *	30	-	30	-
Minimum Gap	3.0	-	3.0	-
Locking Detector	X	-	X	-
Recall Position	VEH. RECALL	-	VEH. RECALL	-
Dual Entry	-	X	-	X
Simultaneous Gap	X	X	X	X

* These values may be field adjusted. Do not adjust Min Green and Extension times for phases 2 and 6 lower than what is shown. Min Green for all other phasas should not be lower than 4 seconds.

PROPOSED		EXISTING	
○	Traffic Signal Head	●	N/A
○	Modified Signal Head		
⊥	Sign	⊥	
⊥	Pedestrian Signal Head With Push Button & Sign	⊥	
⊥	Signal Pole with Guy	⊥	
⊥	Signal Pole with Sidewalk Guy	⊥	
⊥	Inductive Loop Detector	⊥	
⊥	Controller & Cabinet	⊥	
⊥	Junction Box	⊥	
⊥	2-in Underground Conduit	⊥	
N/A	Right of Way	▲	
→	Directional Arrow	→	

Mattern & Craig
 ENGINEERS • SURVEYORS

12 BROAD STREET
 ASHEVILLE, NORTH CAROLINA 28801
 (828) 254-2201
 FAX (828) 254-4562
 NC LIC. NO. C-1154

Signal Upgrade

Prepared for the Offices of:

 750 N. Greenfield Pkwy, Garner, NC 27529
 SCALE: 0 40
 1" = 40'

DOCUMENT NOT CONSIDERED FINAL UNLESS ALL SIGNATURES COMPLETED

NC 54 (Harden Street)
 at
 SR 2108 (Sunset Drive)
 / SR 2183 (Ivey Road)
 Division 7 Alamance County Graham

PLAN DATE: September 2017 REVIEWED BY: JB Voso
 PREPARED BY: SE Wilson REVIEWED BY:

REVISIONS: _____ INIT. DATE

SEAL 022599
 JAMES B. VOSO
 ENGINEER
 6/13/2018
 SIG. INVENTORY NO. 07-1939

*****SYSTEM *****
 *****USER *****

EDI MODEL 2018ECLip-NC CONFLICT MONITOR
PROGRAMMING DETAIL
(remove jumpers and set switches as shown)

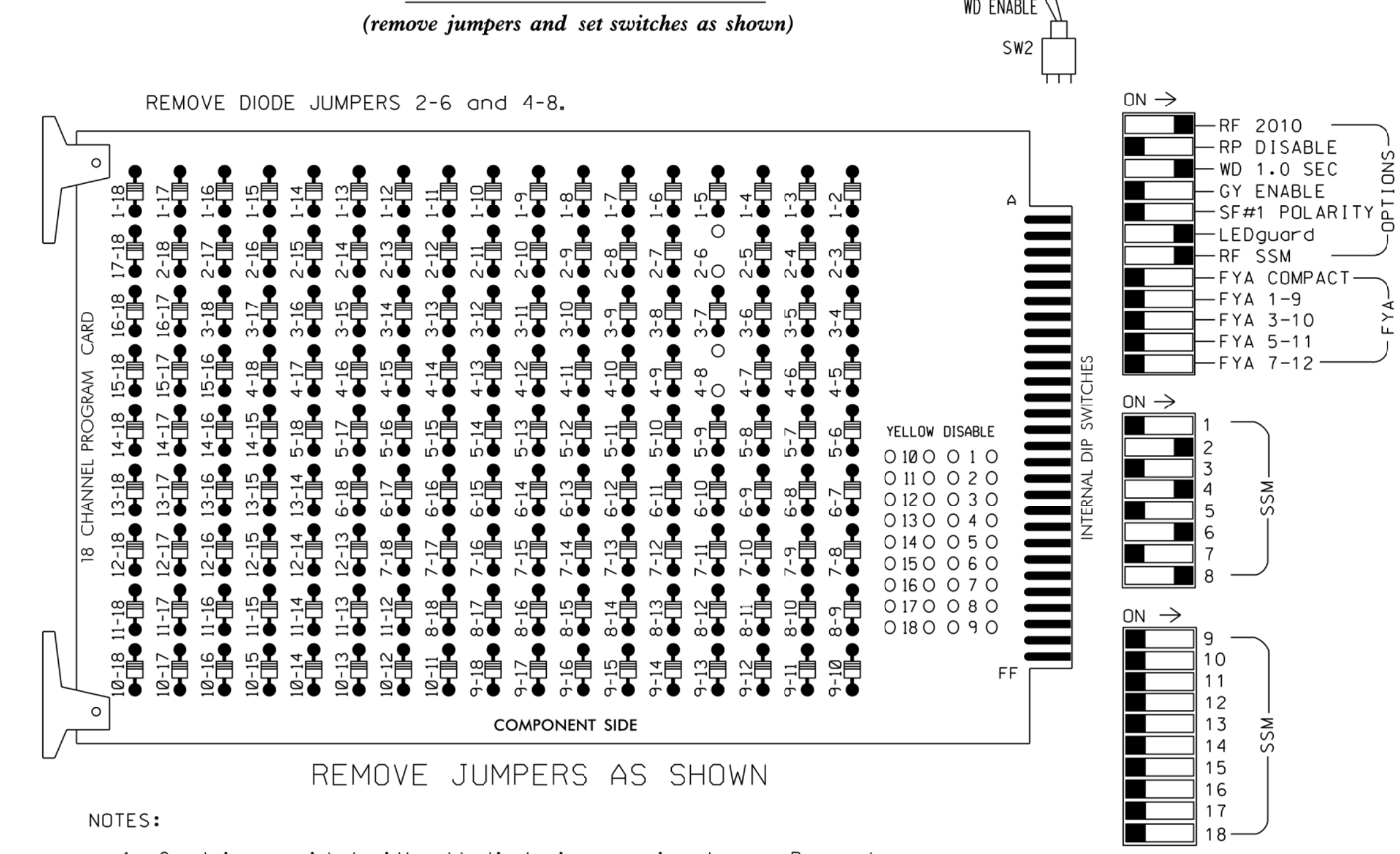

- NOTES:
1. Card is provided with all diode jumpers in place. Removal of any jumper allows its channels to run concurrently.
 2. Ensure jumpers SEL2-SEL5 and SEL9 are present on the monitor board.
 3. Ensure that Red Enable is active at all times during normal operation.
 4. Integrate monitor with Ethernet network in cabinet.

NOTES

1. To prevent "flash-conflict" problems, insert red flash program blocks for all unused vehicle load switches in the output file. The installer shall verify that signal heads flash in accordance with the Signal Plans.
2. Program phases 4 and 8 for Dual Entry.
3. Program controller to start up in phase 2 Green and 6 Green.
4. The cabinet and controller are part of the Burlington-Graham Signal System.

SIGNAL HEAD HOOK-UP CHART

LOAD SWITCH NO.	S1	S2	S3	S4	S5	S6	S7	S8	S9	S10	S11	S12	AUX S1	AUX S2	AUX S3	AUX S4	AUX S5	AUX S6
CMU CHANNEL NO.	1	2	13	3	4	14	5	6	15	7	8	16	9	10	17	11	12	18
PHASE	1	2	2 PED	3	4	4 PED	5	6	6 PED	7	8	8 PED	OLA	OLB	SPARE	OLC	OLD	SPARE
SIGNAL HEAD NO.	NU	21,22 23	NU	NU	41,42	NU	NU	61,62	NU	NU	81,82	NU	NU	NU	NU	NU	NU	NU
RED		128			101			134			107							
YELLOW		129			102			135			108							
GREEN		130			103			136			109							
RED ARROW																		
YELLOW ARROW																		
GREEN ARROW																		

NU = Not Used

EQUIPMENT INFORMATION

CONTROLLER.....2070LX
 CABINET.....332 /W/ AUX
 SOFTWARE.....ECONOLITE ASC/3-2070
 CABINET MOUNT.....BASE
 OUTPUT FILE POSITIONS...18 WITH AUX. OUTPUT FILE
 LOAD SWITCHES USED.....S2,S5,S8,S11
 PHASES USED.....2,4,6,8
 OVERLAP "A".....NOT USED
 OVERLAP "B".....NOT USED
 OVERLAP "C".....NOT USED
 OVERLAP "D".....NOT USED

INPUT FILE POSITION LAYOUT
(front view)

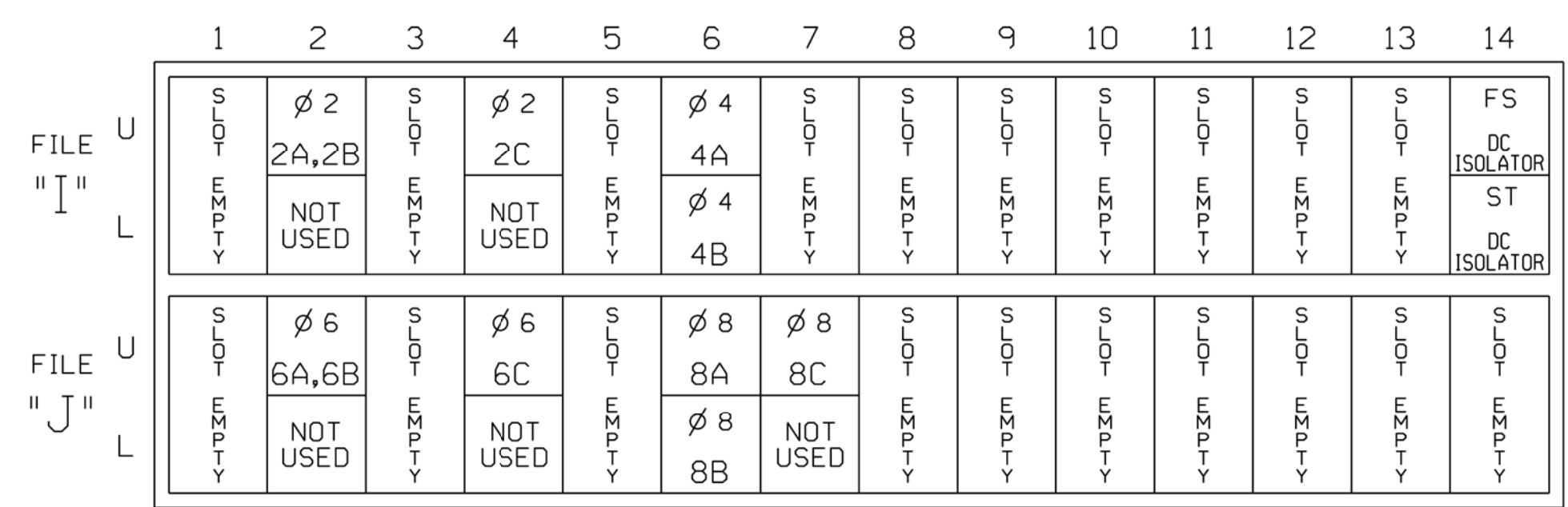

EX. : 1A, 2A, ETC. = LOOP NO.'S
 FS = FLASH SENSE
 ST = STOP TIME

INPUT FILE CONNECTION & PROGRAMMING CHART

LOOP NO.	LOOP TERMINAL	INPUT FILE POS.	PIN NO.	DETECTOR NO.	NEMA PHASE	CALL	EXTEND TIME	DELAY TIME	ADDED INITIAL	DETECTOR TYPE
2A,2B	TB2-5,6	I2U	39	2	2	YES			X	N
2C	TB4-1,2	I4U	47	22	2	YES		3		G
4A	TB4-9,10	I6U	41	4	4	YES		3		S
4B	TB4-11,12	I6L	45	14	4	YES		10		S
6A,6B	TB3-5,6	J2U	40	6	6	YES			X	N
6C	TB5-1,2	J4U	48	26	6	YES		3		G
8A	TB5-9,10	J6U	42	8	8	YES		3		S
8B	TB5-11,12	J6L	46	18	8	YES		10		S
8C	TB7-1,2	J7U	66	38	8	YES		15		S

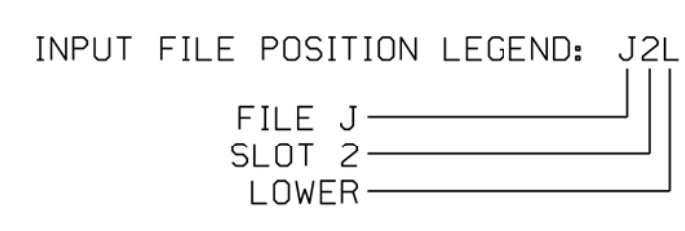

THIS ELECTRICAL DETAIL IS FOR THE SIGNAL DESIGN: 07-1939
 DESIGNED: September 2017
 SEALED: 6/13/2018
 REVISED: NA

*****SYTIME*****



12 BROAD STREET
 ASHEVILLE, NORTH CAROLINA 28801
 (828) 254-2201
 FAX (828) 254-4562
 NC LIC. NO. C-1154

Electrical Detail

ELECTRICAL AND PROGRAMMING DETAILS FOR:



NC 54 (Harden Street)
 at
 SR 2108 (Sunset Drive)
 / SR 2183 (Ivey Road)

Division 7	Alamance County	Graham
PLAN DATE: September 2017	REVIEWED BY: JB Voso	
PREPARED BY: SE Wilson	REVIEWED BY:	
REVISIONS	INIT.	DATE

DOCUMENT NOT CONSIDERED FINAL UNLESS ALL SIGNATURES COMPLETED

SEAL
 NORTH CAROLINA PROFESSIONAL ENGINEER
 JAMES B. VOSO
 SEAL 022599
 James Voso
 6/13/2018
 SIGNATURE DATE
 SIG. INVENTORY NO. 07-1939

PHASING DIAGRAM

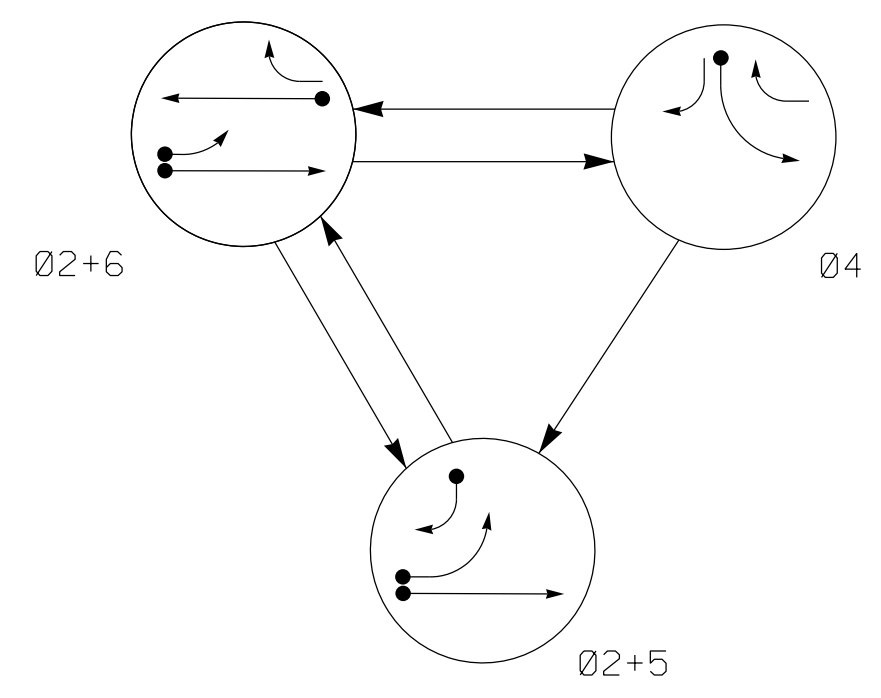

PHASING DIAGRAM DETECTION LEGEND

- DETECTED MOVEMENT
- ◄ UNDETECTED MOVEMENT (OVERLAP)
- ◄ UNSIGNALIZED MOVEMENT
- ◄ PEDESTRIAN MOVEMENT

SIGNAL FACE	PHASE			
	2	4	5	6
21,22	G	G	R	Y
41	R	R	G	R
42	R	R	G	R
51	—	—	—	—
61	R	G	R	Y
62	R	G	R	Y

SIGNAL FACE I.D.

All Heads L.E.D.

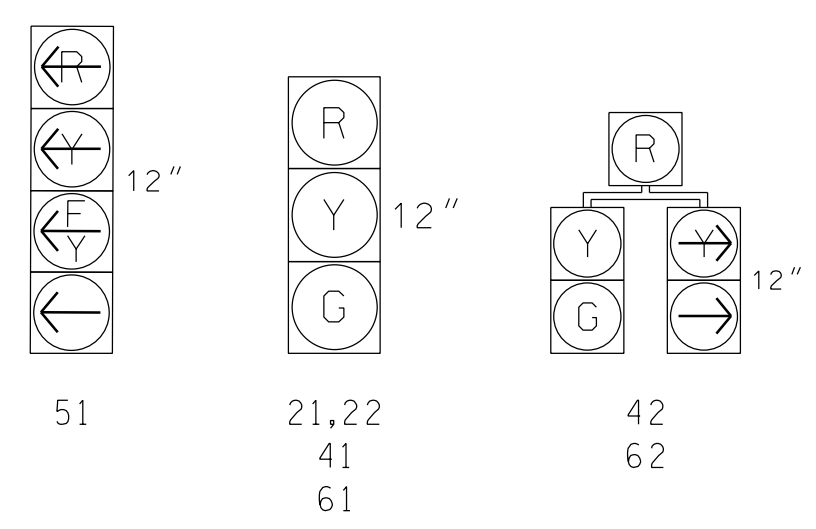

ASC/3 DETECTOR INSTALLATION CHART												
LOOP	SIZE (FT)	DISTANCE FROM STOPBAR (FT)	TURNS	NEW LOOP	PHASE	PROGRAMMING						
						CALLING	EXTEND TIME	DELAY TIME	USE ADDED INITIAL	TYPE	SYSTEM LOOP	NEW CARD
2A	6X6	300	EXIST	-	2	Yes	-	-	X	N	-	X
4A	6X40	0	2-4-2	-	4	Yes	-	3	-	S	-	X
5A	6X40	0	2-4-2	-	5	Yes	-	15	-	S	-	X
5B	6X40	0	2-4-2	-	5	Yes	-	10	-	S	-	X
5C	6X15	0	EXIST	-	5	Yes	-	15	-	S	-	X
6A	6X6	300	EXIST	-	6	Yes	-	-	X	N	-	X
S1	6X6	+140	4	X	-	No	-	-	-	N	X	X

3 Phase Fully Actuated (Burlington-Graham Signal System)

NOTES

1. Refer to "Roadway Standard Drawings NCDOT" dated January 2018 and "Standard Specifications for Roads and Structures" dated January 2018.
2. Do not program signal for late night flashing operation unless otherwise directed by the Engineer.
3. Phase 5 may be lagged.
4. Reposition existing signal head numbered 22.
5. Set all detector units to presence mode.
6. In the event of loop replacement, refer to the current ITS and Signals Design Manual and submit a Plan of Record to the Signal Design Section.
7. Locate new cabinet so as to obstruct sight distances of vehicles turning right on red.
8. Pavement markings are existing.
9. Maximum times shown in timing chart are for free-run operation only. Coordinated signal system timing values supersede these values.

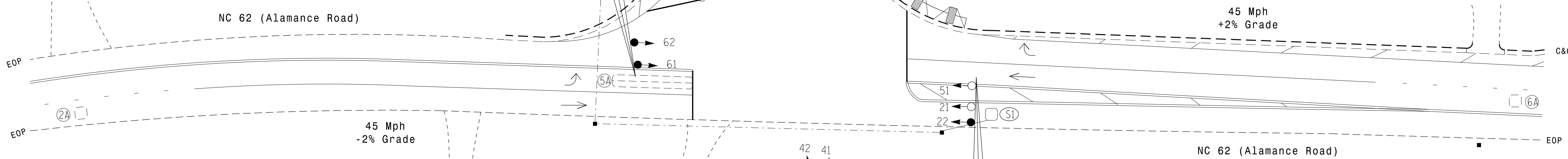

FEATURE	PHASE			
	2	4	5	6
Min Green *	12	7	7	12
Walk *	0	0	0	0
Ped Clear	0	0	0	0
Veh. Extension *	6.0	2.0	2.0	6.0
Max 1 *	90	30	45	90
Yellow	4.7	3.0	3.0	4.7
Red Clear	1.6	3.2	2.4	1.6
Actuations B4 Add *	0	-	-	0
Seconds / Actuation *	2.5	-	-	2.5
Max Initial *	34	-	-	34
Time Before Reduction *	15	-	-	15
Time To Reduce *	45	-	-	45
Minimum Gap	3.0	-	-	3.0
Locking Detector	X	-	-	X
Recall Position	VEH. RECALL	-	-	VEH. RECALL
Dual Entry	-	-	-	-
Simultaneous Gap	X	X	X	X

* These values may be field adjusted. Do not adjust Min Green and Extension times for phases 2 and 6 lower than what is shown. Min Green for all other phases should not be lower than 4 seconds.

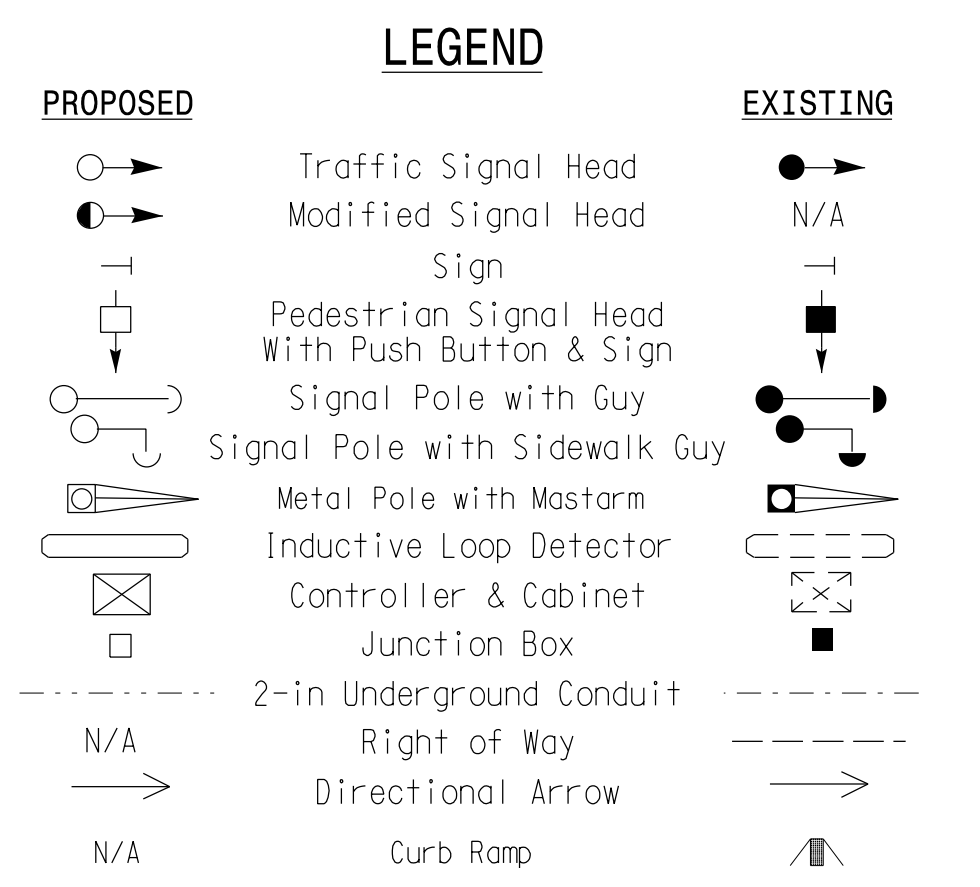

Signal Upgrade

Prepared for the Offices of:

 750 N. Greenfield Pkwy, Garner, NC 27529
 SCALE: 0 30 1"=30'

NC 62 (Alamance Road) at SR 1213 (Grand Oaks Boulevard)

Division 7 Alamance County Burlington

PLAN DATE: November 2017 REVIEWED BY: AM Encarnacion

PREPARED BY: NA Ptak REVIEWED BY: PL Alexander

REVISIONS	INIT.	DATE

DOCUMENT NOT CONSIDERED FINAL UNLESS ALL SIGNATURES COMPLETED

SEAL
 NORTH CAROLINA PROFESSIONAL ENGINEER
 023489
 PAMELA L. ALEXANDER
 6/7/2018
 SIGNATURE
 SIG. INVENTORY NO. 07-1990

07-JUN-2018 11:15
 D:\Transpor\at\work\Facility\cur\00056469 U-6015 B-G S19 Syste\Task 05_11_Signal\Des\gsm07-1990.dgn
 ALEX3361 AT LUS3361

EDI MODEL 2018ECLip-NC CONFLICT MONITOR PROGRAMMING DETAIL

(remove jumpers and set switches as shown)

REMOVE DIODE JUMPERS 2-5, 2-6, 2-11, 5-11, and 6-11.

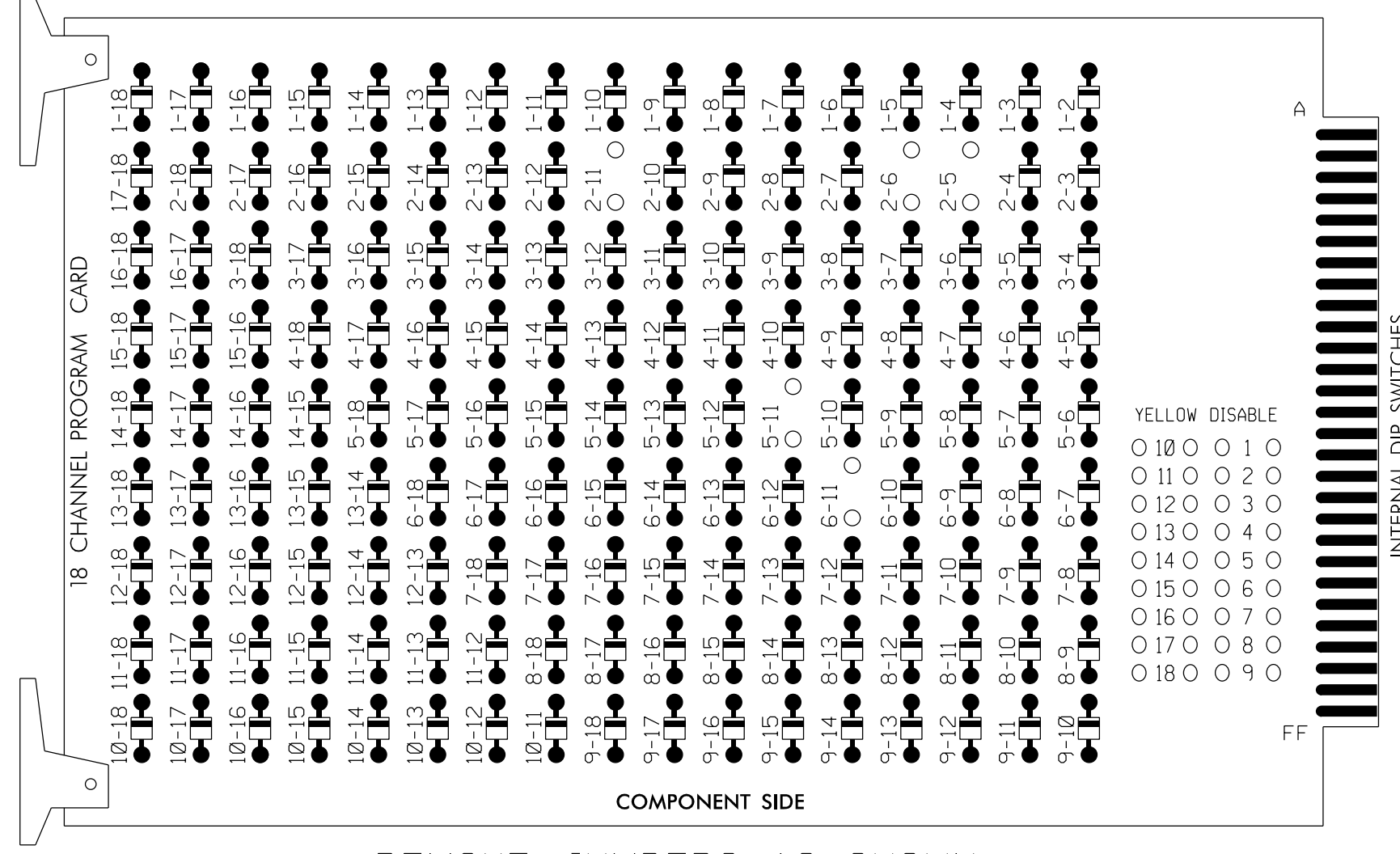

REMOVE JUMPERS AS SHOWN

NOTES:

1. Card is provided with all diode jumpers in place. Removal of any jumper allows its channels to run concurrently.
2. Ensure jumpers SEL2-SEL5 and SEL9 are present on the monitor board.
3. Ensure that Red Enable is active at all times during normal operation.
4. Integrate monitor with Ethernet network in cabinet.

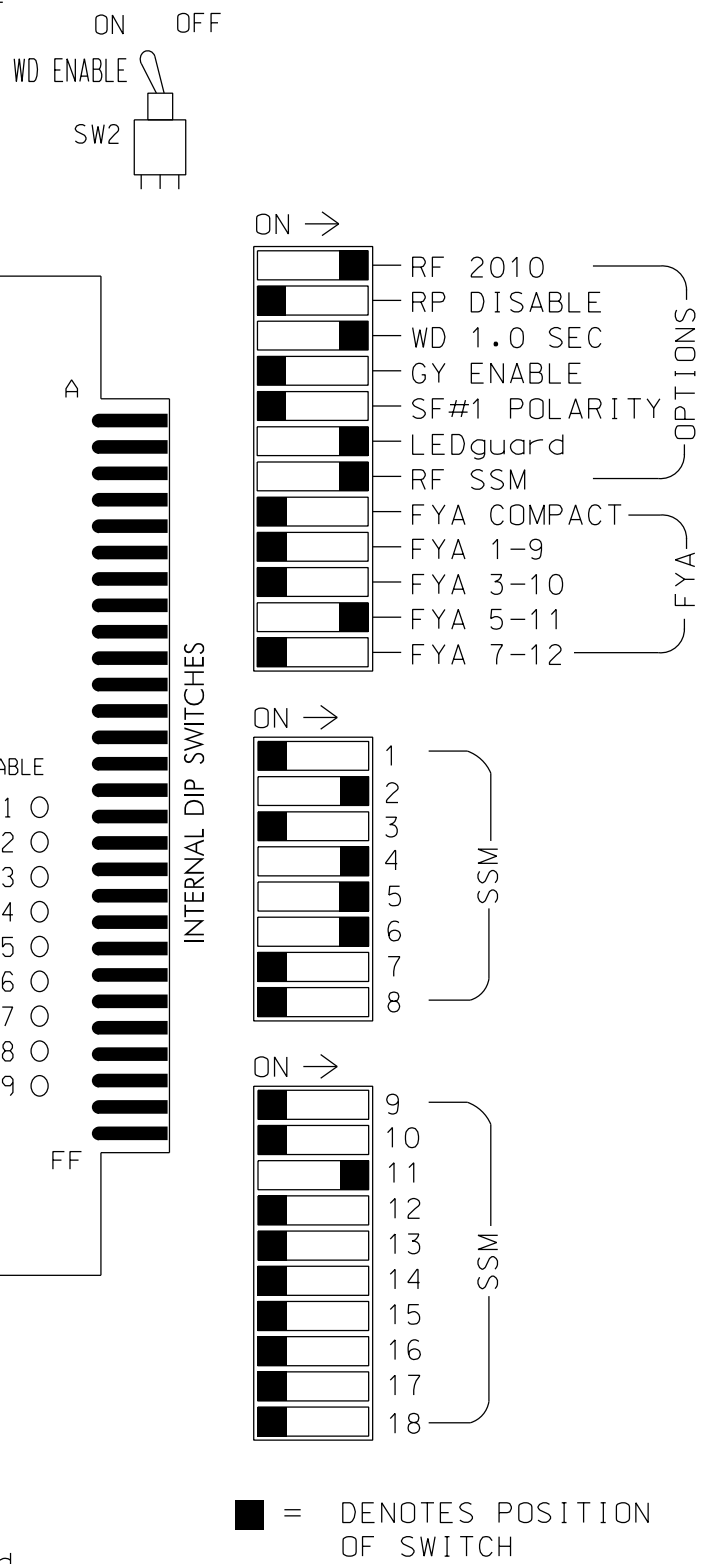

NOTES

1. To prevent "flash-conflict" problems, insert red flash program blocks for all unused vehicle load switches in the output file. The installer shall verify that signal heads flash in accordance with the Signal Plans.
2. Program controller to start up in phase 2 Green and 6 Green.
3. The cabinet and controller are part of the Burlington-Graham Signal System.

EQUIPMENT INFORMATION

CONTROLLER.....2070LX
 CABINET.....332 W/AUX
 SOFTWARE.....ECONOLITE ASC/3-2070
 CABINET MOUNT.....BASE
 OUTPUT FILE POSITIONS...18 WITH AUX. OUTPUT FILE
 LOAD SWITCHES USED.....S2,S5,S7,S8,AUX S4
 PHASES USED.....2,4,5,6
 OVERLAP "A".....NOT USED
 OVERLAP "B".....NOT USED
 OVERLAP "C".....*
 OVERLAP "D".....NOT USED

* See sheet 2 for overlap programming.

PROJECT REFERENCE NO.	SHEET NO.
U-6015	Sig. 147.1

SIGNAL HEAD HOOK-UP CHART

LOAD SWITCH NO.	S1	S2	S3	S4	S5	S6	S7	S8	S9	S10	S11	S12	AUX S1	AUX S2	AUX S3	AUX S4	AUX S5	AUX S6
CMU CHANNEL NO.	1	2	13	3	4	14	5	6	15	7	8	16	9	10	17	11	12	18
PHASE	1	2	2 PED	3	4	4 PED	5	6	6 PED	7	8	8 PED	OLA	OLB	SPARE	OLC	OLD	SPARE
SIGNAL HEAD NO.	NU	21,22	NU	NU	41,42	62	NU	42	51*	61,62	NU	NU	NU	NU	NU	51*	NU	NU
RED	128				101				*	134								
YELLOW		129			102					135								
GREEN		130			103					136								
RED ARROW																		A114
YELLOW ARROW					102			132										A115
FLASHING YELLOW ARROW																		A116
GREEN ARROW					103		133	133										

NU = Not Used

- * See pictorial of head wiring in detail this sheet.
- * Denotes install load resistor. See load resistor installation detail this sheet.

INPUT FILE POSITION LAYOUT

(front view)

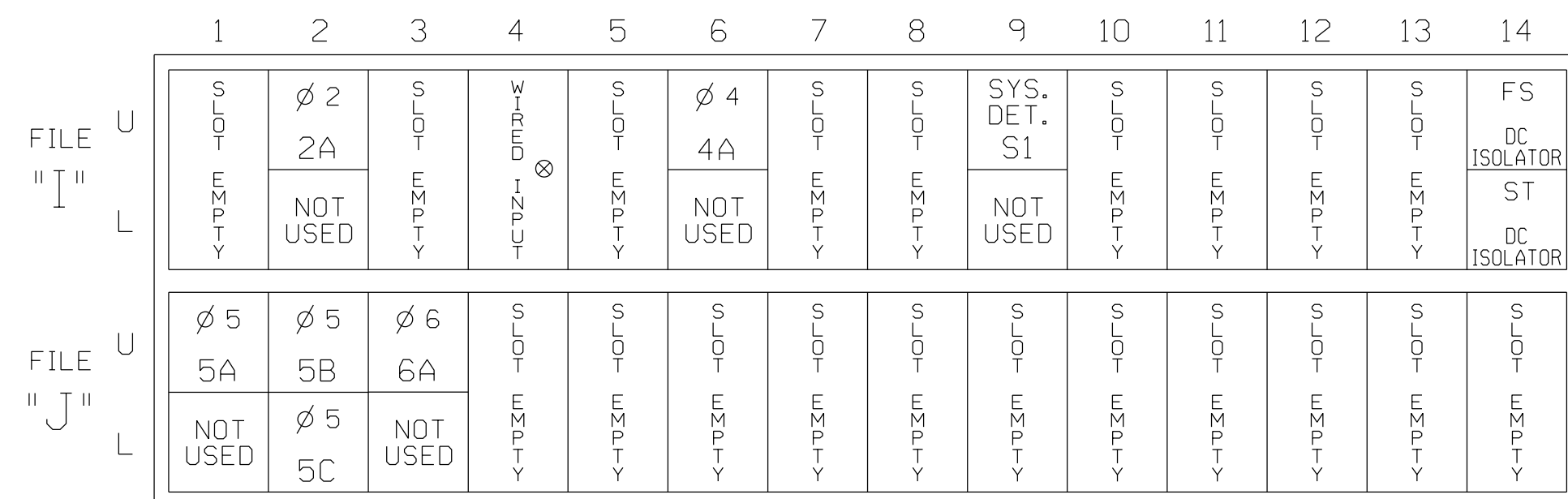

EX.: 1A, 2A, ETC. = LOOP NO.'S

FS = FLASH SENSE
 ST = STOP TIME

⊗ Wired Input - Do not populate slot with detector card

INPUT FILE CONNECTION & PROGRAMMING CHART

LOOP NO.	LOOP TERMINAL	INPUT FILE POS.	PIN NO.	DETECTOR NO.	NEMA PHASE	CALL	EXTEND TIME	DELAY TIME	ADDED INITIAL	DETECTOR TYPE
2A	TB2-5,6	I2U	39	2	2	YES			X	N
4A	TB4-9,10	I6U	41	4	4	YES		3		S
* S1	TB6-9,10	I9U	60	11	SYS	NO				N
5A ¹	TB3-1,2	J1U	55	5	5	YES		15		S
		I4U	47	22	2	YES		3		G
5B	TB3-5,6	J2U	40	6	6	YES		10		S
5C	TB3-7,8	J2L	44	16	6	YES		15		S
6A	TB3-9,10	J3U	64	36	6	YES			X	N

* System detector only. Remove any assigned vehicle phase.

¹Add jumper from J1-W to I4-W, on rear of input file.

INPUT FILE POSITION LEGEND: J2L

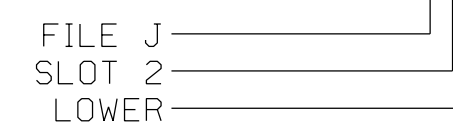

FYA SIGNAL WIRING DETAIL

(wire signal head as shown)

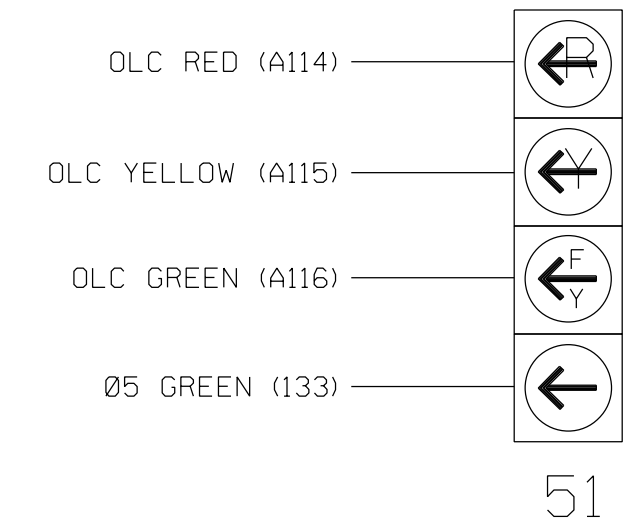

LOAD RESISTOR INSTALLATION DETAIL

(install resistor as shown)

VALUE (ohms)	WATTAGE
1.5K - 1.9K	25W (min)
2.0K - 3.0K	10W (min)

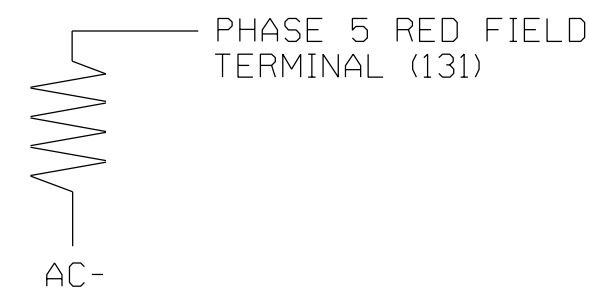

Electrical Detail - Sheet 1 of 2

ELECTRICAL AND PROGRAMMING DETAILS FOR: Prepared for the Offices of: 	NC 62 (Alamance Road) at SR 1213 (Grand Oaks Boulevard)	DOCUMENT NOT CONSIDERED FINAL UNLESS ALL SIGNATURES COMPLETED SEAL
	Division 7 Alamance County Burlington PLAN DATE: November 2017 REVIEWED BY: AM Encarnacion PREPARED BY: NA Ptak REVIEWED BY: PL Alexander	REVISIONS INIT. DATE _____ _____

ECONOLITE ASC/3-2070 OVERLAP PROGRAMMING DETAIL

(program controller as shown)

1. From Main Menu select 2. CONTROLLER
2. From CONTROLLER Submenu select 2. VEHICLE OVERLAPS

Toggle Twice

OVERLAP C

Select TMG VEH OVLP [C] and 'PPLT FYA'

```

TMG VEH OVLP...[C] TYPE: .....PPLT FYA
PROTECTED LEFT TURN.... PHASE 5
OPPOSING THROUGH..... PHASE 6

FLASHING ARROW OUTPUT.....CH11 ISOLATE
DELAY START OF: FYA..0.0 CLEARANCE..0.0
ACTION PLAN SF BIT DISABLE..... 0
    
```

END PROGRAMMING

THIS ELECTRICAL DETAIL IS FOR
 THE SIGNAL DESIGN: 07-1990
 DESIGNED: November 2017
 SEALED: 6/7/2018
 REVISED: N/A

Electrical Detail - Sheet 2 of 2

**DOCUMENT NOT CONSIDERED
 FINAL UNLESS ALL
 SIGNATURES COMPLETED**

<p style="font-size: small;">ELECTRICAL AND PROGRAMMING DETAILS FOR:</p> <p style="font-size: x-small; text-align: center;">Prepared for the Offices of:</p> <p style="font-size: x-small; text-align: center;">750 N. Greenfield Pkwy, Garner, NC 27529</p>	<p>NC 62 (Alamance Road) at SR 1213 (Grand Oaks Boulevard)</p> <p style="font-size: x-small;">Division 7 Alamance County Burlington</p> <p style="font-size: x-small;">PLAN DATE: November 2017 REVIEWED BY: AM Encarnacion</p> <p style="font-size: x-small;">PREPARED BY: NA Ptak REVIEWED BY: PL Alexander</p> <table border="1" style="width: 100%; border-collapse: collapse;"> <thead> <tr> <th style="font-size: x-small;">REVISIONS</th> <th style="font-size: x-small;">INIT.</th> <th style="font-size: x-small;">DATE</th> </tr> </thead> <tbody> <tr> <td> </td> <td> </td> <td> </td> </tr> </tbody> </table>	REVISIONS	INIT.	DATE				<p style="font-size: x-small;">SEAL</p> <p style="font-size: x-small;">6/9/2018</p> <p style="font-size: x-small;">Pamela Alexander</p> <p style="font-size: x-small;">DATE</p> <p style="font-size: x-small;">SIG. INVENTORY NO. 07-1990</p>
REVISIONS	INIT.	DATE						

ATKINS

1616 EAST MILLBROOK ROAD, SUITE 160
 RALEIGH, NORTH CAROLINA 27609
 (919) 876-6888 NCBEES #F-0326

09-JUN-2018 14:15
 D:\Consolidated\Projects\00056469 U-6015 B-G S19 SystemTask 05_11_Signal\Des\gn\wlr\ing\07-1990E.dgn
 ALEX3361 AT LUS330649

PHASING DIAGRAM

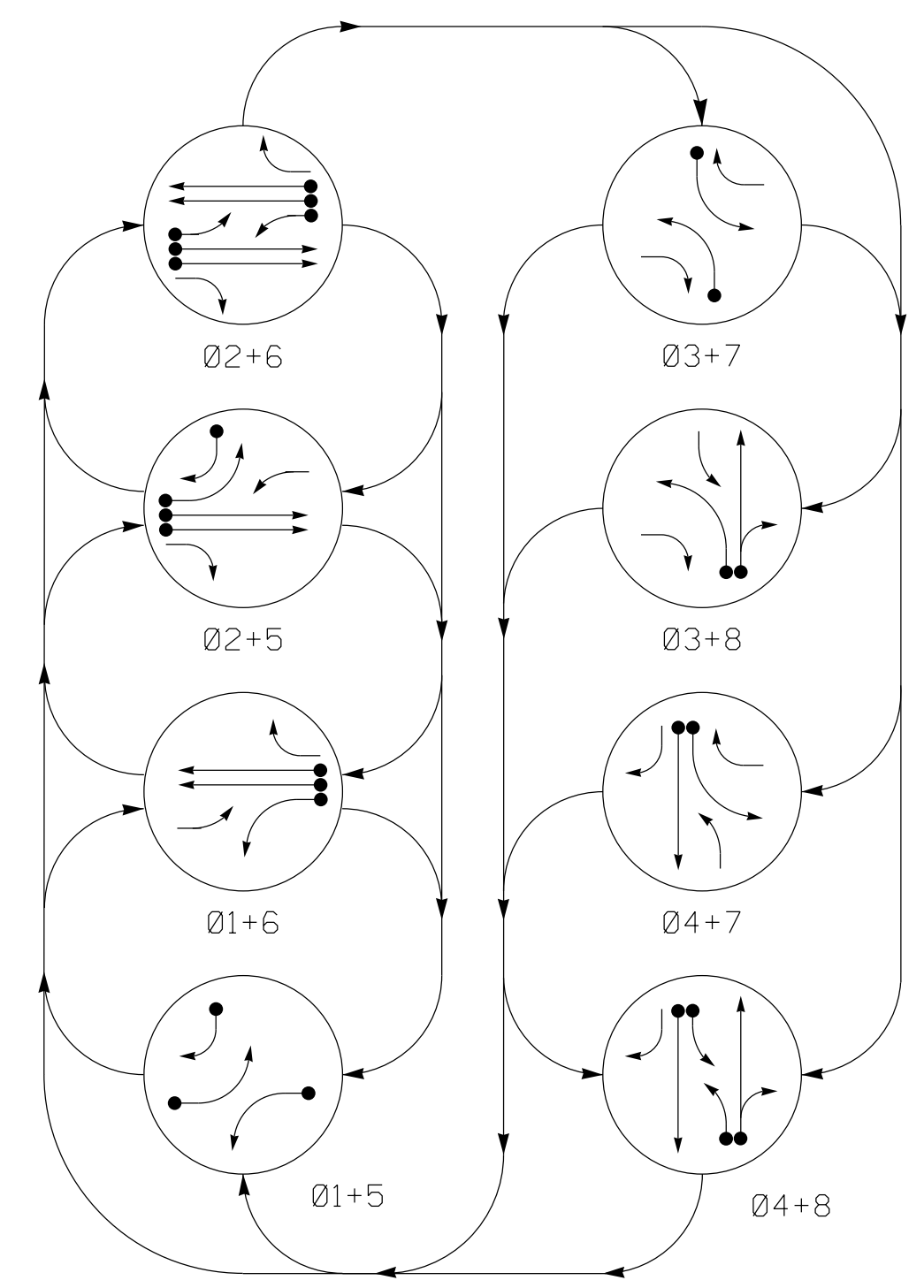
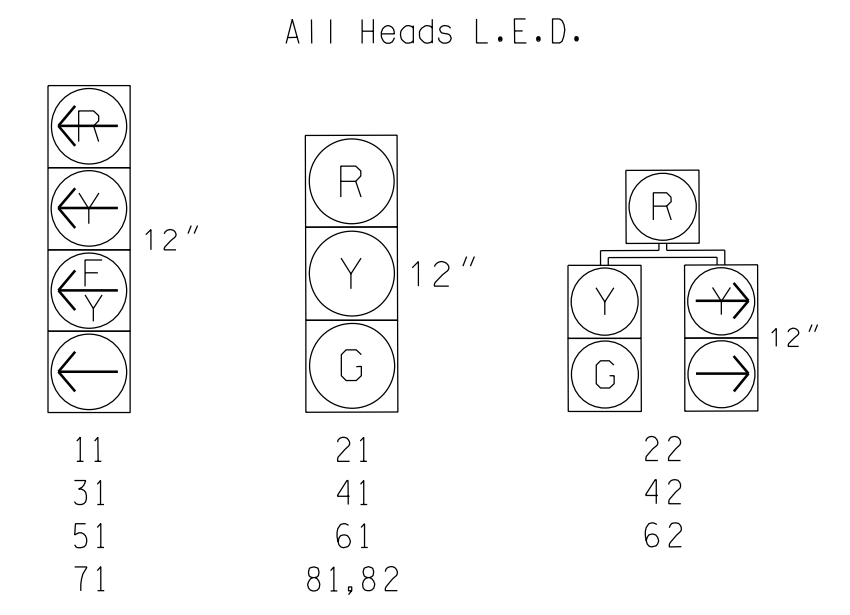

TABLE OF OPERATION

SIGNAL FACE	PHASE							
	01+5	02+6	03+7	04+8	05+9	06+0	07+1	08+2
11	-	-	F	F	R	R	R	Y
21	R	R	G	G	R	R	R	Y
22	R	R	G	G	R	R	R	Y
31	R	R	R	R	-	-	F	F
41	R	R	R	R	R	R	G	G
42	R	R	R	R	R	R	G	G
51	-	-	F	F	R	R	R	Y
61	R	G	R	G	R	R	R	Y
62	R	G	R	G	R	R	R	Y
71	R	R	R	R	-	-	F	F
81,82	R	R	R	R	R	G	R	G

SIGNAL FACE I.D.



PHASING DIAGRAM DETECTION LEGEND

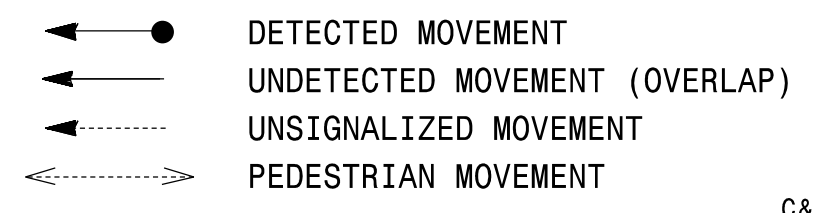

ASC/3 DETECTOR INSTALLATION CHART

LOOP	SIZE (FT)	DISTANCE FROM STOPBAR (FT)	TURNS	NEW LOOP	PROGRAMMING							
					PHASE	CALLING	EXTEND TIME	DELAY TIME	USE ADDED INITIAL	TYPE	SYSTEM LOOP	NEW CARD
1A	6X40	0	2-4-2	-	1	Yes	-	15	-	S	-	X
2A	6X6	300	EXIST	-	2	Yes	-	-	X	N	-	X
2B	6X6	300	EXIST	-	2	Yes	-	-	X	N	-	X
3A	6X40	0	2-4-2	-	3	Yes	-	15	-	S	-	X
4A	6X6	300	EXIST	-	4	No	2,4	-	-	S	-	X
4B	6X40	0	2-4-2	-	4	Yes	-	-	-	S	-	X
5A	6X40	0	2-4-2	-	5	Yes	-	15	-	S	-	X
5B	6X40	0	2-4-2	-	5	Yes	-	15	-	S	-	X
6A	6X6	310	EXIST	-	6	Yes	-	-	X	N	-	X
6B	6X6	310	EXIST	-	6	Yes	-	-	X	N	-	X
7A	6X40	+5	2-4-2	-	7	Yes	-	15	-	S	-	X
8A	6X6	300	EXIST	-	8	No	2,4	-	-	S	-	X
8B	6X40	300	2-4-2	-	8	Yes	-	10	-	S	-	X
S1	6X6	+150	EXIST	-	-	No	-	-	-	N	X	X
S2	6X6	+150	EXIST	-	-	No	-	-	-	N	X	X
S3	6X6	+180	EXIST	-	-	No	-	-	-	N	X	X
S4	6X6	+180	EXIST	-	-	No	-	-	-	N	X	X

8 Phase Fully Actuated (Burlington-Graham Signal System)

NOTES

1. Refer to "Roadway Standard Drawings NCDOT" dated January 2018 and "Standard Specifications for Roads and Structures" dated January 2018.
2. Do not program signal for late night flashing operation unless otherwise directed by the Engineer.
3. Phase 1 and/or phase 5 may be lagged.
4. Phase 3 and/or phase 7 may be lagged.
5. Reposition existing signal head numbered 82.
6. Set all detector units to presence mode.
7. In the event of loop replacement, refer to the current ITS and Signals Design Manual and submit a Plan of Record to the Signal Design Section.
8. Locate new cabinet so as to obstruct sight distances of vehicles turning right on red.
9. Pavement markings are existing.
10. Maximum times shown in timing chart are for free-run operation only. Coordinated signal system timing values supersede these values.

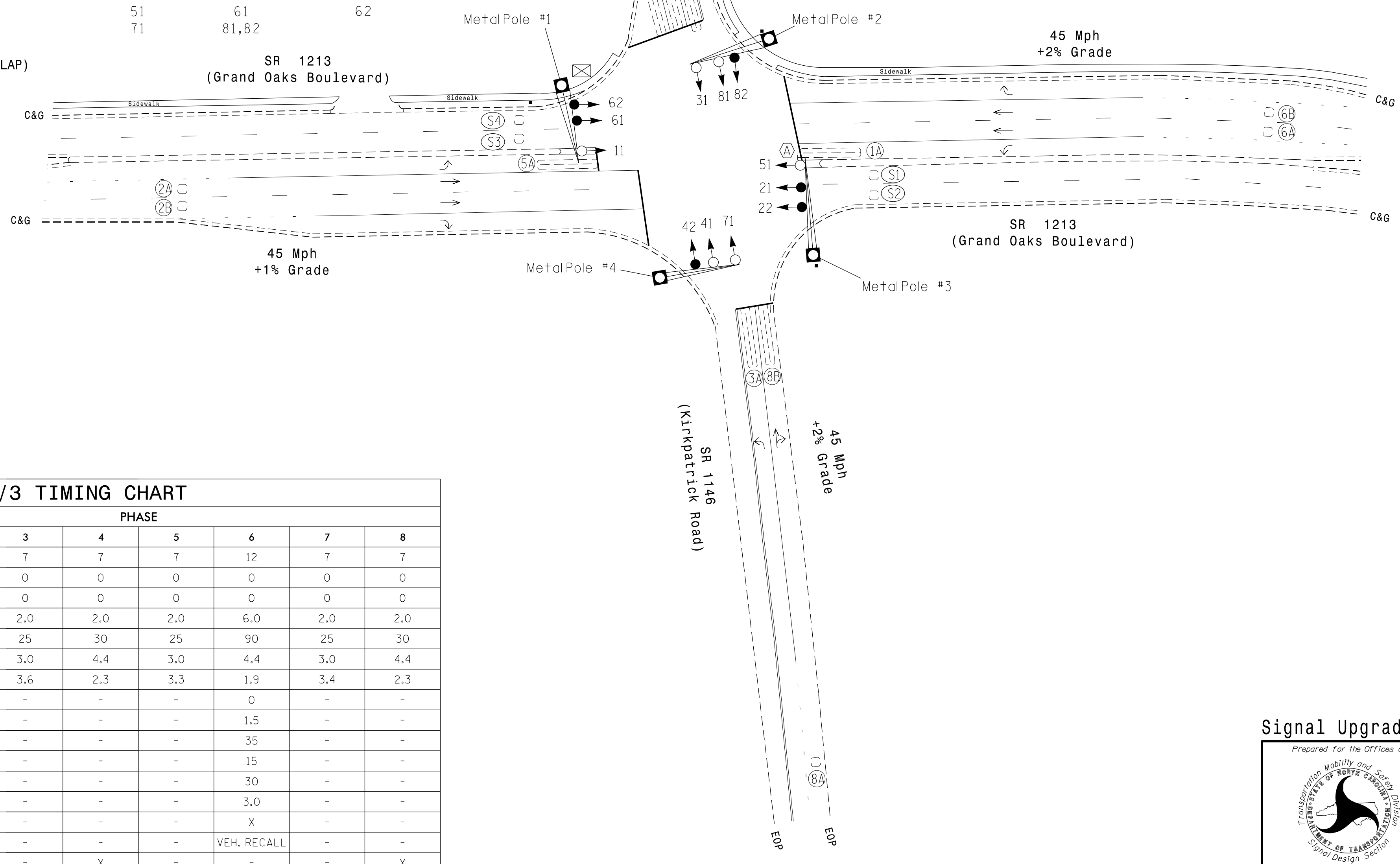

LEGEND

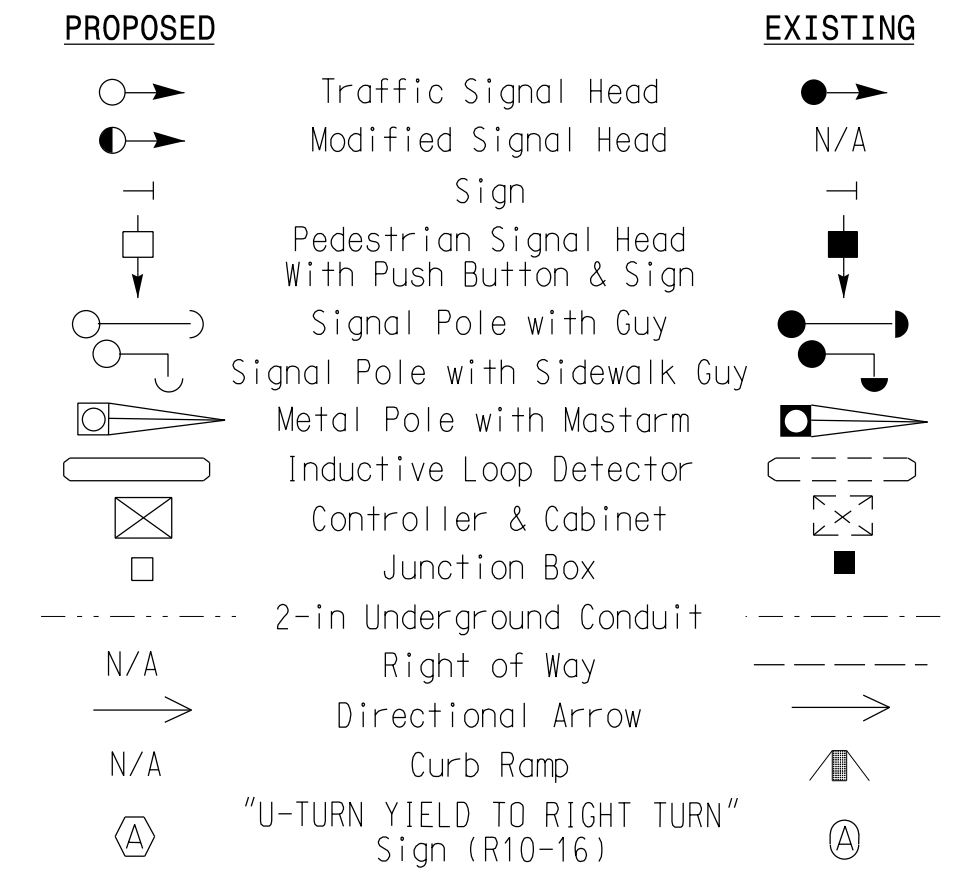

ASC/3 TIMING CHART

FEATURE	PHASE							
	1	2	3	4	5	6	7	8
Min Green *	7	12	7	7	7	12	7	7
Walk *	0	0	0	0	0	0	0	0
Ped Clear	0	0	0	0	0	0	0	0
Veh. Extension *	2.0	6.0	2.0	2.0	2.0	6.0	2.0	2.0
Max I *	25	90	25	30	25	90	25	30
Yellow	3.0	4.4	3.0	4.4	3.0	4.4	3.0	4.4
Red Clear	2.6	1.9	3.6	2.3	3.3	1.9	3.4	2.3
Actuations B4 Add *	-	0	-	-	-	0	-	-
Seconds /Actuation *	-	1.5	-	-	-	1.5	-	-
Max Initial *	-	34	-	-	-	35	-	-
Time Before Reduction *	-	15	-	-	-	15	-	-
Time To Reduce *	-	30	-	-	-	30	-	-
Minimum Gap	-	3.0	-	-	-	3.0	-	-
Locking Detector	-	X	-	-	-	X	-	-
Recall Position	-	VEH. RECALL	-	-	-	VEH. RECALL	-	-
Dual Entry	-	-	-	X	-	-	-	X
Simultaneous Gap	X	X	X	X	X	X	X	X

* These values may be field adjusted. Do not adjust Min Green and Extension times for phases 2 and 6 lower than what is shown. Min Green for all other phases should not be lower than 4 seconds.

Signal Upgrade

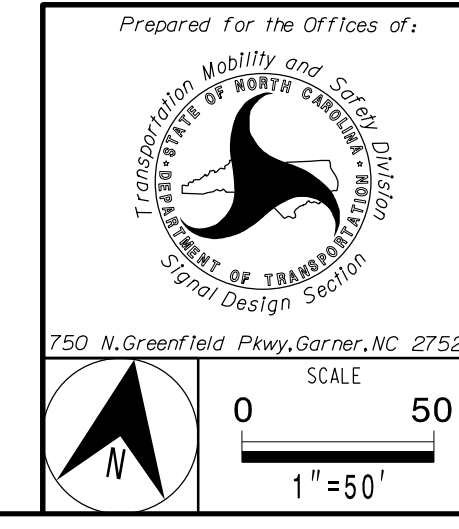

SR 1213 (Grand Oaks Boulevard) at SR 1146 (Kirkpatrick Road)

Division 7 Alamance County Burlington

PLAN DATE: November 2017 REVIEWED BY: AM Encarnacion

PREPARED BY: NA Ptak REVIEWED BY: PL Alexander

SCALE: 1"=50'

DATE: 6/7/2018

SIG. INVENTORY NO. 07-1991

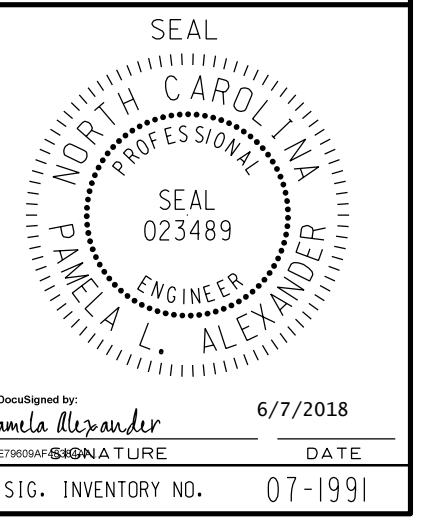

ATKINS 1616 EAST MILLBROOK ROAD, SUITE 160
RALEIGH, NORTH CAROLINA 27609
(919) 876-8888 NCBEES #F-0326

EDI MODEL 2018EClip-NC CONFLICT MONITOR PROGRAMMING DETAIL

(remove jumpers and set switches as shown)

REMOVE DIODE JUMPERS 1-5, 1-6, 1-9, 1-11, 2-5, 2-6, 2-9, 2-11, 3-7, 3-8, 3-10, 3-12, 4-7, 4-8, 4-10, 4-12, 5-9, 5-11, 6-9, 6-11, 7-10, 7-12, 8-10, 8-12, 9-11, and 10-12.

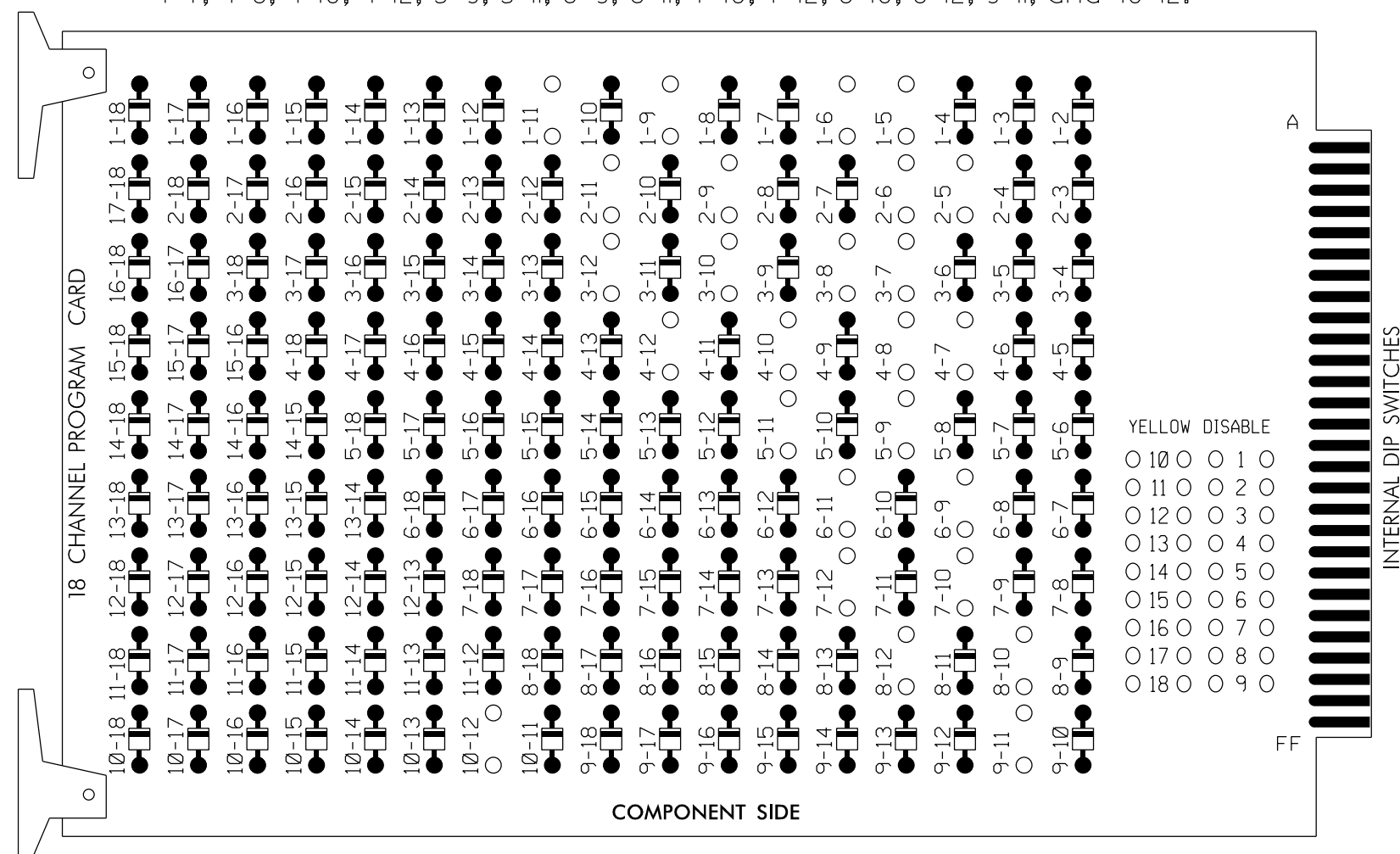

REMOVE JUMPERS AS SHOWN

NOTES:

- Card is provided with all diode jumpers in place. Removal of any jumper allows its channels to run concurrently.
- Ensure jumpers SEL2-SEL5 and SEL9 are present on the monitor board.
- Ensure that Red Enable is active at all times during normal operation.
- Integrate monitor with Ethernet network in cabinet.

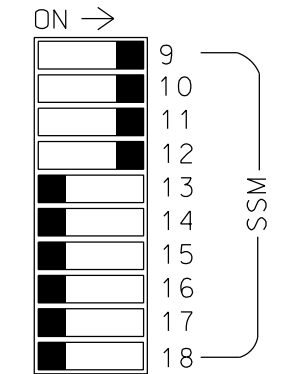
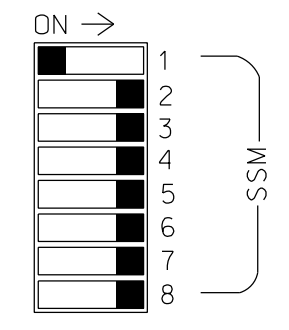
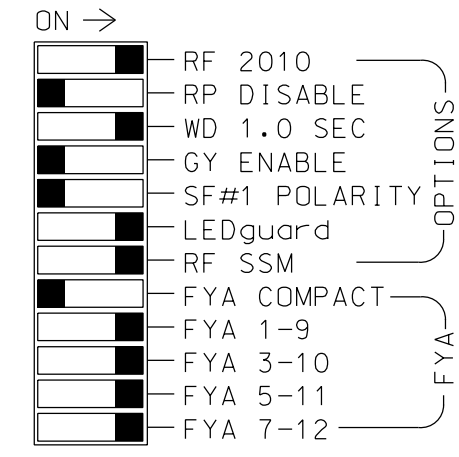
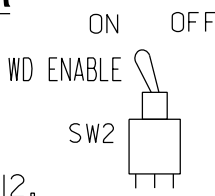

■ = DENOTES POSITION OF SWITCH

NOTES

- To prevent "flash-conflict" problems, insert red flash program blocks for all unused vehicle load switches in the output file. The installer shall verify that signal heads flash in accordance with the Signal Plans.
- Program phases 4 & 8 for Dual Entry.
- Program controller to start up in phase 2 Green and 6 Green.
- The cabinet and controller are part of the Burlington-Graham Signal System.

EQUIPMENT INFORMATION

CONTROLLER.....2070LX
 CABINET.....332 W/AUX
 SOFTWARE.....ECONOLITE ASC/3-2070
 CABINET MOUNT.....BASE
 OUTPUT FILE POSITIONS...18 WITH AUX. OUTPUT FILE
 LOAD SWITCHES USED.....S1,S2,S4,S5,S7,S8,S10,S11,
 AUX S1,AUX S2,AUX S4,AUX S5
 PHASES USED.....1,2,3,4,5,6,7,8
 OVERLAP "A".....*
 OVERLAP "B".....*
 OVERLAP "C".....*
 OVERLAP "D".....*

* See overlap programming detail on sheet 2

SIGNAL HEAD HOOK-UP CHART

LOAD SWITCH NO.	S1	S2	S3	S4	S5	S6	S7	S8	S9	S10	S11	S12	AUX S1	AUX S2	AUX S3	AUX S4	AUX S5	AUX S6				
CMU CHANNEL NO.	1	2	13	3	4	14	5	6	15	7	8	16	9	10	17	11	12	18				
PHASE	1	2	2 PED	3	4	4 PED	5	6	6 PED	7	8	8 PED	OLA	OLB	SPARE	OLC	OLD	SPARE				
SIGNAL HEAD NO.	11	21,22	NU	22	31	41,42	NU	42	51	61,62	NU	62	71	81,82	NU	11	31	NU	51	71	NU	
RED		128		*	101		*	134		*	107											
YELLOW	*	129			102			135			108											
GREEN		130			103			136			109											
RED ARROW													A121	A124		A114	A101					
YELLOW ARROW				117			132			123			A122	A125		A115	A102					
FLASHING YELLOW ARROW													A123	A126		A116	A103					
GREEN ARROW	127			118	118		133	133		124	124											

NU = Not Used

* Denotes install load resistor. See load resistor installation detail this sheet.

★ See pictorial of head wiring in detail this sheet.

INPUT FILE POSITION LAYOUT

(front view)

FILE "I"	1	2	3	4	5	6	7	8	9	10	11	12	13	14
U	∅ 1	∅ 2	∅ 3	∅ 4	∅ 5	∅ 6	∅ 7	∅ 8	∅ 9	∅ 10	∅ 11	∅ 12	∅ 13	∅ 14
L	1A	2A	3A	4A	5A	6A	7A	8A	9A	10A	11A	12A	13A	14A
U	NOT USED	∅ 2	∅ 6	∅ 8	∅ 5	∅ 6	∅ 7	∅ 8	∅ 9	∅ 10	∅ 11	∅ 12	∅ 13	∅ 14
L	2B	2B	6B	8B	5B	6B	7A	8A	9A	10A	11A	12A	13A	14A

EX. : 1A, 2A, ETC. = LOOP NO.*S

FS = FLASH SENSE
ST = STOP TIME

* Wired Input - Do not populate slot with detector card

INPUT FILE CONNECTION & PROGRAMMING CHART

LOOP NO.	LOOP TERMINAL	INPUT FILE POS.	PIN NO.	DETECTOR NO.	NEMA PHASE	CALL	EXTEND TIME	DELAY TIME	ADDED INITIAL	DETECTOR TYPE
1A ¹	TB2-1,2	J1U	56	1	1	YES		15		S
	-	J4U	48	26	6	YES		3		G
2A	TB2-5,6	J2U	39	2	2	YES			X	N
2B	TB2-7,8	J2L	43	12	2	YES			X	N
3A ²	TB4-5,6	J5U	58	3	3	YES		15		S
	-	J8U	50	28	8	YES		3		S
4A	TB4-9,10	J6U	41	4	4	NO	2,4			S
4B	TB4-11,12	J6L	45	14	4	YES				S
*S1	TB6-9,10	J9U	60	11	SYS	NO				N
*S2	TB6-11,12	J9L	62	13	SYS	NO				N
5A ³	TB3-1,2	J1U	55	5	5	YES		15		S
	-	J4U	47	22	2	YES		3		G
5B	TB3-5,6	J2U	40	6	5	YES		15		S
6A	TB3-9,10	J3U	64	36	6	YES			X	N
6B	TB3-11,12	J3L	77	46	6	YES			X	N
7A ⁴	TB5-5,6	J5U	57	7	7	YES		15		S
	-	J8U	49	24	4	YES		3		S
8A	TB5-9,10	J6U	42	8	8	NO	2,4			S
8B	TB5-11,12	J6L	46	18	8	YES		10		S
*S3	TB7-9,10	J9U	59	15	SYS	NO				N
*S4	TB7-11,12	J9L	61	17	SYS	NO				N

- Add jumper from I1-W to J4-W, on rear of input file.
 - Add jumper from I5-W to J8-W, on rear of input file.
 - Add jumper from J1-W to I4-W, on rear of input file.
 - Add jumper from J5-W to I8-W, on rear of input file.
- * System detector only. Remove any assigned vehicle phase.

INPUT FILE POSITION LEGEND: J2L

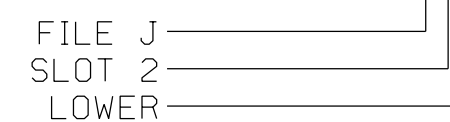

LOAD RESISTOR INSTALLATION DETAIL

(install resistors as shown)

VALUE (ohms)	WATTAGE
1.5K - 1.9K	25W (min)
2.0K - 3.0K	10W (min)

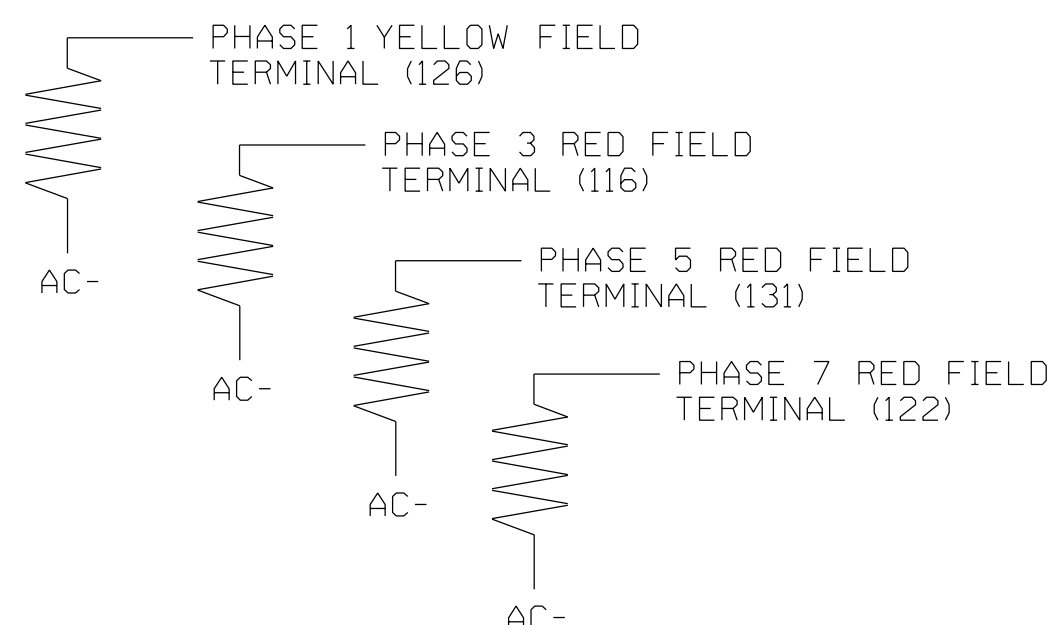

FYA PPLT SIGNAL WIRING DETAIL

(wire signal heads as shown)

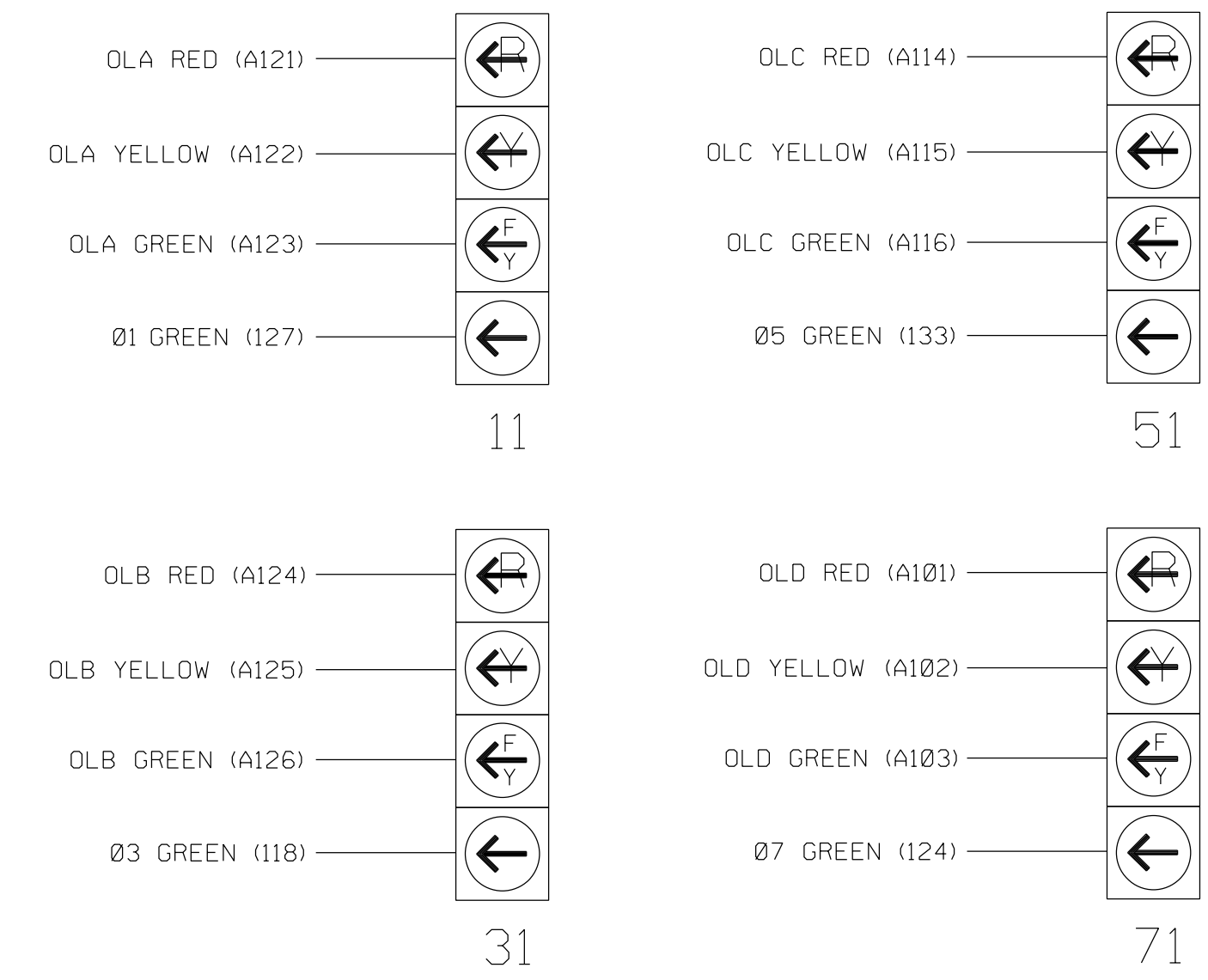

THIS ELECTRICAL DETAIL IS FOR THE SIGNAL DESIGN: 07-1991
 DESIGNED: November 2017
 SEALED: 6/7/2018
 REVISED: N/A

Electrical Detail - Sheet 1 of 2

Electrical and Programming Details For: **SR 1213 (Grand Oaks Boulevard) at SR 1146 (Kirkpatrick Road)**

Division 7 Alamance County Burlington

Plan Date: November 2017 Reviewed By: AM Encarnacion

Prepared By: NA Ptak Reviewed By: PL Alexander

Revisions: INIT. DATE

6/9/2018

Panela L. Alexander

Sig. Inventory No. 07-1991

ECONOLITE ASC/3-2070 OVERLAP PROGRAMMING DETAIL

(program controller as shown)

1. From Main Menu select 2. CONTROLLER
2. From CONTROLLER Submenu select 2. VEHICLE OVERLAPS

OVERLAP A

Select TMG VEH OVLP [A] and 'PPLT FYA'

TMG VEH OVLP...[A] TYPE:PPLT FYA

PROTECTED LEFT TURN.... PHASE 1

OPPOSING THROUGH..... PHASE 2

FLASHING ARROW OUTPUT.....CH9 ISOLATE

DELAY START OF: FYA..0.0 CLEARANCE..0.0

ACTION PLAN SF BIT DISABLE..... 0

Toggle Once

OVERLAP B

Select TMG VEH OVLP [B] and 'PPLT FYA'

TMG VEH OVLP...[B] TYPE:PPLT FYA

PROTECTED LEFT TURN.... PHASE 3

OPPOSING THROUGH..... PHASE 4

FLASHING ARROW OUTPUT.....CH10 ISOLATE

DELAY START OF: FYA..0.0 CLEARANCE..0.0

ACTION PLAN SF BIT DISABLE..... 0

Toggle Once

OVERLAP C

Select TMG VEH OVLP [C] and 'PPLT FYA'

TMG VEH OVLP...[C] TYPE:PPLT FYA

PROTECTED LEFT TURN.... PHASE 5

OPPOSING THROUGH..... PHASE 6

FLASHING ARROW OUTPUT.....CH11 ISOLATE

DELAY START OF: FYA..0.0 CLEARANCE..0.0

ACTION PLAN SF BIT DISABLE..... 0

Toggle Once

OVERLAP D

Select TMG VEH OVLP [D] and 'PPLT FYA'

TMG VEH OVLP...[D] TYPE:PPLT FYA

PROTECTED LEFT TURN.... PHASE 7

OPPOSING THROUGH..... PHASE 8

FLASHING ARROW OUTPUT.....CH12 ISOLATE

DELAY START OF: FYA..0.0 CLEARANCE..0.0

ACTION PLAN SF BIT DISABLE..... 0

END PROGRAMMING

FLASHER CIRCUIT MODIFICATION DETAIL

IN ORDER TO ENSURE THAT SIGNALS FLASH CONCURRENTLY ON THE SAME APPROACH, MAKE THE FOLLOWING FLASHER CIRCUIT CHANGES:

1. ON REAR OF PDA - REMOVE WIRE FROM TERM. T2-4 AND TERMINATE ON T2-2.
2. ON REAR OF PDA - REMOVE WIRE FROM TERM. T2-5 AND TERMINATE ON T2-3.
3. REMOVE FLASHER UNIT 2.

THE CHANGES LISTED ABOVE TIES ALL PHASES AND OVERLAPS TO FLASHER UNIT 1.

THIS ELECTRICAL DETAIL IS FOR THE SIGNAL DESIGN: 07-1991
 DESIGNED: November 2017
 SEALED: 6/7/2018
 REVISED: N/A

09-JUN-2018 14:15 D:\T\consort\at\work\offices\cur\100056469 U-6015 B-G S19 SysTask 05_11_Signal\Des\gn\mtr\ing\07-1991E.dgn ALEX3361 AT LUS210649

Electrical Detail - Sheet 2 of 2

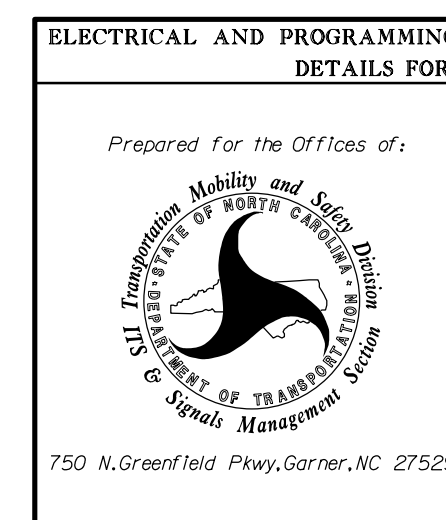

ELECTRICAL AND PROGRAMMING DETAILS FOR:		SR 1213 (Grand Oaks Boulevard) at SR 1146 (Kirkpatrick Road)	
Prepared for the Offices of:	Division 7	Alamance County	Burlington
PLAN DATE: November 2017	REVIEWED BY: AM Encarnacion	PREPARED BY: NA Ptak	REVIEWED BY: PL Alexander
REVISIONS	INIT.	DATE	

DOCUMENT NOT CONSIDERED FINAL UNLESS ALL SIGNATURES COMPLETED

6/9/2018

Pamela Alexander

DATE

SIG. INVENTORY NO. 07-1991

ATKINS 1616 EAST MILLBROOK ROAD, SUITE 160
 RALEIGH, NORTH CAROLINA 27609
 (919) 876-6888 NCBEES #F-0326

PHASING DIAGRAM

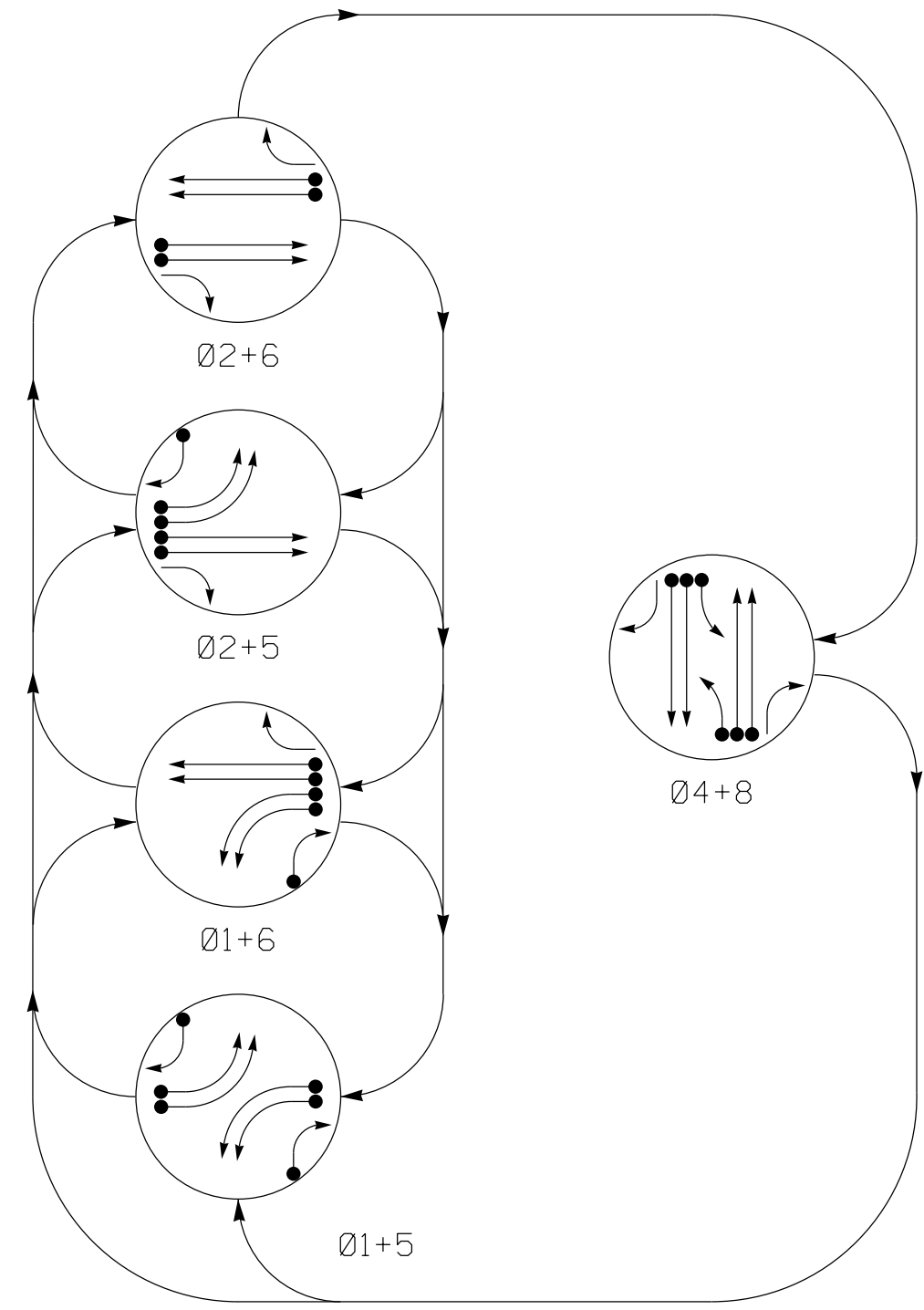
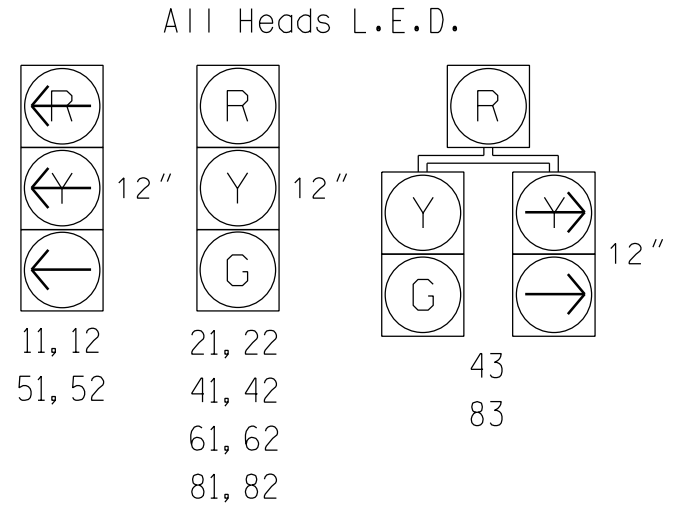

TABLE OF OPERATION

SIGNAL FACE	PHASE				
	Ø 1 + 5	Ø 1 + 6	Ø 2 + 5	Ø 2 + 6	Ø 4 + 8
11, 12	←	←	←	←	←
21, 22	R	R	G	G	R
41, 42	R	R	R	R	R
43	R	R	R	R	R
51, 52	←	←	←	←	←
61, 62	R	G	R	G	R
81, 82	R	R	R	R	R
83	R	R	R	R	R

SIGNAL FACE I.D.



ASC/3 DETECTOR INSTALLATION CHART

LOOP	SIZE (FT)	DISTANCE FROM STOPBAR (FT)	TURNS	NEW LOOP	PROGRAMMING							
					PHASE	CALLING	EXTEND TIME	DELAY TIME	USE ADDED INITIAL	TYPE	LOOP	NEW CARD
1A	6X60	0	2-4-2	-	1	Yes	-	-	-	S	-	X
1B	6X60	0	2-4-2	-	1	Yes	-	-	-	S	-	X
1C	6X60	0	2-4-2	-	1	Yes	-	15	-	S	-	X
2A, 2B	6X6	330	EXIST	-	2	Yes	0.5	-	X	N	-	X
4A, 4B	6X6	300	EXIST	-	4	No	3.7	-	-	S	-	X
4C	6X60	0	2-4-2	-	4	Yes	-	3	-	S	-	X
4D	6X60	0	2-4-2	-	4	Yes	-	-	-	S	-	X
4E	6X60	0	2-4-2	-	4	Yes	-	-	-	S	-	X
5A	6X60	0	2-4-2	-	5	Yes	-	-	-	S	-	X
5B	6X60	0	2-4-2	-	5	Yes	-	-	-	S	-	X
5C	6X60	0	2-4-2	-	5	Yes	-	15	-	S	-	X
6A, 6B	6X6	330	EXIST	-	6	Yes	0.5	-	X	N	-	X
8A, 8B	6X6	300	EXIST	-	8	No	3.7	-	-	S	-	X
8C	6X60	0	2-4-2	-	8	Yes	-	3	-	S	-	X
8D	6X60	0	2-4-2	-	8	Yes	-	-	-	S	-	X
8E	6X60	0	2-4-2	-	8	Yes	-	-	-	S	-	X
S1	6X6	+150	EXIST	-	-	No	-	-	-	N	X	X
S2	6X6	+150	EXIST	-	-	No	-	-	-	N	X	X
S3	6X6	+150	EXIST	-	-	No	-	-	-	N	X	X
S4	6X6	+150	EXIST	-	-	No	-	-	-	N	X	X

5 Phase Fully Actuated (Burlington-Graham Signal System)

NOTES

1. Refer to "Roadway Standard Drawings NCDOT" dated January 2018 and "Standard Specifications for Roads and Structures" dated January 2018.
2. Do not program signal for late night flashing operation unless otherwise directed by the Engineer.
3. Phase 1 and/or phase 5 may be lagged.
4. Set all detector units to presence mode.
5. In the event of loop replacement, refer to the current ITS and Signals Design Manual and submit a Plan of Record to the Signal Design Section.
6. Locate new cabinet so as not to obstruct sight distance of vehicles turning right on red.
7. The cabinet should be designed to include an Auxiliary Output File for future use.
8. Pavement markings are existing.
9. Maximum times shown in timing chart are for free-run operation only. Coordinated signal system timing values supersede these values.

PHASING DIAGRAM DETECTION LEGEND

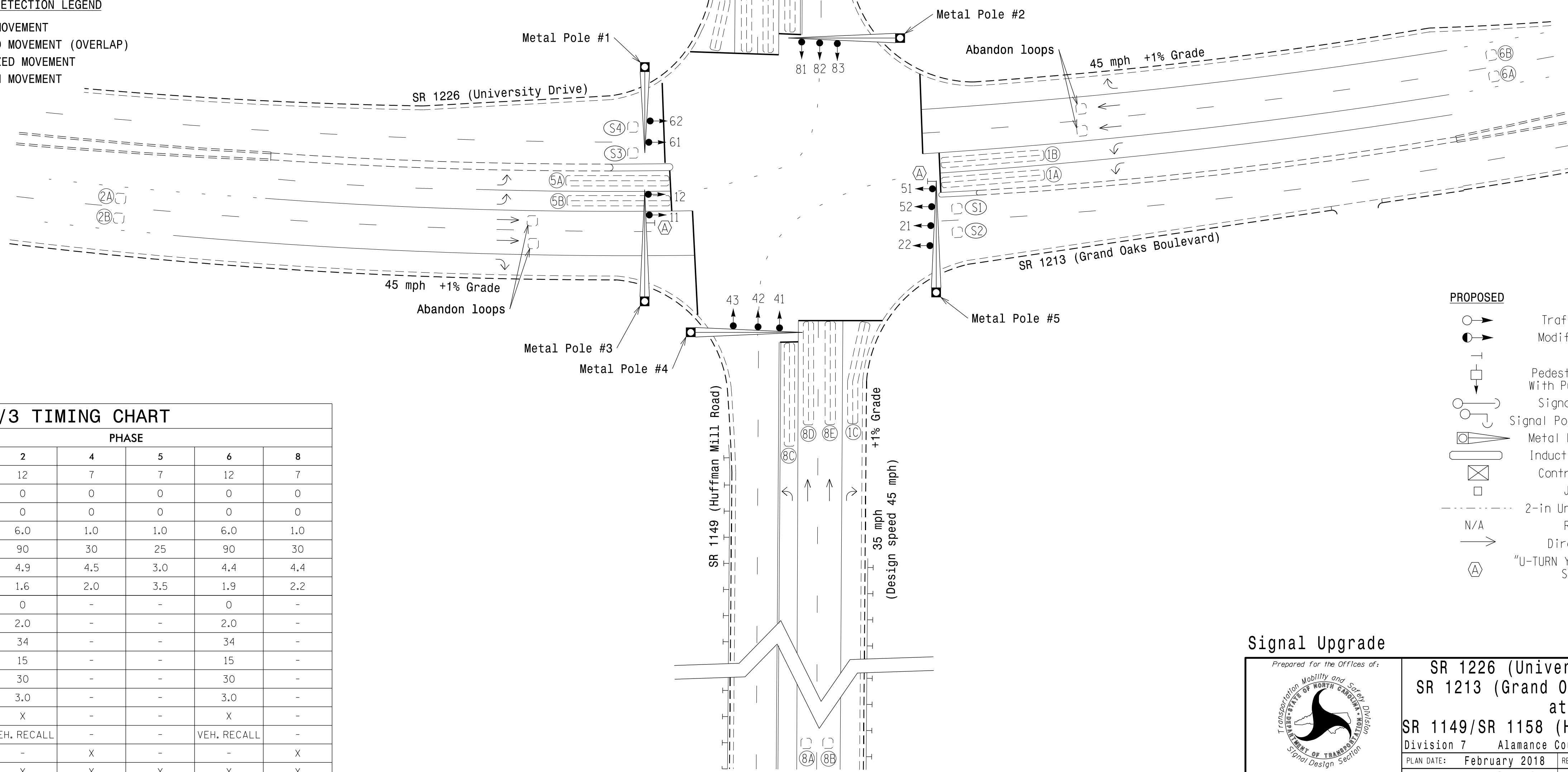
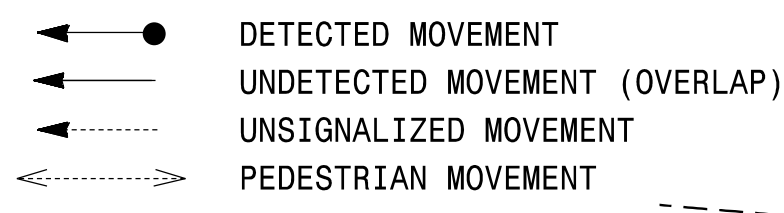

ASC/3 TIMING CHART

FEATURE	PHASE							
	1	2	4	5	6	8		
Min Green *	7	12	7	7	12	7		
Walk *	0	0	0	0	0	0		
Ped Clear	0	0	0	0	0	0		
Veh. Extension *	1.0	6.0	1.0	1.0	6.0	1.0		
Max 1 *	25	90	30	25	90	30		
Yellow	3.0	4.9	4.5	3.0	4.4	4.4		
Red Clear	3.7	1.6	2.0	3.5	1.9	2.2		
Actuations B4 Add *	-	0	-	-	0	-		
Seconds / Actuation *	-	2.0	-	-	2.0	-		
Max Initial *	-	34	-	-	34	-		
Time Before Reduction *	-	15	-	-	15	-		
Time To Reduce *	-	30	-	-	30	-		
Minimum Gap	-	3.0	-	-	3.0	-		
Locking Detector	-	X	-	-	X	-		
Recall Position	-	VEH. RECALL	-	-	VEH. RECALL	-		
Dual Entry	-	-	X	-	-	X		
Simultaneous Gap	X	X	X	X	X	X		

* These values may be field adjusted. Do not adjust Min Green and Extension times for phases 2 and 6 lower than what is shown. Min Green for all other phases should not be lower than 4 seconds.

LEGEND

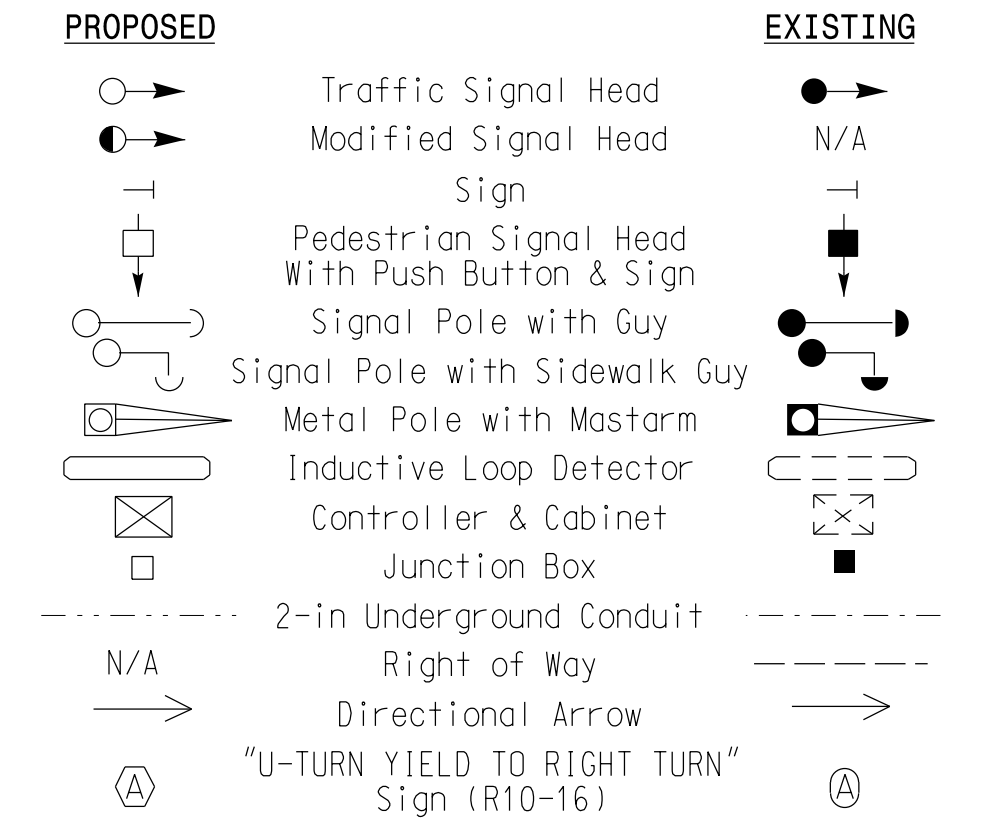

Signal Upgrade

Prepared For the Offices of:

SR 1226 (University Drive) / SR 1213 (Grand Oaks Boulevard) at SR 1149/SR 1158 (Huffman Mill Rd)

Division 7 Alamance County Burlington

PLANNING: February 2018 REVIEWED BY: MB Toth

PREPARED BY: PL Alexander REVIEWED BY:

SCALE: 1" = 40'

REVISIONS: INIT. DATE

DOCUMENT NOT CONSIDERED FINAL UNLESS ALL SIGNATURES COMPLETED

SEAL: PAMELA L. ALEXANDER, PROFESSIONAL ENGINEER, No. 023489

DATE: 6/7/2018

SIG. INVENTORY NO. 07-1992

07-JUN-2018 11:15 ***DOT/ITS-COM/PROJECT/ITS/RA/Transportation/Office/Curr/00056469 U-6015 B-0 Sigs Task 05-11-15 Signal is 0605 09M07-1992.dgn ALEX3361 AT LUS52069

EDI MODEL 2018ECLip-NC CONFLICT MONITOR PROGRAMMING DETAIL

(remove jumpers and set switches as shown)

REMOVE DIODE JUMPERS I-5, I-6, 2-5, 2-6 and 4-8.

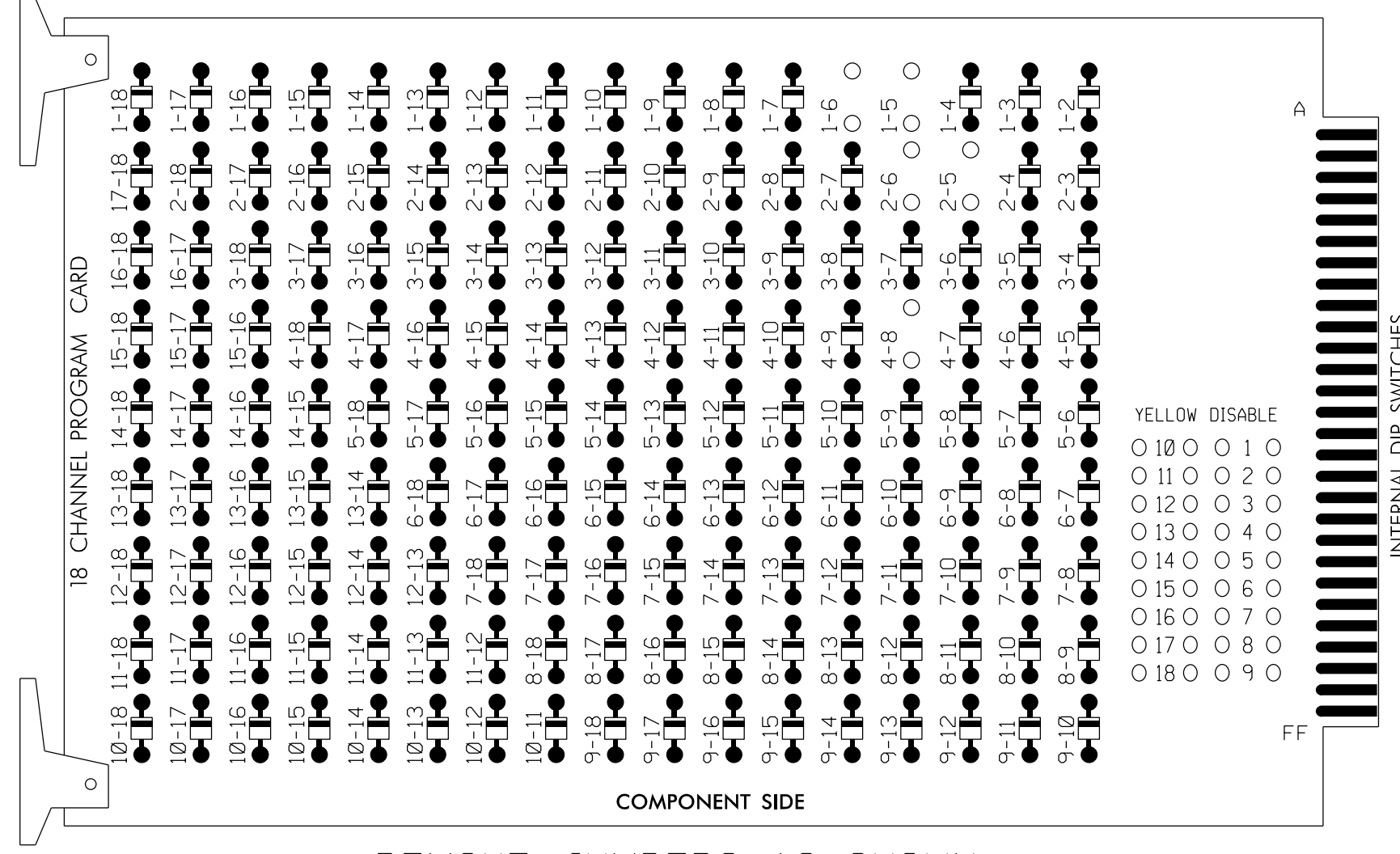

REMOVE JUMPERS AS SHOWN

NOTES:

1. Card is provided with all diode jumpers in place. Removal of any jumper allows its channels to run concurrently.
2. Ensure jumpers SEL2-SEL5 and SEL9 are present on the monitor board.
3. Ensure that Red Enable is active at all times during normal operation.
4. Integrate monitor with Ethernet network in cabinet.

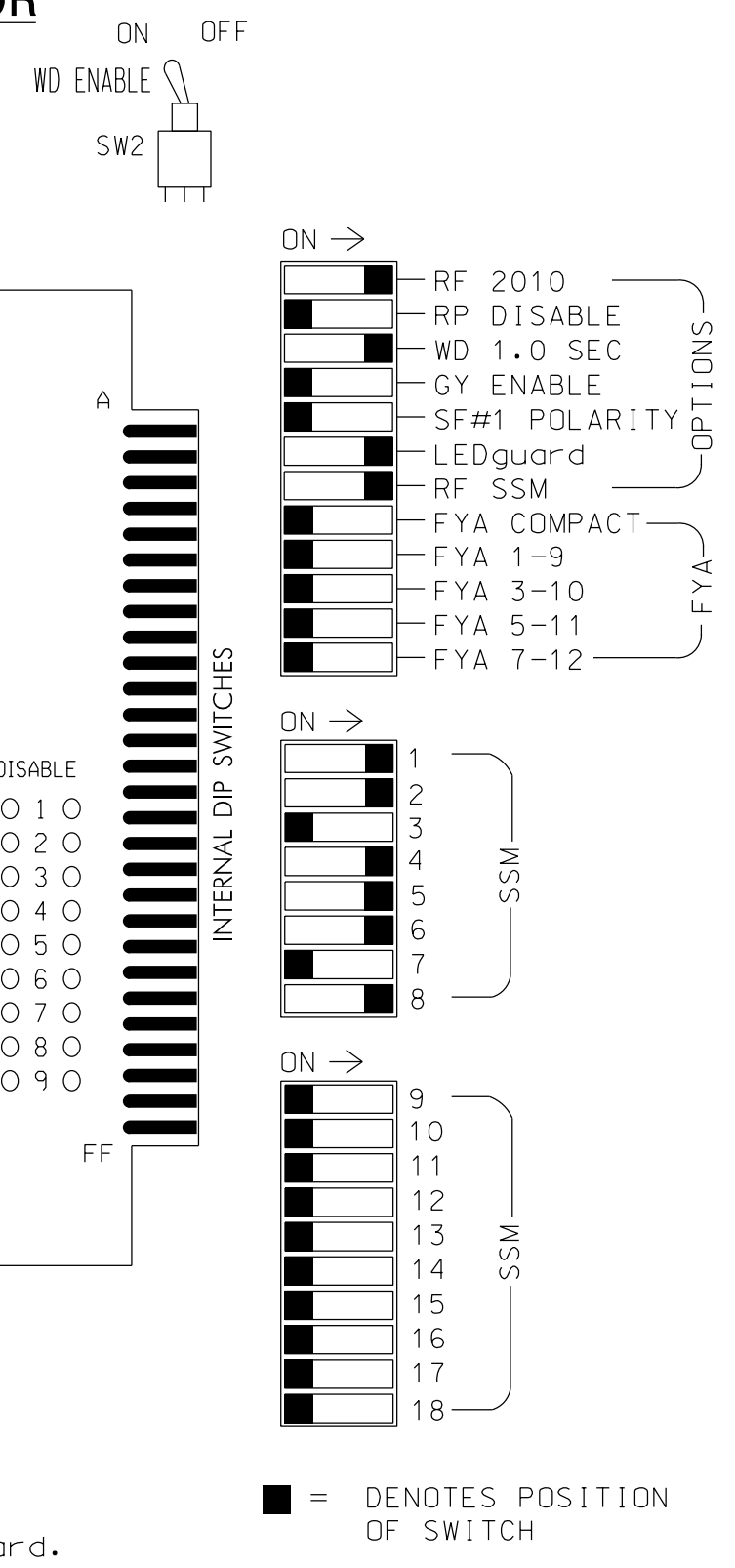

NOTES

1. To prevent "flash-conflict" problems, insert red flash program blocks for all unused vehicle load switches in the output file. The installer shall verify that signal heads flash in accordance with the Signal Plans.
2. Program phases 4 and 8 for Dual Entry.
3. Program controller to start up in phase 2 Green and 6 Green.
4. The cabinet and controller are part of the Burlington-Graham Signal System.

EQUIPMENT INFORMATION

CONTROLLER.....2070LX
 CABINET.....332 W/AUX
 SOFTWARE.....ECONDLITE ASC/3-2070
 CABINET MOUNT.....BASE
 OUTPUT FILE POSITIONS...18 WITH AUX. OUTPUT FILE
 LOAD SWITCHES USED.....S1,S2,S5,S7,S8,S11
 PHASES USED.....1,2,4,5,6,8
 OVERLAP "A".....NOT USED
 OVERLAP "B".....NOT USED
 OVERLAP "C".....NOT USED
 OVERLAP "D".....NOT USED

SIGNAL HEAD HOOK-UP CHART

LOAD SWITCH NO.	S1	S2	S3	S4	S5	S6	S7	S8	S9	S10	S11	S12	AUX S1	AUX S2	AUX S3	AUX S4	AUX S5	AUX S6
CMU CHANNEL NO.	1	2	13	3	4	14	5	6	15	7	8	16	9	10	17	11	12	18
PHASE	1	2	2 PED	3	4	4 PED	5	6	6 PED	7	8	8 PED	OLA	OLB	SPARE	OLC	OLD	SPARE
SIGNAL HEAD NO.	11,12	83	21,22	NU	NU	41,42 43	NU	43	51,52	61,62	NU	NU	81,82 83	NU	NU	NU	NU	NU
RED		128			101				134				107					
YELLOW			129		102				135				108					
GREEN			130		103				136				109					
RED ARROW	125								131									
YELLOW ARROW	126	126						132	132									
GREEN ARROW	127	127						133	133									

NU = Not Used

INPUT FILE POSITION LAYOUT

(front view)

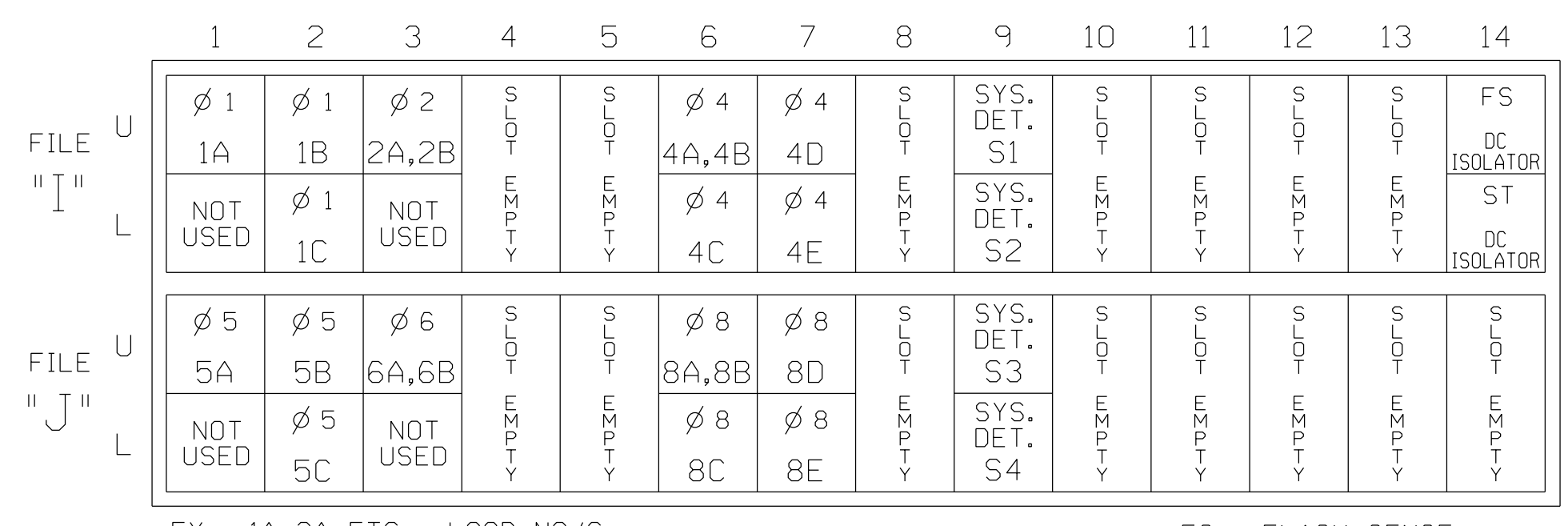

EX.: 1A, 2A, ETC. = LOOP NO.'S

FS = FLASH SENSE
 ST = STOP TIME

INPUT FILE CONNECTION & PROGRAMMING CHART

LOOP NO.	LOOP TERMINAL	INPUT FILE POS.	PIN NO.	DETECTOR NO.	NEMA PHASE	CALL	EXTEND TIME	DELAY TIME	ADDED INITIAL	DETECTOR TYPE
1A	TB2-1,2	I1U	56	1	1	YES				S
1B	TB2-5,6	I2U	39	2	1	YES				S
1C	TB2-7,8	I2L	43	12	1	YES		15		S
2A, 2B	TB2-9,10	I3U	63	32	2	YES			X	N
4A, 4B	TB4-9,10	I6U	41	4	4	NO	3.7			S
4C	TB4-11,12	I6L	45	14	4	YES		3		S
4D	TB6-1,2	I7U	65	34	4	YES				S
4E	TB6-3,4	I7L	78	44	4	YES				S
* S1	TB6-9,10	I9U	60	11	SYS	NO				N
* S2	TB6-11,12	I9L	62	13	SYS	NO				N
5A	TB3-1,2	J1U	55	5	5	YES				S
5B	TB3-5,6	J2U	40	6	5	YES				S
5C	TB3-7,8	J2L	44	16	5	YES		15		S
6A, 6B	TB3-9,10	J3U	64	36	6	YES			X	N
8A, 8B	TB5-9,10	J6U	42	8	8	NO	3.7			S
8C	TB5-11,12	J6L	46	18	8	YES		3		S
8D	TB7-1,2	J7U	66	38	8	YES				S
8E	TB7-3,4	J7L	79	48	8	YES				S
* S3	TB7-9,10	J9U	59	15	SYS	NO				N
* S4	TB7-11,12	J9L	61	17	SYS	NO				N

* System detector only. Remove any assigned vehicle phase.

INPUT FILE POSITION LEGEND: J2L

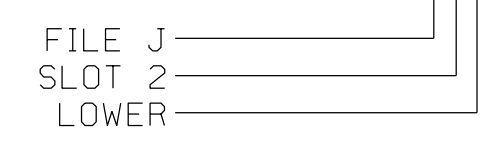

THIS ELECTRICAL DETAIL IS FOR THE SIGNAL DESIGN: 07-1992
 DESIGNED: February 2018
 SEALED: 6/7/2018
 REVISED: N/A

Electrical Detail

Electrical and Programming Details For:
 Prepared for the Offices of:

SR 1226 (University Drive)/ SR 1213 (Grand Oaks Boulevard) at SR 1149/SR 1158 (Huffman Mill Road)	
Division 7	Alamance County Burlington
PLAN DATE: February 2018	REVIEWED BY: MB Toth
PREPARED BY: PL Alexander	REVIEWED BY:
REVISIONS	INIT. DATE

DOCUMENT NOT CONSIDERED FINAL UNLESS ALL SIGNATURES COMPLETED

Signature: Pamela L. Alexander
 Date: 6/9/2018
 SIG. INVENTORY NO. 07-1992

PHASING DIAGRAM

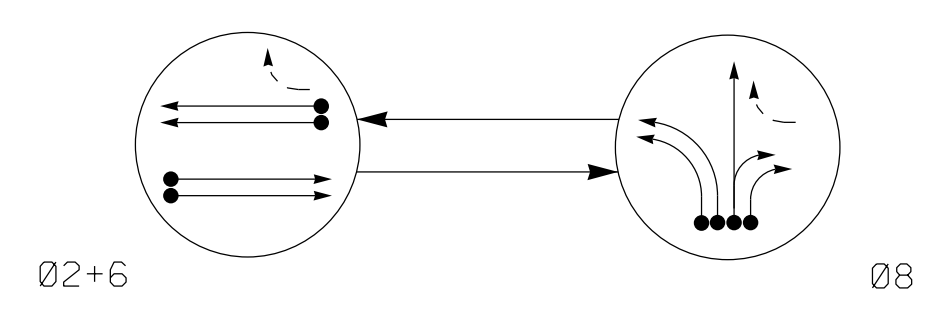

PHASING DIAGRAM DETECTION LEGEND
 ● DETECTED MOVEMENT
 ○ UNDETECTED MOVEMENT (OVERLAP)
 ○ UNSIGNALIZED MOVEMENT
 ○ PEDESTRIAN MOVEMENT

TABLE OF OPERATION

SIGNAL FACE	PHASE		
	ON	OFF	FLASH
21,22	G	R	Y
61,62	G	R	Y
81,82,83	R	G	R

SIGNAL FACE I.D.

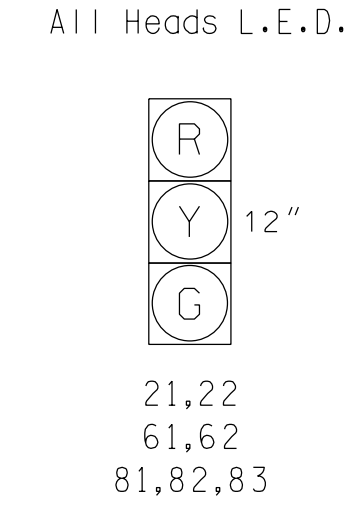

ASC/3 DETECTOR INSTALLATION CHART

LOOP	SIZE (FT)	DISTANCE FROM STOPBAR (FT)	TURNS	NEW LOOP	PHASE	PROGRAMMING						
						CALLING	EXTEND TIME	DELAY TIME	USE ADDED INITIAL	SYSTEM LOOP	NEW CARD	
2A,2B	6X6	360	EXIST	-	2	Yes	1.0	-	X	N	-	X
6A,6B	6X6	360	EXIST	-	6	Yes	1.0	-	X	N	-	X
8A	6X40	0	2-4-2	-	8	Yes	-	-	-	S	-	X
8B	6X60	0	2-4-2	-	8	Yes	-	-	-	S	-	X
8C	6X60	0	2-4-2	-	8	Yes	-	10	-	S	-	X
8D	6X60	0	2-4-2	-	8	Yes	-	15	-	S	-	X
S1	6X6	+150	EXIST	-	-	NO	-	-	-	N	X	X
S2	6X6	+150	EXIST	-	-	NO	-	-	-	N	X	X
S3	6X6	+425	EXIST	-	-	NO	-	-	-	N	X	X
S4	6X6	+425	EXIST	-	-	NO	-	-	-	N	X	X

2 Phase Fully Actuated (Burlington-Graham Signal System)

NOTES

1. Refer to "Roadway Standard Drawings NCDOT" dated January 2018 and "Standard Specifications for Roads and Structures" dated January 2018.
2. Do not program signal for late night flashing operation unless otherwise directed by Engineer.
3. Set all detector units to presence mode.
4. In the event of loop replacement, refer to the current ITS and Signals Design Manual and submit a Plan of Record to the Signal Design Section.
5. Locate new cabinet so as not to obstruct sight distance of vehicles turning right on red.
6. The cabinet should be designed to include an Auxiliary Output File for future use.
7. Pavement markings are existing.
8. Maximum times shown in timing chart are for free-run operation only. Coordinated signal system timing values supersede these values.

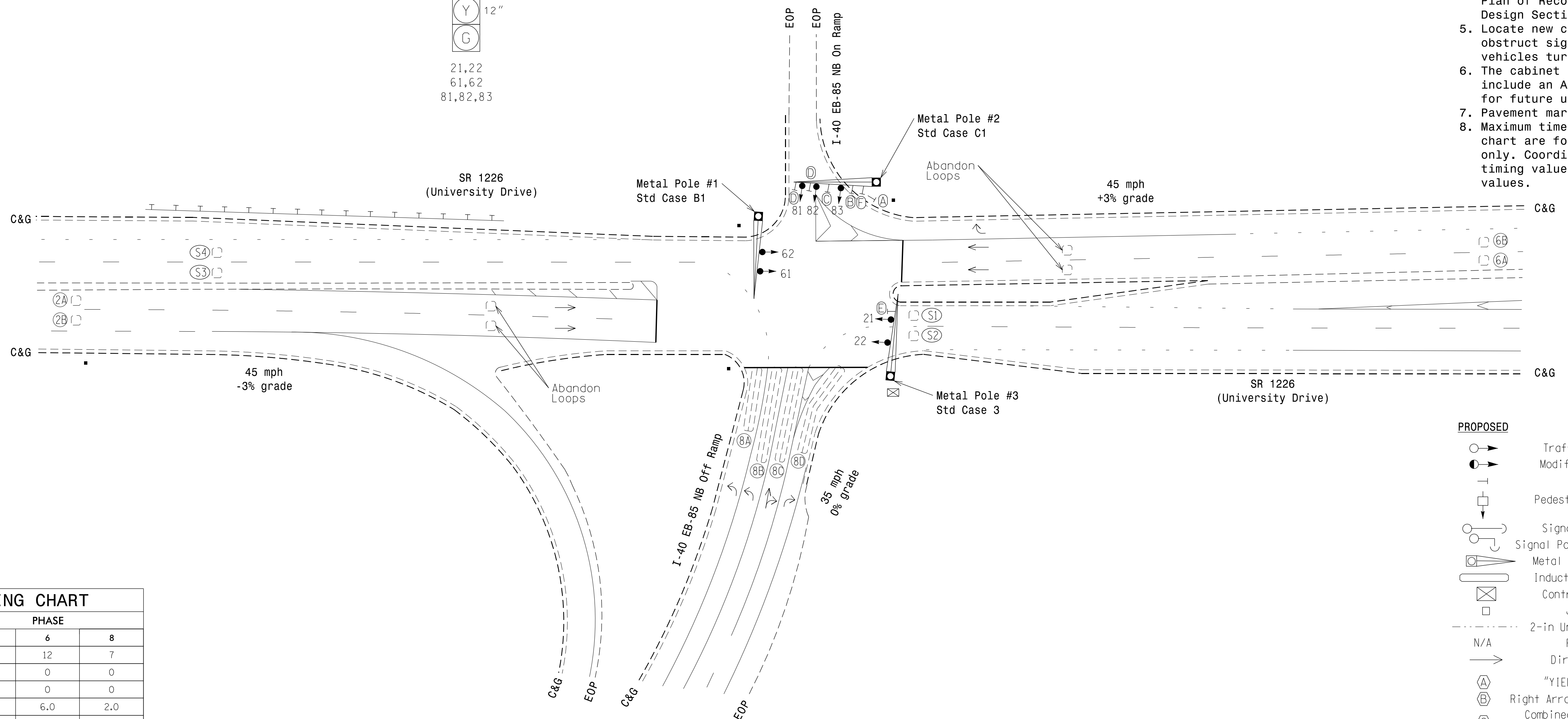

ASC/3 TIMING CHART

FEATURE	PHASE		
	2	6	8
Min Green *	12	12	7
Walk *	0	0	0
Ped Clear	0	0	0
Veh. Extension *	6.0	6.0	2.0
Max 1 *	90	90	30
Yellow	4.8	4.3	3.8
Red Clear	2.2	1.4	1.6
Actuations B4 Add *	0	0	-
Seconds / Actuation *	2.0	2.0	-
Max Initial *	40	40	-
Time Before Reduction *	15	15	-
Time To Reduce *	30	30	-
Minimum Gap	3.0	3.0	-
Locking Detector	X	X	-
Recall Position	VEH. RECALL	VEH. RECALL	-
Dual Entry	-	-	-
Simultaneous Gap	X	X	X

LEGEND

PROPOSED	EXISTING
	N/A
N/A	
(A)	(A) "YIELD" Sign (R1-2)
(B)	(B) Right Arrow "ONLY" Sign (R3-5R)
(C)	(C) Combined Through and Right Arrow Sign (R3-6R)
(D)	(D) Left Arrow "ONLY" Sign (R3-5L)
(E)	(E) "NO LEFT TURN" Sign (R3-2)
(F)	(F) Street Name Sign

* These values may be field adjusted. Do not adjust Min Green and Extension times for phases 2 and 6 lower than what is shown. Min Green for all other phases should not be lower than 4 seconds.

Signal Upgrade

DOCUMENT NOT CONSIDERED FINAL UNLESS ALL SIGNATURES COMPLETED

Prepared for the Offices of:
 Transportation Mobility and Safety Division
 NORTH CAROLINA DEPARTMENT OF TRANSPORTATION
 Signal Design Section
 750 N. Greenfield Pkwy, Garner, NC 27529

SR 1226 (University Drive) at I-40 EB-85 NB Ramps

Division 7 Alamance County Burlington
 PLAN DATE: March 2018 REVIEWED BY: PL Alexander
 PREPARED BY: NA Ptak REVIEWED BY: AM Encarnacion

SCALE: 1"=40'

DATE: 6/7/2018
 SIGNATURE: Pamela Alexander
 DATE: _____
 SIGNATURE: _____
 DATE: _____

SIG. INVENTORY NO. 07-1993

07-JUN-2018 11:15
 **wsatkins.com\proj\sr1226\I-40 EB-85 NB Ramps\Task 05-11_Signal Design\07-1993.dgn
 ALEX3361 AT LUS340649

EDI MODEL 2018ECLip-NC CONFLICT MONITOR PROGRAMMING DETAIL

(remove jumper and set switches as shown)

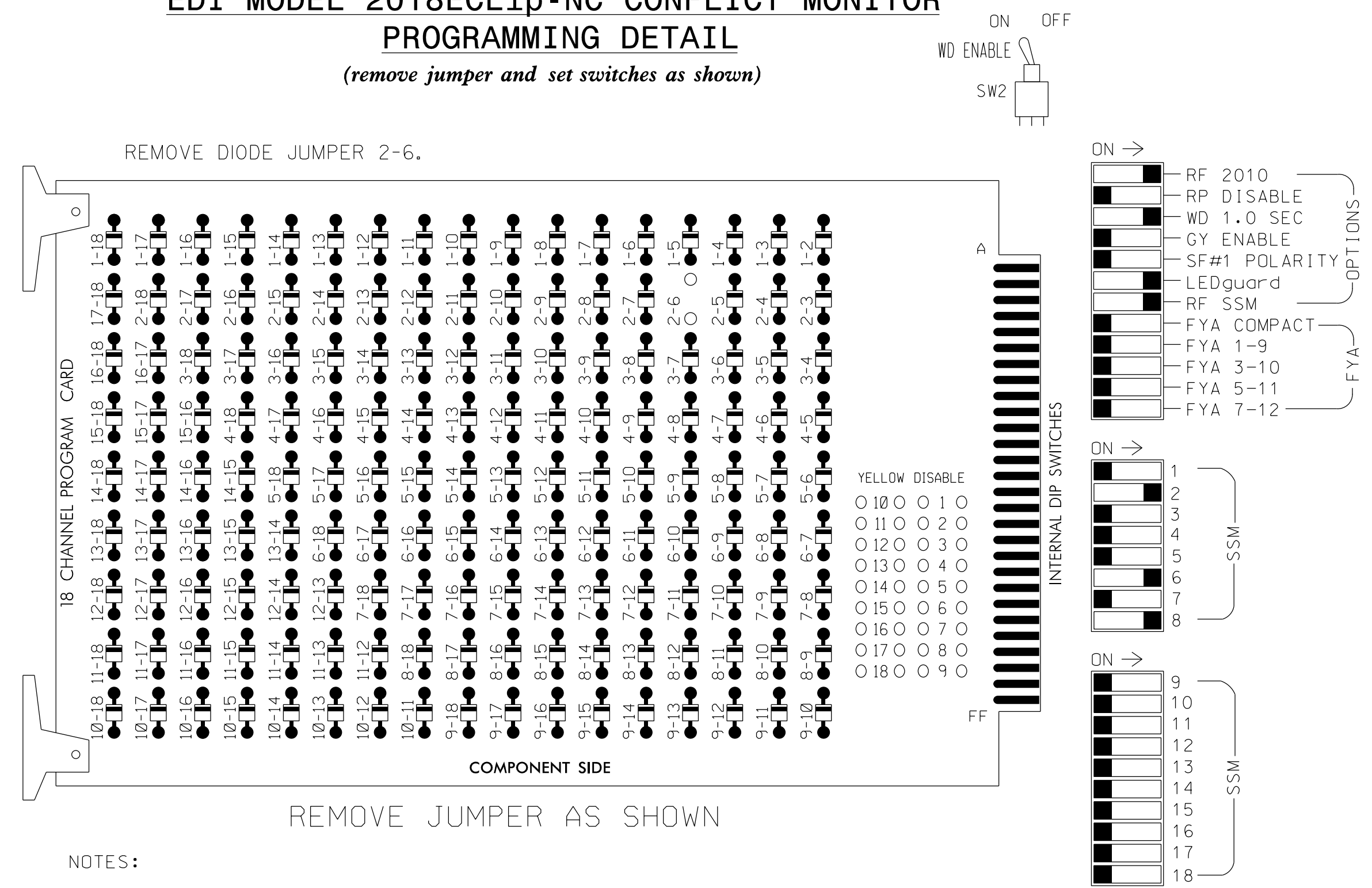

NOTES:

1. Card is provided with all diode jumpers in place. Removal of any jumper allows its channels to run concurrently.
2. Ensure jumpers SEL2-SEL5 and SEL9 are present on the monitor board.
3. Ensure that Red Enable is active at all times during normal operation.
4. Integrate monitor with Ethernet network in cabinet.

NOTES

1. To prevent "flash-conflict" problems, insert red flash program blocks for all unused vehicle load switches in the output file. The installer shall verify that signal heads flash in accordance with the Signal Plans.
2. Program controller to start up in phase 2 Green and 6 Green.
3. The cabinet and controller are part of the Burlington-Graham Signal System.

SIGNAL HEAD HOOK-UP CHART

LOAD SWITCH NO.	S1	S2	S3	S4	S5	S6	S7	S8	S9	S10	S11	S12	AUX S1	AUX S2	AUX S3	AUX S4	AUX S5	AUX S6
CMU CHANNEL NO.	1	2	13	3	4	14	5	6	15	7	8	16	9	10	17	11	12	18
PHASE	1	2	2 PED	3	4	4 PED	5	6	6 PED	7	8	8 PED	OLA	OLB	SPARE	OLC	OLD	SPARE
SIGNAL HEAD NO.	NU	21,22	NU	NU	NU	NU	NU	61,62	NU	NU	81,82,83	NU	NU	NU	NU	NU	NU	NU
RED		128						134			107							
YELLOW		129						135			108							
GREEN		130						136			109							
RED ARROW																		
YELLOW ARROW																		
GREEN ARROW																		

NU = Not Used

EQUIPMENT INFORMATION

CONTROLLER.....2070LX
 CABINET.....332 W/AUX
 SOFTWARE.....ECONOLITE ASC/3-2070
 CABINET MOUNT.....BASE
 OUTPUT FILE POSITIONS...18 WITH AUX. OUTPUT FILE
 LOAD SWITCHES USED.....S2,S8,S11
 PHASES USED.....2,6,8
 OVERLAPS.....NONE

INPUT FILE POSITION LAYOUT

(front view)

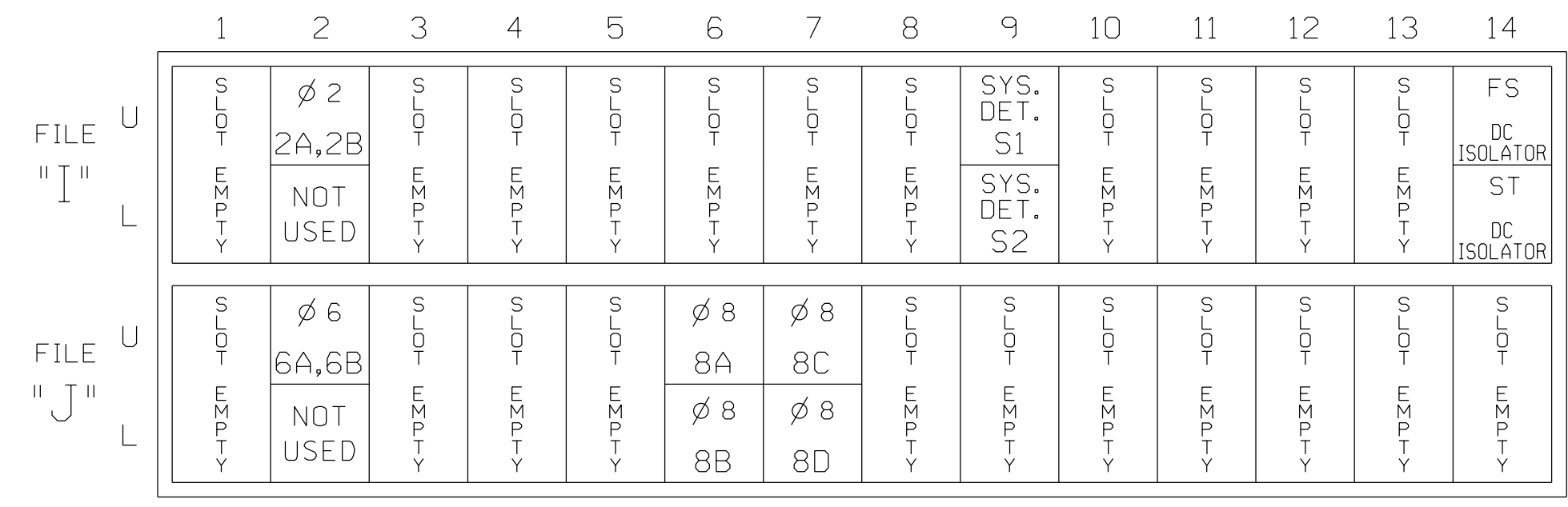

EX. : 1A, 2A, ETC. = LOOP NO.'S

FS = FLASH SENSE
 ST = STOP TIME

INPUT FILE CONNECTION & PROGRAMMING CHART

LOOP NO.	LOOP TERMINAL	INPUT FILE POS.	PIN NO.	DETECTOR NO.	NEMA PHASE	CALL	EXTEND TIME	DELAY TIME	ADDED INITIAL	DETECTOR TYPE
2A,2B	TB2-5,6	I2U	39	2	2	YES	1.0		X	N
* S1	TB6-9,10	I9U	60	11	SYS	NO				N
* S2	TB6-11,12	I9L	62	13	SYS	NO				N
6A,6B	TB3-5,6	J2U	40	6	6	YES	1.0		X	N
8A	TB5-9,10	J6U	42	8	8	YES				S
8B	TB5-11,12	J6L	46	18	8	YES				S
8C	TB7-1,2	J7U	66	38	8	YES		10		S
8D	TB7-3,4	J7L	79	48	8	YES		15		S

* System detector only. Remove any assigned vehicle phase.

INPUT FILE POSITION LEGEND:

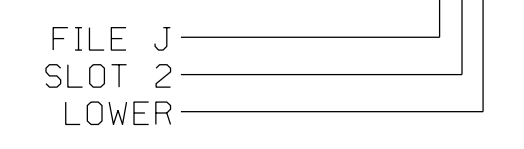

THIS ELECTRICAL DETAIL IS FOR THE SIGNAL DESIGN: 07-1993
 DESIGNED: March 2018
 SEALED: 6/7/2018
 REVISED: N/A

Electrical Detail

DOCUMENT NOT CONSIDERED FINAL UNLESS ALL SIGNATURES COMPLETED

Electrical and Programming Details for:
 SR 1226 (University Drive) at I-40 EB-85 NB Ramps

Division 7 Alamance County Burlington

PLAN DATE: March 2018 REVIEWED BY: PL Alexander
 PREPARED BY: NA Ptak REVIEWED BY: AM Encarnacion

REVISIONS: INIT. DATE

6/9/2018
 PAMELA L. ALEXANDER
 SEAL 023489
 SIG. INVENTORY NO. 07-1993

PHASING DIAGRAM

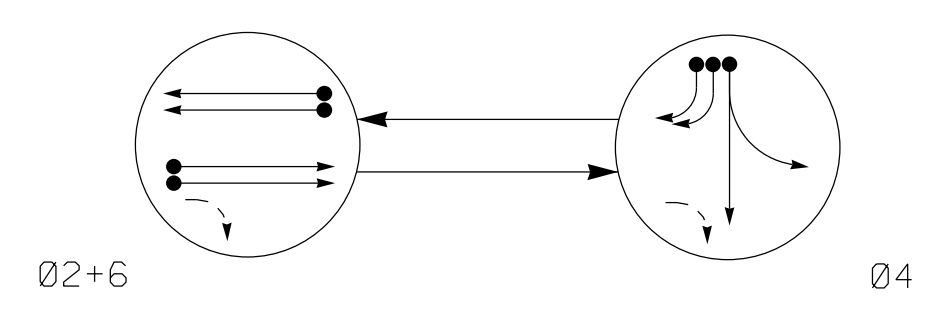

PHASING DIAGRAM DETECTION LEGEND

- DETECTED MOVEMENT
- ← UNDETECTED MOVEMENT (OVERLAP)
- ⋯ UNSIGNALIZED MOVEMENT
- ⇄ PEDESTRIAN MOVEMENT

TABLE OF OPERATION

SIGNAL FACE	PHASE		
	02+6	04	FLASH
21,22	G	R	Y
41,42	R	G	R
61,62	G	R	Y

SIGNAL FACE I.D.

All Heads L.E.D.

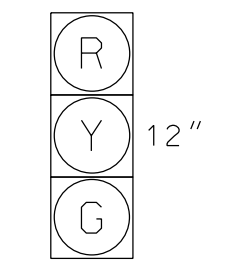

21,22
41,42
61,62

ASC/3 DETECTOR INSTALLATION CHART

LOOP	SIZE (FT)	DISTANCE FROM STOPBAR (FT)	TURNS	NEW LOOP	PHASE	PROGRAMMING						
						CALLING	EXTEND TIME	DELAY TIME	USE ADDED INITIAL	TYPE	LOOP	NEW CARD
2A,2B	6X6	360	EXIST	-	2	Yes	0.5	-	X	N	-	X
4A	6X40	0	2-4-2	-	4	Yes	-	-	-	S	-	X
4B	6X40	0	2-4-2	-	4	Yes	-	15	-	S	-	X
4C	6X40	0	2-4-2	-	4	Yes	-	15	-	S	-	X
6A,6B	6X6	360	EXIST	-	6	Yes	0.5	-	X	N	-	X
S1	6X6	+90	3	X	-	No	-	-	-	N	X	X
S2	6X6	+90	3	X	-	No	-	-	-	N	X	X

2 Phase Fully Actuated (Burlington-Graham Signal System)

NOTES

- Refer to "Roadway Standard Drawings NCDOT" dated January 2018 and "Standard Specifications for Roads and Structures" dated January 2018.
- Do not program signal for late night flashing operation unless otherwise directed by Engineer.
- Set all detector units to presence mode.
- In the event of loop replacement, refer to the current ITS and Signals Design Manual and submit a Plan of Record to the Signal Design Section.
- Locate new cabinet so as not to obstruct sight distance of vehicles turning right on red.
- The cabinet should be designed to include an Auxiliary Output File for future use.
- Pavement markings are existing.
- Maximum times shown in timing chart are for free-run operation only. Coordinated signal system timing values supersede these values.

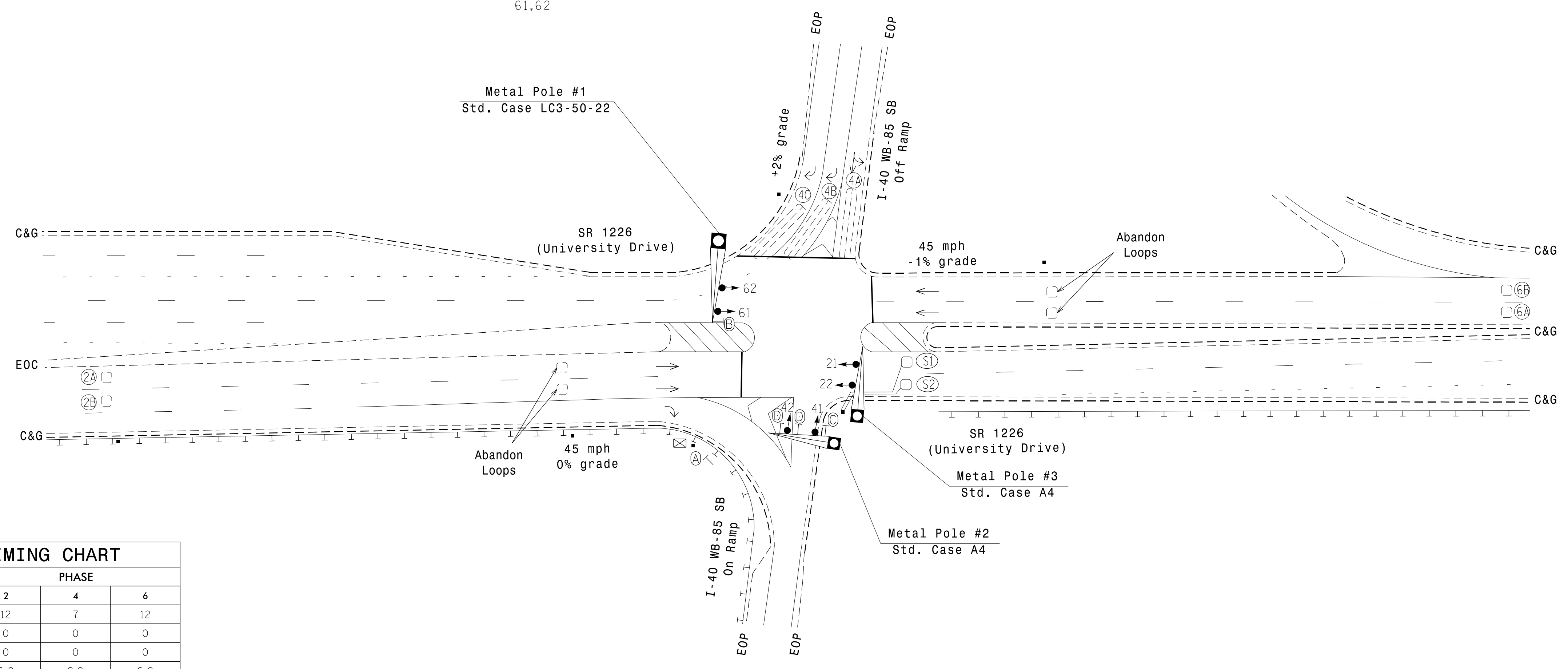

LEGEND

- | PROPOSED | EXISTING |
|--|---------------------------------|
| ○ → Traffic Signal Head | ○ → N/A |
| ● → Modified Signal Head | ● → N/A |
| ⊥ Sign | ⊥ |
| ⊥ Pedestrian Signal Head | ⊥ |
| ○ Signal Pole with Guy | ○ Signal Pole with Sidewalk Guy |
| ⊥ Metal Pole with Mastarm | ⊥ Inductive Loop Detector |
| ⊥ Controller & Cabinet | ⊥ Junction Box |
| ⊥ 2-in Underground Conduit | ⊥ Right of Way |
| → Directional Arrow | → |
| (A) "YIELD" Sign (R1-2) | (A) |
| (B) "NO LEFT TURN" Sign (R3-2) | (B) |
| (C) Combined Through and Left Arrow Sign (R3-6L) | (C) |
| (D) Right Arrow "ONLY" Sign (R3-5R) | (D) |

ASC/3 TIMING CHART

FEATURE	PHASE		
	2	4	6
Min Green *	12	7	12
Walk *	0	0	0
Ped Clear	0	0	0
Veh. Extension *	6.0	2.0	6.0
Max 1 *	90	30	90
Yellow	4.5	3.7	4.6
Red Clear	1.0	1.7	1.3
Actuations B4 Add *	0	-	0
Seconds / Actuation *	2.0	-	2.0
Max Initial *	40	-	40
Time Before Reduction *	15	-	15
Time To Reduce *	30	-	30
Minimum Gap	3.0	-	3.0
Locking Detector	X	-	X
Recall Position	VEH. RECALL	-	VEH. RECALL
Dual Entry	-	-	-
Simultaneous Gap	X	X	X

* These values may be field adjusted. Do not adjust Min Green and Extension times for phases 2 and 6 lower than what is shown. Min Green for all other phases should not be lower than 4 seconds.

Signal Upgrade

DOCUMENT NOT CONSIDERED FINAL UNLESS ALL SIGNATURES COMPLETED

750 N. Greenfield Pkwy, Garner, NC 27529

SR 1226 (University Drive) at I-40 WB-85 SB Ramps

Division 7 Alamance County Burlington

PLAN DATE: February 2018 REVIEWED BY: PL Alexander

PREPARED BY: NA Ptak REVIEWED BY: AM Encarnacion

6/7/2018

DATE

SIG. INVENTORY NO. 07-1994

SCALE: 0 40
1" = 40'

ATKINS 1616 EAST MILLBROOK ROAD, SUITE 160
RALEIGH, NORTH CAROLINA 27609
(919) 876-6888 NCBES #F-0326

07-JUN-2018 11:15 U:\Projects\Traffic\Traffic\Task 05_11_Signal\Design\Task 07-1994.dgn ALEX3361 AT LUS340649

EDI MODEL 2018ECLip-NC CONFLICT MONITOR PROGRAMMING DETAIL

(remove jumper and set switches as shown)

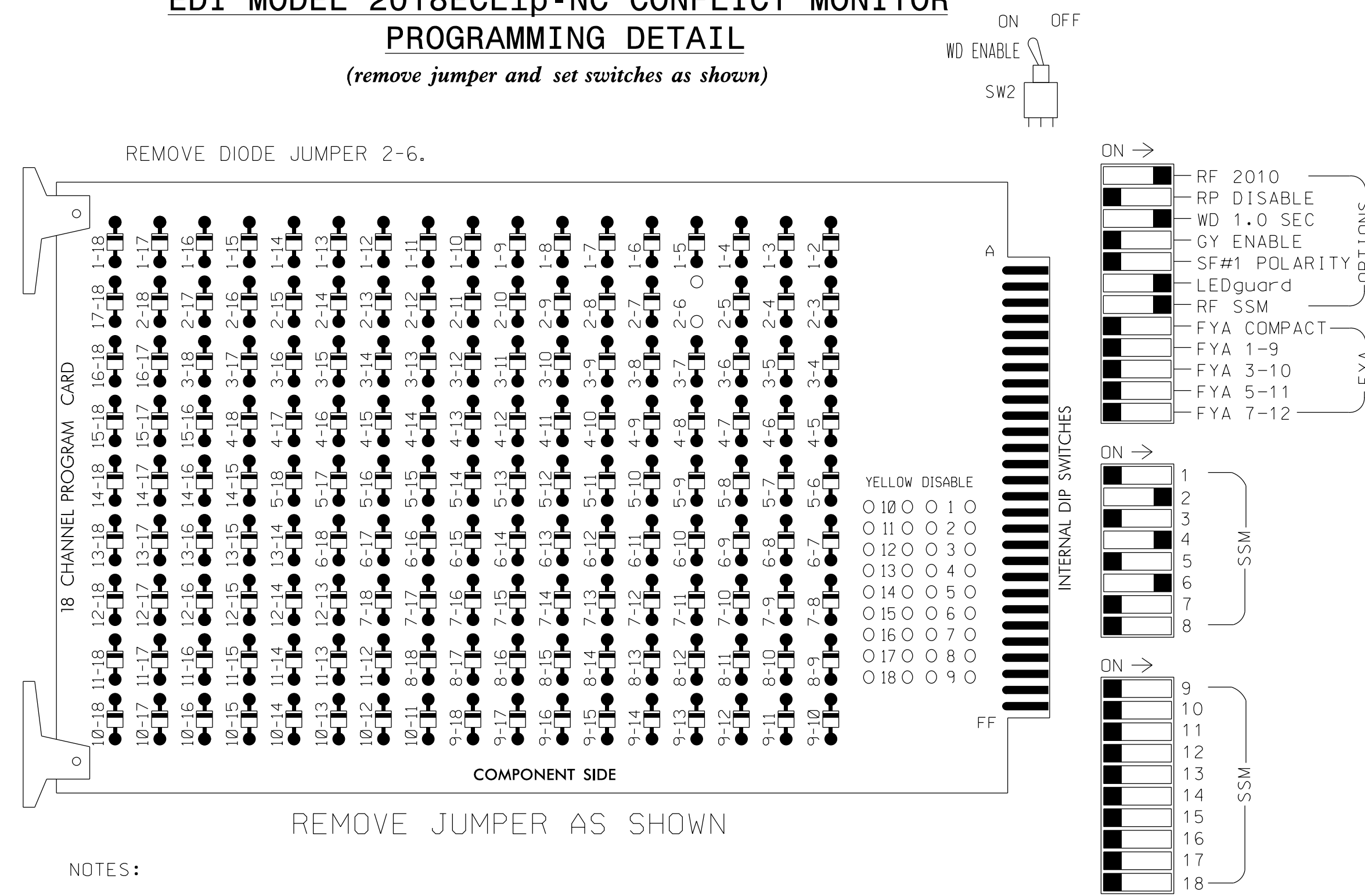

NOTES:

1. Card is provided with all diode jumpers in place. Removal of any jumper allows its channels to run concurrently.
2. Ensure jumpers SEL2-SEL5 and SEL9 are present on the monitor board.
3. Ensure that Red Enable is active at all times during normal operation.
4. Integrate monitor with Ethernet network in cabinet.

NOTES

1. To prevent "flash-conflict" problems, insert red flash program blocks for all unused vehicle load switches in the output file. The installer shall verify that signal heads flash in accordance with the Signal Plans.
2. Program controller to start up in phase 2 Green and 6 Green.
3. The cabinet and controller are part of the Burlington-Graham Signal System.

EQUIPMENT INFORMATION

CONTROLLER.....2070LX
 CABINET.....332 W/AUX
 SOFTWARE.....ECONOLITE ASC/3-2070
 CABINET MOUNT.....BASE
 OUTPUT FILE POSITIONS...18 WITH AUX. OUTPUT FILE
 LOAD SWITCHES USED.....S2,S5,S8
 PHASES USED.....2,4,6
 OVERLAPS.....NONE

PROJECT REFERENCE NO.	SHEET NO.
U-6015	Fig. 151.1

SIGNAL HEAD HOOK-UP CHART

LOAD SWITCH NO.	S1	S2	S3	S4	S5	S6	S7	S8	S9	S10	S11	S12	AUX S1	AUX S2	AUX S3	AUX S4	AUX S5	AUX S6
CMU CHANNEL NO.	1	2	13	3	4	14	5	6	15	7	8	16	9	10	17	11	12	18
PHASE	1	2	2 PED	3	4	4 PED	5	6	6 PED	7	8	8 PED	OLA	OLB	SPARE	OLC	OLD	SPARE
SIGNAL HEAD NO.	NU	21,22	NU	NU	41,42	NU	NU	61,62	NU	NU	NU	NU	NU	NU	NU	NU	NU	NU
RED		128			101			134										
YELLOW		129			102			135										
GREEN		130			103			136										
RED ARROW																		
YELLOW ARROW																		
GREEN ARROW																		

NU = Not Used

INPUT FILE POSITION LAYOUT

(front view)

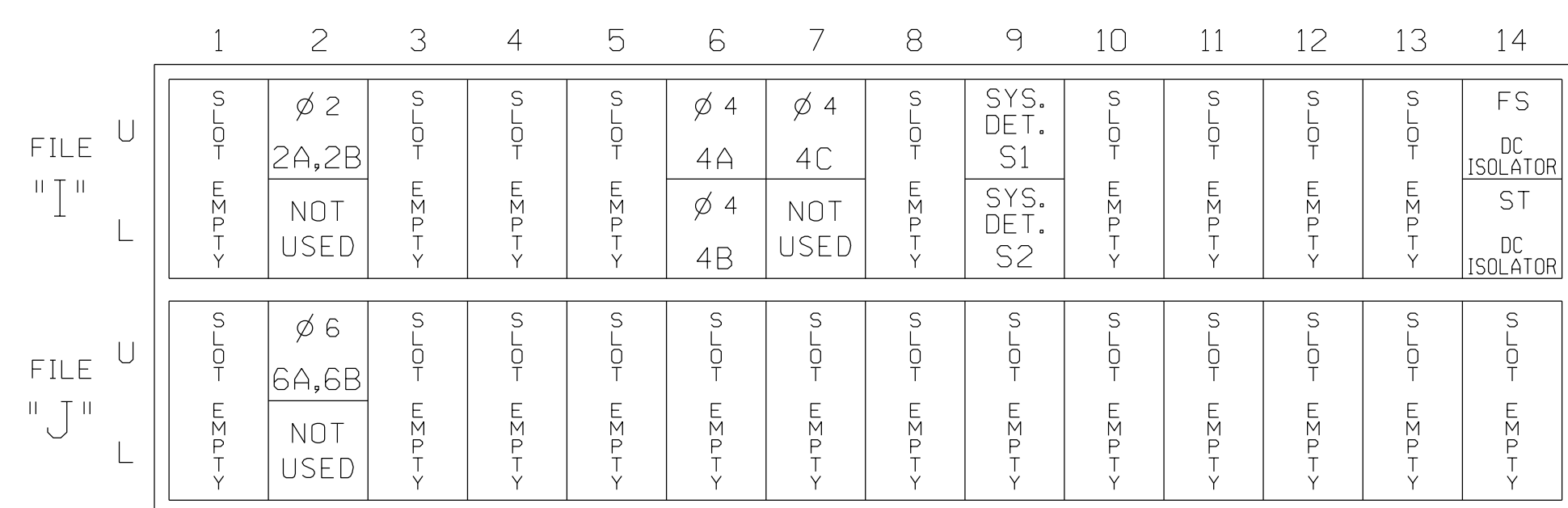

EX. : 1A, 2A, ETC. = LOOP NO.'S

FS = FLASH SENSE
 ST = STOP TIME

INPUT FILE CONNECTION & PROGRAMMING CHART

LOOP NO.	LOOP TERMINAL	INPUT FILE POS.	PIN NO.	DETECTOR NO.	NEMA PHASE	CALL	EXTEND TIME	DELAY TIME	ADDED INITIAL	DETECTOR TYPE
2A,2B	TB2-5,6	I2U	39	2	2	YES	0.5		X	N
4A	TB4-9,10	I6U	41	4	4	YES				S
4B	TB4-11,12	I6L	45	14	4	YES		15		S
4C	TB6-1,2	I7U	65	34	4	YES		15		S
* S1	TB6-9,10	I9U	60	11	SYS	NO				N
* S2	TB6-11,12	I9L	62	13	SYS	NO				N
6A,6B	TB3-5,6	J2U	40	6	6	YES	0.5		X	N

* System detector only. Remove any assigned vehicle phase.

INPUT FILE POSITION LEGEND: J2L

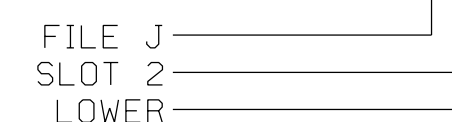

THIS ELECTRICAL DETAIL IS FOR THE SIGNAL DESIGN: 07-1994
 DESIGNED: February 2018
 SEALED: 6/7/2018
 REVISED: N/A

09-JUN-2018 14:15 D:\P\consort\at\work\office\cur\100056469 U-6015 B-G S1g Sys\Task 05_11_Signal\Des\gmr\1r\ing07-1994E.dgn ALEX3361 AT LUS210649

Electrical Detail

ELECTRICAL AND PROGRAMMING DETAILS FOR:

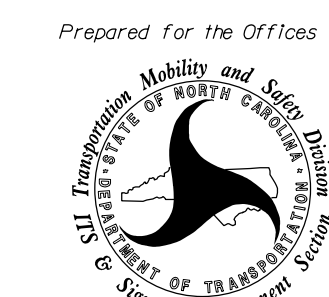

SR 1226 (University Drive) at I-40 WB-85 SB Ramps

Division 7 Alamance County Burlington
 PLAN DATE: February 2018 REVIEWED BY: PL Alexander
 PREPARED BY: NA Ptak REVIEWED BY: AM Encarnacion

REVISIONS	INIT.	DATE

DOCUMENT NOT CONSIDERED FINAL UNLESS ALL SIGNATURES COMPLETED

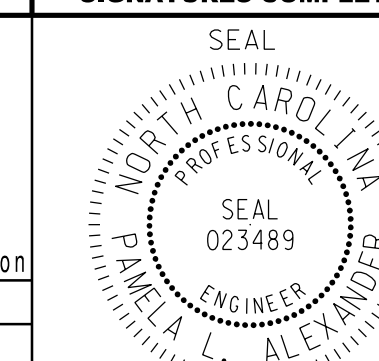

Checked by: Pamela Alexander DATE: 6/9/2018
 Drawn by: DATE:
 SIG. INVENTORY NO. 07-1994

ATKINS 1616 EAST MILLBROOK ROAD, SUITE 160
 RALEIGH, NORTH CAROLINA 27609
 (919) 876-6888 NCBES #F-0326

EDI MODEL 2018EClip-NC CONFLICT MONITOR PROGRAMMING DETAIL

(remove jumpers and set switches as shown)

REMOVE DIODE JUMPERS 1-5, 1-6, 1-9, 1-12, 2-5, 2-6, 2-12, 3-7, 3-8, 3-9, 3-12, 4-7, 4-8, 4-9, 4-12, 5-9, 6-9, 6-12, 7-12, 8-9, and 9-12.

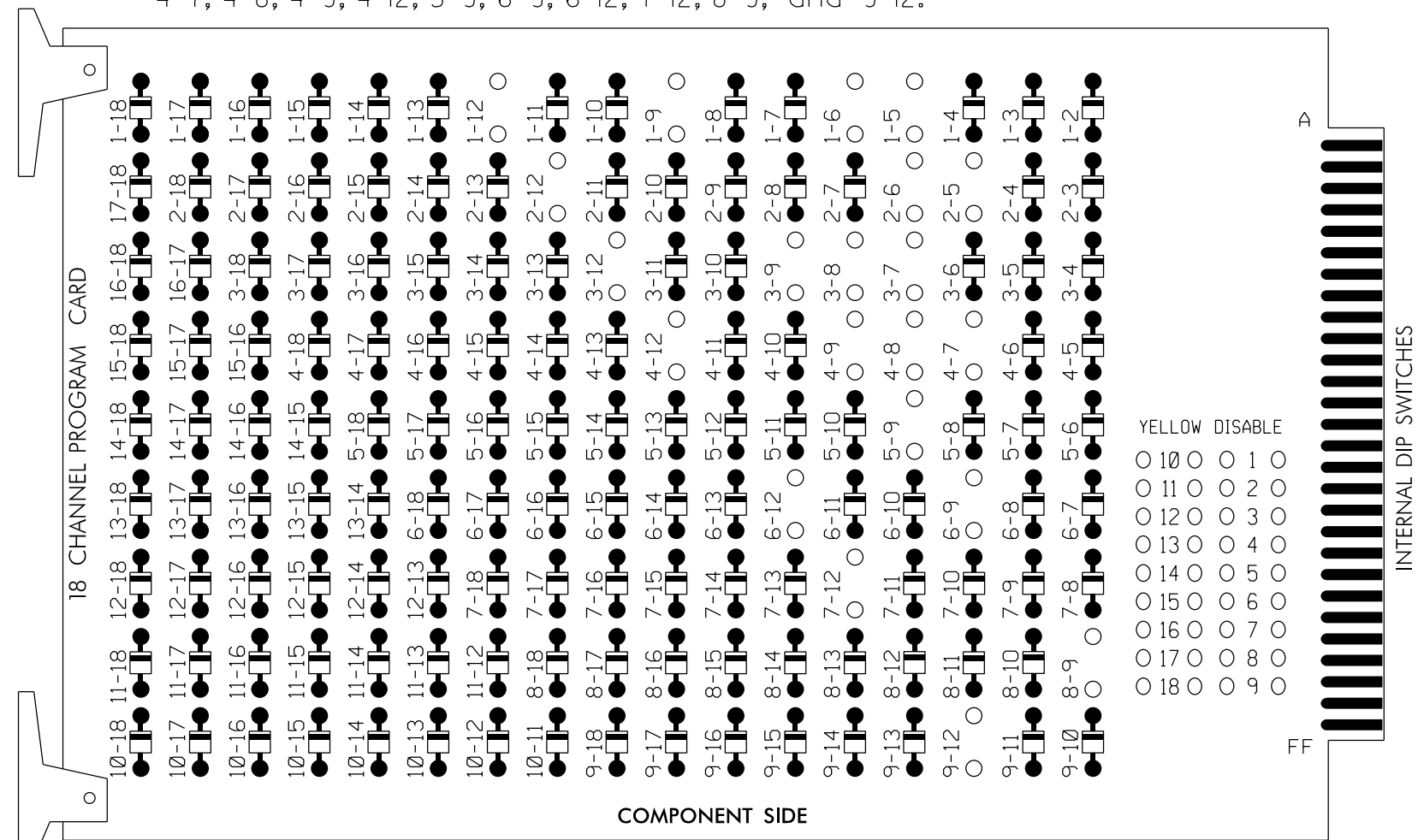

REMOVE JUMPERS AS SHOWN

NOTES:

- 1. Card is provided with all diode jumpers in place. Removal of any jumper allows its channels to run concurrently.
- 2. Ensure jumpers SEL2-SEL5 and SEL9 are present on the monitor board.
- 3. Ensure that Red Enable is active at all times during normal operation.
- 4. Integrate monitor with Ethernet network in cabinet.

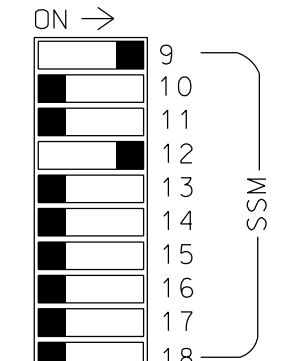
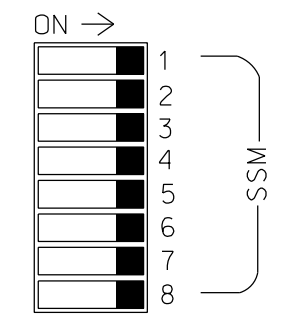
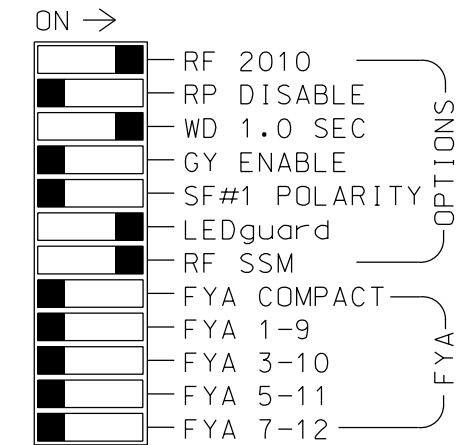
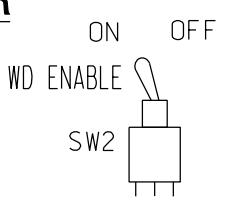

■ = DENOTES POSITION OF SWITCH

NOTES

- 1. To prevent "flash-conflict" problems, insert red flash program blocks for all unused vehicle load switches in the output file. The installer shall verify that signal heads flash in accordance with the Signal Plans.
- 2. Program controller to start up in phase 2 Green and 6 Green.
- 3. The cabinet and controller are part of the Burlington-Graham Signal System.

EQUIPMENT INFORMATION

CONTROLLER.....2070LX
 CABINET.....332 W/AUX
 SOFTWARE.....ECONOLITE ASC/3-2070
 CABINET MOUNT.....BASE
 OUTPUT FILE POSITIONS...18 WITH AUX. OUTPUT FILE
 LOAD SWITCHES USED.....S1,S2,S4,S5,S7,S8,S10,S11,
 AUX S1,AUX S5.
 PHASES USED.....1,2,3,4,5,6,7,8
 OVERLAP "A".....1+8
 OVERLAP "B".....NOT USED
 OVERLAP "C".....NOT USED
 OVERLAP "D".....6+7

SIGNAL HEAD HOOK-UP CHART

LOAD SWITCH NO.	S1	S2	S3	S4	S5	S6	S7	S8	S9	S10	S11	S12	AUX S1	AUX S2	AUX S3	AUX S4	AUX S5	AUX S6	
CMU CHANNEL NO.	1	2	13	3	4	14	5	6	15	7	8	16	9	10	17	11	12	18	
PHASE	1	2	2 PED	3	4	4 PED	5	6	6 PED	7	8	8 PED	OLA	OLB	SPARE	OLC	OLD	SPARE	
SIGNAL HEAD NO.	11,12	21,22	NU	31,32	41,42	NU	42	51,52	61,62	NU	71,72,73	81,82	NU	13,14	NU	NU	NU	63,64	NU
RED		128			101				134			107		A121				A101	
YELLOW		129			102				135			108							
GREEN		130			103				136			109							
RED ARROW	125				116				131			122							
YELLOW ARROW	126				117				132	132		123		A122				A102	
GREEN ARROW	127				118				133	133		124		A123				A103	

NU = Not Used

ECONOLITE ASC/3-2070 OVERLAP PROGRAMMING DETAIL

(program controller as shown)

- 1. From Main Menu select **2. CONTROLLER**
- 2. From CONTROLLER Submenu select **2. VEHICLE OVERLAPS**

OVERLAP A

Select TMG VEH OVLP [A] and 'NORMAL'

TMG VEH OVLP...[A] TYPE: [NORMAL]
 PHASES 1 2 3 4 5 6 7 8 9 0 1 2 3 4 5 6
 INCLUDED X X
 LAG GRN 0.0 YEL 0.0 RED 0.0

Toggle 3 Times

OVERLAP D

Select TMG VEH OVLP [D] and 'NORMAL'

TMG VEH OVLP...[D] TYPE: [NORMAL]
 PHASES 1 2 3 4 5 6 7 8 9 0 1 2 3 4 5 6
 INCLUDED X X
 LAG GRN 0.0 YEL 0.0 RED 0.0

END PROGRAMMING

THIS ELECTRICAL DETAIL IS FOR THE SIGNAL DESIGN: 07-1995
 DESIGNED: March 2018
 SEALED: 6/7/2018
 REVISED: N/A

INPUT FILE POSITION LAYOUT

(front view)

FILE "I"	1	2	3	4	5	6	7	8	9	10	11	12	13	14
∅ 1	∅ 1	∅ 2	∅ 3	∅ 3	∅ 4	∅ 4	∅ 4	SYS. DET. S1	S	S	S	S	S	FS
1A	1C	2A,2B	3A	3B	4A	4B	4B	SYS. DET. S2	S	S	S	S	S	DC ISOLATOR
∅ 1	∅ 1	NOT USED	NOT USED	NOT USED	∅ 4	∅ 4	∅ 4	∅ 4	∅ 4	∅ 4	∅ 4	∅ 4	∅ 4	ST
1B	1D				4B	4B	4B	4B	4B	4B	4B	4B	4B	DC ISOLATOR
FILE "J"	∅ 5	∅ 5	∅ 6	∅ 7	∅ 7	∅ 8	∅ 8	SYS. DET. S3	S	S	S	S	S	S
	5A	5B	6A,6B	7A	7B	8A	8A	NOT USED	S	S	S	S	S	S
	NOT USED	∅ 5	NOT USED	NOT USED	∅ 7	∅ 8	∅ 8	∅ 8	∅ 8	∅ 8	∅ 8	∅ 8	∅ 8	∅ 8
	5C			7C	8B	8B	8B	8B	8B	8B	8B	8B	8B	8B

EX. : 1A, 2A, ETC. = LOOP NO.*

FS = FLASH SENSE
ST = STOP TIME

INPUT FILE CONNECTION & PROGRAMMING CHART

LOOP NO.	LOOP TERMINAL	INPUT FILE POS.	PIN NO.	DETECTOR NO.	NEMA PHASE	CALL	EXTEND TIME	DELAY TIME	ADDED INITIAL	DETECTOR TYPE
1A	TB2-1,2	I1U	56	1	J	YES				S
1B	TB2-3,4	I1L	56	1	I	YES				S
1C	TB2-5,6	I2U	39	2	I	YES		15		S
1D	TB2-7,8	I2L	43	12	I	YES		15		S
2A,2B	TB2-9,10	I3U	63	32	2	YES	0.8		X	S
3A	TB4-5,6	I5U	58	3	3	YES				S
3B	TB4-9,10	I6U	41	4	3	YES				S
4A	TB6-1,2	I7U	65	34	4	YES				S
4B	TB6-3,4	I7L	78	44	4	YES				S
* S1	TB6-9,10	I9U	60	11	SYS	NO				N
* S2	TB6-11,12	I9L	62	13	SYS	NO				N
5A	TB3-1,2	J1U	55	5	5	YES				S
5B	TB3-5,6	J2U	40	6	5	YES				S
5C	TB3-7,8	J2L	44	16	5	YES		15		S
6A,6B	TB3-9,10	J3U	64	36	6	YES	0.8		X	N
7A	TB5-5,6	J5U	57	7	7	YES				S
7B	TB5-9,10	J6U	42	8	7	YES				S
7C	TB5-11,12	J6L	46	18	7	YES				S
8A	TB7-1,2	J7U	66	38	8	YES				S
8B	TB7-3,4	J7L	79	40	8	YES				S
* S3	TB7-9,10	J9U	59	15	SYS	NO				N

* System detector only. Remove any assigned vehicle phase.

INPUT FILE POSITION LEGEND: J2L

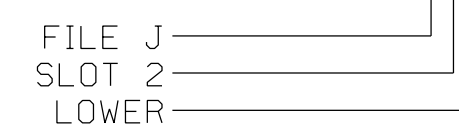

FLASHER CIRCUIT MODIFICATION DETAIL

IN ORDER TO ENSURE THAT SIGNALS FLASH CONCURRENTLY ON THE SAME APPROACH, MAKE THE FOLLOWING FLASHER CIRCUIT CHANGES:

- 1. ON REAR OF PDA - REMOVE WIRE FROM TERM. T2-4 AND TERMINATE ON T2-2.
- 2. ON REAR OF PDA - REMOVE WIRE FROM TERM. T2-5 AND TERMINATE ON T2-3.
- 3. REMOVE FLASHER UNIT 2.

THE CHANGES LISTED ABOVE TIES ALL PHASES AND OVERLAPS TO FLASHER UNIT 1.

Electrical Detail

ELECTRICAL AND PROGRAMMING DETAILS FOR:

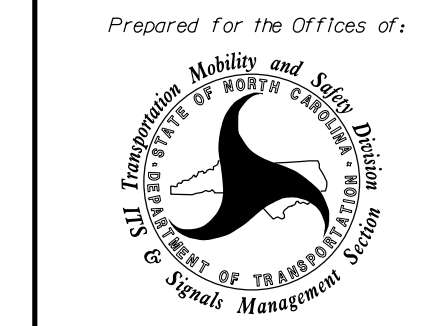

SR 1226 (University Drive) at SR 1301 (Boone Station Drive)/ University Commons Shopping Center	
Division 7	Alamance County
PLAN DATE: March 2018	REVIEWED BY: AM Encarnacion
PREPARED BY: NA Ptak	REVIEWED BY: PL Alexander
REVISIONS	INIT. DATE

DOCUMENT NOT CONSIDERED FINAL UNLESS ALL SIGNATURES COMPLETED

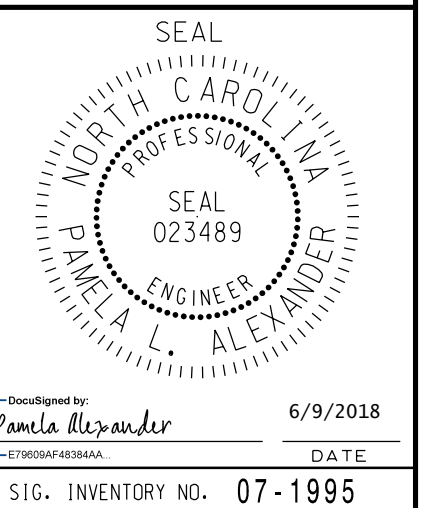

SIG. INVENTORY NO. 07-1995

PHASING DIAGRAM

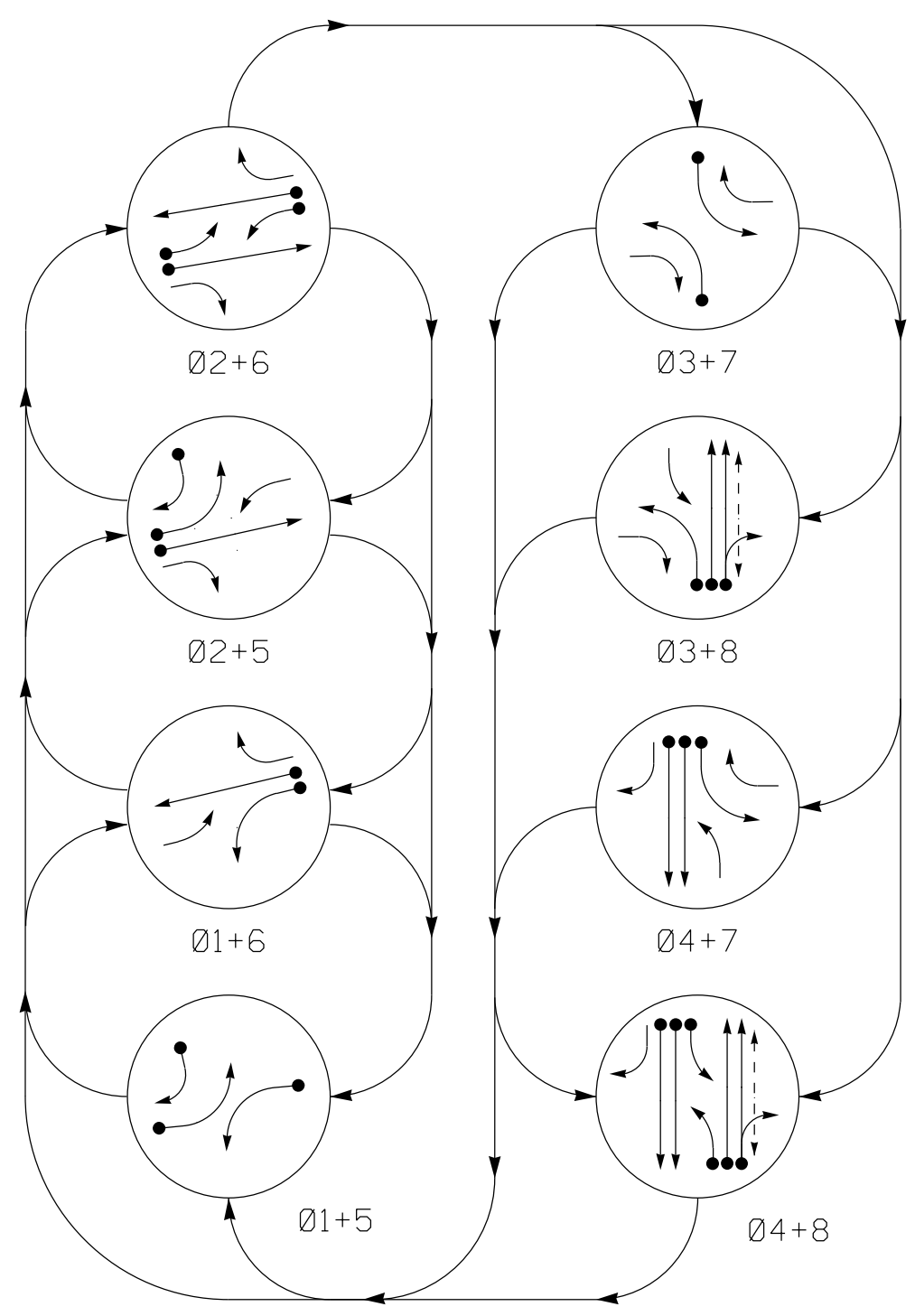

PHASING DIAGRAM DETECTION LEGEND

- ←● DETECTED MOVEMENT
- ← UNDETECTED MOVEMENT (OVERLAP)
- ← UNSIGNALIZED MOVEMENT
- ← PEDESTRIAN MOVEMENT

TABLE OF OPERATION

SIGNAL FACE	PHASE							
	01+5	02+6	03+7	04+8	01+6	02+5	03+8	04+7
11	←	←	←	←	←	←	←	←
21	R	R	G	G	R	R	R	Y
22	R	R	G	G	R	R	R	Y
31	←	←	←	←	←	←	←	←
41	R	R	R	R	R	R	R	G
42	R	R	R	R	R	R	R	G
51	←	←	←	←	←	←	←	←
61	R	G	R	G	R	R	R	Y
62	R	G	R	G	R	R	R	Y
71	←	←	←	←	←	←	←	←
81, 82	R	R	R	R	R	R	R	G
P81, P82	DW	DW	DW	DW	DW	W	DW	DRK

SIGNAL FACE I.D.

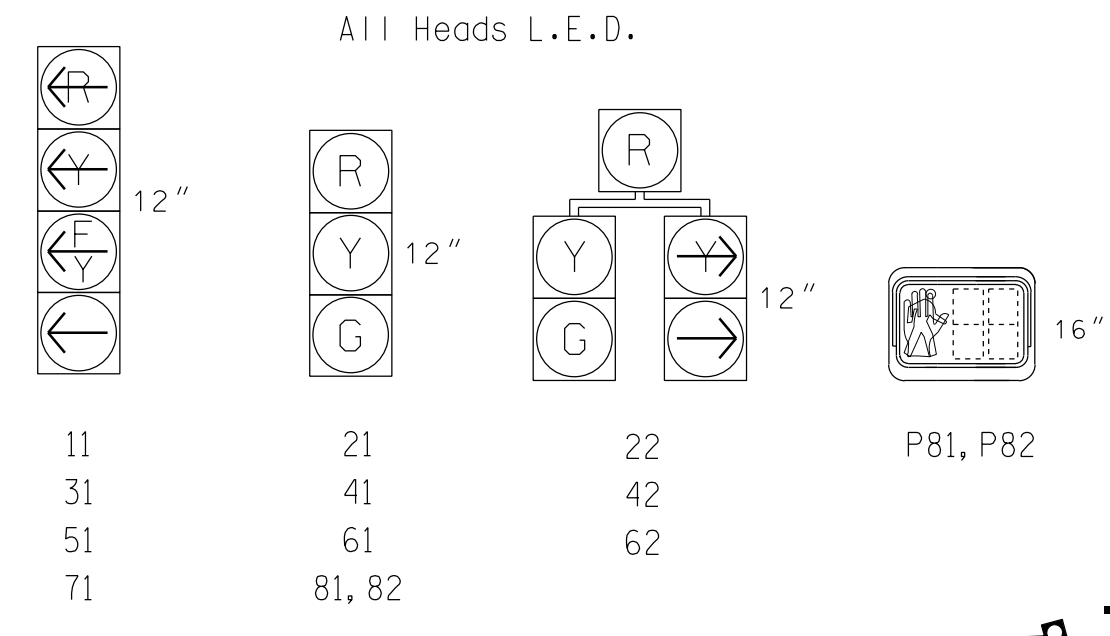

ASC/3 DETECTOR INSTALLATION CHART

LOOP	SIZE (FT)	DISTANCE FROM STOPBAR (FT)	TURNS	NEW LOOP	PROGRAMMING							
					PHASE	CALLING	EXTEND TIME	DELAY TIME	USE ADDED INITIAL	TYPE	SYSTEM LOOP	NEW CARD
1A	6X60	0	2-4-2	-	1	Yes	-	15	-	S	-	X
2A	6X6	420	EXIST	-	2	Yes	-	-	-	X	N	-
3A	6X60	0	2-4-2	-	3	Yes	-	15	-	S	-	X
4A, 4B	6X6	300	EXIST	-	4	No	3.1	-	-	S	-	X
4C	6X60	0	2-4-2	-	4	Yes	-	-	-	S	-	X
4D	6X60	0	2-4-2	-	4	Yes	-	-	-	S	-	X
5A	6X60	0	2-4-2	-	5	Yes	-	15	-	S	-	X
5B	6X60	0	2-4-2	-	5	Yes	-	15	-	S	-	X
6A	6X6	420	EXIST	-	6	Yes	-	-	-	X	N	-
7A	6X60	0	2-4-2	-	7	Yes	-	15	-	S	-	X
8A, 8B	6X6	300	EXIST	-	8	No	3.1	-	-	S	-	X
8C	6X60	0	2-4-2	-	8	Yes	-	-	-	S	-	X
8D	6X60	0	2-4-2	-	8	Yes	-	10	-	S	-	X
S1	6X6	+130	EXIST	-	-	No	-	-	-	N	X	X

8 Phase Fully Actuated (Burlington-Graham Signal System)

NOTES

- Refer to "Roadway Standard Drawings NCDOT" dated January 2018 and "Standard Specifications for Roads and Structures" dated January 2018.
- Do not program signal for late night flashing operation unless otherwise directed by the Engineer.
- Phase 1 and/or 5 may be lagged.
- Phase 3 and/or 7 may be lagged.
- Set all detector units to presence mode.
- In the event of loop replacement, refer to the current ITS and Signals Design Manual and submit a Plan of Record to the Signal Design Section.
- Locate new cabinet so as not to obstruct sight distance of vehicles turning right on red.
- Omit "WALK" and flashing "DON'T WALK" with no pedestrian calls.
- Program pedestrian heads to countdown the flashing "Don't Walk" time only.
- Pavement markings are existing.
- Maximum times shown in timing chart are for free-run operation only. Coordinated signal system supersede these values.

ASC/3 TIMING CHART

FEATURE	PHASE							
	1	2	3	4	5	6	7	8
Min Green *	7	14	7	7	7	14	7	7
Walk *	0	0	0	0	0	0	0	4
Ped Clear	0	0	0	0	0	0	0	29
Veh. Extension *	2.0	6.0	2.0	1.0	2.0	6.0	2.0	2.0
Max I *	30	90	30	50	25	90	20	50
Yellow	3.0	5.2	3.0	4.7	3.0	5.2	3.0	4.7
Red Clear	3.7	2.3	3.3	2.0	3.9	2.3	2.8	2.0
Actuations B4 Add *	-	0	-	-	-	0	-	-
Seconds / Actuation *	-	2.5	-	-	-	2.5	-	-
Max Initial *	-	46	-	-	-	46	-	-
Time Before Reduction *	-	15	-	-	-	15	-	-
Time To Reduce *	-	30	-	-	-	30	-	-
Minimum Gap	-	3.4	-	-	-	3.4	-	-
Locking Detector	-	X	-	-	-	X	-	-
Recall Position	-	VEH. RECALL	-	-	-	VEH. RECALL	-	-
Dual Entry	-	-	-	X	-	-	-	X
Simultaneous Gap	X	X	X	X	X	X	X	X

* These values may be field adjusted. Do not adjust Min Green and Extension times for phases 2 and 6 lower than what is shown. Min Green for all other phases should not be lower than 4 seconds.

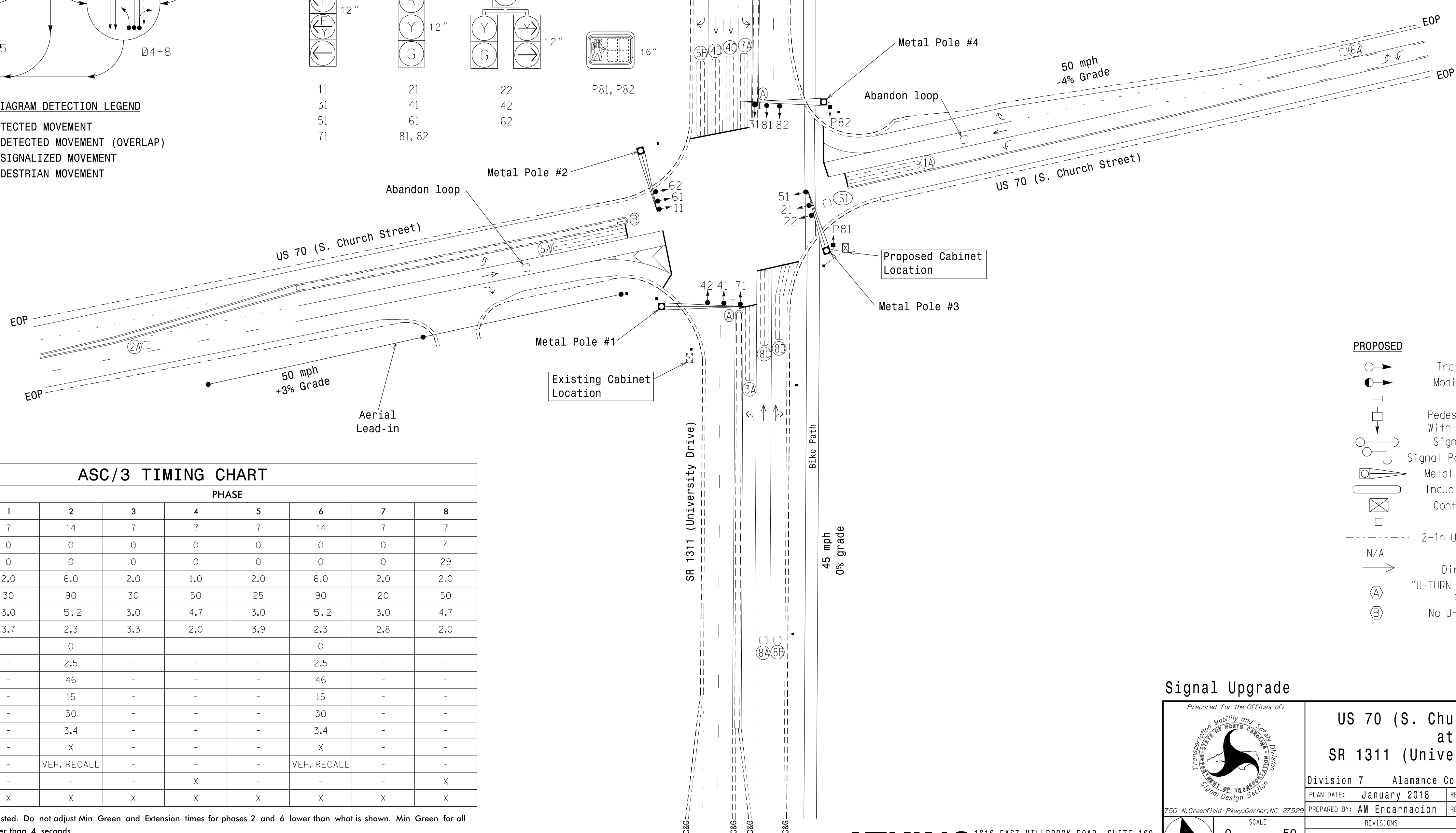

LEGEND

PROPOSED	EXISTING
○ → Traffic Signal Head	● → N/A
○ → Modified Signal Head	○ → Sign
○ → Pedestrian Signal Head	○ → Sign
○ → Signal Pole with Guy	○ → Sign
○ → Signal Pole with Sidewalk Guy	○ → Sign
○ → Metal Pole with Mastarm	○ → Sign
○ → Inductive Loop Detector	○ → Sign
○ → Controller & Cabinet	○ → Sign
○ → Junction Box	○ → Sign
○ → 2-in Underground Conduit	○ → Sign
○ → Right of Way	○ → Sign
○ → Directional Arrow	○ → Sign
○ → "U-TURN YIELD TO RIGHT TURN" Sign (R10-16)	○ → Sign
○ → No U-Turn Sign (R3-4)	○ → Sign

Signal Upgrade

Prepared for the Offices of:

US 70 (S. Church Street) at SR 1311 (University Drive)

Division 7 Alamance County Burlington

PLAN DATE: January 2018 REVIEWED BY: PL Alexander

PREPARED BY: AM Encarnacion REVIEWED BY:

REVISIONS: INIT. DATE

SCALE: 1"=50'

0 50

ATKINS 1616 EAST MILLBROOK ROAD, SUITE 160 RALEIGH, NORTH CAROLINA 27609 (919) 876-6888 NCBEES #F-0326

DOCUMENT NOT CONSIDERED FINAL UNLESS ALL SIGNATURES COMPLETED

SEAL: PAMELA L. ALEXANDER, PROFESSIONAL ENGINEER, 023489, 6/7/2018

SIG. INVENTORY NO. 07-1996

07-JUN-2018 11:15 D:\Fonsior\at\work\offices\cur\10056469 U-6015 B-G S1g Sys\Task 05_11_Signal\Des\gsm07-1996.dgn ALEX3361 AT LUS30649

EDI MODEL 2018EClip-NC CONFLICT MONITOR PROGRAMMING DETAIL

(remove jumpers and set switches as shown)
 REMOVE DIODE JUMPERS 1-5, 1-6, 1-9, 1-11, 2-5, 2-6, 2-9, 2-11, 3-7, 3-8, 3-10, 3-12, 3-16, 4-7, 4-8, 4-10, 4-12, 4-16, 5-9, 5-11, 6-9, 6-11, 7-10, 7-12, 8-10, 8-12, 8-16, 9-11, 10-12, 10-16 and 12-16.

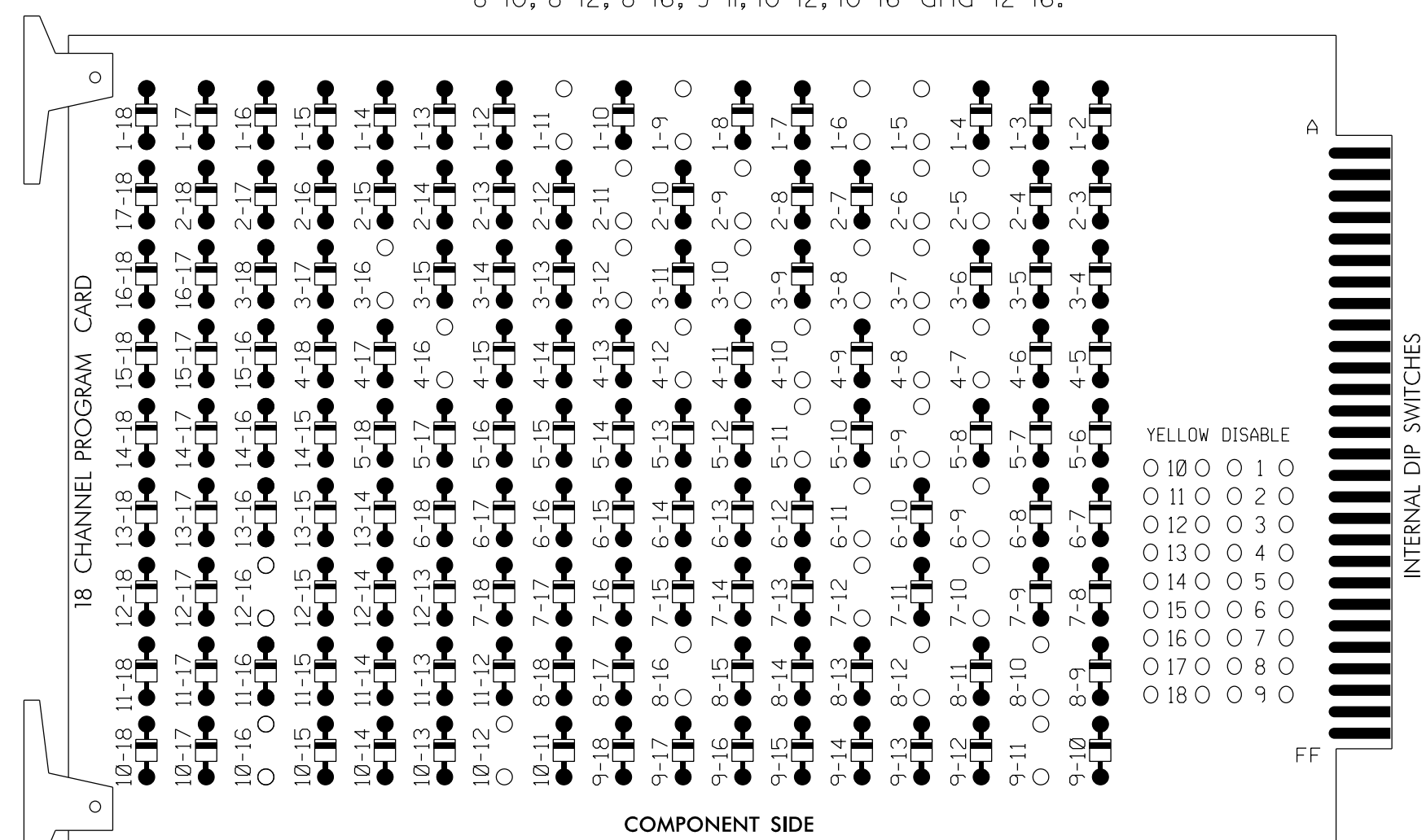

REMOVE JUMPERS AS SHOWN

NOTES:

- Card is provided with all diode jumpers in place. Removal of any jumper allows its channels to run concurrently.
- Ensure jumpers SEL2-SEL5 and SEL9 are present on the monitor board.
- Ensure that Red Enable is active at all times during normal operation.
- Integrate monitor with Ethernet network in cabinet.

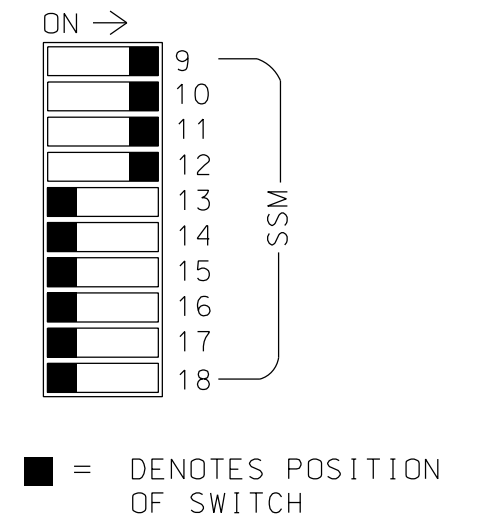
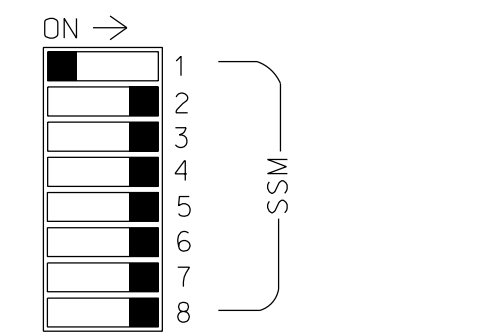
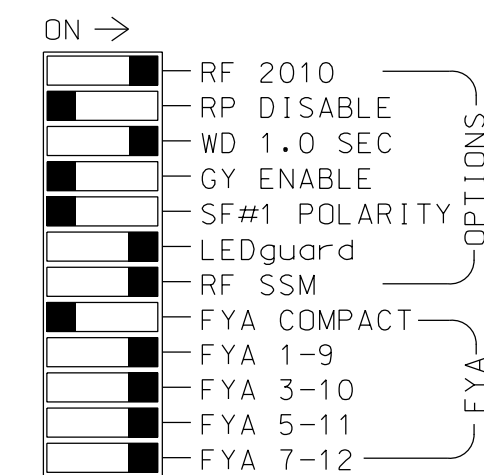

■ = DENOTES POSITION OF SWITCH

NOTES

- To prevent "flash-conflict" problems, insert red flash program blocks for all unused vehicle load switches in the output file. The installer shall verify that signal heads flash in accordance with the Signal Plans.
- Program phases 4 and 8 for Dual Entry.
- Program controller to start up in phase 2 Green and 6 Green.
- The cabinet and controller are part of the Burlington-Graham Signal System.

EQUIPMENT INFORMATION

CONTROLLER.....2070LX
 CABINET.....332 W/AUX
 SOFTWARE.....ECONOLITE ASC/3-2070
 CABINET MOUNT.....BASE
 OUTPUT FILE POSITIONS...18 WITH AUX. OUTPUT FILE
 LOAD SWITCHES USED.....S1,S2,S4,S5,S7,S8,S10,S11,S12
 AUX S1,AUX S2,AUX S4,AUX S5
 PHASES USED.....1,2,3,4,5,6,7,8,8PED
 OVERLAP "A".....*
 OVERLAP "B".....*
 OVERLAP "C".....*
 OVERLAP "D".....*
 * See overlap programming detail on sheet 2

COUNTDOWN PEDESTRIAN SIGNAL OPERATION

Countdown Ped Signals are required to display timing only during Ped Clearance Interval. Consult Ped Signal Module user's manual for instructions on selecting this feature.

INPUT FILE CONNECTION & PROGRAMMING CHART

LOOP NO.	LOOP TERMINAL	INPUT FILE POS.	PIN NO.	DETECTOR NO.	NEMA PHASE	CALL	EXTEND TIME	DELAY TIME	ADDED INITIAL	DETECTOR TYPE
1A ¹	TB2-1,2	I1U	56	1	1	YES		15		S
	-	J4U	48	26	6	YES		3		G
2A	TB2-5,6	I2U	39	2	2	YES			X	N
	-	J8U	50	28	8	YES		15		S
3A ²	TB4-5,6	I5U	58	3	3	YES				S
	-	J8U	50	28	8	YES				S
4A,4B	TB4-9,10	I6U	41	4	4	YES	3,1			S
	-	J8U	50	28	8	YES				S
4C	TB4-11,12	I6L	45	14	4	YES				S
	-	J8U	50	28	8	YES				S
4D	TB6-1,2	I7U	65	34	4	YES				S
	-	J8U	50	28	8	YES				S
*S1	TB6-9,10	I9U	60	11	SYS	NO				N
	-	J8U	50	28	8	YES				S
5A ³	TB3-1,2	J1U	55	5	5	YES		15		S
	-	I4U	47	22	2	YES		3		G
5B	TB3-5,6	J2U	40	6	5	YES		15		S
	-	J8U	50	28	8	YES				S
6A	TB3-9,10	J3U	64	36	6	YES			X	N
	-	J8U	50	28	8	YES				S
7A ⁴	TB5-5,6	J5U	57	7	7	YES		15		S
	-	I8U	49	24	4	YES				S
8A,8B	TB5-9,10	J6U	42	8	8	YES	3,1			S
	-	J8U	50	28	8	YES				S
8C	TB5-11,12	J6L	46	18	8	YES				S
	-	J8U	50	28	8	YES				S
8D	TB7-1,2	J7U	66	38	8	YES		10		S
	-	J8U	50	28	8	YES				S
PED PUSH BUTTONS										
P81,P82	TB8-8,9	I13L	70	70	PED 8	8 PED				

NOTE:
 INSTALL DC ISOLATOR IN INPUT FILE SLOT I13.

* System detector only. Remove any assigned vehicle phase.

- Add jumper from I1-W to J4-W, on rear of input file.
- Add jumper from I5-W to J8-W, on rear of input file.
- Add jumper from J1-W to I4-W, on rear of input file.
- Add jumper from J5-W to I8-W, on rear of input file.

INPUT FILE POSITION LEGEND: J2L

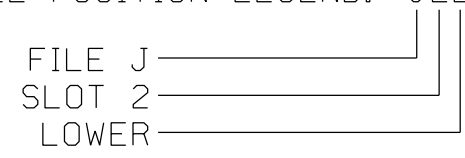

ATKINS 1616 EAST MILLBROOK ROAD, SUITE 160
 RALEIGH, NORTH CAROLINA 27609
 (919) 876-6888 NCBEES #F-0326

SIGNAL HEAD HOOK-UP CHART

LOAD SWITCH NO.	S1	S2	S3	S4	S5	S6	S7	S8	S9	S10	S11	S12	AUX S1	AUX S2	AUX S3	AUX S4	AUX S5	AUX S6	
CMU CHANNEL NO.	1	2	13	3	4	14	5	6	15	7	8	16	9	10	17	11	12	18	
PHASE	1	2	2 PED	3	4	4 PED	5	6	6 PED	7	8	8 PED	OLA	OLB	SPARE	OLC	OLD	SPARE	
SIGNAL HEAD NO.	11	21,22	NU	22	31	41,42	NU	42	51	61,62	NU	62	71	81,82	P81, P82	11	31	51	71
RED		128			*	101			*	134			*	107					
YELLOW	*	129				102				135				108					
GREEN		130				103				136				109					
RED ARROW																A121	A124	A114	A101
YELLOW ARROW						117				132			123			A122	A125	A115	A102
FLASHING YELLOW ARROW																A123	A126	A116	A103
GREEN ARROW	127					118	118			133	133		124	124					
Hand icon																			110
Walking person icon																			112

NU = Not Used

* Denotes install load resistor. See load resistor installation detail this sheet.

★ See pictorial of head wiring in detail this sheet.

FYA SIGNAL WIRING DETAIL

(wire signal heads as shown)

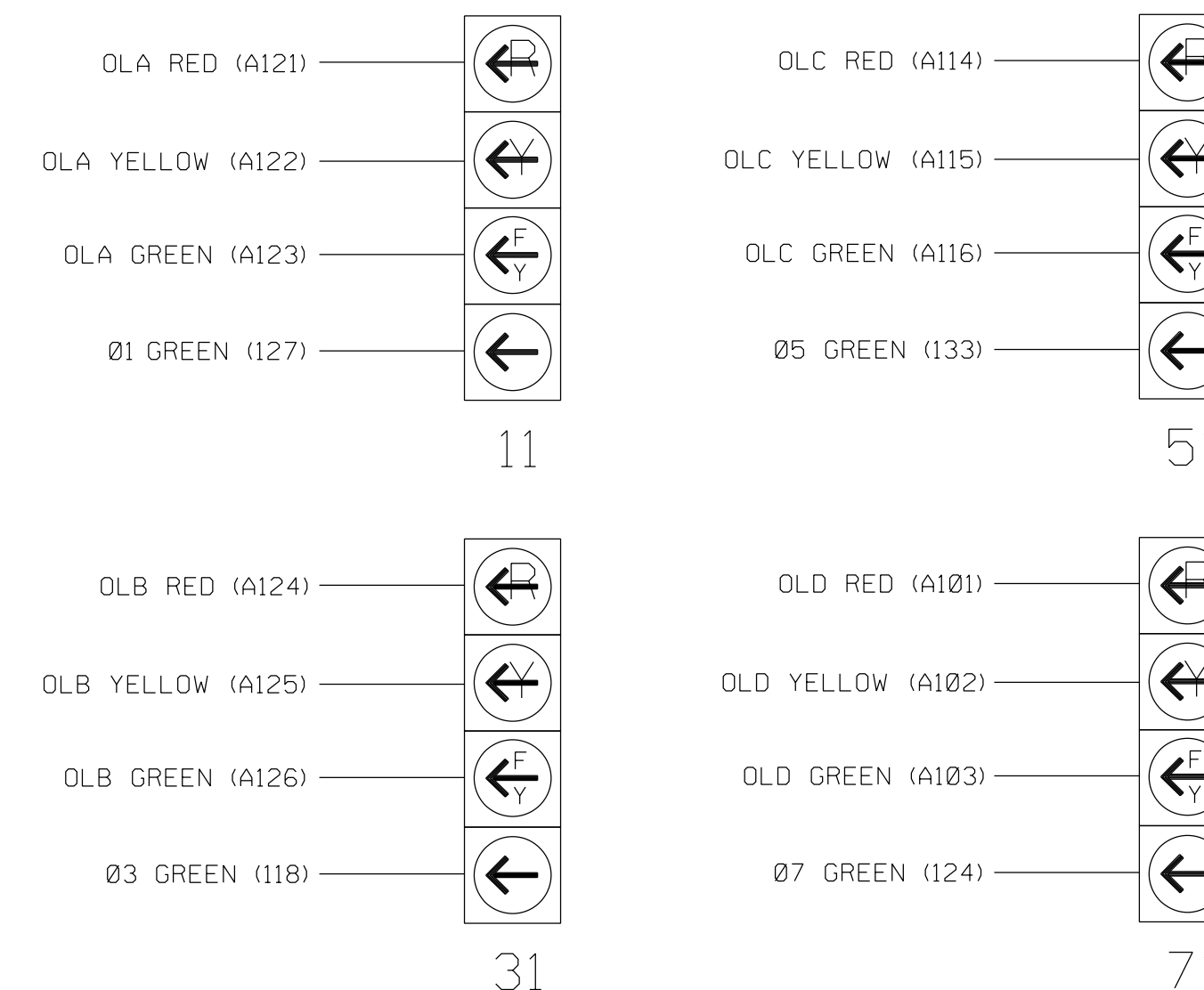

THIS ELECTRICAL DETAIL IS FOR THE SIGNAL DESIGN: 07-1996
 DESIGNED: January 2018
 SEALED: 6/7/2018
 REVISED: N/A

Electrical Detail - Sheet 1 of 2

ELECTRICAL AND PROGRAMMING DETAILS FOR: Prepared for the Offices of: 	US 70 (S. Church Street) at SR 1311 (University Drive)		SEAL NORTH CAROLINA PROFESSIONAL ENGINEER PAMELA L. ALEXANDER 023489 DATE: 6/9/2018
	Division 7 PLAN DATE: January 2018 PREPARED BY: AM Encarnacion	Alamance County REVIEWED BY: PL Alexander REVIEWED BY:	
REVISIONS:			SIG. INVENTORY NO. 07-1996

ECONOLITE ASC/3-2070 OVERLAP PROGRAMMING DETAIL

(program controller as shown)

1. From Main Menu select 2. CONTROLLER
2. From CONTROLLER Submenu select 2. VEHICLE OVERLAPS

OVERLAP A

Select TMG VEH OVLP [A] and 'PPLT FYA'

TMG VEH OVLP... [A] TYPE:PPLT FYA

PROTECTED LEFT TURN.... PHASE 1

OPPOSING THROUGH..... PHASE 2

FLASHING ARROW OUTPUT.....CH9 ISOLATE

DELAY START OF: FYA..0.0 CLEARANCE..0.0

ACTION PLAN SF BIT DISABLE..... 0

Toggle Once

OVERLAP B

Select TMG VEH OVLP [B] and 'PPLT FYA'

TMG VEH OVLP... [B] TYPE:PPLT FYA

PROTECTED LEFT TURN.... PHASE 3

OPPOSING THROUGH..... PHASE 4

FLASHING ARROW OUTPUT.....CH10 ISOLATE

DELAY START OF: FYA..0.0 CLEARANCE..0.0

ACTION PLAN SF BIT DISABLE..... 0

Toggle Once

OVERLAP C

Select TMG VEH OVLP [C] and 'PPLT FYA'

TMG VEH OVLP... [C] TYPE:PPLT FYA

PROTECTED LEFT TURN.... PHASE 5

OPPOSING THROUGH..... PHASE 6

FLASHING ARROW OUTPUT.....CH11 ISOLATE

DELAY START OF: FYA..0.0 CLEARANCE..0.0

ACTION PLAN SF BIT DISABLE..... 0

Toggle Once

OVERLAP D

Select TMG VEH OVLP [D] and 'PPLT FYA'

TMG VEH OVLP... [D] TYPE:PPLT FYA

PROTECTED LEFT TURN.... PHASE 7

OPPOSING THROUGH..... PHASE 8

FLASHING ARROW OUTPUT.....CH12 ISOLATE

DELAY START OF: FYA..0.0 CLEARANCE..0.0

ACTION PLAN SF BIT DISABLE..... 0

END PROGRAMMING

FLASHER CIRCUIT MODIFICATION DETAIL

IN ORDER TO ENSURE THAT SIGNALS FLASH CONCURRENTLY ON THE SAME APPROACH, MAKE THE FOLLOWING FLASHER CIRCUIT CHANGES:

1. ON REAR OF PDA - REMOVE WIRE FROM TERM. T2-4 AND TERMINATE ON T2-2.
2. ON REAR OF PDA - REMOVE WIRE FROM TERM. T2-5 AND TERMINATE ON T2-3.
3. REMOVE FLASHER UNIT 2.

THE CHANGES LISTED ABOVE TIES ALL PHASES AND OVERLAPS TO FLASHER UNIT 1.

THIS ELECTRICAL DETAIL IS FOR THE SIGNAL DESIGN: 07-1996
 DESIGNED: January 2018
 SEALED: 6/7/2018
 REVISED: N/A

Electrical Detail - Sheet 2 of 2

DOCUMENT NOT CONSIDERED FINAL UNLESS ALL SIGNATURES COMPLETED

ELECTRICAL AND PROGRAMMING DETAILS FOR:

Prepared for the Offices of:

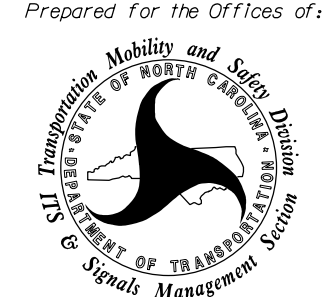

750 N. Greenfield Pkwy, Garner, NC 27529

US 70 (S. Church Street) at SR 1311 (University Drive)	
Division 7	Alamance County Burlington
PLAN DATE: January 2018	REVIEWED BY: PL Alexander
PREPARED BY: AM Encarnacion	REVIEWED BY:
REVISIONS	INIT. DATE

SEAL

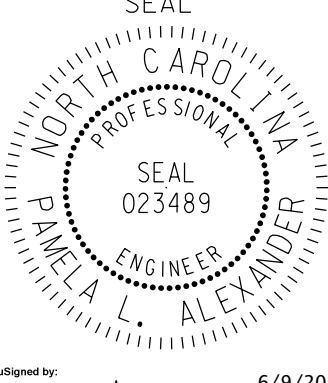

SEAL 023489

PAMELA L. ALEXANDER

ENGINEER

6/9/2018

DATE

SIGNED BY: Pamela Alexander

DATE

SIG. INVENTORY NO. 07-1996

09-JUN-2018 14:15
 D:\Consolidated\Traf\Office\Kurr\100056469 U-6015 B-G Sig System\Task 05_11_Signal\Des\gym\Tr-Ing\07-1996E.dgn
 ALEX3361 AT LUS330669

PHASING DIAGRAM

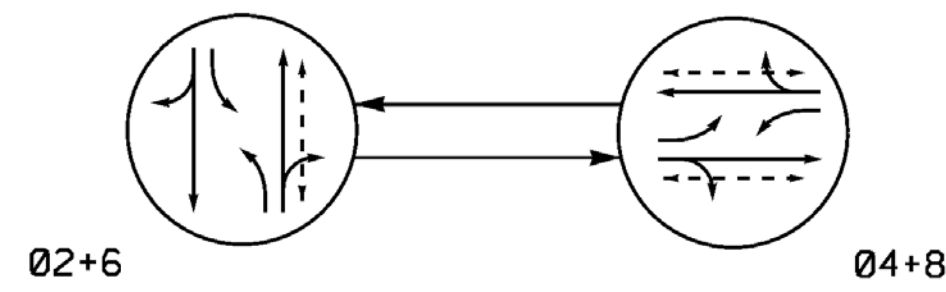

PHASING DIAGRAM DETECTION LEGEND

- ←● DETECTED MOVEMENT
- ← UNDETECTED MOVEMENT (OVERLAP)
- ←- - UNSIGNALIZED MOVEMENT
- ←- - - PEDESTRIAN MOVEMENT

TABLE OF OPERATION

SIGNAL FACE	PHASE		
	02+6	04+8	FLASH
21, 22	G	R	Y
41, 42	R	G	R
61, 62	G	R	Y
81, 82	R	G	R
P21, P22	W	DW	DRK
P41, P42	DW	W	DRK
P81, P82	DW	W	DRK

2 Phase
Pre-Timed
(Burlington-Graham Signal System)

NOTES

1. Refer to "Roadway Standard Drawings NCDOT" dated January 2018 and "Standard Specifications for Roads and Structures" dated January 2018.
2. Do not program signal for late night flashing operation unless otherwise directed by the Engineer.
3. Locate new cabinet so as not to obstruct sight distance of vehicles turning right on red.
4. Program pedestrian heads to countdown the flashing "Don't Walk" time only.
5. Pavement markings are existing.
6. Maximum times shown in timing chart are for free-run operation only. Coordinated signal system timing values supersede these values.
7. Provide minimum of 15' clearance from high point in roadway to bottom of proposed signal heads.

SIGNAL FACE I.D.

All Heads L.E.D.

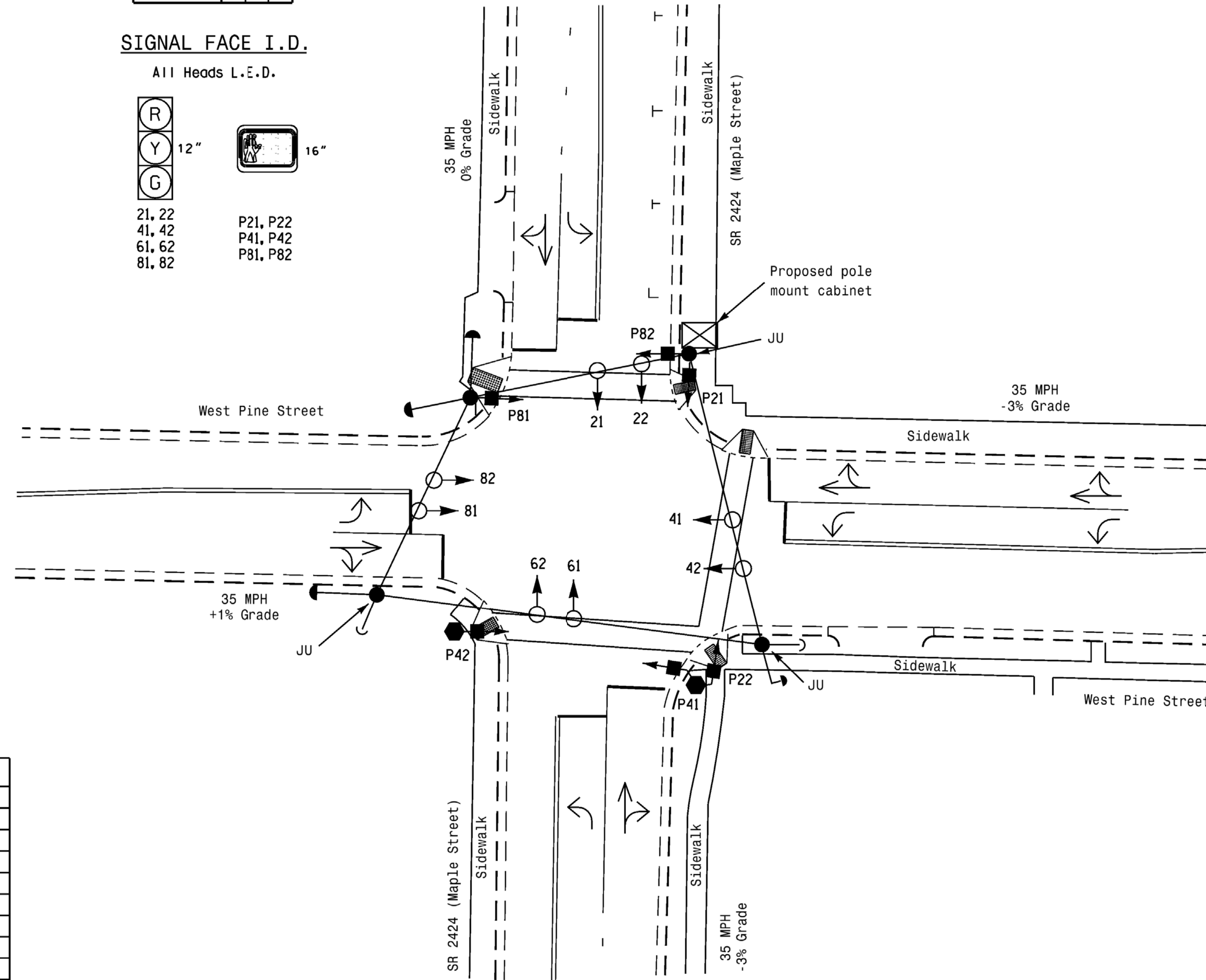
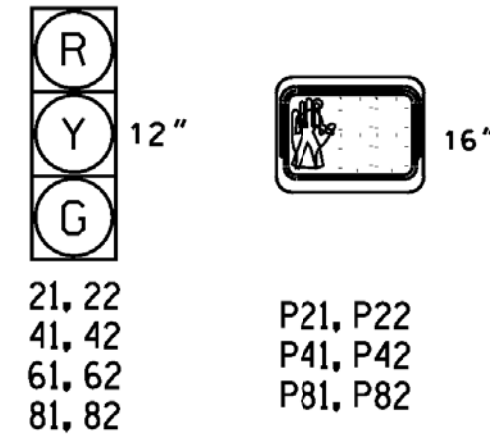

ASC/3 TIMING CHART

FEATURE	PHASE			
	2	4	6	8
Min Green *	10	7	10	7
Walk *	4	4	0	4
Ped Clear	11	12	0	9
Veh. Extension *	0.0	0.0	0.0	0.0
Max I *	43	25	43	25
Yellow	4.1	3.8	3.8	4.1
Red Clear	1.5	1.4	1.6	1.3
Actuations B4 Add *	-	-	-	-
Seconds / Actuation *	-	-	-	-
Max Initial *	-	-	-	-
Time Before Reduction *	-	-	-	-
Time To Reduce *	-	-	-	-
Minimum Gap	-	-	-	-
Locking Detector	-	-	-	-
Recall Position	MAX/PED	MAX/PED	MAX	MAX/PED
Dual Entry	-	-	-	-
Simultaneous Gap	X	X	X	X

* These values may be field adjusted. Do not adjust Min Green and Extension times for phases 2 and 6 lower than what is shown. Min Green for all other phases should not be lower than 4 seconds.

PROPOSED	EXISTING
○→ Traffic Signal Head	●→ N/A
●→ Modified Signal Head	— Sign
⊥ Pedestrian Signal Head	⊥ With Sign
⊥ Signal Pole with Guy	⊥ Signal Pole with Sidewalk Guy
⊥ Inductive Loop Detector	⊥ Controller & Cabinet
⊥ Junction Box	⊥ Junction Box
⊥ 2-in Underground Conduit	⊥ Right of Way
→ Directional Arrow	→ Directional Arrow
○ Type II Signal Pedestal	● Wheelchair Ramp

Mattern & Craig
ENGINEERS • SURVEYORS

12 BROAD STREET
ASHEVILLE, NORTH CAROLINA 28801
(828) 254-2201
FAX (828) 254-4562
NC LIC. NO. C-1154

Signal Upgrade

Prepared for the Offices of:
TRANSPORTATION MOBILITY AND SAFETY DIVISION
DEPARTMENT OF TRANSPORTATION
Signal Design Section
750 N. Greenfield Pkwy, Garner, NC 27529
SCALE 1"=20'

DOCUMENT NOT CONSIDERED FINAL UNLESS ALL SIGNATURES COMPLETED

SR 2424 (Maple Street) at West Pine Street

Division 7 Alamance County Graham

PLAN DATE: September 2017 REVIEWED BY: JB Voso

PREPARED BY: SE Wilson REVIEWED BY:

REVISIONS

INIT. DATE

SEAL
NORTH CAROLINA PROFESSIONAL ENGINEER
JAMES B. VOSO
6/13/2018
SIG. INVENTORY NO. 07-2063

EDI MODEL 2018EClip-NC CONFLICT MONITOR PROGRAMMING DETAIL

(remove jumpers and set switches as shown)

REMOVE DIODE JUMPERS 2-6, 2-13, 4-8, 4-14, 4-16, 6-13, 8-14, 8-16, and 14-16.



REMOVE JUMPERS AS SHOWN

NOTES:

1. Card is provided with all diode jumpers in place. Removal of any jumper allows its channels to run concurrently.
2. Ensure jumpers SEL2-SEL5 and SEL9 are present on the monitor board.
3. Ensure that Red Enable is active at all times during normal operation.
4. Integrate monitor with Ethernet network in cabinet.

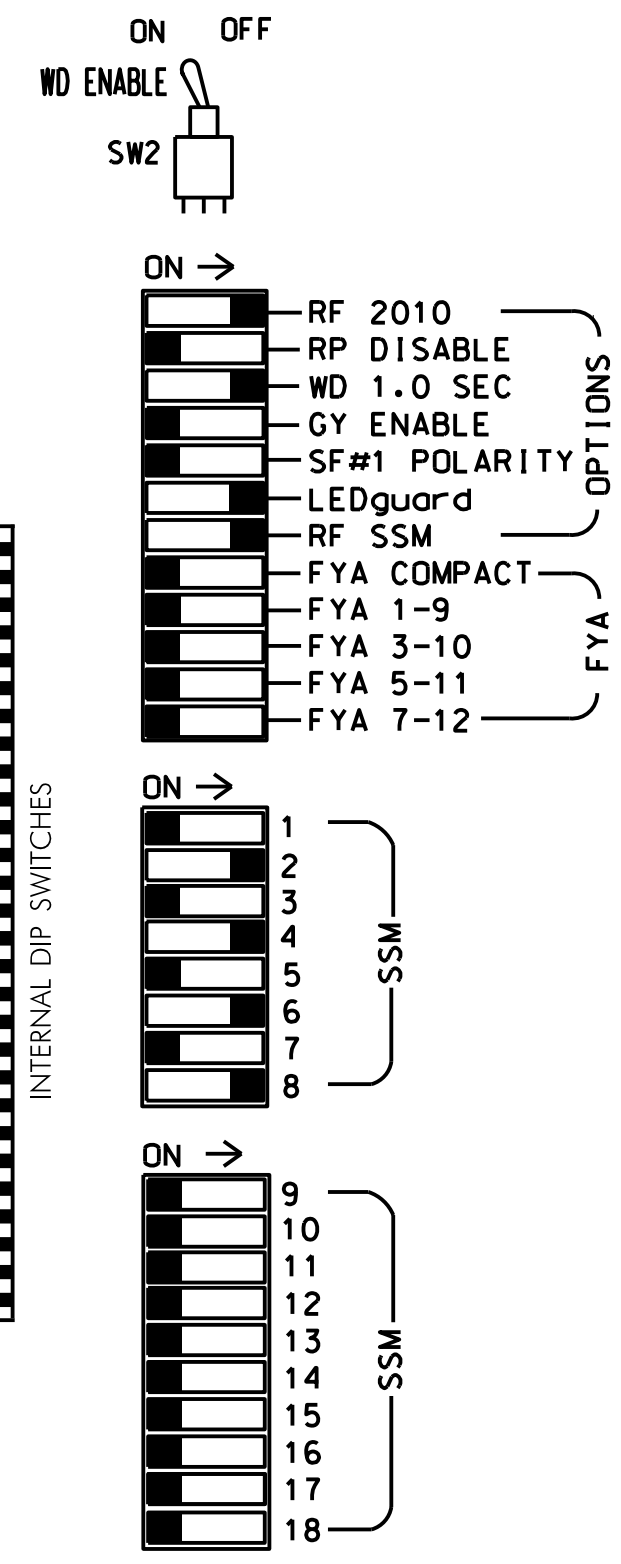

■ = DENOTES POSITION OF SWITCH

NOTES

1. To prevent "flash-conflict" problems, insert red flash program blocks for all unused vehicle load switches in the output file. The installer shall verify that signal heads flash in accordance with the Signal Plans.
2. Program controller to start up in phase 2 Walk and 6 Green.
3. The cabinet and controller are part of the Burlington-Graham Signal System.

EQUIPMENT INFORMATION

CONTROLLER.....2070LX
 CABINET.....336
 SOFTWARE.....ECONOLITE ASC/3-2070
 CABINET MOUNT.....POLE
 OUTPUT FILE POSITIONS...12
 LOAD SWITCHES USED.....S2,S3,S5,S6,S8,S11,S12
 PHASES USED.....2,2PED,4,4PED,6,8,8PED
 OVERLAPS.....NONE

SIGNAL HEAD HOOK-UP CHART

LOAD SWITCH NO.	S1	S2	S3	S4	S5	S6	S7	S8	S9	S10	S11	S12
CMU CHANNEL NO.	1	2	13	3	4	14	5	6	15	7	8	16
PHASE	1	2	2 PED	3	4	4 PED	5	6	6 PED	7	8	8 PED
SIGNAL HEAD NO.	NU	21,22	P21, P22	NU	41,42	P41, P42	NU	61,62	NU	NU	81,82	P81, P82
RED		128			101			134			107	
YELLOW		129			102			135			108	
GREEN		130			103			136			109	
RED ARROW												
YELLOW ARROW												
GREEN ARROW												
Hand icon			113			104						110
Walking person icon			115			106						112

NU = Not Used

COUNTDOWN PEDESTRIAN SIGNAL OPERATION

Countdown Ped Signals are required to display timing only during Ped Clearance Interval. Consult Ped Signal Module user's manual for instructions on selecting this feature.

INPUT FILE POSITION LAYOUT

(front view)

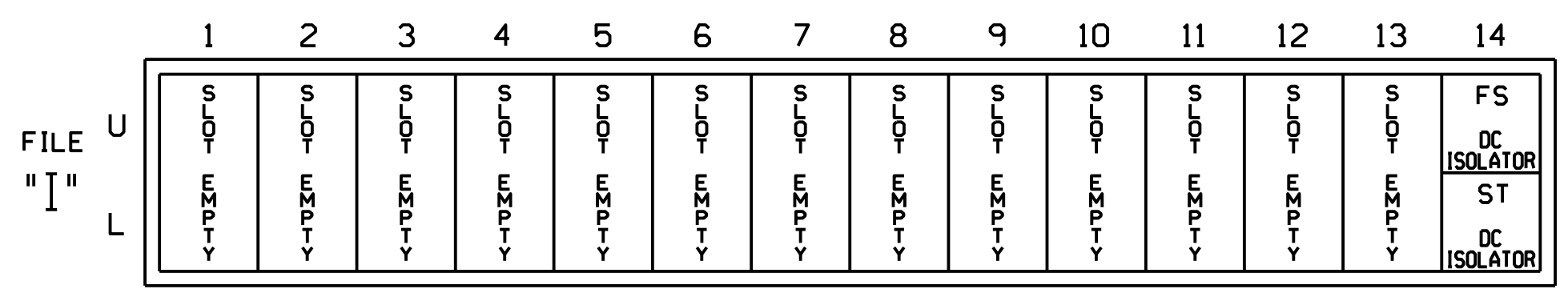

EX.: 1A, 2A, ETC. = LOOP NO.'S

FS = FLASH SENSE
 ST = STOP TIME

THIS ELECTRICAL DETAIL IS FOR THE SIGNAL DESIGN: 07-2063
 DESIGNED: September 2017
 SEALED: 6/13/2018
 REVISED: NA

*****SYTIME*****
 *****DOCS*****
 *****USER*****



12 BROAD STREET
 ASHEVILLE, NORTH CAROLINA 28801
 (828) 254-2201
 FAX (828) 254-4562
 NC LIC. NO. C-1154

Electrical Detail

DOCUMENT NOT CONSIDERED FINAL UNLESS ALL SIGNATURES COMPLETED

Prepared for the Offices of:
 City of Asheville, North Carolina
 Department of Public Works
 Signal Management Section

SR 2424 (Maple Street) at West Pine Street

Division 7 Alamance County Graham

PLAN DATE: September 2017 REVIEWED BY: JB Voso
 PREPARED BY: SE Wilson REVIEWED BY:

REVISIONS INIT. DATE

James Voso 6/13/2018

Seal: NORTH CAROLINA PROFESSIONAL ENGINEER SEAL 022599 JAMES B. VOSO

SIG. INVENTORY NO. 07-2063

PHASING DIAGRAM

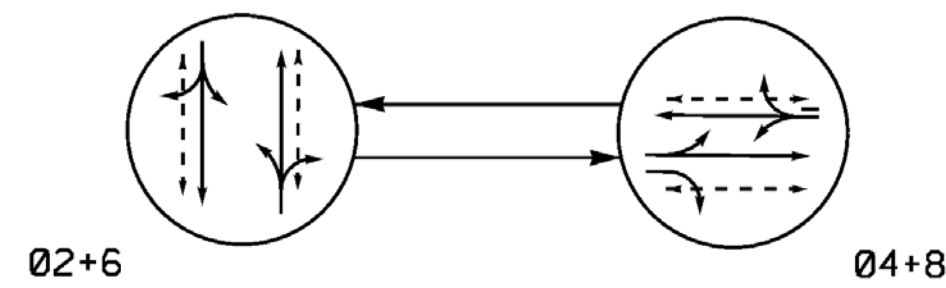

PHASING DIAGRAM DETECTION LEGEND

- ←● DETECTED MOVEMENT
- ← UNDETECTED MOVEMENT (OVERLAP)
- ←- - UNSIGNALIZED MOVEMENT
- ←- - - PEDESTRIAN MOVEMENT

TABLE OF OPERATION

SIGNAL FACE	PHASE		
	02+6	04+8	FLASH
2L, 22	G	R	Y
4L, 42	R	G	R
6L, 62	G	R	Y
8L, 82	R	G	R
P2L, P22	W	DW	DRK
P4L, P42	DW	W	DRK
P6L, P62	W	DW	DRK
P8L, P82	DW	W	DRK

SIGNAL FACE I.D.

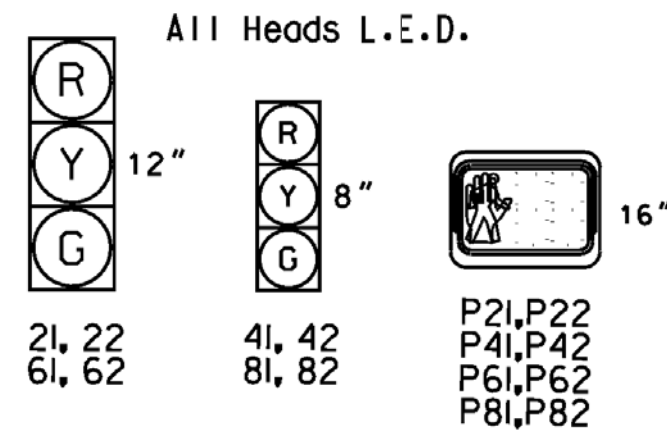

2 Phase
Pre-Timed
(Burlington-Graham Signal System)

NOTES

- Refer to "Roadway Standard Drawings NCDOT" dated January 2018 and "Standard Specifications for Roads and Structures" dated January 2018.
- Do not program signal for late night flashing operation unless otherwise directed by the Engineer.
- Locate new cabinet so as not to obstruct sight distance of vehicles turning right on red.
- Program pedestrian heads to countdown the flashing "Don't Walk" time only.
- Pavement markings are existing.
- Maximum times shown in timing chart are for free-run operation only. Coordinated signal system timing values supersede these values.

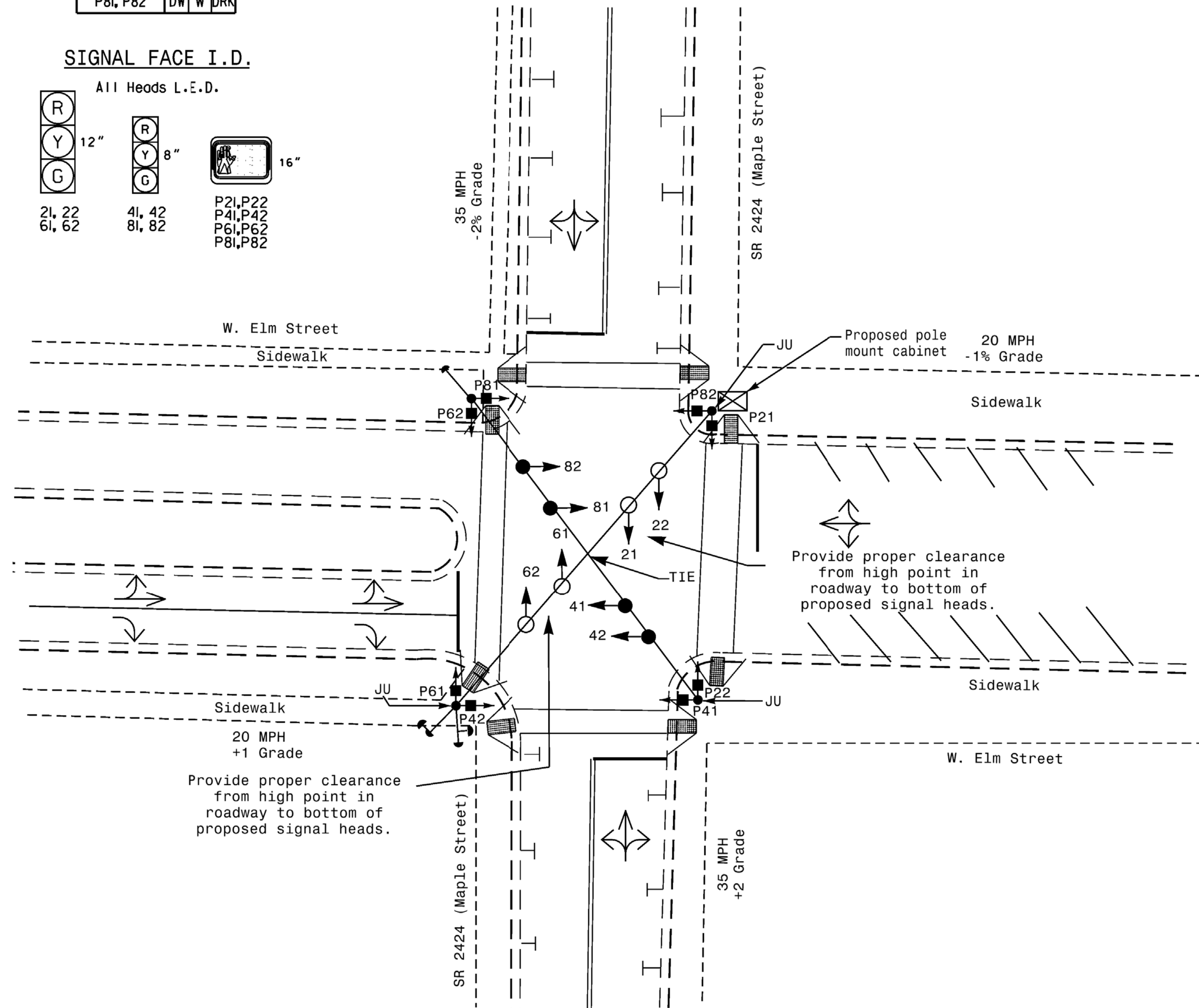

ASC/3 TIMING CHART

FEATURE	PHASE			
	2	4	6	8
Min Green *	10	7	10	7
Walk *	4	4	4	4
Ped Clear	13	9	15	9
Veh. Extension *	0.0	0.0	0.0	0.0
Max I *	31	37	31	37
Yellow	3.7	3.0	4.0	3.0
Red Clear	1.9	2.4	1.9	2.6
Actuations B4 Add *	-	-	-	-
Seconds /Actuation *	-	-	-	-
Max Initial *	-	-	-	-
Time Before Reduction *	-	-	-	-
Time To Reduce *	-	-	-	-
Minimum Gap	-	-	-	-
Locking Detector	-	-	-	-
Recall Position	MAX/PED	MAX/PED	MAX/PED	MAX/PED
Dual Entry	-	-	-	-
Simultaneous Gap	X	X	X	X

* These values may be field adjusted. Do not adjust Min Green and Extension times for phases 2 and 6 lower than what is shown. Min Green for all other phases should not be lower than 4 seconds.

LEGEND	
PROPOSED	EXISTING
○ → Traffic Signal Head	● → N/A
● → Modified Signal Head	— Sign
⊥ Pedestrian Signal Head	⊥
○ ⊥ Signal Pole with Guy	⊥ ⊥ Signal Pole with Sidewalk Guy
⊥ Inductive Loop Detector	⊥ ⊥
⊠ Controller & Cabinet	⊠ Junction Box
⊠ 2-in Underground Conduit	⊠
N/A Right of Way	⊠
→ Directional Arrow	→
↯ Wheelchair Ramp	↯

Mattern & Craig
ENGINEERS • SURVEYORS

12 BROAD STREET
ASHEVILLE, NORTH CAROLINA 28801
(828) 254-2201
FAX (828) 254-4562
NC LIC. NO. C-1154

Signal Upgrade

DOCUMENT NOT CONSIDERED FINAL UNLESS ALL SIGNATURES COMPLETED

SR 2424 (Maple Street)
at
W. Elm Street

Division 7 Alamance County Graham

PLAN DATE: September 2017 REVIEWED BY: JB Voso

PREPARED BY: SE Wilson REVIEWED BY:

REVISIONS	INIT.	DATE

SIGNATURE: James B. Vosso DATE: 6/13/2018

SIG. INVENTORY NO. 07-2064

EDI MODEL 2018EClip-NC CONFLICT MONITOR PROGRAMMING DETAIL

(remove jumpers and set switches as shown)

REMOVE DIODE JUMPERS 2-6, 2-13, 2-15, 4-8, 4-14, 4-16, 6-13, 6-15, 8-14, 8-16, 13-15, and 14-16.



REMOVE JUMPERS AS SHOWN

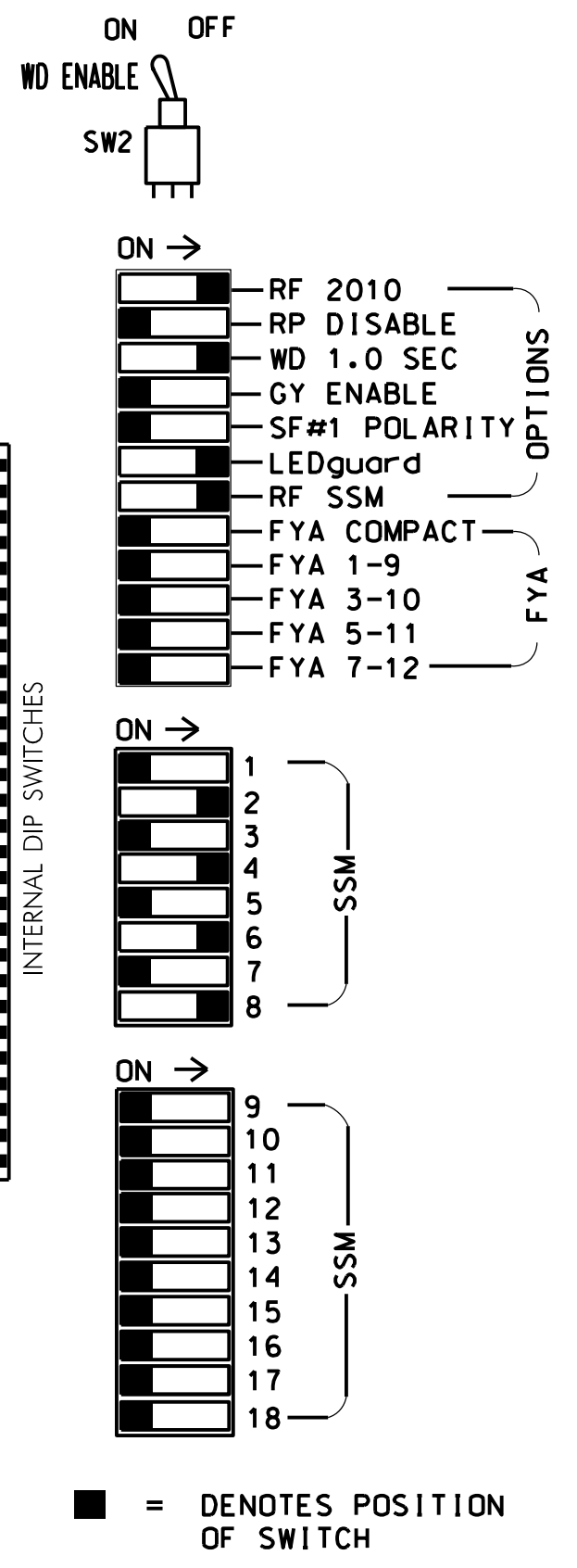

NOTES:

- Card is provided with all diode jumpers in place. Removal of any jumper allows its channels to run concurrently.
- Ensure jumpers SEL2-SEL5 and SEL9 are present on the monitor board.
- Ensure that Red Enable is active at all times during normal operation.
- Integrate monitor with Ethernet network in cabinet.

NOTES

- To prevent "flash-conflict" problems, insert red flash program blocks for all unused vehicle load switches in the output file. The installer shall verify that signal heads flash in accordance with the Signal Plans.
- Program controller to start up in phase 2 Walk and 6 Walk.
- The cabinet and controller are part of the Burlington-Graham Signal System.

SIGNAL HEAD HOOK-UP CHART

LOAD SWITCH NO.	S1	S2	S3	S4	S5	S6	S7	S8	S9	S10	S11	S12
CMU CHANNEL NO.	1	2	13	3	4	14	5	6	15	7	8	16
PHASE	1	2	2 PED	3	4	4 PED	5	6	6 PED	7	8	8 PED
SIGNAL HEAD NO.	NU	21,22	P21, P22	NU	41,42	P41, P42	NU	61,62	P61, P62	NU	81,82	P81, P82
RED		128			101			134				107
YELLOW		129			102			135				108
GREEN		130			103			136				109
RED ARROW												
YELLOW ARROW												
GREEN ARROW												
Hand			113			104			119			110
Walker			115			106			121			112

NU = Not Used

EQUIPMENT INFORMATION

CONTROLLER.....2070LX
 CABINET.....336
 SOFTWARE.....ECONOLITE ASC/3-2070
 CABINET MOUNT.....POLE
 OUTPUT FILE POSITIONS...12
 LOAD SWITCHES USED.....S2,S3,S5,S6,S8,S9,S11,S12
 PHASES USED.....2,2PED,4,4PED,6,6PED,8,8PED
 OVERLAPS.....NONE

COUNTDOWN PEDESTRIAN SIGNAL OPERATION

Countdown Ped Signals are required to display timing only during Ped Clearance Interval. Consult Ped Signal Module user's manual for instructions on selecting this feature.

INPUT FILE POSITION LAYOUT

(front view)

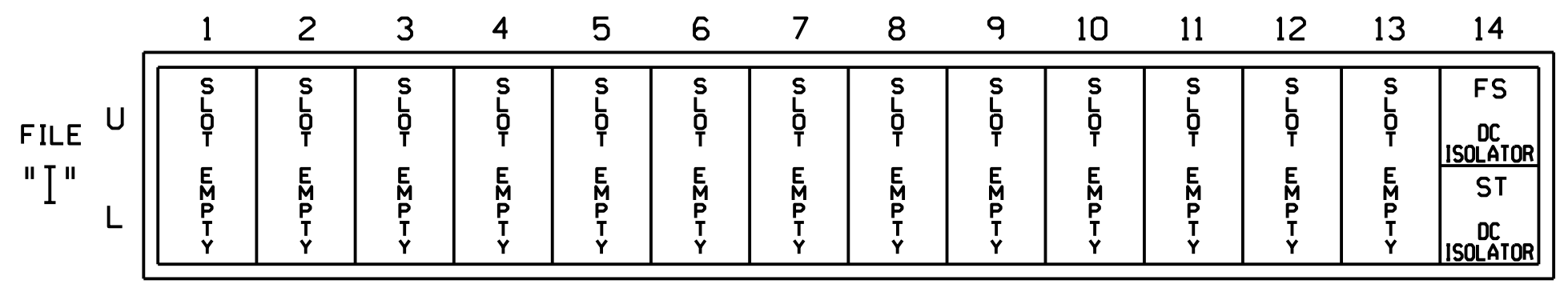

EX.: 1A, 2A, ETC. = LOOP NO.'S

FS = FLASH SENSE
 ST = STOP TIME

THIS ELECTRICAL DETAIL IS FOR THE SIGNAL DESIGN: 07-2064
 DESIGNED: September 2017
 SEALED: 6/13/2018
 REVISED: NA

Vertical text on the left edge of the page.



12 BROAD STREET
 ASHEVILLE, NORTH CAROLINA 28801
 (828) 254-2201
 FAX (828) 254-4562
 NC LIC. NO. C-1154

Electrical Detail

ELECTRICAL AND PROGRAMMING DETAILS FOR:



SR 2424 (Maple Street) at W. Elm Street

Division 7 Alamance County Graham

PLAN DATE: September 2017 REVIEWED BY: JB Voso

PREPARED BY: SE Wilson REVIEWED BY:

REVISIONS	INIT.	DATE

DOCUMENT NOT CONSIDERED FINAL UNLESS ALL SIGNATURES COMPLETED

SEAL
 NORTH CAROLINA PROFESSIONAL ENGINEER
 JAMES B. VOSO
 SEAL 022599
 James Voso 6/13/2018
 SIGNATURE DATE
 SIG. INVENTORY NO. 07-2064

PHASING DIAGRAM

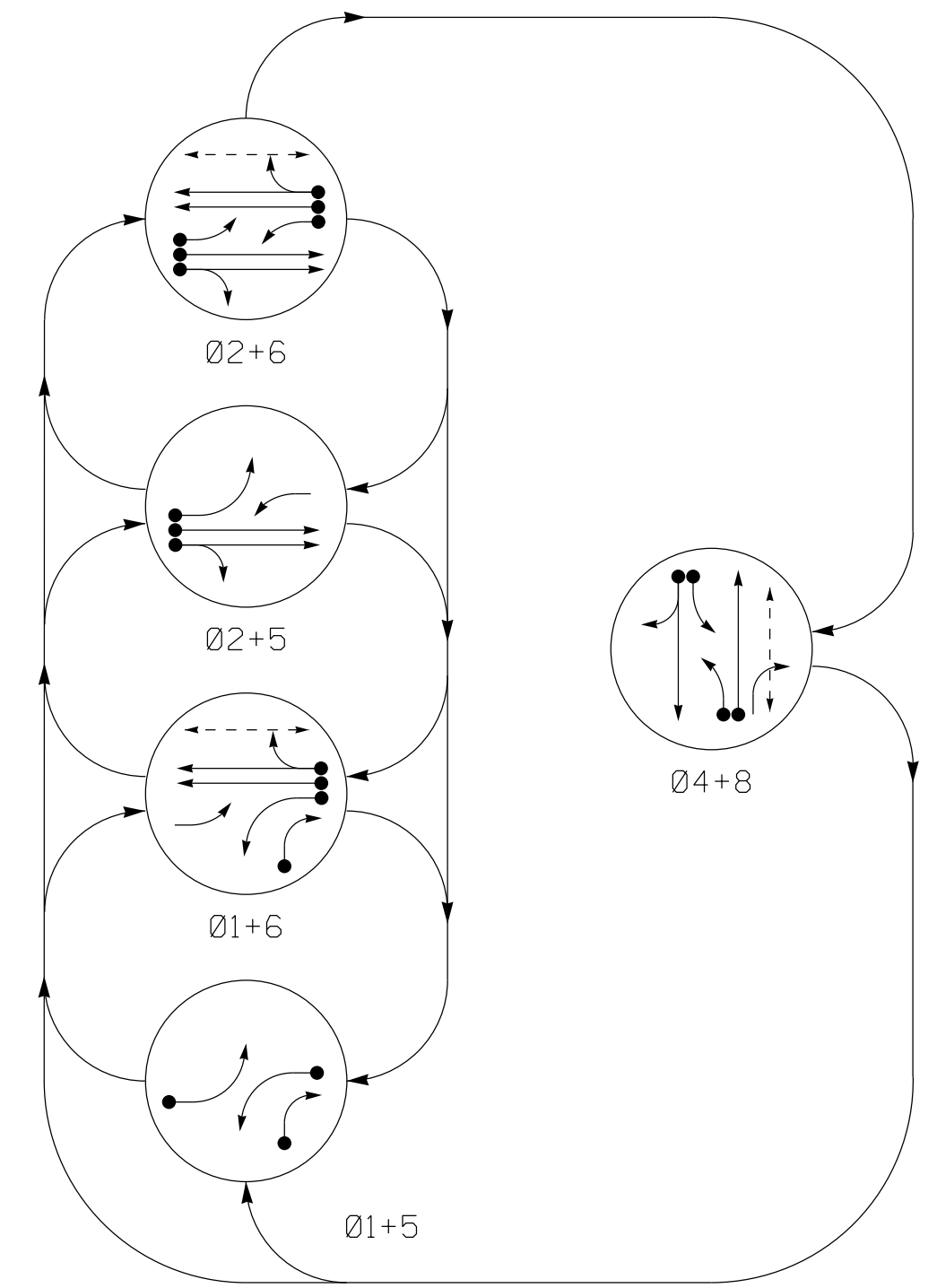

PHASING DIAGRAM DETECTION LEGEND

- DETECTED MOVEMENT
- ◄ UNDETECTED MOVEMENT (OVERLAP)
- ⋯ UNSIGNALIZED MOVEMENT
- ⋯ PEDESTRIAN MOVEMENT

TABLE OF OPERATION

SIGNAL FACE	PHASE					
	01+5	02+5	02+6	04+8	FLASH	H
11	←	←	←	←	←	←
21,22	R	R	G	G	R	Y
41,42,43	R	R	R	R	G	R
51	←	←	←	←	←	←
61,62	R	G	R	G	R	Y
81,83	R	R	R	R	G	R
82	R	R	R	R	G	R
P61,P62	DW	W	DW	W	DW	DRK
P81,P82	DW	DW	DW	DW	W	DRK

SIGNAL FACE I.D.

All Heads L.E.D.

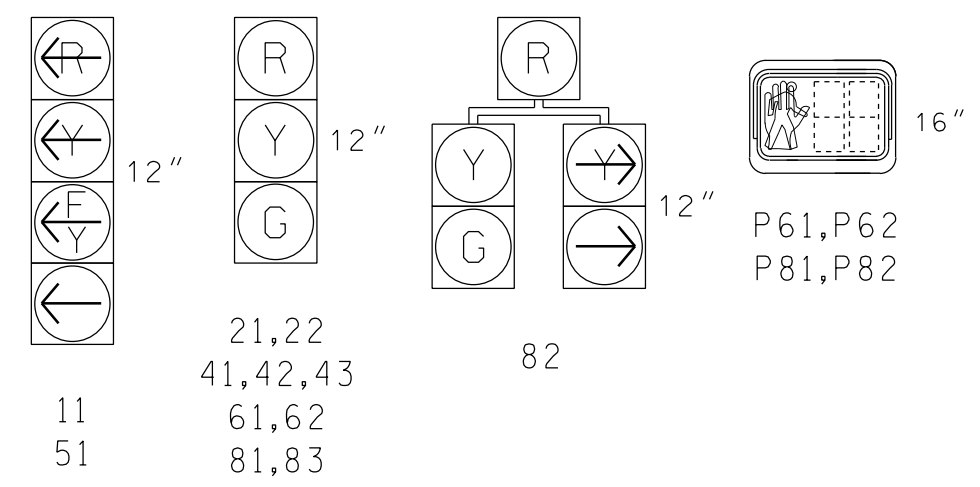

ASC/3 DETECTOR INSTALLATION CHART

LOOP	SIZE (FT)	DISTANCE FROM STOPBAR (FT)	TURNS	NEW LOOP	PROGRAMMING							
					PHASE	CALLING	EXTEND TIME	DELAY TIME	USE ADDED INITIAL	TYPE	SYSTEM LOOP	NEW CARD
1A	6X40	0	2-4-2	-	1	Yes	-	15	-	S	-	X
1B	6X40	0	2-4-2	-	6	Yes	-	3	-	G	-	X
1C	6X15	0	2-4-2	-	1	Yes	-	15	-	S	-	X
2A	6X6	300	EXIST	-	2	Yes	-	-	X	N	-	X
2B	6X6	300	EXIST	-	2	Yes	-	-	X	N	-	X
4A	6X40	+5	2-4-2	-	4	Yes	-	-	-	S	-	X
4B	6X40	+5	2-4-2	-	4	Yes	-	10	-	S	-	X
5A	6X60	+5	2-4-2	-	5	Yes	-	15	-	S	-	X
6A	6X6	300	EXIST	-	6	Yes	-	-	X	N	-	X
6B	6X6	300	EXIST	-	6	Yes	-	-	X	N	-	X
8A	6X40	+5	2-4-2	-	8	Yes	-	-	-	S	-	X
8B	6X40	+5	2-4-2	-	8	Yes	-	-	-	S	-	X
S1	6X6	+270	4	X	-	No	-	-	-	N	X	X
S2	6X6	+270	4	X	-	No	-	-	-	N	X	X

5 Phase Fully Actuated (Burlington-Graham Signal System)

NOTES

- Refer to "Roadway Standard Drawings NCDOT" dated January 2018 and "Standard Specifications for Roads and Structures" dated January 2018.
- Do not program signal for late night flashing operation unless otherwise directed by Engineer.
- Phase 1 and/or phase 5 may be lagged.
- Set all detector units to presence mode.
- In the event of loop replacement, refer to the current ITS and Signals Design Manual and submit a Plan of Record to the Signal Design Section.
- Locate new cabinet so as not to obstruct sight distance of vehicles turning right on red.
- Omit "WALK" and flashing "DON'T WALK" with no pedestrian calls.
- Program pedestrian heads to countdown the flashing "DON'T WALK" time only.
- Pavement markings are existing.
- Maximum times shown in timing chart are for free-run operation only. Coordinated signal system timing values supersede these values.

LEGEND

- | PROPOSED | EXISTING |
|--|----------|
| ○ → Traffic Signal Head | ● → N/A |
| ○ → Modified Signal Head | ○ → N/A |
| ○ → Pedestrian Signal Head | ○ → N/A |
| * Pedestrian Push Button & Sign | * → N/A |
| ⊕ Type I Pushbutton Post | ⊕ → N/A |
| ⊙ Type II Signal Pedestal | ⊙ → N/A |
| ○ Signal Pole with Guy | ○ → N/A |
| ○ Signal Pole with Sidewalk Guy | ○ → N/A |
| ○ Metal Pole with Mastarm | ○ → N/A |
| ⊠ Inductive Loop Detector | ⊠ → N/A |
| ⊠ Controller & Cabinet | ⊠ → N/A |
| ⊠ Junction Box | ⊠ → N/A |
| ⋯ 2-in Underground Conduit | ⋯ → N/A |
| N/A Right of Way | ⋯ → N/A |
| N/A Directional Arrow | → → N/A |
| N/A Curb Ramp | ▴ → N/A |
| ⊠ "U-TURN YIELD TO RIGHT TURN" Sign (R10-16) | ⊠ → N/A |

ASC/3 TIMING CHART

FEATURE	PHASE					
	1	2	4	5	6	8
Min Green *	7	12	7	7	12	7
Walk *	0	0	0	0	4	4
Ped Clear	0	0	0	0	24	24
Veh. Extension *	2.0	6.0	2.0	3.0	6.0	2.0
Max 1 *	25	90	20	15	90	20
Yellow	3.0	4.4	4.1	3.0	4.4	3.7
Red Clear	3.6	2.5	2.4	3.8	2.5	2.3
Activations B4 Add *	-	0	-	-	0	-
Seconds / Actuation *	-	1.5	-	-	1.5	-
Max Initial *	-	34	-	-	34	-
Time Before Reduction *	-	15	-	-	15	-
Time To Reduce *	-	30	-	-	30	-
Minimum Gap	-	3.0	-	-	3.0	-
Locking Detector	-	X	-	-	X	-
Recall Position	-	VEH. RECALL	-	-	VEH. RECALL	-
Dual Entry	-	-	X	-	-	X
Simultaneous Gap	X	X	X	X	X	X

* These values may be field adjusted. Do not adjust Min Green and Extension times for phases 2 and 6 lower than what is shown. Min Green for all other phases should not be lower than 4 seconds.

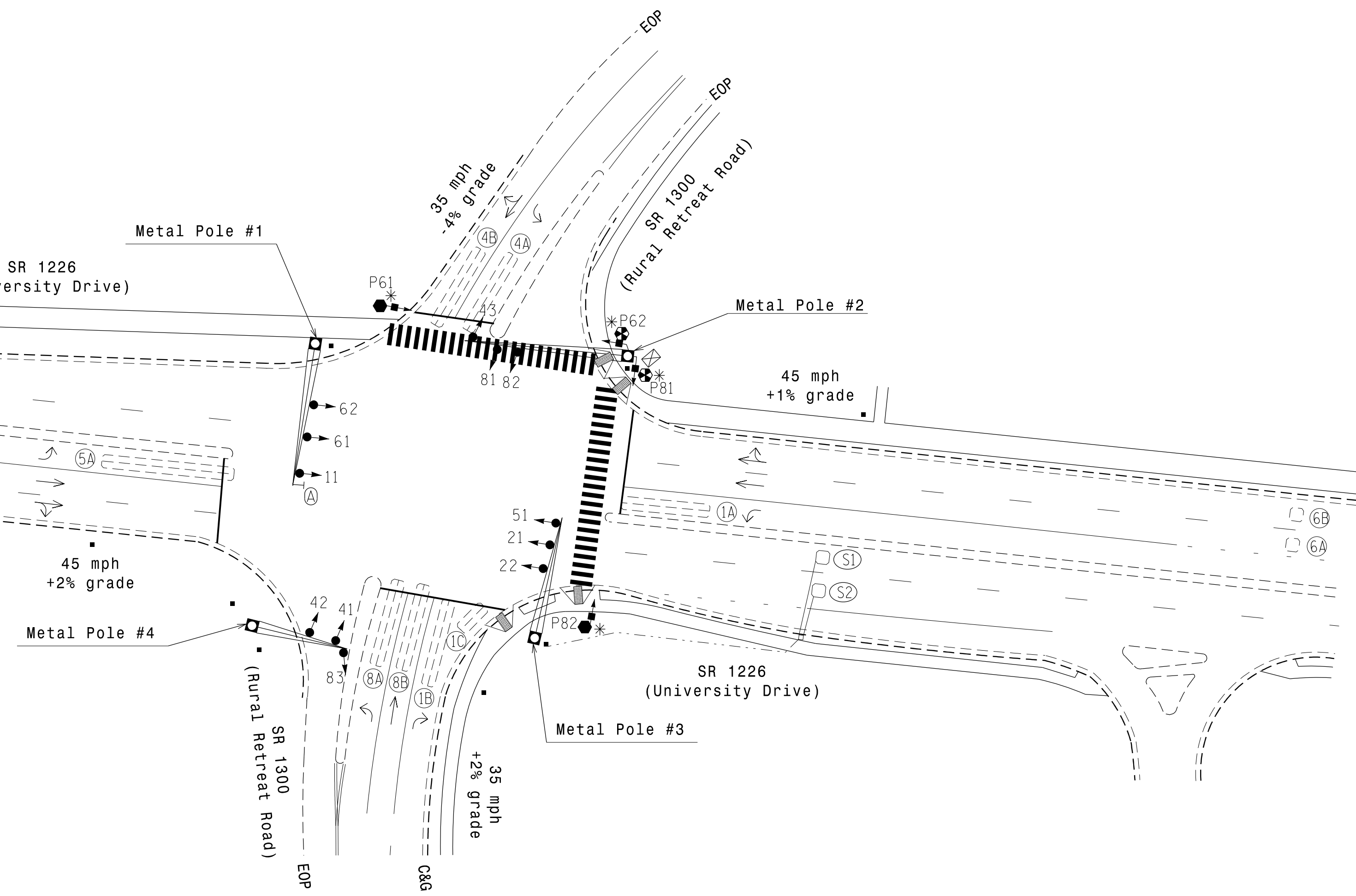

Signal Upgrade

1616 EAST MILLBROOK ROAD, SUITE 160
RALEIGH, NORTH CAROLINA 27609
(919) 876-6888 NCBES #F-0326

SR 1226 (University Drive) at SR 1300 (Rural Retreat Road)

Division 7 Alamance County Burlington

PLAN DATE: March 2018 REVIEWED BY: PL Alexander

PREPARED BY: NA Ptak REVIEWED BY: AM Encarnacion

REVISIONS: INIT. DATE

DOCUMENT NOT CONSIDERED FINAL UNLESS ALL SIGNATURES COMPLETED

SEAL
NORTH CAROLINA PROFESSIONAL ENGINEER
PAMELA L. ALEXANDER
023489

6/7/2018
DATE
SIG. INVENTORY NO. 07-2070

07-JUN-2018 11:15 U:\Projects\Traffic\Traffic\Task 05_11_Signals\Desi\Task 05_11_Signals\Task 05_11_Signals.dgn ALEX3361 AT LUS340649

