

PHASING DIAGRAM

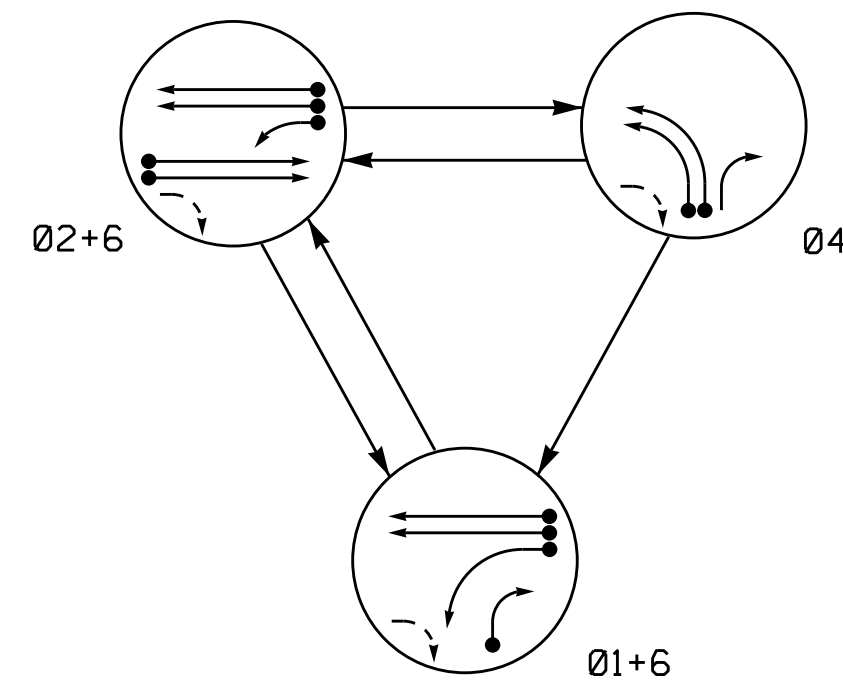

PHASING DIAGRAM DETECTION LEGEND

- → DETECTED MOVEMENT
- → UNDETECTED MOVEMENT (OVERLAP)
- - - → UNSIGNALIZED MOVEMENT
- ← - - - → PEDESTRIAN MOVEMENT

SIGNAL FACE	PHASE			
	01+6	02+6	04	LOCAL
11	←	→	→	→
21, 22	R	G	R	Y
41, 42	←	←	←	←
43	→	R	→	R
61, 62	G	G	R	Y

SIGNAL FACE I.D.

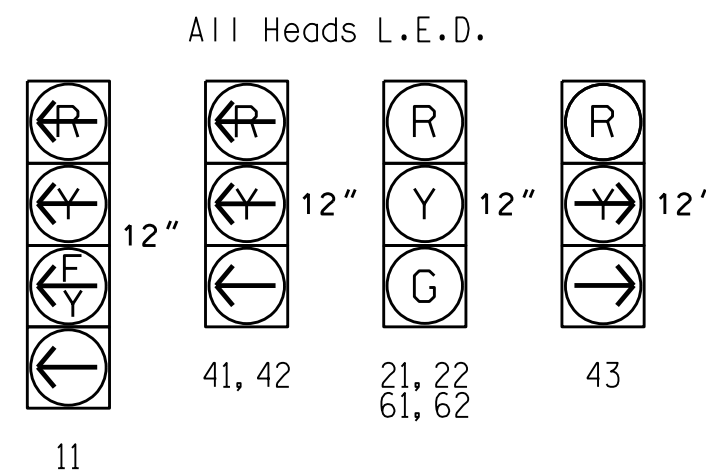

INDUCTIVE LOOPS				DETECTOR PROGRAMMING								
LOOP	SIZE (FT)	DISTANCE FROM STOPBAR (FT)	TURNS	NEW LOOP	PHASE	CALLING	EXTENSION	FULL TIME DELAY	STRETCH TIME	DELAY TIME	SYSTEM LOOP	NEW CARD
1A	6X40	0	2-4-2	Y	1	Y	Y	-	-	15	-	Y
1B	6X40	0	2-4-2	Y	1	Y	Y	-	-	15	-	Y
2A	6X6	420	6	Y	2	Y	Y	-	-	-	-	Y
2B	6X6	420	6	Y	2	Y	Y	-	-	-	-	Y
4A	6X40	0	2-4-2	Y	4	Y	Y	-	-	-	-	Y
4B	6X40	0	2-4-2	Y	4	Y	Y	-	-	-	-	Y
6A	6X6	420	6	Y	6	Y	Y	-	-	-	-	Y
6B	6X6	420	6	Y	6	Y	Y	-	-	-	-	Y
S1	6X6	200	3	Y	-	-	-	-	-	-	-	Y
S2	6X6	200	3	Y	-	-	-	-	-	-	-	Y
S3	6X6	150	5	Y	-	-	-	-	-	-	-	Y
S4	6X6	150	5	Y	-	-	-	-	-	-	-	Y

3 Phase Fully Actuated NC 42 (East of Clayton)

NOTES

- Refer to "Roadway Standard Drawings NCDOT" dated January 2018. "Standard Specifications for Roads and Structures" dated January 2018.
- Do not program signal for late night flashing operation unless otherwise directed by the Engineer.
- Phase 1 may be lagged.
- Set all detector units to presence mode.
- Locate new cabinet so as not to obstruct sight distance of vehicles turning right on red.
- Maximum times shown in timing chart are for free-run operation only. Coordinated signal system timing values supersede these values. Closed loop system data: Controller Asset #1433.

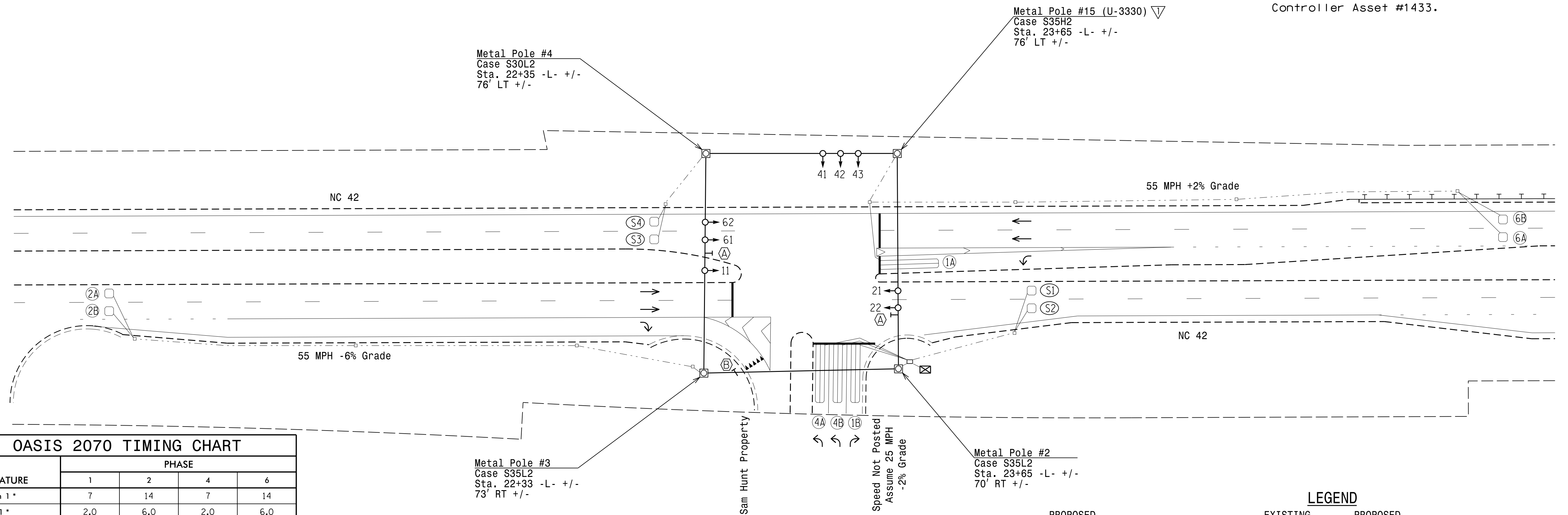

FEATURE	PHASE			
	1	2	4	6
Min Green 1 *	7	14	7	14
Extension 1 *	2.0	6.0	2.0	6.0
Max Green 1 *	25	90	45	90
Yellow Clearance	3.0	5.9	3.0	5.9
Red Clearance	2.6	1.2	3.3	1.2
Red Revert	2.0	2.0	2.0	2.0
Walk 1 *	-	-	-	-
Don't Walk 1	-	-	-	-
Seconds Per Actuation *	-	1.8	-	1.8
Max Variable Initial *	-	46	-	46
Time Before Reduction *	-	15	-	15
Time To Reduce *	-	30	-	30
Minimum Gap	-	3.4	-	3.4
Recall Mode	-	MIN RECALL	-	MIN RECALL
Vehicle Call Memory	-	YELLOW	-	YELLOW
Dual Entry	-	-	-	-
Simultaneous Gap	ON	ON	ON	ON

* These values may be field adjusted. Do not adjust Min Green and Extension times for phases 2 and 6 lower than what is shown. Min Green for all other phases should not be lower than 4 seconds.

PROPOSED		EXISTING	
	Traffic Signal Head		2-in Underground Conduit
	Metal Strain Pole Sign		Right of Way
	Inductive Loop Detector		Directional Arrow
	Controller & Cabinet Junction Box		Street Name Sign (D3-1)
	Oversized Junction Box		Yield Sign (R1-2)

New Installation

Prepared by
URS
URS Corporation - North Carolina
1600 Perimeter Park Drive
Morrisville, North Carolina 27560
TELEPHONE (919) 461-1100 FAX (919) 461-1415
NC LICENSE C-2243

REVISION SEAL
NORTH CAROLINA PROFESSIONAL SEAL 030530
ENGINEER
ZACHARY M. LITTLE
4/17/2019

Prepared for the Offices of:
Transportation Mobility and Safety
STATE OF NORTH CAROLINA
SIGNAL DESIGN SECTION
750 N. Greenfield Pkwy, Garner, NC 27529

NC 42 at Sam Hunt Property
Division 4 Johnston County Clayton
PLAN DATE: January 2018 REVIEWED BY: C. L. Kalencik
PREPARED BY: S. W. COX REVIEWED BY:

DOCUMENT NOT CONSIDERED FINAL UNLESS ALL SIGNATURES COMPLETED
Not a certified document as to the Original Document but Only as to the Revisions - This document originally Issued and sealed by Courtney Kalencik, 040715 on 5/25/2018
This document is only certified as to the revisions.
SIG. INVENTORY NO. 04-1433

17: APR-2019, 09:54 S:\IT\55\1515\Signal\45\Signal - Sect\Loc\East\Reg\Con\40\1v-04\04-1433\041433.s1.dwg, 2019mcds.dgn