

REVISION DESIGNED BY
ROADSIDE ENVIRONMENTAL UNIT
12/17/2020

Place Matting for Erosion Control
on all Cut and Fill Slopes as Work Allows.
-L- Sta. 190+00 to Sta. 203+00 RT & LT
-Y12- Sta. 11+31 to Sta. 21+00 RT & LT
-Y11C- Sta. 10+00 to Sta. 12+17 RT & LT

Place Matting for Erosion Control in
Temporary Ditches
and Diversions.

Place Matting for
Erosion Control in
Temporary Ditches
and Diversions.

Install Sod Strip in Raised Median
and Behind Guard Rail

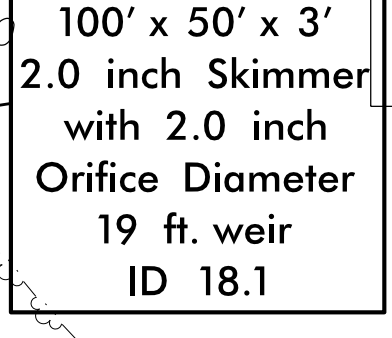
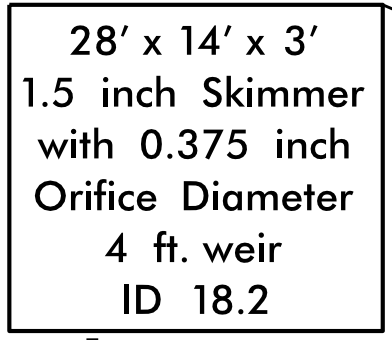
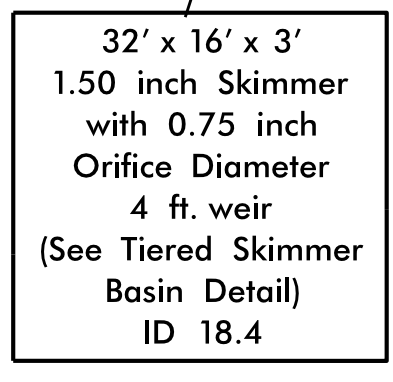
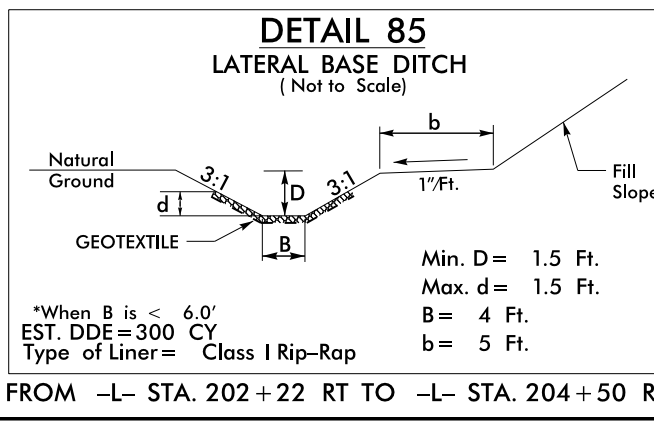
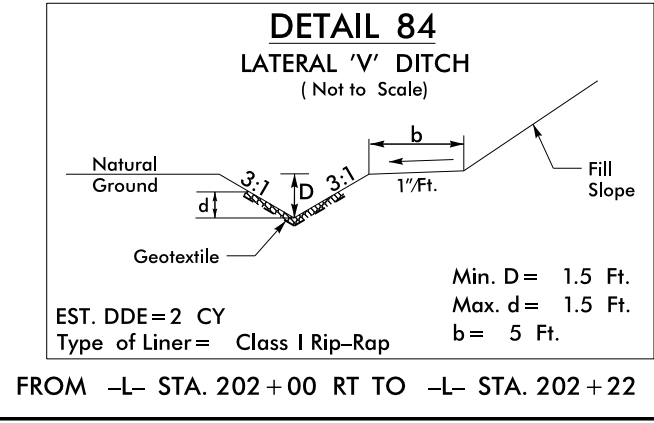
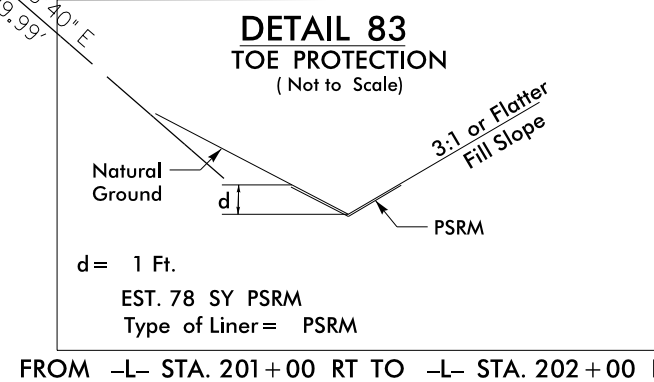
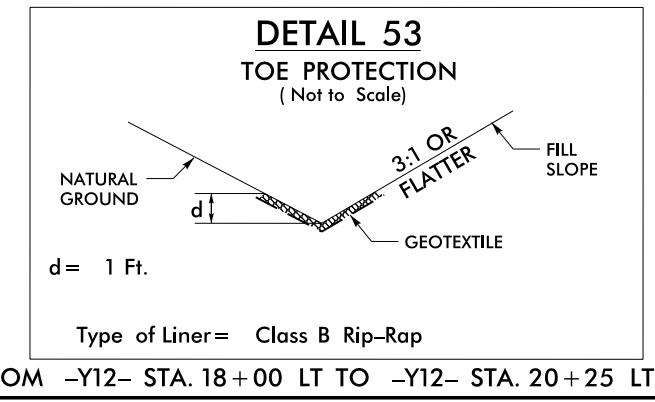
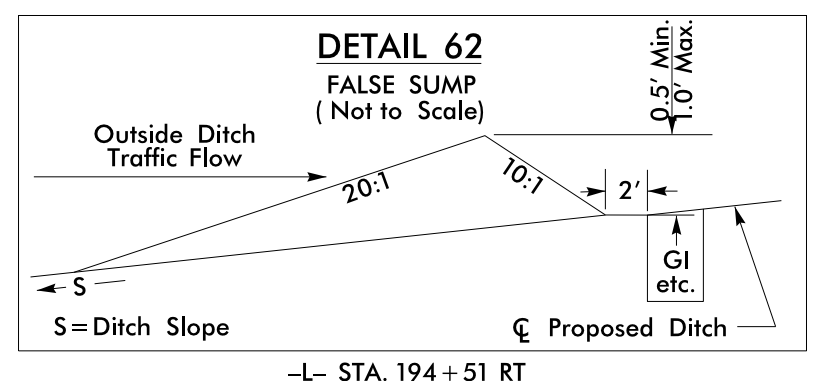
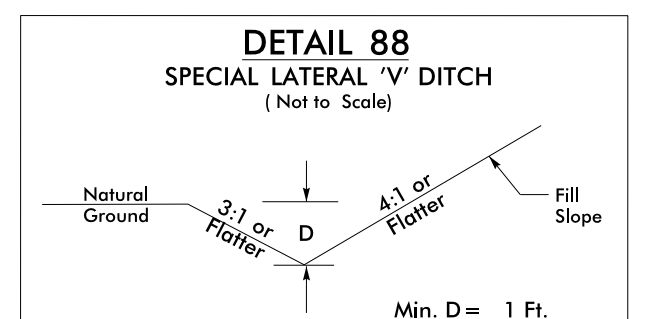
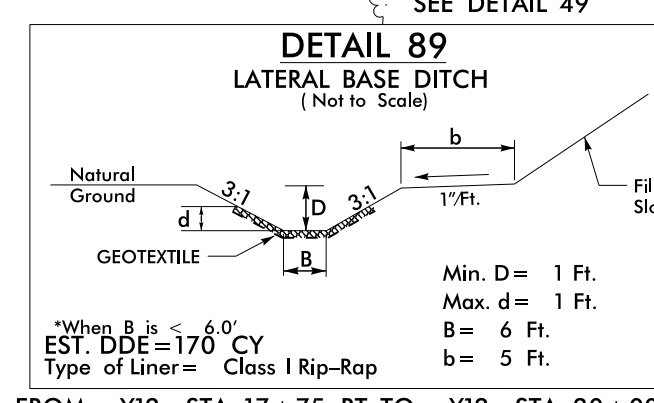
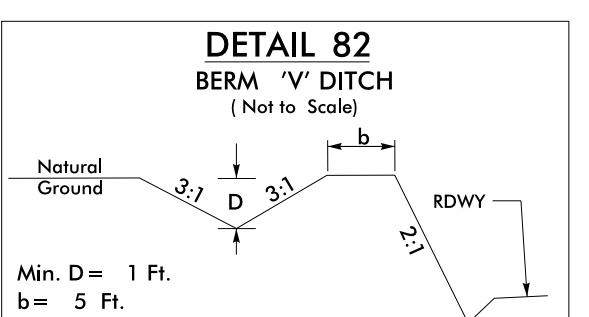
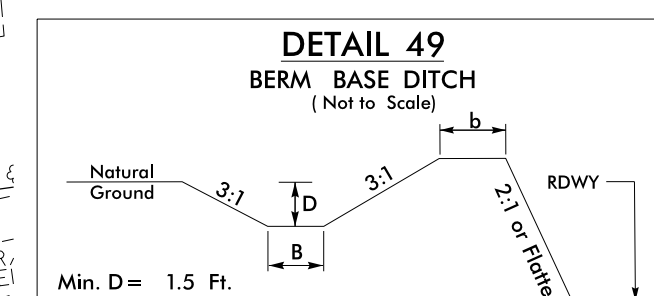
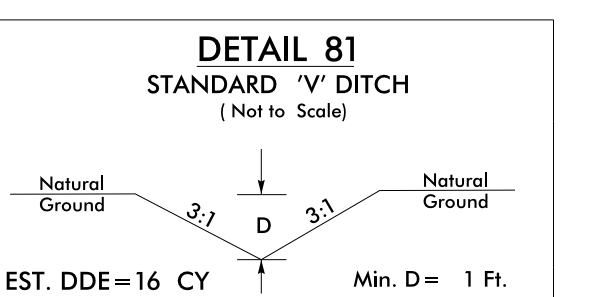
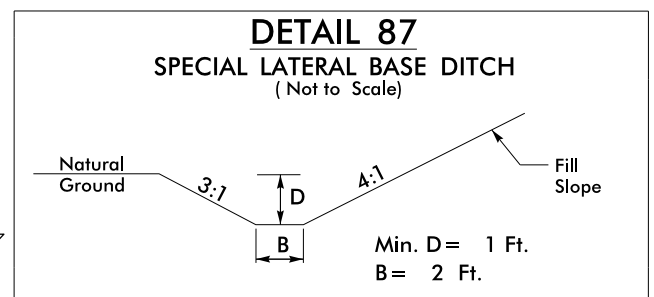
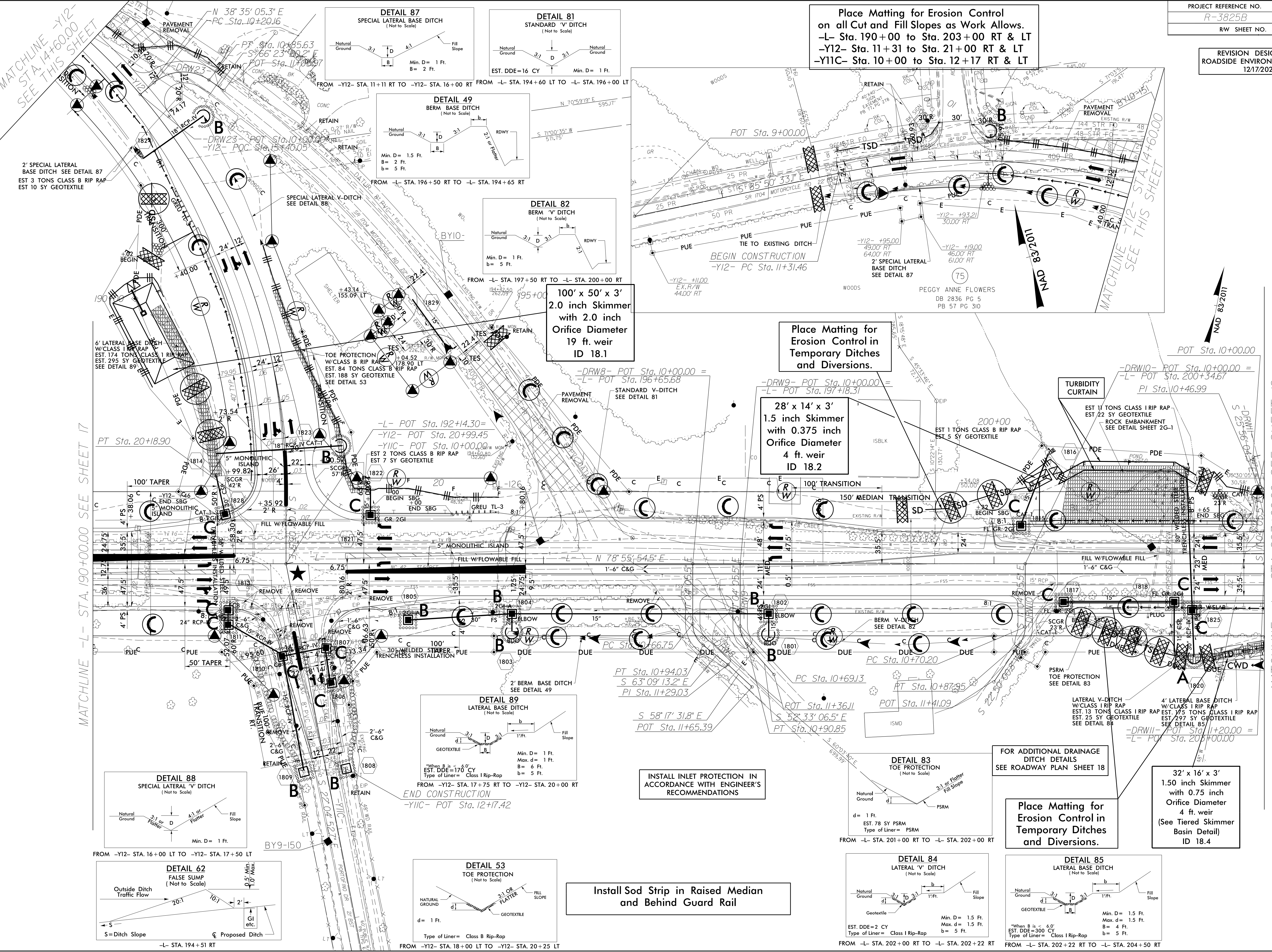

REVISIONS
02/19/2020 - CONSTRUCTION REVISION: REVISED LANE CONFIGURATION AND DRAINAGE TO INCLUDE A RIGHT TURN LANE ON -Y11C- REMOVED MEDIAN STRIPING ON -Y12- TO CONTINUE
8/17/99

MATCHLINE -L- STA. 190+00.00 SEE SHEET 17

MATCHLINE -Y12- STA. 14+60.00 SEE THIS SHEET

MATCHLINE -L- STA. 203+00.00 SEE SHEET 19