

CONFIDENTIAL AND PROPRIETARY PROPERTY OF
EBDG - NC, PLLC
 MAY NOT BE USED FOR CONSTRUCTION OR PROVIDED TO
 ANY THIRD PARTIES WITHOUT PRIOR WRITTEN CONSENT.
 ©2018 ELLIOTT BAY DESIGN GROUP.

REVISION HISTORY					
REV	ZONE	DESCRIPTION	DWN	DATE	APVD
A	SHT1 SHT2 1-2B 2-5B	1. CHANGED HATCH CUTOUT BLOCK AND CALLOUTS 2. MOVED RESCUE LADDER DECK SOCKETS ENDWARDS.	SKW	8/2/18	SKW

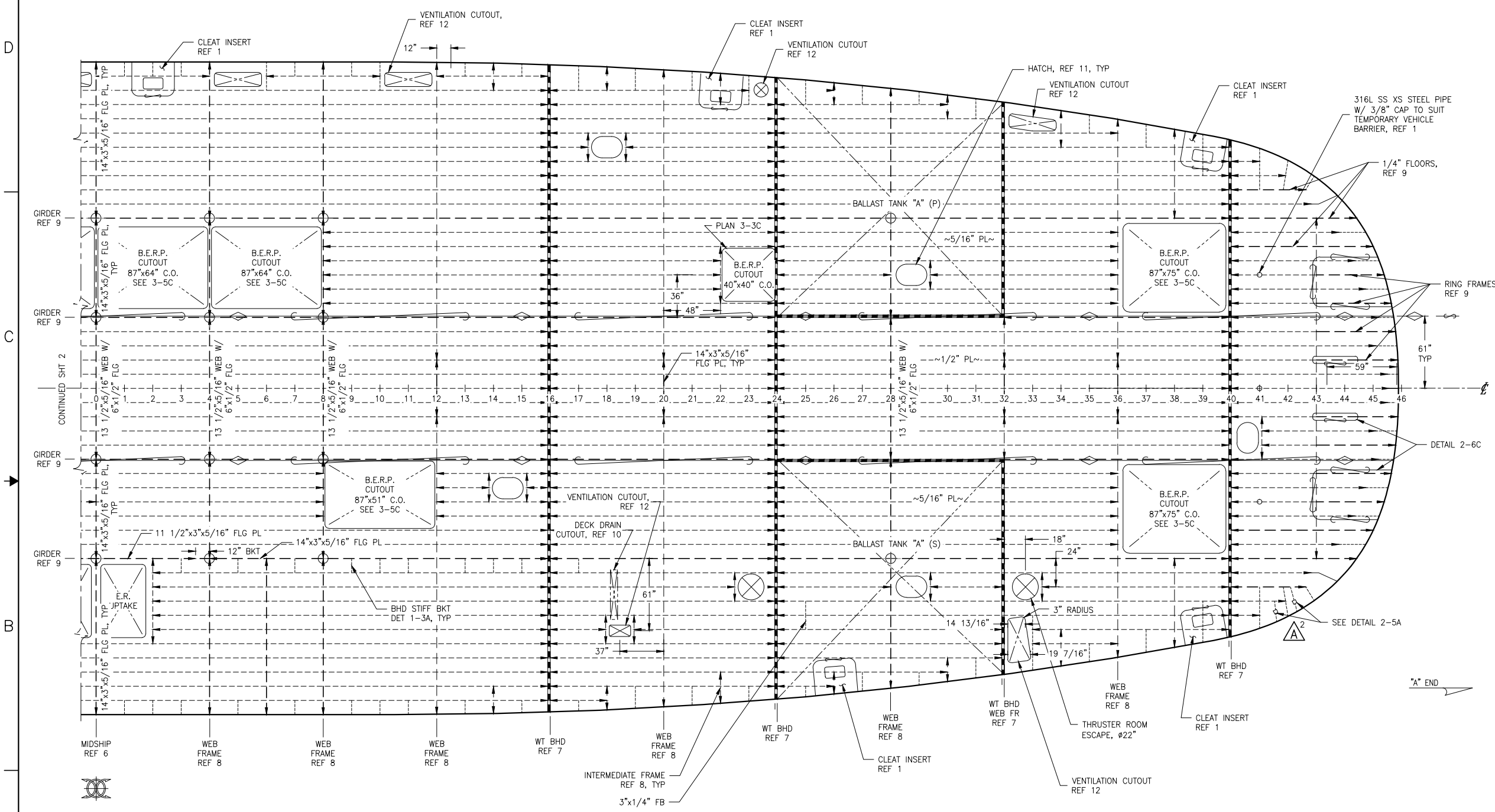

GENERAL NOTES

1. VESSEL TO BE CONSTRUCTED IN ACCORDANCE WITH 46 CFR SUBCHAPTER H REGULATIONS.
2. FRAME SPACING IS 24".
3. TOP SURFACE OF MAIN DECK TO BE FLUSH THROUGHOUT, SEE REF 1.
4. ABBREVIATION "C.O." MEANS "CLEAR OPENING"

REFERENCES

1. 18026-200-832-1 TECHNICAL SPECIFICATION
2. 18026-200-061-1 SCANTLING CALCULATIONS
3. 18026-200-100-1 LINES PLAN
4. 18026-200-101-1 PROFILES AND DECK ARRANGEMENTS
5. 18026-200-110-1 BOTTOM AND SIDE SHELL
6. 18026-200-120-1 MIDSHIP SECTION
7. 18026-200-120-3 HULL TRANSVERSE BULKHEADS
8. 18026-200-120-4 HULL TRANSVERSE FRAMES
9. 18026-200-120-5 HULL LONGITUDINAL BULKHEADS AND GIRDERS
10. 18026-200-526-1 DECK DRAIN PIPING SYSTEM
11. 18026-200-624-3 HATCH SCHEDULE
12. 18026-200-513-1 MACHINERY VENTILATION ARRANGEMENT

LEGEND

- BULKHEAD
- LONG GIRDER/ WEB FRAME
- ORDINARY STIFFENER
- BRACKET
- PLATE SEAM
- KNUCKLE
- TONNAGE FRAME
- STANCHION UNDER DECK

PLAN 1-4A
 MAIN DECK - 'A' END

MAIN DECK PL - CENTER: 1/2" TYP U.N.O.
 MAIN DECK PL - OUTBD: 5/16" TYP U.N.O.
 MAIN DECK STIFFENERS: HP140x8 TYP U.N.O.
 MAIN DECK GIRDERS & WEBS: 14"x3"x5/16" FLG PL TYP U.N.O.
 STANCHIONS - 5' OCL: 5" SCH 80 TYP U.N.O.
 STANCHIONS - 12' OCL: 4" SCH 40 TYP U.N.O.

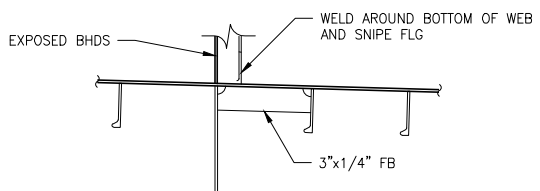

Elliott Bay Design Group
 North Carolina, PLLC

CLIENT: **NORTH CAROLINA D.O.T.**
 RALEIGH, NORTH CAROLINA

PROJECT: **DOUBLE-ENDED AZIMUTH DRIVE FERRY**



SIZE	D	DWG NO.	18026-200-130-2	REV	A
SCALE	1/4"=1'-0"	FILE NAME	18026-200-130-2A	SHEET	1 OF 3
DWN	JCG	MOD	SKW	APVD	SKW
				APVD DATE	7/26/2018

6

5

4

3

2

1

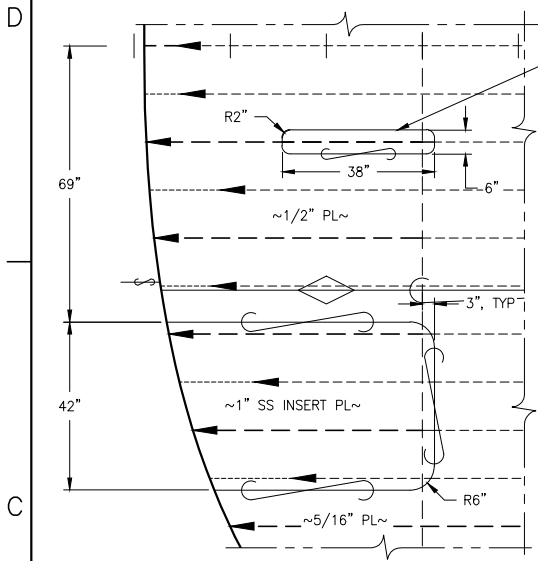

DETAIL 2-6C
 MAIN DECK LOADING ZONE
 INSERT PLATES
 SCALE: 1/2" = 1'-0"

NOTE:
 'B' END STARBOARD SHOWN
 PORT SIM./OPP.
 'A' END SIM./OPP.

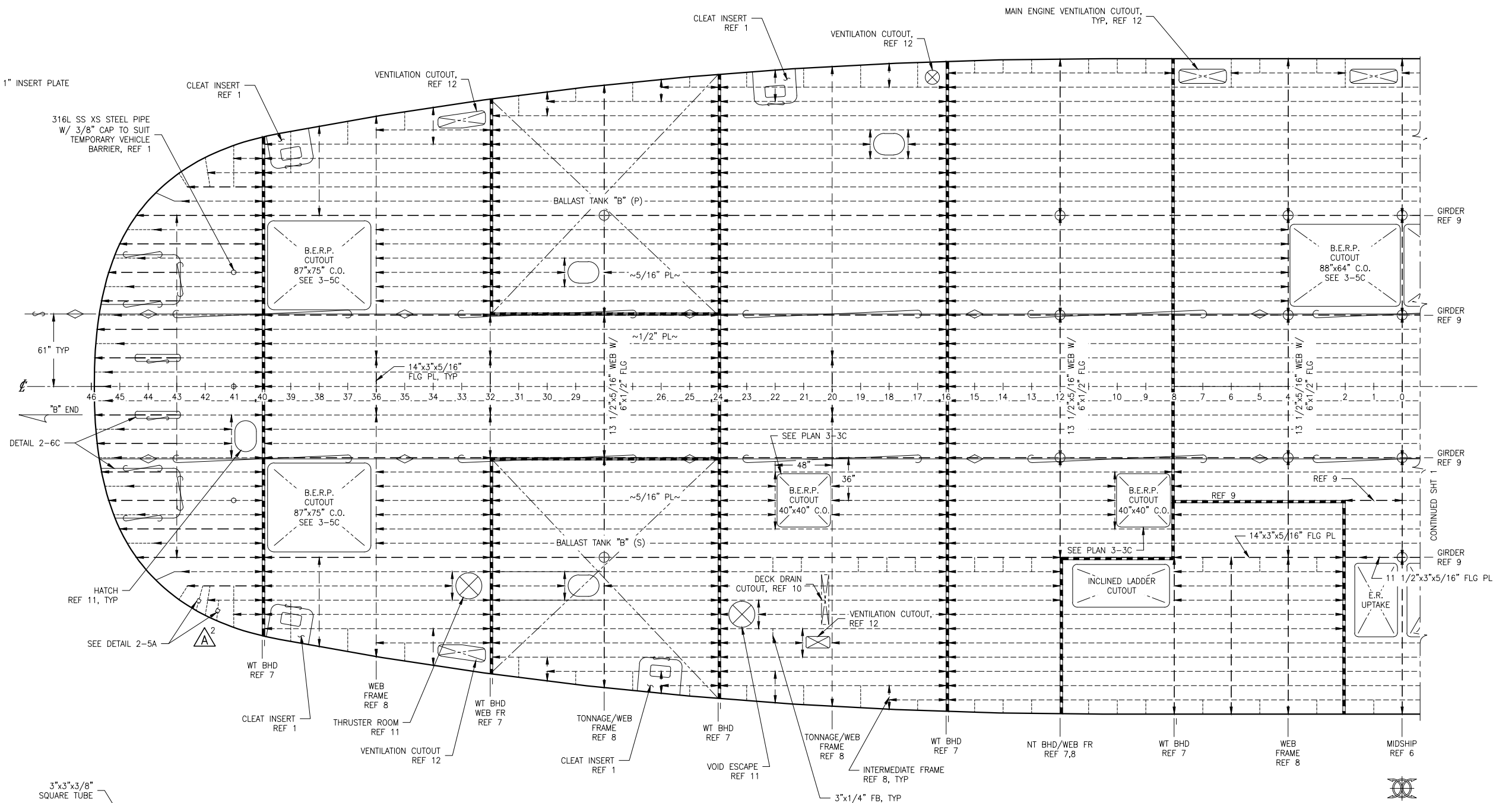

PLAN 2-3A
 MAIN DECK - 'B' END
 SCALE: 1/4" = 1'-0"

MAIN DECK PL - CENTER: 1/2" TYP U.N.O.
 MAIN DECK PL - OUTBD: 5/16" TYP U.N.O.
 MAIN DECK STIFFENERS: HP140x8 TYP U.N.O.
 MAIN DECK GIRDERS & WEBS: 14"x3"x5/16" FLG PL TYP U.N.O.
 STANCHIONS - 5' OCL: 5" SCH 80 TYP U.N.O.
 STANCHIONS - 12' OCL: 4" SCH 40 TYP U.N.O.

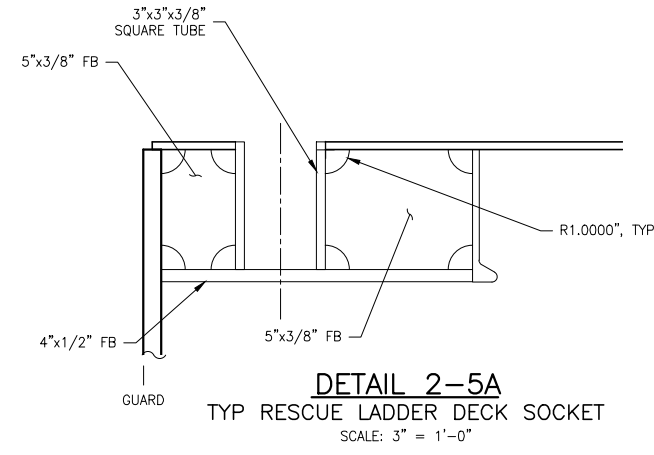

DETAIL 2-5A
 TYP RESCUE LADDER DECK SOCKET
 SCALE: 3" = 1'-0"

LEGEND

- BULKHEAD
- LONG GIRDER/ WEB FRAME
- ORDINARY STIFFENER
- BRACKET
- PLATE SEAM
- KNUCKLE
- TONNAGE FRAME
- STANCHION UNDER DECK



SIZE	D	DWG NO.	18026-200-130-2	REV	A
SCALE	AS NOTED	FILE NAME	18026-200-130-2A	SHEET	2 OF 3

8/6/2018 11:12:20 AM

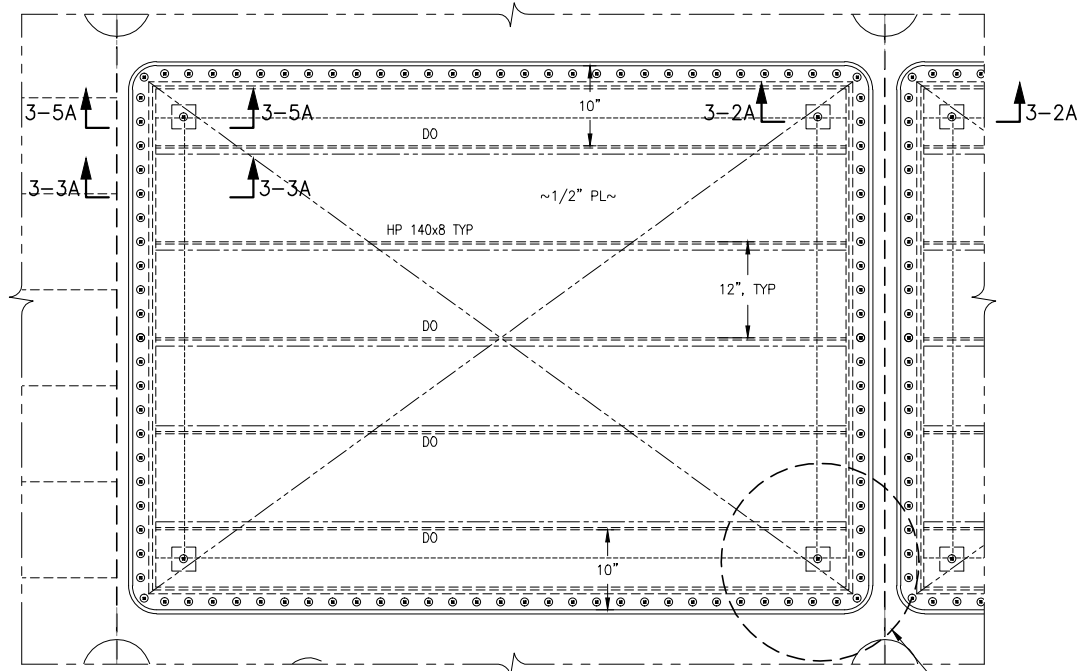

PLAN 3-5C
 GENERATOR B.E.R.P.
 ALL OTHER LARGE EQUIPMENT B.E.R.P. SIM
 1"=1'-0"

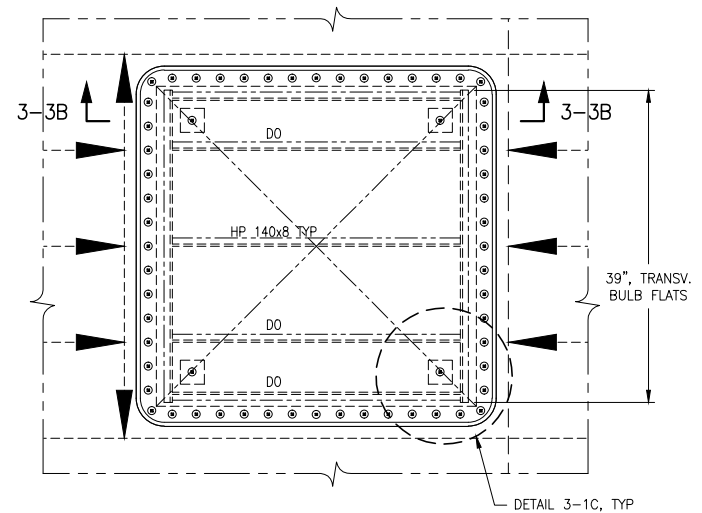

PLAN 3-3C
 SMALL EQUIPMENT REMOVAL B.E.R.P.
 SIDE B SHOWN; SIDE A ROTATE 180 ABOUT FR 0
 1"=1'-0"

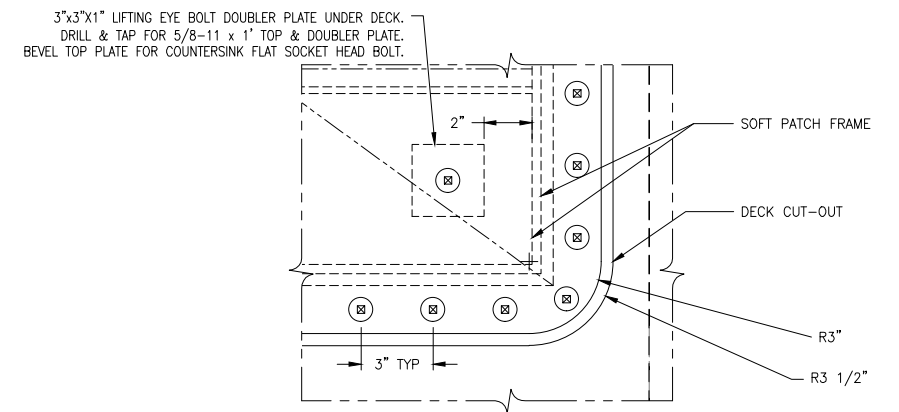

DETAIL 3-1C
 TYPICAL HATCH CORNER
 3"=1'-0"

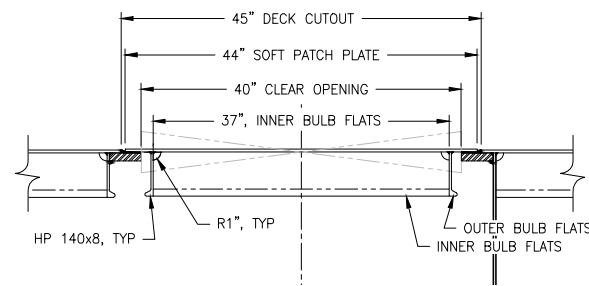

SECTION 3-3B
 TYPICAL FRAME
 1"=1'-0"

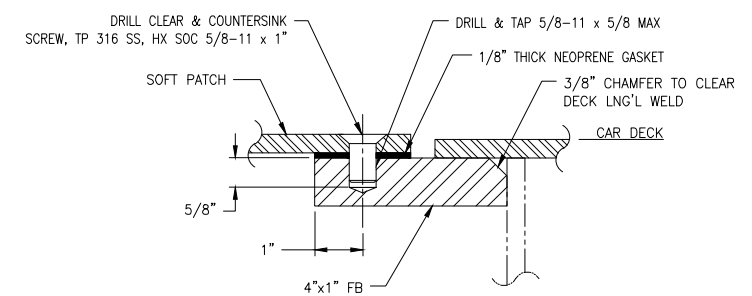

DETAIL 3-5B
 6"=1'-0"

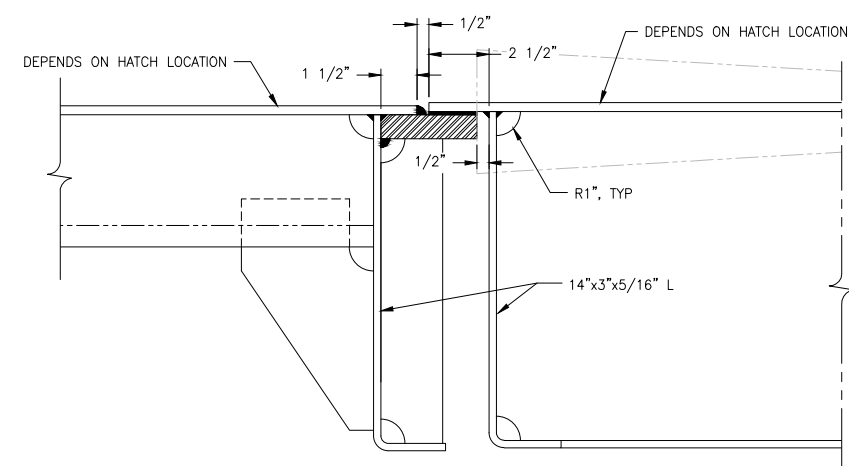

DETAIL 3-5A
 TYPICAL HATCH SUPPORT
 3"=1'-0"

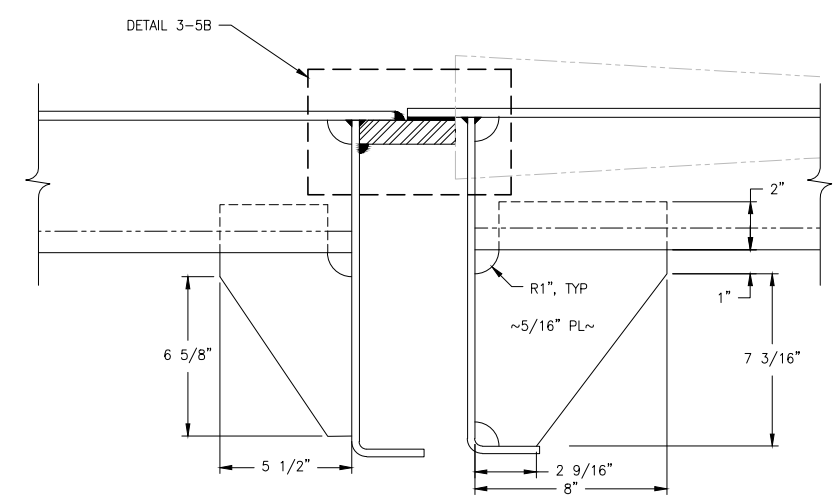

DETAIL 3-3A
 TYPICAL BRACKET DETAIL
 3"=1'-0"

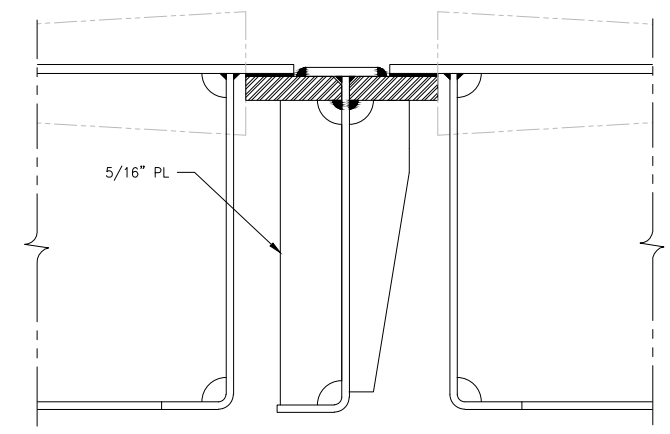

DETAIL 3-2A
 TYPICAL BRACKET DETAIL
 3"=1'-0"

