

PHASING DIAGRAM

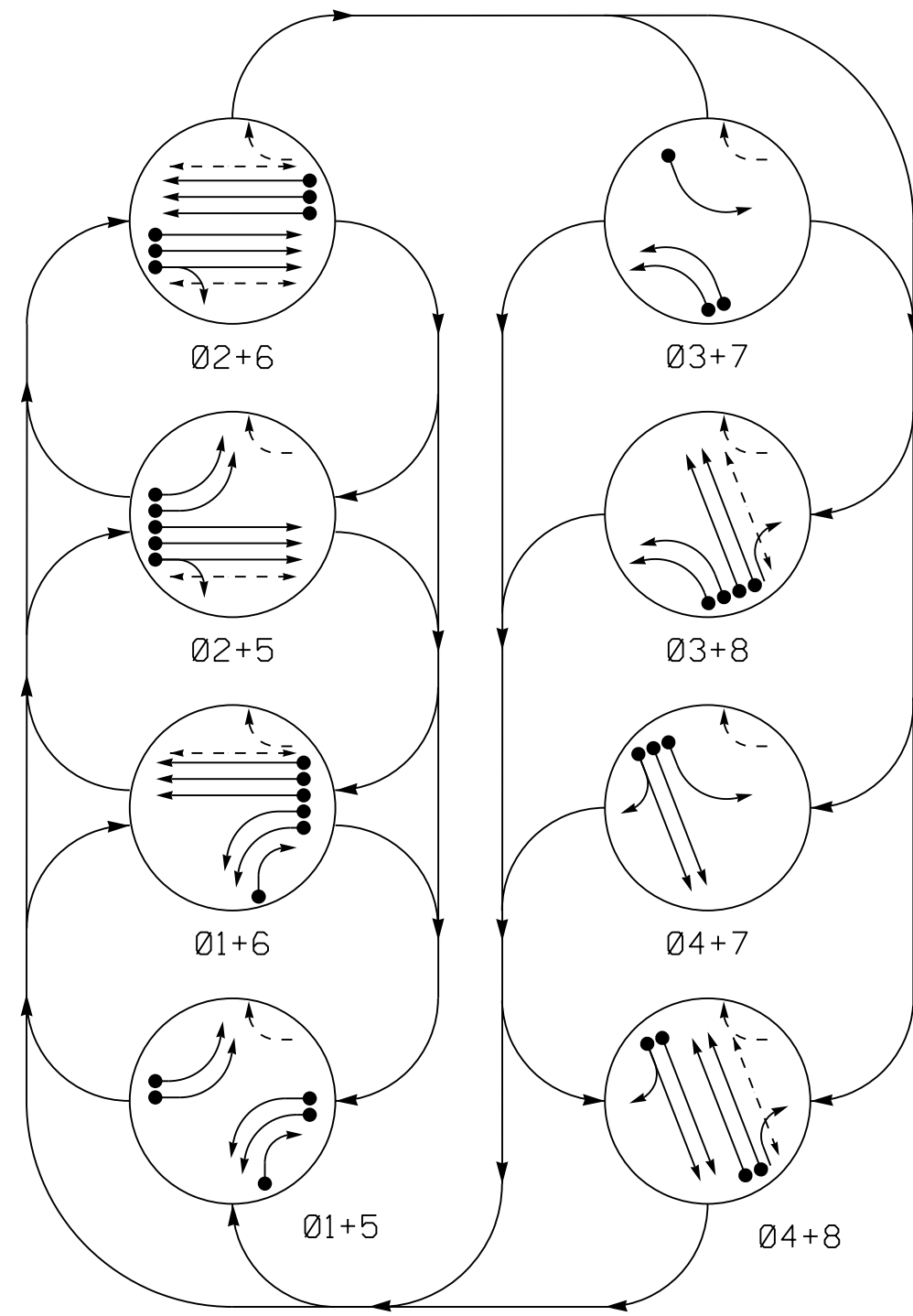

RAIL PREEMPT PHASES
(High Priority)

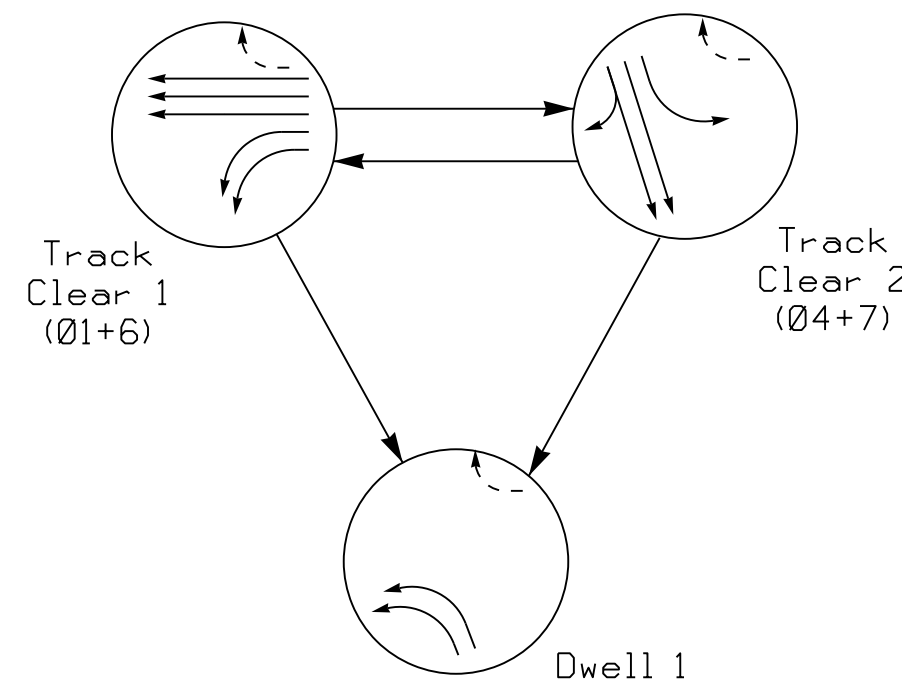

PHASING DIAGRAM DETECTION LEGEND

- DETECTED MOVEMENT
- ◀ UNDETECTED MOVEMENT (OVERLAP)
- ◀ - - UNSIGNALIZED MOVEMENT
- ◀ - - - PEDESTRIAN MOVEMENT

SIGNAL FACE I.D.

All Heads L.E.D.

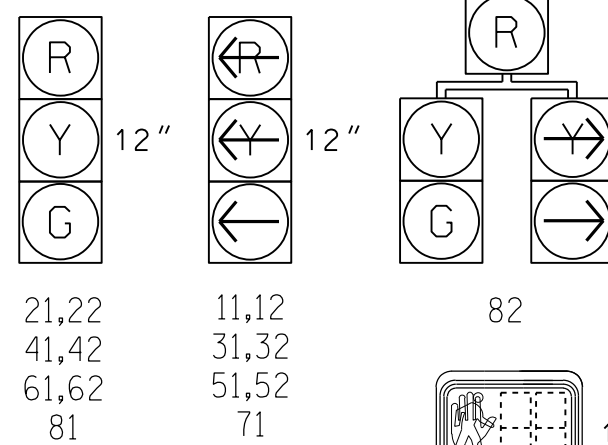

TABLE OF OPERATION

SIGNAL FACE	PHASE											
	01+5	01+6	02+5	02+6	03+7	03+8	04+7	04+8	04+9	04+10	04+11	04+12
11,12	←	←	←	←	←	←	←	←	←	←	←	←
21,22	R	R	G	G	R	R	R	R	R	R	R	Y
31,32	←	←	←	←	←	←	←	←	←	←	←	←
41,42	R	R	R	R	G	G	R	G	R	R	R	R
51,52	←	←	←	←	←	←	←	←	←	←	←	←
61,62	R	G	R	G	R	R	R	R	G	R	R	Y
71	←	←	←	←	←	←	←	←	←	←	←	←
81	R	R	R	R	G	R	G	R	R	R	R	R
82	R	R	R	R	G	R	G	R	R	R	R	R
P21,P22	DW	DW	W	W	DW	DW	DW	DW	DW	DW	DRK	DRK
P61,P62	DW	W	DW	W	DW	DW	DW	DW	DW	DW	DRK	DRK
P81,P82	DW	DW	DW	DW	DW	W	DW	W	DW	DW	DRK	DRK
Sign (A)	OFF	OFF	OFF	OFF	OFF	OFF	OFF	OFF	ON	ON	ON	*

* See Note 8

ASC/3 DETECTOR INSTALLATION CHART

LOOP	SIZE (FT)	DISTANCE FROM STOPBAR (FT)	TURNS	NEW LOOP	PROGRAMMING							
					PHASE	CALLING	EXTEND TIME	DELAY TIME	USE ADDED INITIAL	TYPE	SYSTEM LOOP	NEW CARD
1A	6X40	0	2-4-2	X	1	Yes	-	-	-	S	-	X
1B	6X40	0	2-4-2	X	1	Yes	-	-	-	S	-	X
1C	6X40	0	2-4-2	X	1	Yes	-	15	-	S	-	X
2A	6X6	70	5	X	2	Yes	-	-	-	S	-	X
2B	6X6	70	5	X	2	Yes	-	-	-	S	-	X
2C	6X6	70	5	X	2	Yes	-	-	-	S	-	X
3A	6X40	0	2-4-2	X	3	Yes	-	3	-	S	-	X
3B	6X40	0	2-4-2	X	3	Yes	-	-	-	S	-	X
4A	6X6	0	4	X	4	Yes	-	-	-	S	-	X
4B	6X6	0	4	X	4	Yes	-	10	-	S	-	X
4C	6X15	0	2-4-2	X	4	Yes	-	15	-	S	-	X
5A	6X40	0	2-4-2	X	5	Yes	-	-	-	S	-	X
5B	6X40	0	2-4-2	X	5	Yes	-	-	-	S	-	X
6A	6X6	70	3	X	6	Yes	-	-	-	S	-	X
6B	6X6	70	3	X	6	Yes	-	-	-	S	-	X
6C	6X6	70	3	X	6	Yes	-	-	-	S	-	X
7A	6X40	0	2-4-2	X	7	Yes	-	3	-	S	-	X
8A	6X6	0	4	X	8	Yes	-	-	-	S	-	X
8B	6X6	0	4	X	8	Yes	-	-	-	S	-	X

8 Phase Fully Actuated w/ Railroad Preemption Fayetteville Signal System

NOTES

- Refer to "Roadway Standard Drawings NCDOT" dated January 2018 and "Standard Specifications for Roads and Structures" dated January 2018.
- This location contains railroad preemption phasing. Do not program signal for late night flashing operation.
- Phase 1 and/or Phase 5 may be lagged.
- Phase 3 and/or Phase 7 may be lagged.
- Set all detector units to presence mode.
- Omit "WALK" and flashing "DON'T WALK" with no pedestrian calls.
- Program pedestrian heads to countdown the flashing "DON'T WALK" time only.
- Ensure flashing operation does not alter operation of blankout signs.
- Maximum times shown in timing chart are for free-run operation only. Coordinated signal system timing values supersede these values.
- Pedestrian pedestals are conceptual and shown for reference only. See 2018 NCDOT Roadway Standard Drawings 1705.04 Sheets 1-3 for push button location details.
- Directional clearance shall be provided during preemption to allow crossing closest to approaching train to clear first. Sequence 1 shall clear crossing 847 201H (Raeford Road) first. Sequence 2 shall clear crossing 847 200B (McPherson Church Road) first.

ASC/3 RR PREEMPT

FUNCTION	SEQUENCE 1	SEQUENCE 2
Exit Phase(s)	4,8	4,8
Preempt Override	OFF	OFF
Delay Time	0	0
Ped Clear Trough Yellow	Y	Y
Terminate Phases	N	N
Track Clear Reserve	Y	Y
Entrance Walk	1	1
Entrance Ped Clear	3.0	3.0
Entrance Min Green	1	1
Entrance Yellow Change	25.5*	25.5*
Entrance Red Clear	25.5*	25.5*
Track Clear Min Green 1	35	19
Track Clear Yellow Change 1	3.8	4.6
Track Clear Red Clear 1	2.5	2.3
Track Clear Min Green 2	19	35
Track Clear Yellow Change 2	4.6	3.8
Track Clear Red Clear 2	2.3	2.5
Min Dwell Time	7	7
Exit Yellow Change	25.5*	25.5*
Exit Red Clear	25.5*	25.5*

* Time defaults to time used for phase during normal operation.

ASC/3 TIMING CHART

FEATURE	PHASE							
	1	2	3	4	5	6	7	8
Min Green *	7	10	7	7	7	10	7	7
Walk *	-	10	-	-	-	10	-	7
Ped Clear	-	28	-	-	-	30	-	28
Veh. Extension *	2.0	3.0	2.0	2.0	2.0	3.0	2.0	2.0
Max I *	15	45	15	25	15	45	15	25
Yellow	3.0	3.9	3.0	4.6	3.0	3.8	3.0	4.3
Red Clear	3.3	2.8	3.9	2.2	3.3	2.2	3.9	2.0
Red Revert	-	-	-	-	-	-	-	-
Actuations B4 Add *	-	-	-	-	-	-	-	-
Seconds /Actuation *	-	-	-	-	-	-	-	-
Max Initial *	-	-	-	-	-	-	-	-
Time Before Reduction *	-	-	-	-	-	-	-	-
Time To Reduce *	-	-	-	-	-	-	-	-
Minimum Gap	-	-	-	-	-	-	-	-
Locking Detector	-	X	-	-	-	X	-	-
Recall Position	-	VEH. RECALL	-	-	-	VEH. RECALL	-	-
Dual Entry	-	-	-	-	-	-	-	-
Simultaneous Gap	X	X	X	X	X	X	X	X

* These values may be field adjusted. Do not adjust Min Green and Extension times for phases 2 and 6 lower than what is shown. Min Green for all other phases should not be lower than 4 seconds.

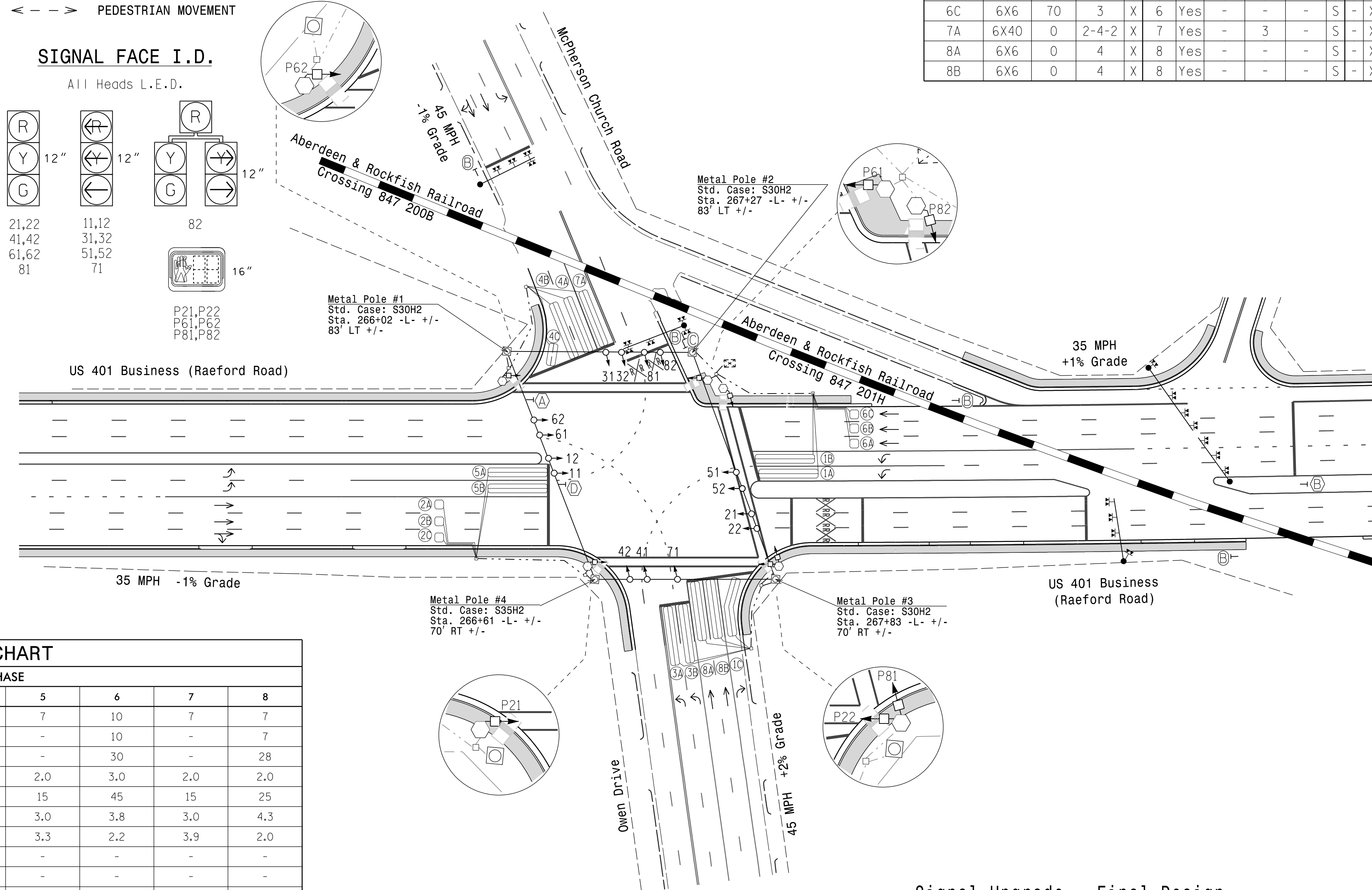

LEGEND

- | PROPOSED | EXISTING |
|--|----------|
| ○ → Traffic Signal Head | ● → N/A |
| ○ → Modified Signal Head | ○ → N/A |
| ○ → Pedestrian Signal Head With Push Button & Sign | ○ → N/A |
| ○ → Signal Pole with Guy | ○ → N/A |
| ○ → Signal Pole with Sidewalk Guy | ○ → N/A |
| ○ → Inductive Loop Detector | ○ → N/A |
| ○ → Controller & Cabinet | ○ → N/A |
| ○ → Junction Box | ○ → N/A |
| ○ → 2-in Underground Conduit | ○ → N/A |
| ○ → Right of Way | ○ → N/A |
| ○ → Directional Arrow | ○ → N/A |
| ○ → Metal Strain Pole | ○ → N/A |
| ○ → Railroad Cantilever | ○ → N/A |
| ○ → Railroad Tracks | ○ → N/A |
| ○ → Type II Signal Pedestal | ○ → N/A |
| ○ → "NO RIGHT TURN - TRAIN" L.E.D. Blankout Sign | ○ → N/A |
| ○ → "DO NOT STOP ON TRACKS" Sign (R8-8) | ○ → N/A |
| ○ → "Stop Here on Red" Sign (R10-6) | ○ → N/A |
| ○ → "U-TURN YIELD TO RIGHT TURN" Sign (R10-16) | ○ → N/A |

This signal is designed for simultaneous preemption

Signal Upgrade - Final Design

<p>Stantec Consulting Services Inc. 801 Jones Franklin Road-Suite 300 Raleigh, NC 27606 Tel. (919) 851-6866 Fax. (919) 851-7024 www.stantec.com License No. F-0672</p>		<p>US 401 Business (Raeford Road) at McPherson Church Road/ Owen Drive</p>	
		<p>Division 6 Cumberland County Fayetteville</p> <p>PLAN DATE: March 2018 REVIEWED BY: E D Harris</p> <p>PREPARED BY: G B Spell REVIEWED BY: B L Watson</p>	<p>3/29/2018</p> <p>DATE</p>

3/29/2018
 U:\Projects\4405\Signal\Drawings\Signal\Signal - Design\4405_Sig.dwg
 User: rfmancey

DOCUMENT NOT CONSIDERED FINAL UNLESS ALL SIGNATURES COMPLETED

SIG. INVENTORY NO. 06-0054