

6/2/19

PROJECT REFERENCE NO. U-4405	SHEET NO. 2A-3
ROADWAY DESIGN ENGINEER SEAL 024929 CLARK H. MORRISON 6/15/2018	PAVEMENT DESIGN ENGINEER SEAL 022896 CLARK H. MORRISON 6/15/2018
DOCUMENT NOT CONSIDERED FINAL UNLESS ALL SIGNATURES COMPLETED	

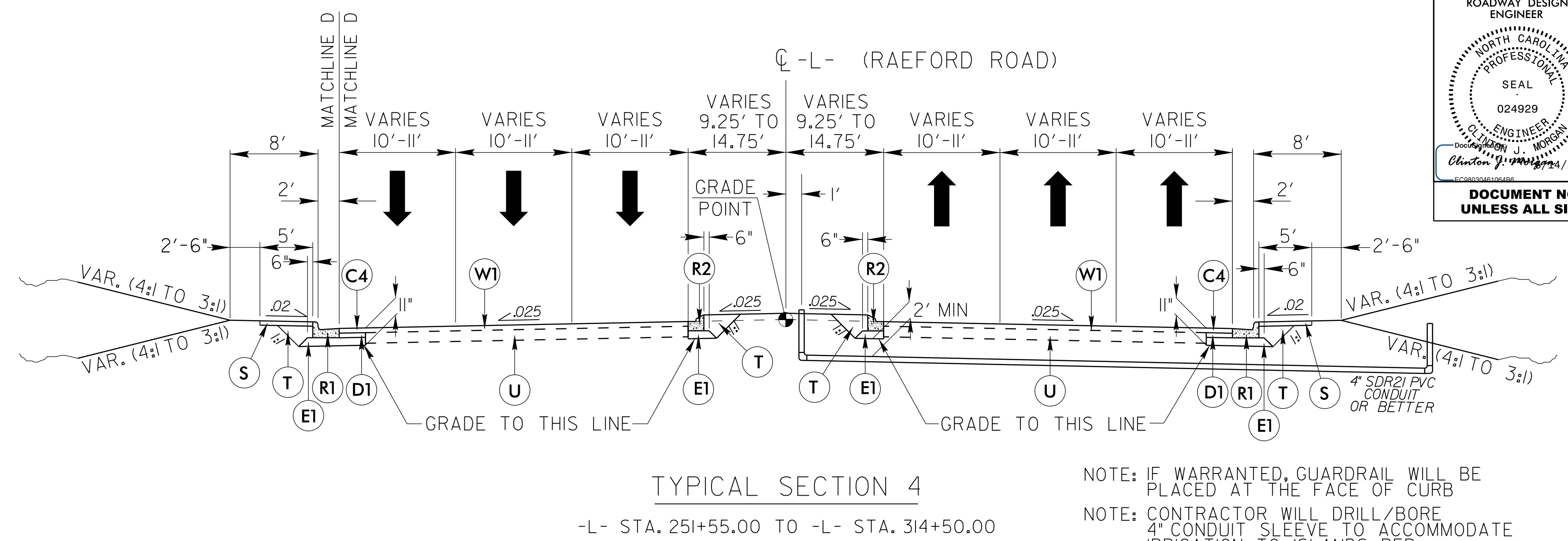

NOTE: IF WARRANTED, GUARDRAIL WILL BE PLACED AT THE FACE OF CURB
NOTE: CONTRACTOR WILL DRILL/BORE 4" CONDUIT SLEEVE TO ACCOMMODATE IRRIGATION TO ISLANDS PER RESIDENT ENGINEER DIRECTION.

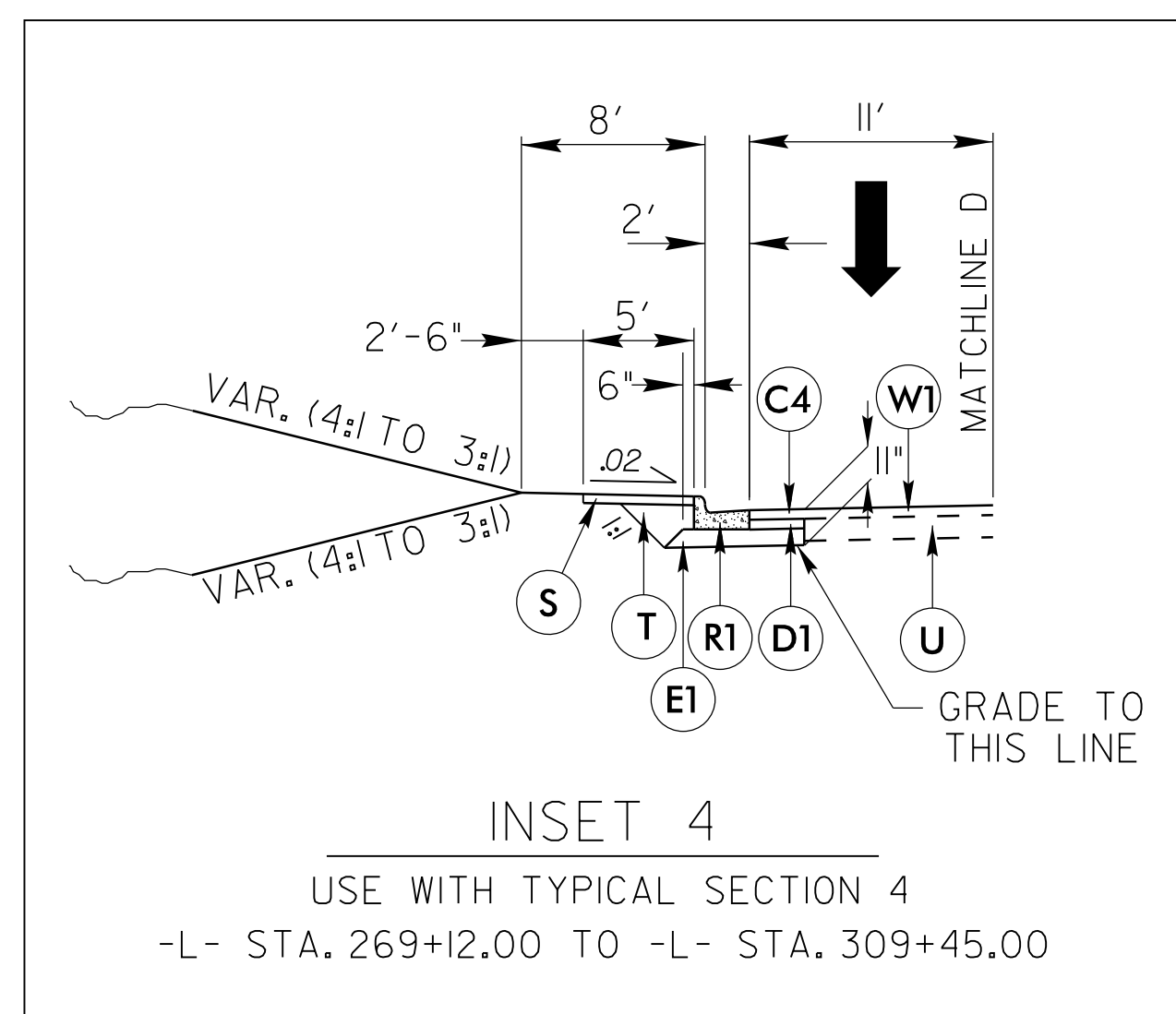
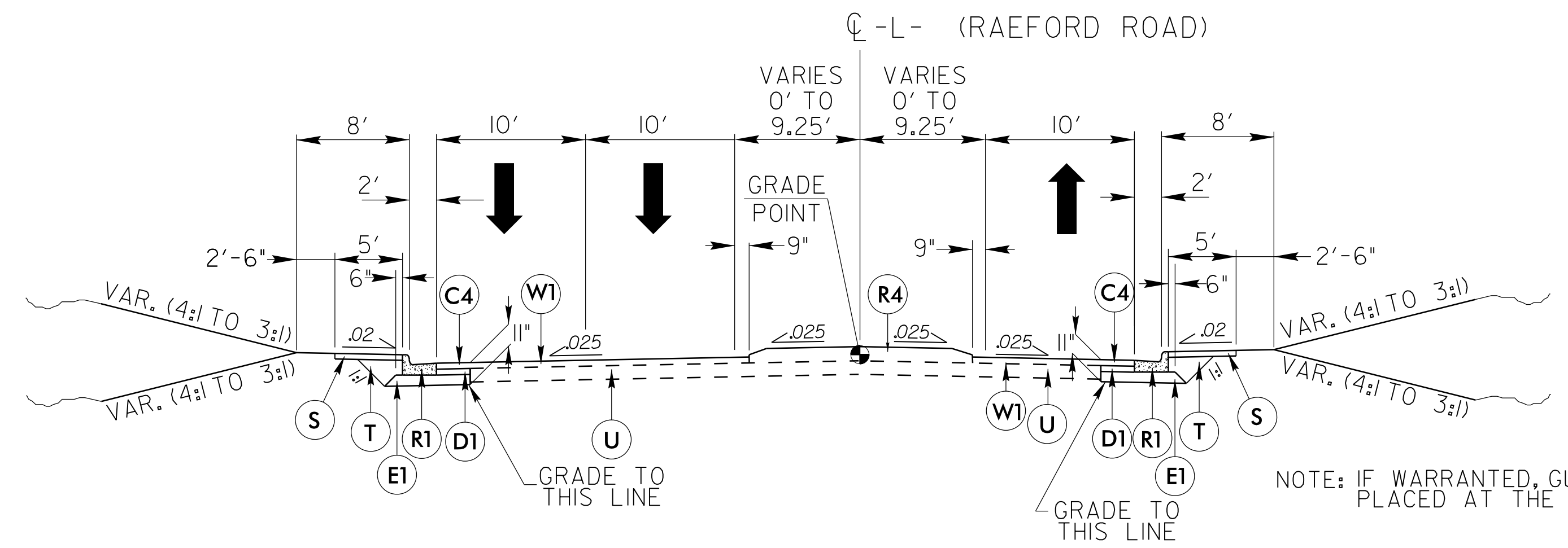

NOTE: IF WARRANTED, GUARDRAIL WILL BE PLACED AT THE FACE OF CURB

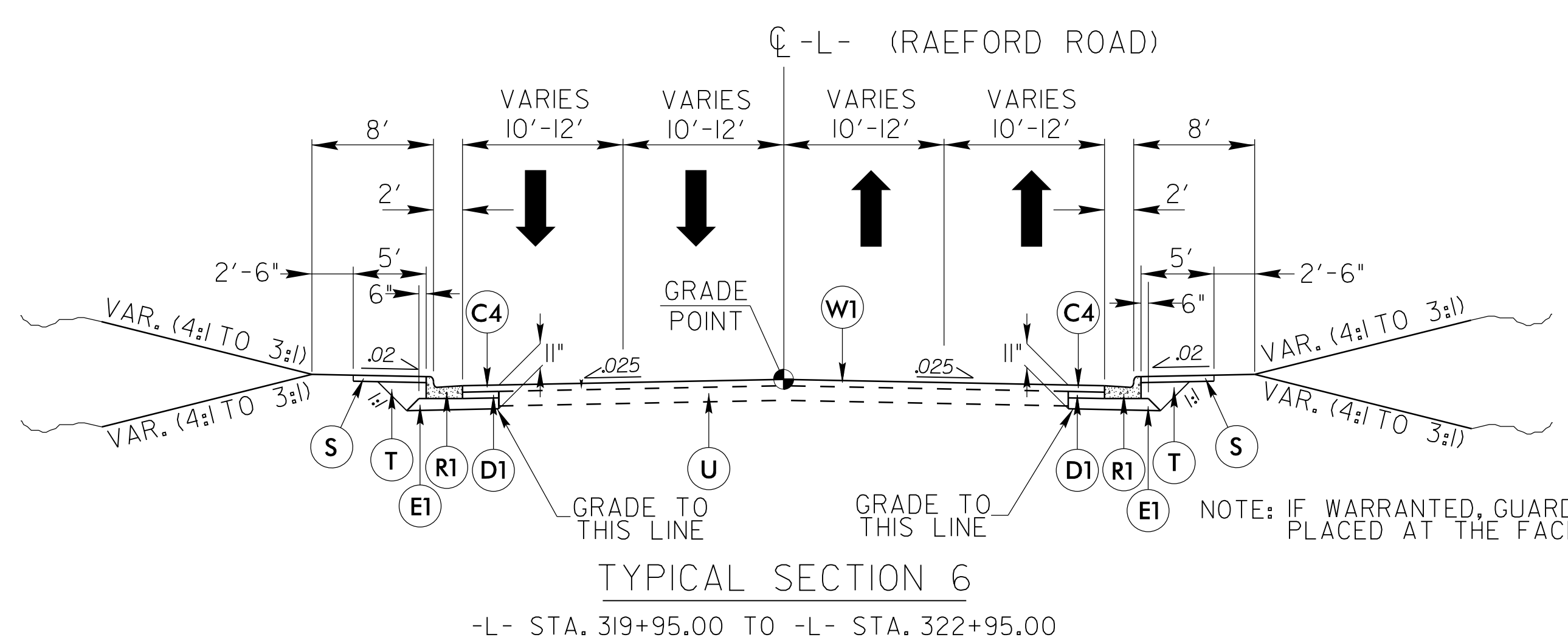

NOTE: IF WARRANTED, GUARDRAIL WILL BE PLACED AT THE FACE OF CURB

PAVEMENT SCHEDULE	
C4	3" S9.5C
D1	4" 119.0C
E1	4" B25.0C
R1	2'-6" CURB AND GUTTER
R2	1'-6" CURB AND GUTTER
R4	MONOLITHIC ISLAND (KEYED IN)
S	SIDEWALK
T	EARTH MATERIAL
U	EXISTING PAVEMENT
W1	WEDGING

14-JUN-2018 2:29 PM
 R:\Roadway\19\U4405.rdw - typ.dgn
 \$\$\$\$\$\$