

**This electronic collection of documents is provided
for the convenience of the user
and is Not a Certified Document –**

**The documents contained herein were originally issued
and sealed by the individuals whose names and license
numbers appear on each page, on the dates appearing
with their signature on that page.**

**This file or an individual page
shall not be considered a certified document.**

ECONOLITE ASC/3-2070 OVERLAP PROGRAMMING DETAIL

(program controller as shown)

1. From Main Menu select 2. CONTROLLER
2. From CONTROLLER Submenu select 2. VEHICLE OVERLAPS

Toggle Twice

OVERLAP C

Select TMG VEH OVLP [C] and 'PPLT FYA'

```

TMG VEH OVLP...[C] TYPE: ....PPLT FYA
PROTECTED LEFT TURN.... PHASE 5
OPPOSING THROUGH..... PHASE 6

FLASHING ARROW OUTPUT.....CH11 ISOLATE
DELAY START OF: FYA..0.0 CLEARANCE..0.0
ACTION PLAN SF BIT DISABLE..... 0
    
```

END PROGRAMMING

THIS ELECTRICAL DETAIL IS FOR
 THE SIGNAL DESIGN: B-0007
 DESIGNED: January 2018
 SEALED: 6/7/2018
 REVISED: N/A

09-JUN-2018 14:17
 D:\P\consort\at\off\c\curr\100056469 U-6015 B-G Sig Sys\Task 05_11_Signal\Des\gn\w\tr\In\g\B-0007E.dgn
 ALEX3361 AT LUS310649

Electrical Detail - Sheet 2 of 2

ATKINS 1616 EAST MILLBROOK ROAD, SUITE 160
 RALEIGH, NORTH CAROLINA 27609
 (919) 876-6888 NCBEE #F-0326

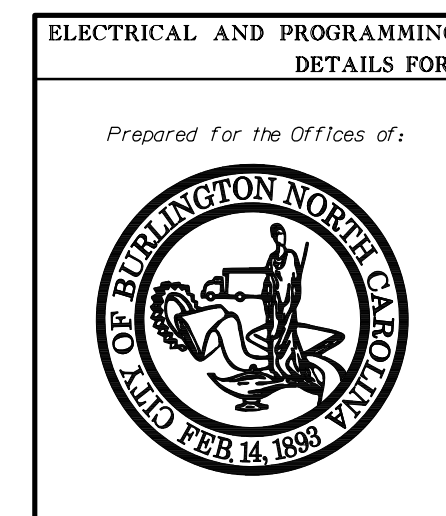

Delaney Drive at Smith Elementary School	
Division 7 Alamance County Burlington	
PLAN DATE: January 2018	REVIEWED BY: AM Encarnacion
PREPARED BY: NA Ptak	REVIEWED BY: PL Alexander
REVISIONS	INIT. DATE

DOCUMENT NOT CONSIDERED
FINAL UNLESS ALL
SIGNATURES COMPLETED

Classified by
 Pamela Alexander 6/9/2018
DATE

SIG. INVENTORY NO. B-0007

PHASING DIAGRAM

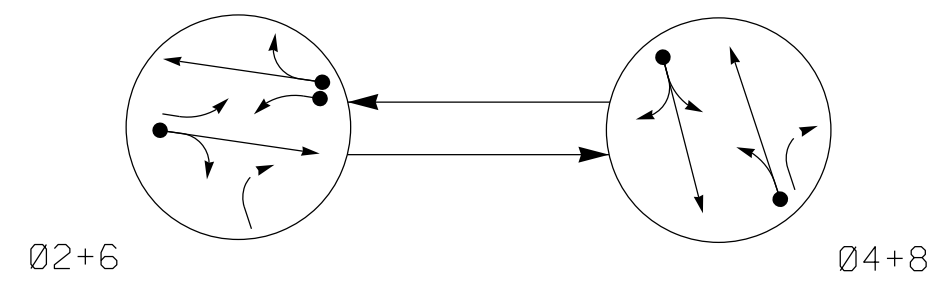

PHASING DIAGRAM DETECTION LEGEND

- ← DETECTED MOVEMENT
- ← UNDETECTED MOVEMENT (OVERLAP)
- ← UNSIGNALIZED MOVEMENT
- ⚡ ← PEDESTRIAN MOVEMENT

TABLE OF OPERATION

SIGNAL FACE	PHASE		
	02+6	04+8	FLASH
21, 22	G	R	Y
41, 42, 43	R	G	R
61, 62	G	R	Y
81, 82	R	G	R

SIGNAL FACE I.D.

All Heads L.E.D.

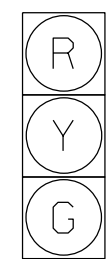

21, 22
41, 42, 43
61, 62
81, 82

ASC/3 DETECTOR INSTALLATION CHART

LOOP	SIZE (FT)	DISTANCE FROM STOPBAR (FT)	TURNS	NEW LOOP	PROGRAMMING							
					PHASE	CALLING	EXTEND TIME	DELAY TIME	USE ADDED INITIAL	TYPE	LOOP SYSTEM	NEW CARD
2A	6X6	100	Exist	-	2	Yes	-	-	-	S	-	X
4A	6X60	+5	2-4-2	-	4	Yes	-	5	-	S	-	X
6A	6X6	100	Exist	-	6	Yes	-	-	-	S	-	X
6B	6X60	+5	2-4-2	-	6	Yes	-	3	-	S	-	X
8A	6X20	+5	Exist	-	8	Yes	-	-	-	S	-	X

2 Phase Fully Actuated (Burlington-Graham Signal System)

NOTES

- Refer to "Roadway Standard Drawings NCDOT" dated January 2018 and "Standard Specifications for Roads and Structures" dated January 2018.
- Do not program signal for late night flashing operation unless otherwise directed by the Engineer.
- Set all detector units to presence mode.
- In the event of loop replacement, refer to the current ITS and Signals Design Manual and submit a Plan of Record to the Signal Design Section.
- Locate new cabinet so as not to obstruct sight distance of vehicles turning right on red.
- The cabinet should be designed to include an Auxiliary Output file for future use.
- Pavement markings are existing.
- Maximum times shown in timing chart are for free-run operation only. Coordinated signal system timing values supersede these values.

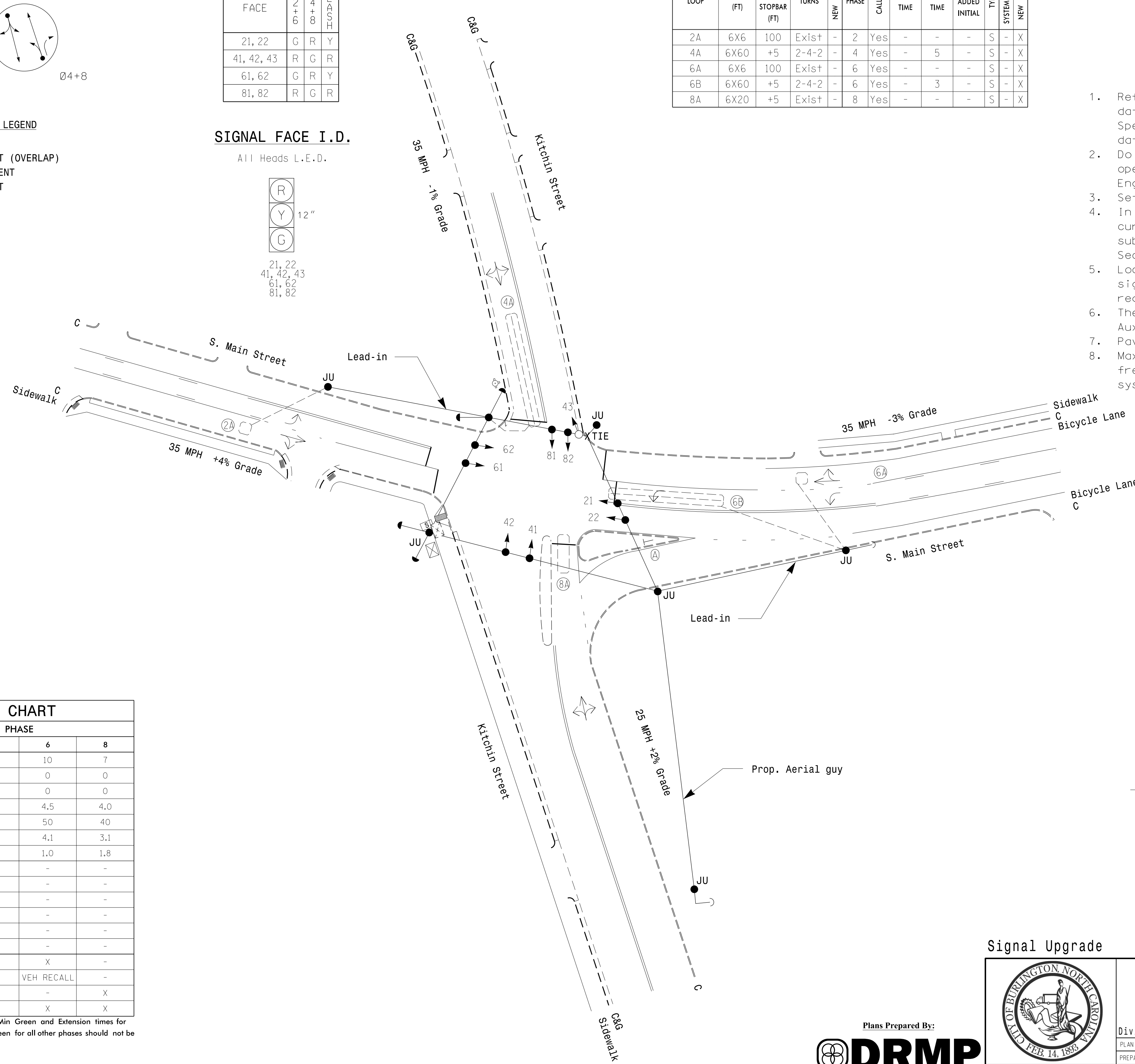

ASC/3 TIMING CHART

FEATURE	PHASE			
	2	4	6	8
Min Green *	10	7	10	7
Walk *	0	0	0	0
Ped Clear	0	0	0	0
Veh. Extension *	4.5	4.0	4.5	4.0
Max 1 *	50	40	50	40
Yellow	3.6	3.9	4.1	3.1
Red Clear	1.8	1.0	1.0	1.8
Actuations B4 Add *	-	-	-	-
Seconds /Actuation *	-	-	-	-
Max Initial *	-	-	-	-
Time Before Reduction *	-	-	-	-
Time To Reduce *	-	-	-	-
Minimum Gap	-	-	-	-
Locking Detector	X	-	X	-
Recall Position	VEH RECALL	-	VEH RECALL	-
Dual Entry	-	X	-	X
Simultaneous Gap	X	X	X	X

* These values may be field adjusted. Do not adjust Min Green and Extension times for phases 2 and 6 lower than what is shown. Min Green for all other phases should not be lower than 4 seconds.

LEGEND

- | PROPOSED | EXISTING |
|--|-----------------------------------|
| ○ → Traffic Signal Head | ● → Traffic Signal Head |
| ○ → Modified Signal Head | N/A |
| ○ → Sign | N/A |
| ○ → Pedestrian Signal Head With Push Button & Sign | ● → Pedestrian Signal Head |
| ○ → Signal Pole with Guy | ● → Signal Pole with Guy |
| ○ → Signal Pole with Sidewalk Guy | ● → Signal Pole with Sidewalk Guy |
| □ → Inductive Loop Detector | □ → Inductive Loop Detector |
| □ → Controller & Cabinet | □ → Controller & Cabinet |
| □ → Junction Box | □ → Junction Box |
| --- 2-in Underground Conduit | --- 2-in Underground Conduit |
| N/A | --- Right of Way |
| → Directional Arrow | → Directional Arrow |
| [S] Terminal Splice Box | [S] Terminal Splice Box |
| N/A | ♿ Wheelchair Ramp |
| N/A | ⚡ Fire Hydrant |
| (A) Yield Sign | (A) Yield Sign |

Signal Upgrade

S. Main Street at Kitchin Street

Division 7 Alamance County Burlington

PLAN DATE: December 2017 REVIEWED BY: AJ Davis

PREPARED BY: J Le REVIEWED BY: LM Moon

REVISIONS: _____ INIT. DATE

DocuSign by: **Lisa M. Moon** 6/13/2018

SIGNATURE: _____ DATE: _____

SIG. INVENTORY NO. B0008

Plans Prepared By:

DRMP, Inc.
8000 Regency Parkway, Suite 175
Cary, NC 27518
NC License No. C-2213 (919) 650-1038

13-JUN-2018 17:55
 R:\616015\1707\1\caks\gnals\02sig\gnals\02sig.dgn
 KANDERSON AT CHA-Y-ANDERSON

EDI MODEL 2018EClip-NC CONFLICT MONITOR PROGRAMMING DETAIL

(remove jumpers and set switches as shown)

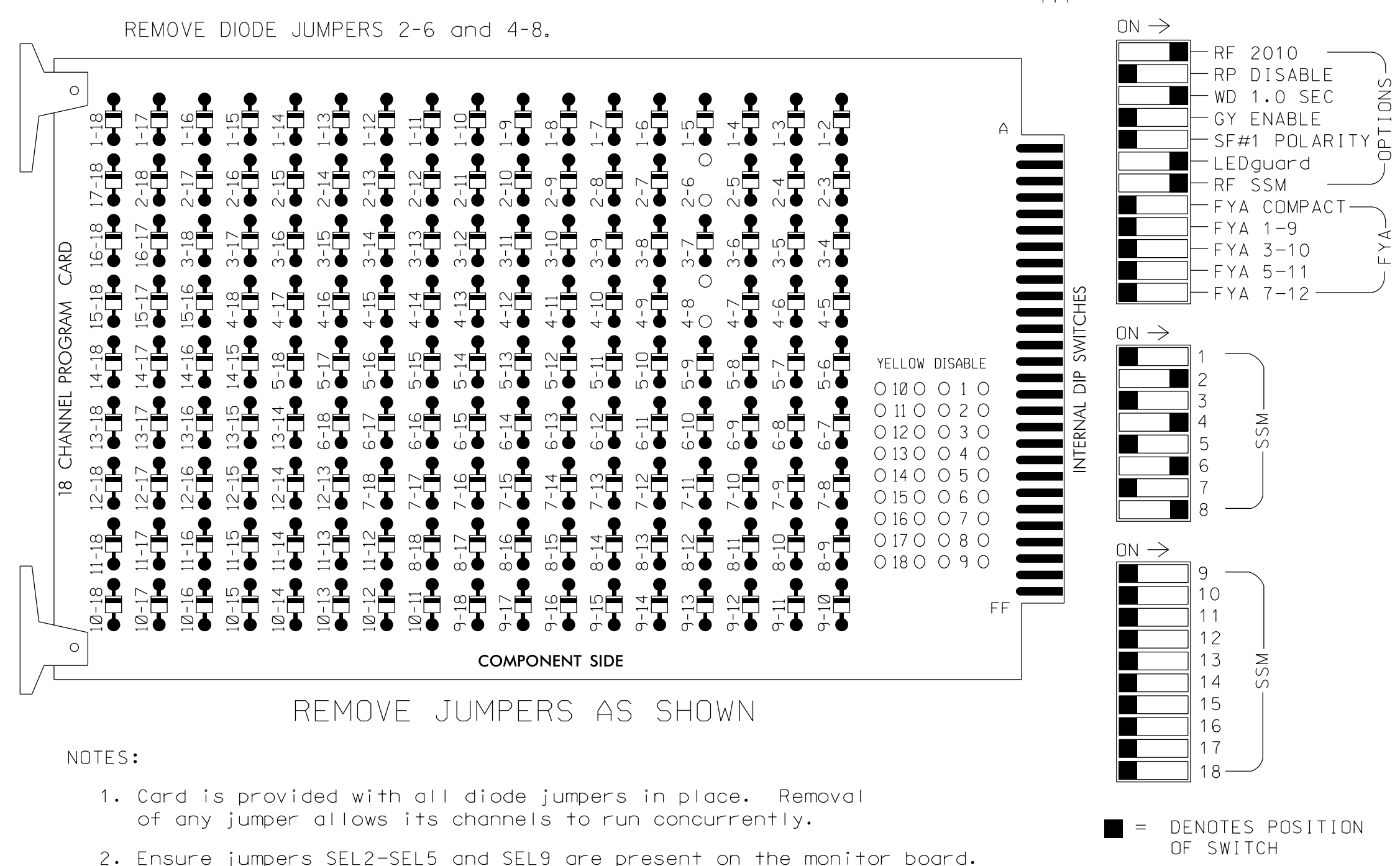

- NOTES:
- Card is provided with all diode jumpers in place. Removal of any jumper allows its channels to run concurrently.
 - Ensure jumpers SEL2-SEL5 and SEL9 are present on the monitor board.
 - Ensure that Red Enable is active at all times during normal operation.
 - Integrate monitor with Ethernet network in cabinet.

NOTES

- To prevent "flash-conflict" problems, insert red flash program blocks for all unused vehicle load switches in the output file. The installer shall verify that signal heads flash in accordance with the Signal Plans.
- Program phases 4 and 8 for Dual Entry.
- Program controller to start up in phase 2 Green and 6 Green.
- The cabinet and controller are part of the Burlington-Graham Signal System.

EQUIPMENT INFORMATION

CONTROLLER.....2070LX
 CABINET.....332 W/AUX
 SOFTWARE.....ECONOLITE ASC/3-2070
 CABINET MOUNT.....BASE
 OUTPUT FILE POSITIONS...18 WITH AUX. OUTPUT FILE
 LOAD SWITCHES USED.....S2,S5,S8,S11
 PHASES USED.....2,4,6,8
 OVERLAP "A".....NOT USED
 OVERLAP "B".....NOT USED
 OVERLAP "C".....NOT USED
 OVERLAP "D".....NOT USED

SIGNAL HEAD HOOK-UP CHART

LOAD SWITCH NO.	S1	S2	S3	S4	S5	S6	S7	S8	S9	S10	S11	S12	AUX S1	AUX S2	AUX S3	AUX S4	AUX S5	AUX S6
CNU CHANNEL NO.	1	2	13	3	4	14	5	6	15	7	8	16	9	10	17	11	12	18
PHASE	1	2	2 PED	3	4	4 PED	5	6	6 PED	7	8	8 PED	OLA	OLB	SPARE	OLC	OLD	SPARE
SIGNAL HEAD NO.	NU	21,22	NU	NU	41,42 43	NU	NU	61,62	NU	NU	81,82	NU	NU	NU	NU	NU	NU	NU
RED		128			101			134			107							
YELLOW		129			102			135			108							
GREEN		130			103			136			109							
RED ARROW																		
YELLOW ARROW																		
GREEN ARROW																		

NU = Not Used

INPUT FILE POSITION LAYOUT

(front view)

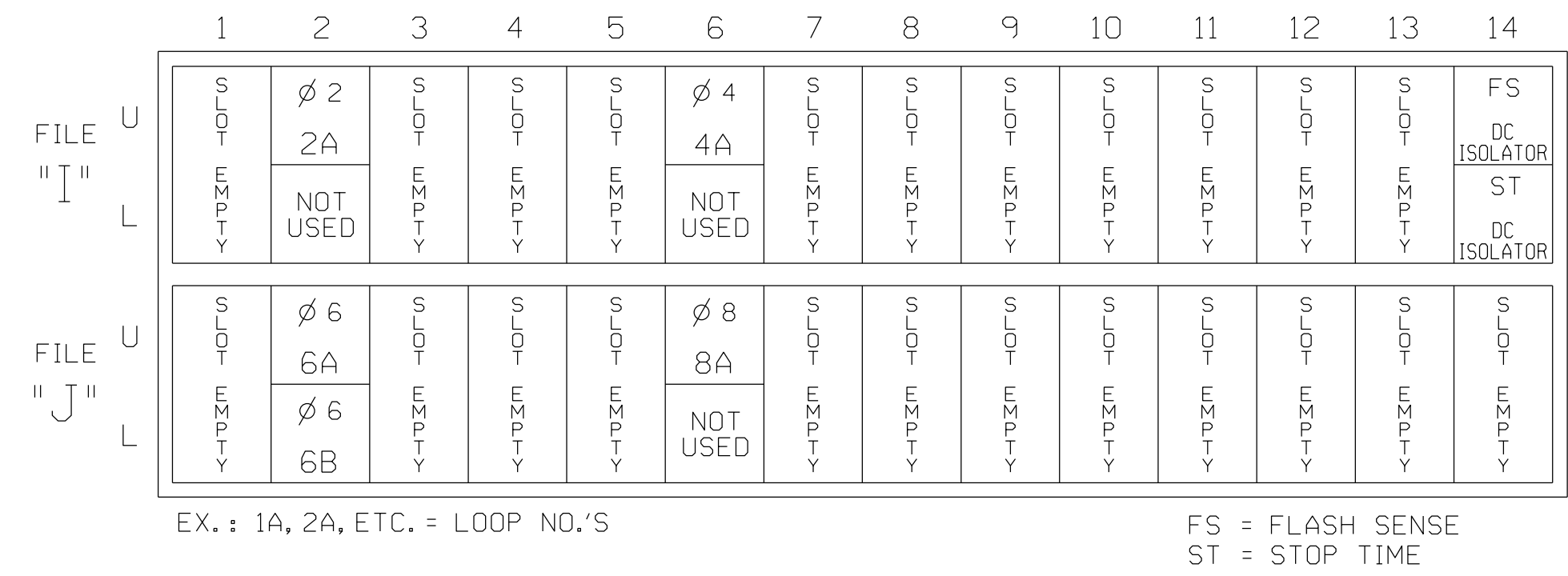

INPUT FILE CONNECTION & PROGRAMMING CHART

LOOP NO.	LOOP TERMINAL	INPUT FILE POS.	PIN NO.	DETECTOR NO.	NEMA PHASE	CALL	EXTEND TIME	DELAY TIME	ADDED INITIAL	DETECTOR TYPE
2A	TB2-5,6	I2U	39	2	2	YES				S
4A	TB4-9,10	I6U	41	4	4	YES		5		S
6A	TB3-5,6	J2U	40	6	6	YES				S
6B	TB3-7,8	J2L	44	16	6	YES		3		S
8A	TB5-9,10	J6U	42	8	8	YES				S

INPUT FILE POSITION LEGEND: J2L
 FILE J
 SLOT 2
 LOWER

THIS ELECTRICAL DETAIL IS FOR THE SIGNAL DESIGN: B0008
 DESIGNED: DECEMBER 2017
 SEALED: 06-13-2018
 REVISED: N/A

Electrical Detail

ELECTRICAL AND PROGRAMMING DETAILS FOR:



S. Main Street
 at
 Kitchin Street

Division 7 Alamance County Burlington

PLAN DATE: December 2017 REVIEWED BY: AJ Davis

PREPARED BY: DJ White REVIEWED BY: LM Moon

REVISIONS	INIT.	DATE



DOCUMENT NOT CONSIDERED FINAL UNLESS ALL SIGNATURES COMPLETED



DocuSigned by: Lisa M. Moon 6/13/2018
 DATE: 6/13/2018
 SIG. INVENTORY NO. B0008

EDI MODEL 2018ECLip-NC CONFLICT MONITOR PROGRAMMING DETAIL

(remove jumpers and set switches as shown)

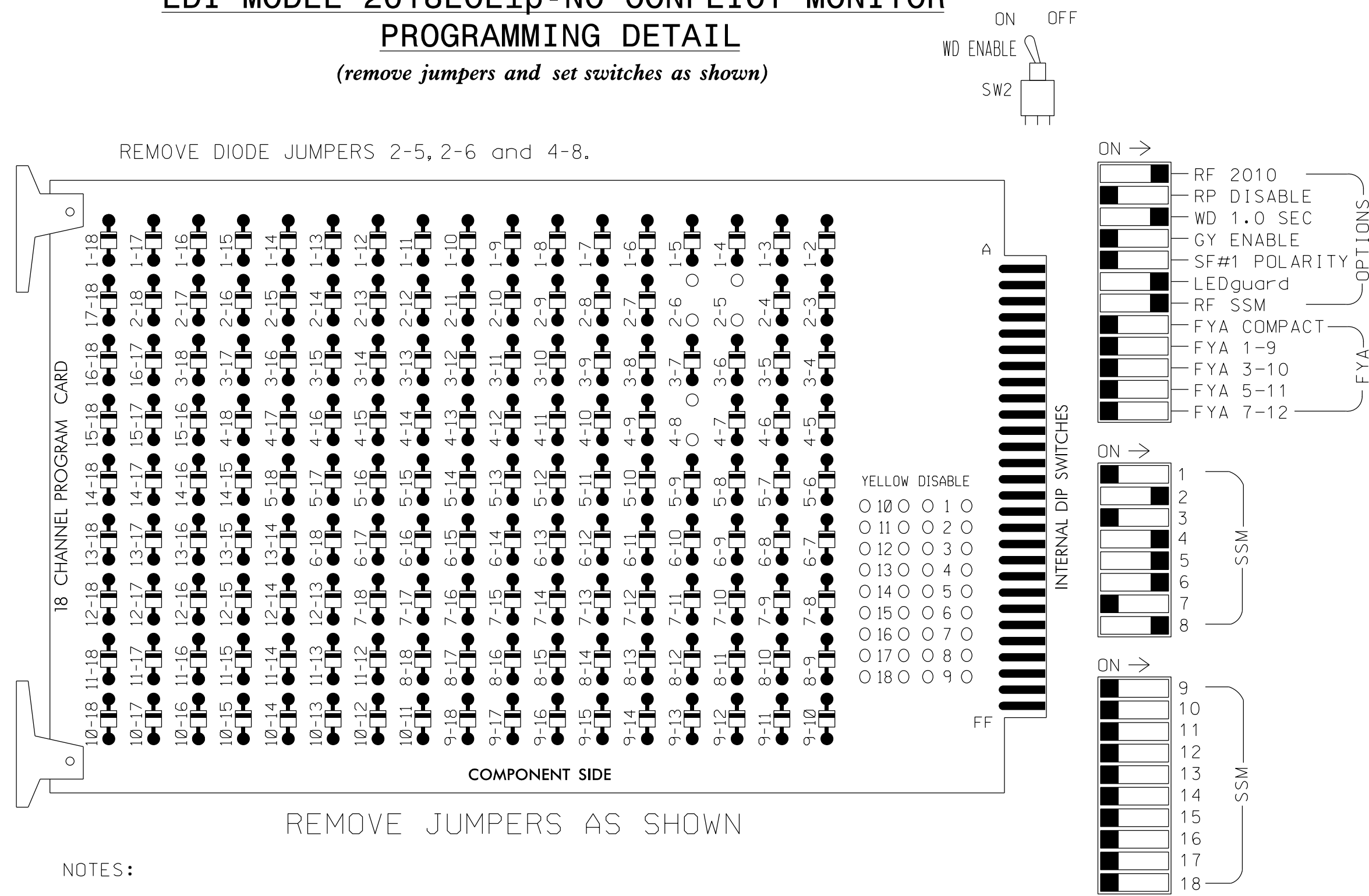

NOTES:

1. Card is provided with all diode jumpers in place. Removal of any jumper allows its channels to run concurrently.
2. Ensure jumpers SEL2-SEL5 and SEL9 are present on the monitor board.
3. Ensure that Red Enable is active at all times during normal operation.
4. Integrate monitor with Ethernet network in cabinet.

NOTES

1. To prevent "flash-conflict" problems, insert red flash program blocks for all unused vehicle load switches in the output file. The installer shall verify that signal heads flash in accordance with the Signal Plans.
2. Program phases 4 and 8 for Dual Entry.
3. Program controller to start up in phase 2 Green and 6 Green.
4. The cabinet and controller are part of the Burlington-Graham Signal System.

EQUIPMENT INFORMATION

CONTROLLER.....2070LX
 CABINET.....332 W/AUX
 SOFTWARE.....ECONOLITE ASC/3-2070
 CABINET MOUNT.....BASE
 OUTPUT FILE POSITIONS...18 WITH AUX. OUTPUT FILE
 LOAD SWITCHES USED.....S2,S5,S7,S8,S11
 PHASES USED.....2,4,5,6,8
 OVERLAP "A".....NOT USED
 OVERLAP "B".....NOT USED
 OVERLAP "C".....NOT USED
 OVERLAP "D".....NOT USED

SIGNAL HEAD HOOK-UP CHART

LOAD SWITCH NO.	S1	S2	S3	S4	S5	S6	S7	S8	S9	S10	S11	S12	AUX S1	AUX S2	AUX S3	AUX S4	AUX S5	AUX S6
CMU CHANNEL NO.	1	2	13	3	4	14	5	6	15	7	8	16	9	10	17	11	12	18
PHASE	1	2	2 PED	3	4	4 PED	5	6	6 PED	7	8	8 PED	OLA	OLB	SPARE	OLC	OLD	SPARE
SIGNAL HEAD NO.	NU	21,22	NU	NU	41,42	NU	21	61,62	NU	NU	81,82	NU	NU	NU	NU	NU	NU	NU
RED		128			101		*	134			107							
YELLOW		129			102			135			108							
GREEN		130			103			136			109							
RED ARROW																		
YELLOW ARROW								132										
GREEN ARROW								133										

NU = Not Used

* Denotes install load resistor. See load resistor installation detail this sheet.

INPUT FILE POSITION LAYOUT

(front view)

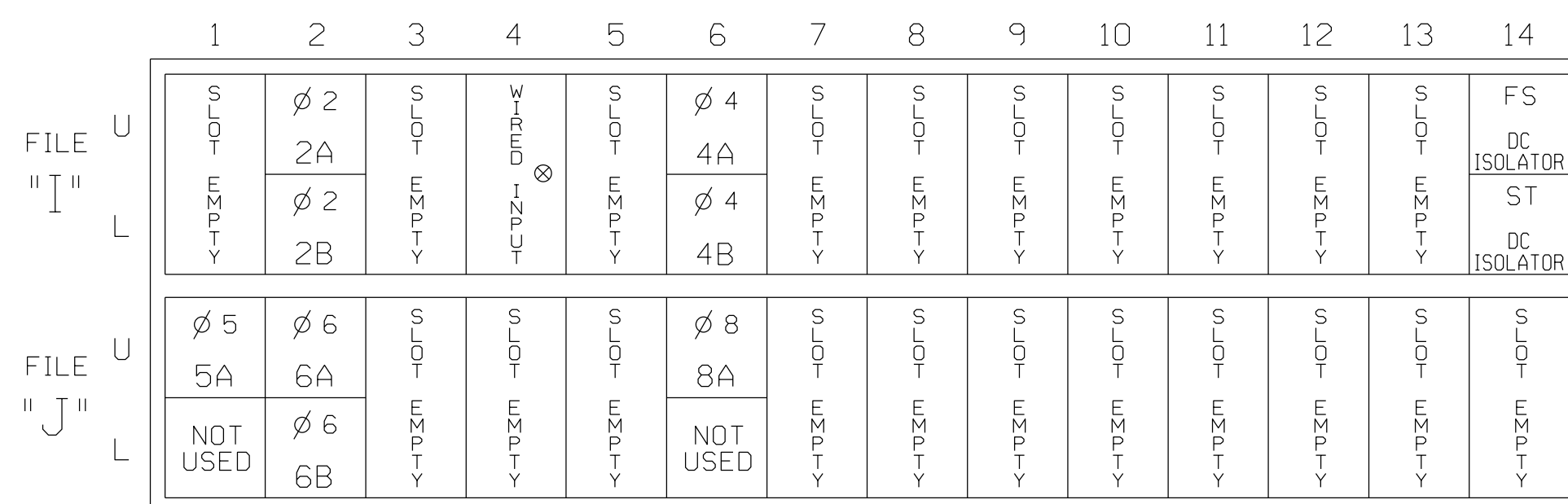

EX.: 1A, 2A, ETC. = LOOP NO.'S

FS = FLASH SENSE
 ST = STOP TIME

INPUT FILE CONNECTION & PROGRAMMING CHART

LOOP NO.	LOOP TERMINAL	INPUT FILE POS.	PIN NO.	DETECTOR NO.	NEMA PHASE	CALL	EXTEND TIME	DELAY TIME	USE ADDED INITIAL	DETECTOR TYPE
2A	TB2-5,6	I2U	39	2	2	YES			-	S
2B	TB2-7,8	I2L	43	12	2	YES			-	S
4A	TB4-9,10	I6U	41	4	4	YES			-	S
4B	TB4-11,12	I6L	45	14	4	YES		10	-	S
5A ¹	TB3-1,2	J1U	55	5	5	YES		15	-	S
		14U	47	22	2	YES		3	-	S
6A	TB3-5,6	J2U	40	6	6	YES			-	S
6B	TB3-7,8	J2L	44	16	6	YES			-	S
8A	TB5-9,10	J6U	42	8	8	YES		10	-	S

¹Add jumper from J1-W to 14-W, on rear of input file.

INPUT FILE POSITION LEGEND: J2L

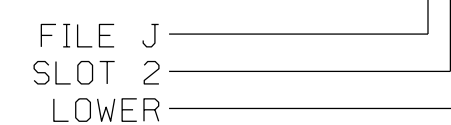

LOAD RESISTOR INSTALLATION DETAIL

ACCEPTABLE VALUES

VALUE (ohms)	WATTAGE
1.5K - 1.9K	25W (min)
2.0K - 3.0K	10W (min)

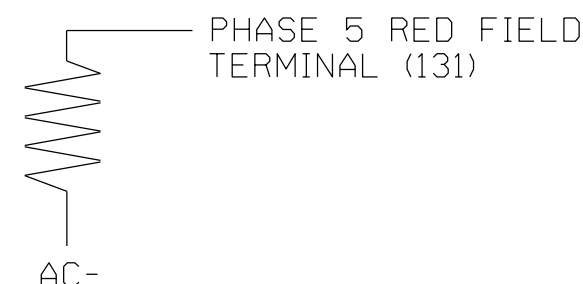

NOTE: The purpose of these resistors is to load the channel red monitor inputs in order for the Signal Sequence Monitor to use the full signal sequence monitoring capability on channels that do not use the red display in the field.

Electrical Detail - Sheet 1 of 2

DOCUMENT NOT CONSIDERED FINAL UNLESS ALL SIGNATURES COMPLETED

ELECTRICAL AND PROGRAMMING DETAILS FOR:

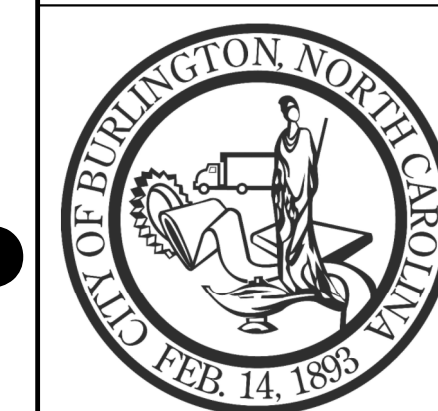

N. Mebane Street at Ireland Street	
Division 7	Alamance County
PLAN DATE: November 2017	REVIEWED BY: AJ Davis
PREPARED BY: DJ White	REVIEWED BY: LM Moon
REVISIONS	INIT. DATE

SEAL
 NORTH CAROLINA PROFESSIONAL ENGINEER
 SEAL 022516
 LISA M. MOON
 DocuSigned by: Lisa M. Moon 6/13/2018
 DATE
 S.I.G. INVENTORY NO. B0011

**ECONOLITE ASC/3-2070 BACKUP
PROTECTION ENABLE PROGRAMMING**
(program controller as shown)

- From Main Menu select 1. CONFIGURATION
- From CONFIGURATION Submenu select 1. CONTROLLER SEQ
- From CONTROLLER SEQUENCE Submenu select 3. BACKUP PREVENT PHASES

Follow programming as shown below. On the 'ENABLE BACKUP PREVENT' screen move cursor to the appropriate field and press 'YES/NO' on the controller keypad to toggle field value between 'X', 'B', 'C' and 'OFF'.

ENABLE BACKUP PREVENT																
TMG/BKUP	1	2	3	4	5	6	7	8	9	0	1	2	3	4	5	6
1
2
3
4
5
6	.	.	.	B
7
8
9
10
11
12
13
14
15
16

END PROGRAMMING

NOTE

- 'B' without a 'C' programmed for the 'TIMING' (row) phase inhibits the controller from servicing the 'BACKUP' (column) phase when the 'TIMING' (row) phase is active, or next, until the controller goes through Red Revert and Red Clear. Make sure the proper Red Revert and Red Clear times shown on the Signal Design plan are programmed in the controller phase timing.

THIS ELECTRICAL DETAIL IS FOR
THE SIGNAL DESIGN: B0011
DESIGNED: NOVEMBER 2017
SEALED: 06-13-2018
REVISED: N/A

13-JUN-2018 17:57
 R:\66015\Prof\esign\esign\wiring\B0011e.dgn
 KANDERSON AT CHA-KANDERSON

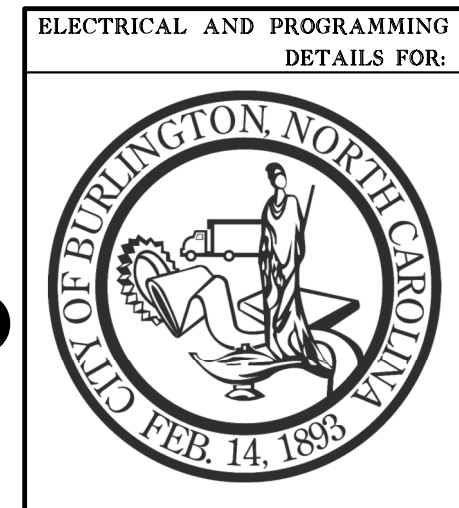
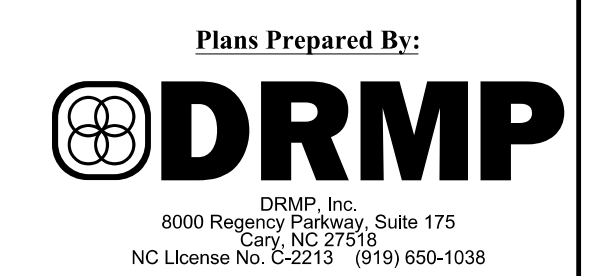

N. Mebane Street at Ireland Street	
Division 7	Alamance County Burlington
PLAN DATE: November 2017	REVIEWED BY: AJ Davis
PREPARED BY: DJ White	REVIEWED BY: LM Moon
REVISIONS	INIT. DATE

SEAL

DocuSigned by:
Lisa M. Moon 6/13/2018
DATE
SIG. INVENTORY NO. B0011

PHASING DIAGRAM

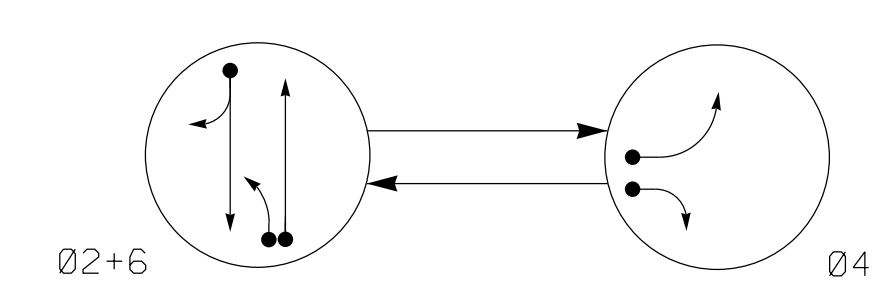

PHASING DIAGRAM DETECTION LEGEND

- → DETECTED MOVEMENT
- → UNDETECTED MOVEMENT (OVERLAP)
- → UNSIGNALIZED MOVEMENT
- ⇄ → PEDESTRIAN MOVEMENT

TABLE OF OPERATION

SIGNAL FACE	PHASE		
	Ø 2+6	Ø 4	FLASH
21, 22, 23	G	R	Y
41, 42	R	G	R
61, 62	G	R	Y

SIGNAL FACE I.D.

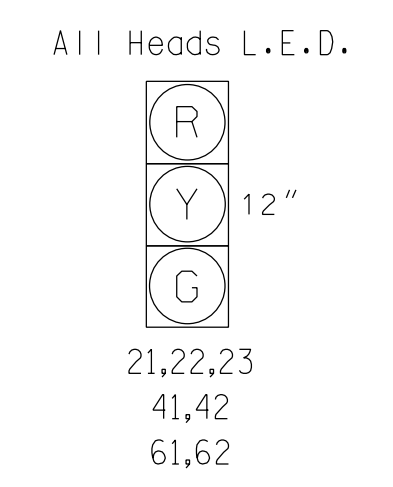

ASC/3 DETECTOR INSTALLATION CHART

LOOP	SIZE (FT)	DISTANCE FROM STOPBAR (FT)	TURNS	PROGRAMMING									
				NEW LOOP	PHASE	CALLING	EXTEND TIME	DELAY TIME	USE ADDED INITIAL	TYPE	SYSTEM LOOP	NEW CARD	
2A	6X6	70	EXIST	-	2	Yes	-	-	-	-	S	-	X
2B	6X40	0	2-4-2	-	2	Yes	-	-	-	-	S	-	X
4A	6X40	0	2-4-2	-	4	Yes	-	3	-	-	S	-	X
4B	6X40	0	2-4-2	-	4	Yes	-	15	-	-	S	-	X
6A	6X6	70	EXIST	-	6	Yes	-	-	-	-	S	-	X

2 Phase Fully Actuated (Burlington-Graham Signal System)

NOTES

- Refer to "Roadway Standard Drawings NCDOT" dated January 2018 and "Standard Specifications for Roads and Structures" dated January 2018.
- Do not program signal for late night flashing operation unless otherwise directed by the Engineer.
- Reposition existing signal head number 21.
- Set all detector units to presence mode.
- Locate new cabinet so as not to obstruct sight distance of vehicles turning right on red.
- Pavement markings are existing.
- Maximum times shown in timing chart are for free-run operation only. Coordinated signal system timing values supersede these values.

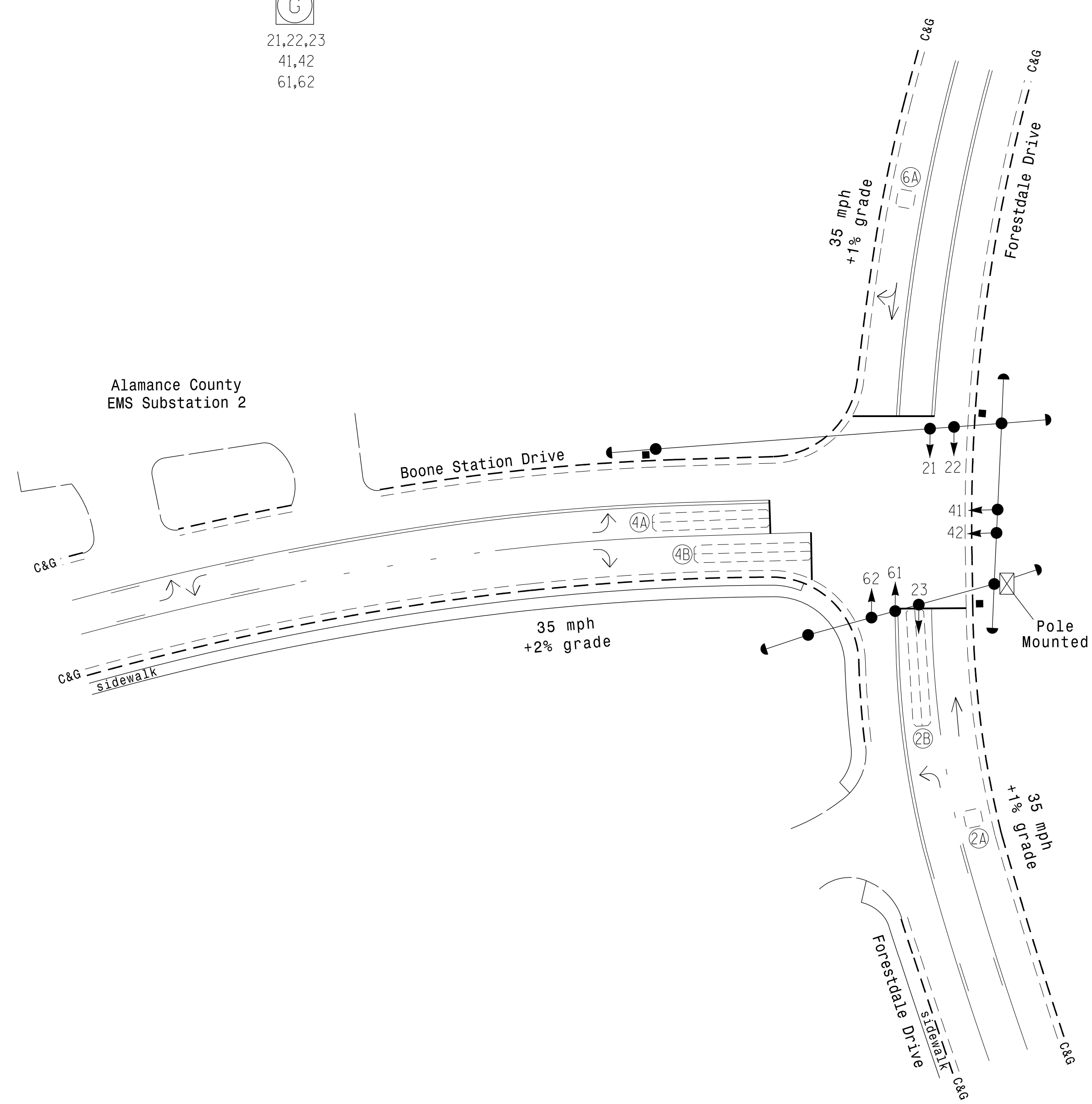

ASC/3 TIMING CHART

FEATURE	PHASE		
	2	4	6
Min Green *	10	7	10
Walk *	0	0	0
Ped Clear	0	0	0
Veh. Extension *	3.0	2.0	3.0
Max 1 *	50	20	50
Yellow	3.8	3.0	3.8
Red Clear	1.1	2.1	1.1
Actuations B4 Add *	-	-	-
Seconds / Actuation *	-	-	-
Max Initial *	-	-	-
Time Before Reduction *	-	-	-
Time To Reduce *	-	-	-
Minimum Gap	-	-	-
Locking Detector	X	-	X
Recall Position	VEH. RECALL	-	VEH. RECALL
Dual Entry	-	-	-
Simultaneous Gap	X	X	X

* These values may be field adjusted. Do not adjust Min Green and Extension times for phases 2 and 6 lower than what is shown. Min Green for all other phases should not be lower than 4 seconds.

LEGEND

PROPOSED	EXISTING
○ → Traffic Signal Head	● → Traffic Signal Head
○ → Modified Signal Head	N/A
⊥ Sign	⊥ Sign
⊥ Pedestrian Signal Head With Push Button & Sign	⊥ Pedestrian Signal Head With Push Button & Sign
○ ⊥ Signal Pole with Guy	○ ⊥ Signal Pole with Guy
⊥ Signal Pole with Sidewalk Guy	⊥ Signal Pole with Sidewalk Guy
⊠ Inductive Loop Detector	⊠ Inductive Loop Detector
⊠ Controller & Cabinet	⊠ Controller & Cabinet
□ Junction Box	□ Junction Box
--- 2-in Underground Conduit	--- 2-in Underground Conduit
N/A Right of Way	--- Right of Way
→ Directional Arrow	→ Directional Arrow

Signal Upgrade

DOCUMENT NOT CONSIDERED FINAL UNLESS ALL SIGNATURES COMPLETED

	Forestdale Drive at Boone Station Drive		
	Division 7 Alamance County Burlington		
PLAN DATE: November 2017	REVIEWED BY: AM Encarnacion		DATE: 6/7/2018
PREPARED BY: JA Wiles	REVIEWED BY: PL Alexander		
REVISIONS	INIT.	DATE	SIGNATURE: Pamela Alexander
			SIG. INVENTORY NO. B-0012

ATKINS 1616 EAST MILLBROOK ROAD, SUITE 160 RALEIGH, NORTH CAROLINA 27609 (919) 876-6888 NCBES #F-0326

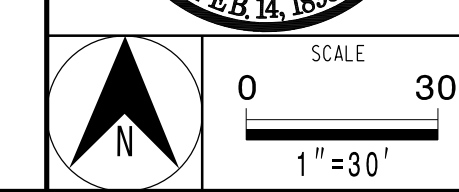

07-JUN-2018 11:15 D:\Transpor\atkins\Traffic\c\cur\100056469 U-6015 B-G S19 Sys\Task 05_11_Signal\Doc\gmmf-0012.dgn ALEX3361 AT LUS210649

EDI MODEL 2018ECLip-NC CONFLICT MONITOR PROGRAMMING DETAIL

(remove jumper and set switches as shown)

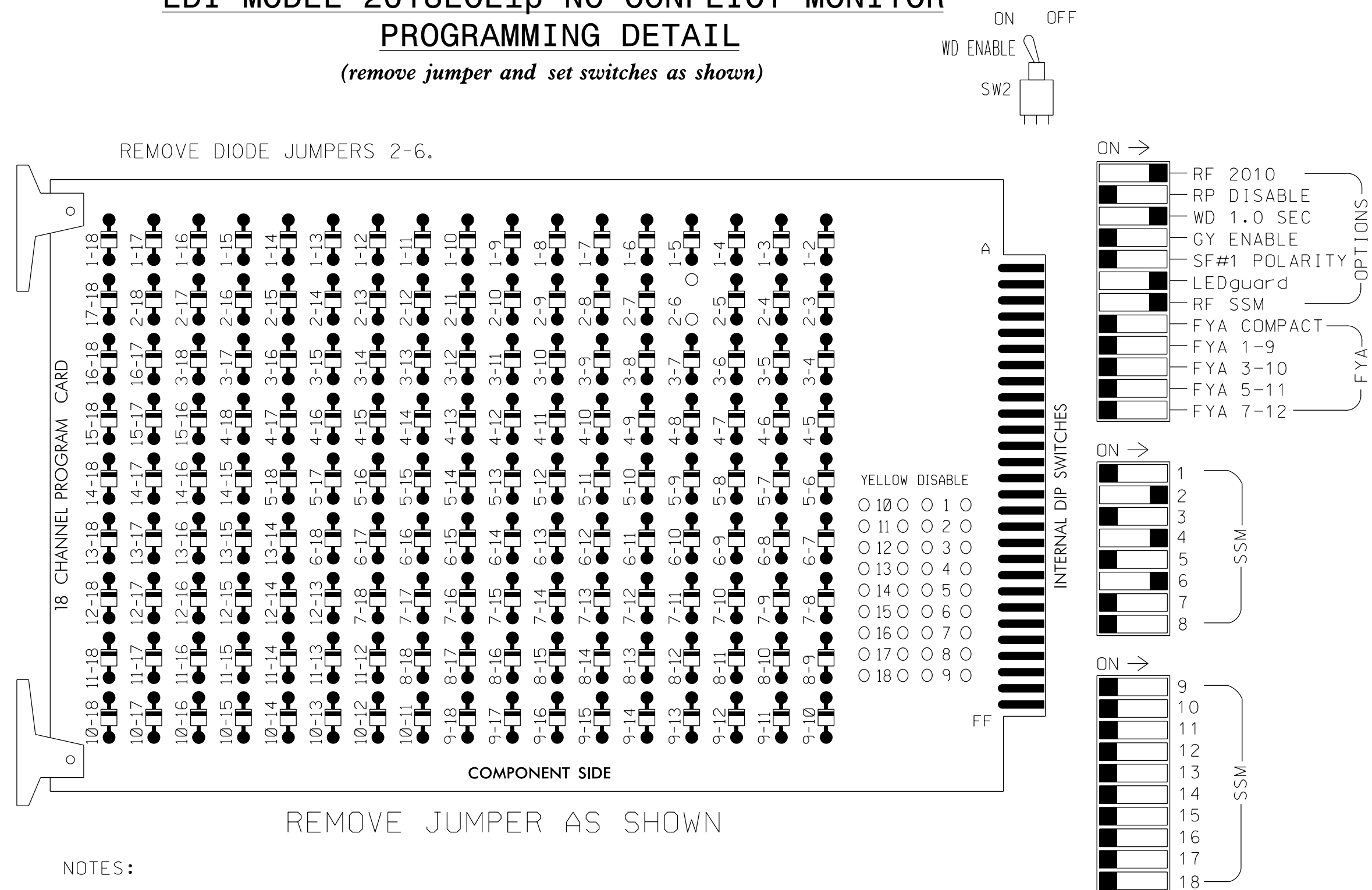

NOTES:

1. Card is provided with all diode jumpers in place. Removal of any jumper allows its channels to run concurrently.
2. Ensure jumpers SEL2-SEL5 and SEL9 are present on the monitor board.
3. Ensure that Red Enable is active at all times during normal operation.
4. Integrate monitor with Ethernet network in cabinet.

NOTES

1. To prevent "flash-conflict" problems, insert red flash program blocks for all unused vehicle load switches in the output file. The installer shall verify that signal heads flash in accordance with the Signal Plans.
2. Program controller to start up in phase 2 Green and 6 Green.
3. The cabinet and controller are part of the Burlington-Graham Signal System.

EQUIPMENT INFORMATION

CONTROLLER.....2070LX
 CABINET.....336
 SOFTWARE.....ECONOLITE ASC/3-2070
 CABINET MOUNT.....POLE
 OUTPUT FILE POSITIONS...12
 LOAD SWITCHES USED.....S2,S5,S8
 PHASES USED.....2,4,6
 OVERLAPS.....NONE

SIGNAL HEAD HOOK-UP CHART

LOAD SWITCH NO.	S1	S2	S3	S4	S5	S6	S7	S8	S9	S10	S11	S12
CMU CHANNEL NO.	1	2	13	3	4	14	5	6	15	7	8	16
PHASE	1	2	2 PED	3	4	4 PED	5	6	6 PED	7	8	8 PED
SIGNAL HEAD NO.	NU	21,22,23	NU	NU	41,42	NU	NU	61,62	NU	NU	NU	NU
RED		128			101			134				
YELLOW		129			102			135				
GREEN		130			103			136				
RED ARROW												
YELLOW ARROW												
GREEN ARROW												

NU = Not Used

INPUT FILE POSITION LAYOUT

(front view)

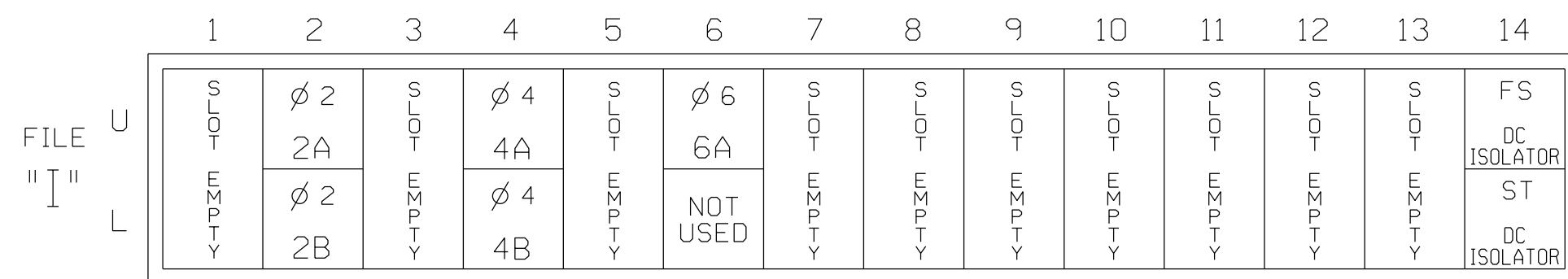

EX. : 1A, 2A, ETC. = LOOP NO.'S

FS = FLASH SENSE
 ST = STOP TIME

INPUT FILE CONNECTION & PROGRAMMING CHART

LOOP NO.	LOOP TERMINAL	INPUT FILE POS.	PIN NO.	DETECTOR NO.	NEMA PHASE	CALL	EXTEND TIME	DELAY TIME	ADDED INITIAL	DETECTOR TYPE
2A	TB21-3,4	I2U	39	2	2	YES				S
2B	TB23-3,4	I2L	43	12	2	YES				S
4A	TB21-7,8	I4U	41	4	4	YES		3		S
4B	TB23-7,8	I4L	45	14	4	YES		15		S
6A	TB21-11,12	I6U	40	6	6	YES				S

INPUT FILE POSITION LEGEND: J2L

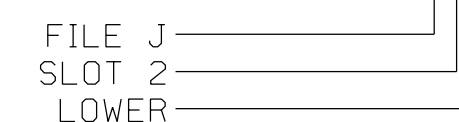

THIS ELECTRICAL DETAIL IS FOR THE SIGNAL DESIGN: B-0012
 DESIGNED: November 2017
 SEALED: 6/7/2018
 REVISED: N/A

Electrical Detail

ELECTRICAL AND PROGRAMMING DETAILS FOR:

Prepared for the Offices of:



Forestdale Drive
 at
 Boone Station Drive

Division 7 Alamance County Burlington
 PLAN DATE: November 2017 REVIEWED BY: AM Encarnacion
 PREPARED BY: JA Wiles REVIEWED BY: PL Alexander

REVISIONS	INIT.	DATE

DOCUMENT NOT CONSIDERED FINAL UNLESS ALL SIGNATURES COMPLETED

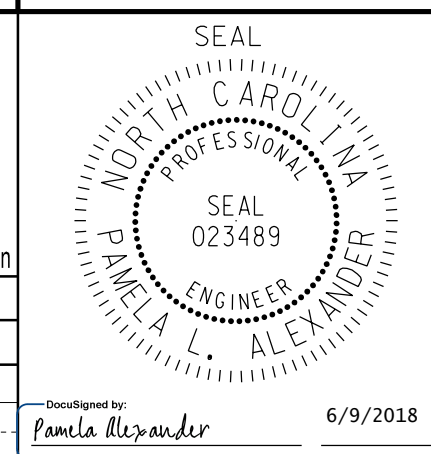

SIG. INVENTORY NO. B-0012

ATKINS 1616 EAST MILLBROOK ROAD, SUITE 160
 RALEIGH, NORTH CAROLINA 27609
 (919) 876-6888 NCBEE #F-0326

PHASING DIAGRAM

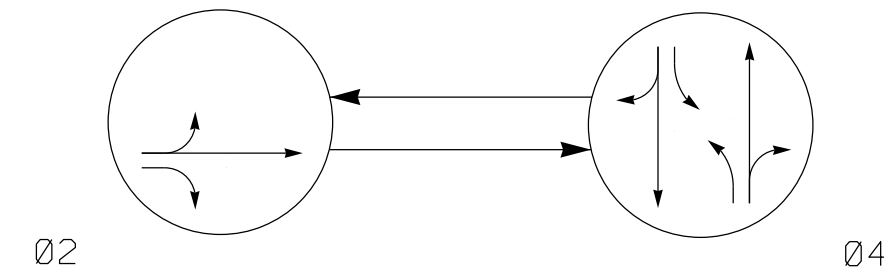

- PHASING DIAGRAM DETECTION LEGEND**
- ← DETECTED MOVEMENT
 - ← UNDETECTED MOVEMENT (OVERLAP)
 - ← UNSIGNALIZED MOVEMENT
 - ⋯ ← PEDESTRIAN MOVEMENT

TABLE OF OPERATION

SIGNAL FACE	PHASE		
	Ø 2	Ø 4	FLASH
21, 22	G	R	Y
41, 42	R	G	R
43, 44	R	G	R

SIGNAL FACE I.D.

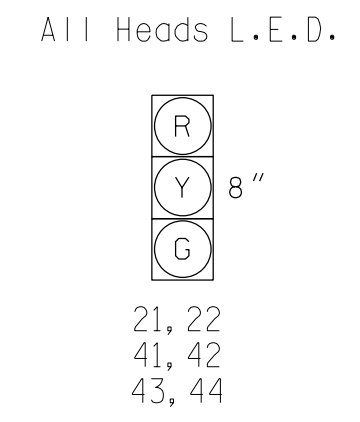

ASC/3 DETECTOR INSTALLATION CHART

LOOP	SIZE (FT)	DISTANCE FROM STOPBAR (FT)	TURNS	NEW LOOP	PROGRAMMING							
					PHASE	CALLING	EXTEND TIME	DELAY TIME	USE ADDED INITIAL	TYPE	SYSTEM LOOP	NEW CARD
S1	6X6	* +25	3	X	-	No	-	-	-	N	X	X

*Distance is measured from nearest crosswalk

2 Phase Pretimed
(Burlington-Graham Signal System)

NOTES

1. Refer to "Roadway Standard Drawings NCDOT" dated January 2018 and "Standard Specifications for Roads and Structures" dated January 2018.
2. Do not program signal for late night flashing operation unless otherwise directed by the Engineer.
3. Locate new cabinet so as not to obstruct sight distance of vehicles turning right on red.
4. Pavement markings are existing.
5. Free-run times shown in timing chart are for free-run operation only. Coordinated signal system timing values supersede these values.

ASC/3 TIMING CHART

FEATURE	PHASE	
	2	4
Min Green *	10	7
Walk *	0	0
Ped Clear	0	0
Veh. Extension *	0.0	0.0
Max 1 *	46	22
Yellow	3.0	3.0
Red Clear	2.6	2.1
Actuations B4 Add *	-	-
Seconds / Actuation *	-	-
Max Initial *	-	-
Time Before Reduction *	-	-
Time To Reduce *	-	-
Minimum Gap	-	-
Locking Detector	-	-
Recall Position	MAX RECALL	MAX RECALL
Dual Entry	-	-
Simultaneous Gap	X	X

* These values may be field adjusted. Do not adjust Min Green and Extension times for phase 2 lower than what is shown. Min Green for all other phases should not be lower than 4 seconds.

LEGEND

PROPOSED	EXISTING

14-JUN-2018 11:38
 R:\66015\179\179.dgn
 DWG:179 AT CAR-DWH\JE-LTW

DRMP
 DRMP, Inc.
 8000 Regency Parkway, Suite 175
 Cary, NC 27518
 NC License No. C-2213 (919) 650-1038

Signal Upgrade

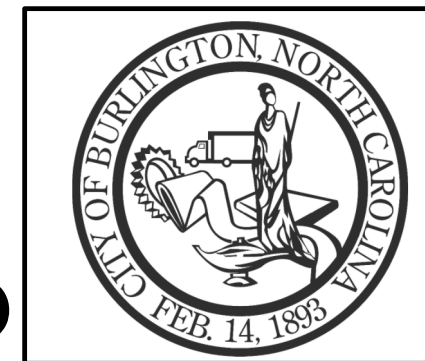

S. Main Street at Maple Avenue

Division 7 Alamance County Burlington

PLAN DATE: January 2018 REVIEWED BY: AJ Davis

PREPARED BY: J Le REVIEWED BY: LM Moon

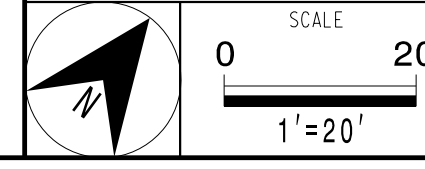
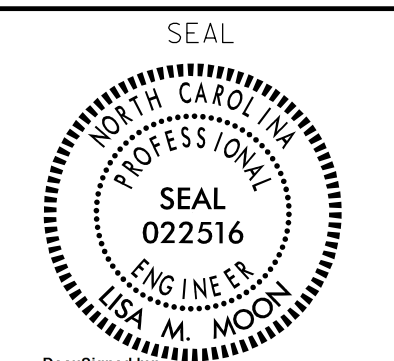

REVISIONS	INIT.	DATE

DocuSigned by:
Lisa M. Moon
 6/14/2018
 SIGNATURE DATE
 SIG. INVENTORY NO. B6228

DOCUMENT NOT CONSIDERED FINAL UNLESS ALL SIGNATURES COMPLETED

EDI MODEL 2018ECLip-NC CONFLICT MONITOR PROGRAMMING DETAIL

(keep jumpers and set switches as shown)

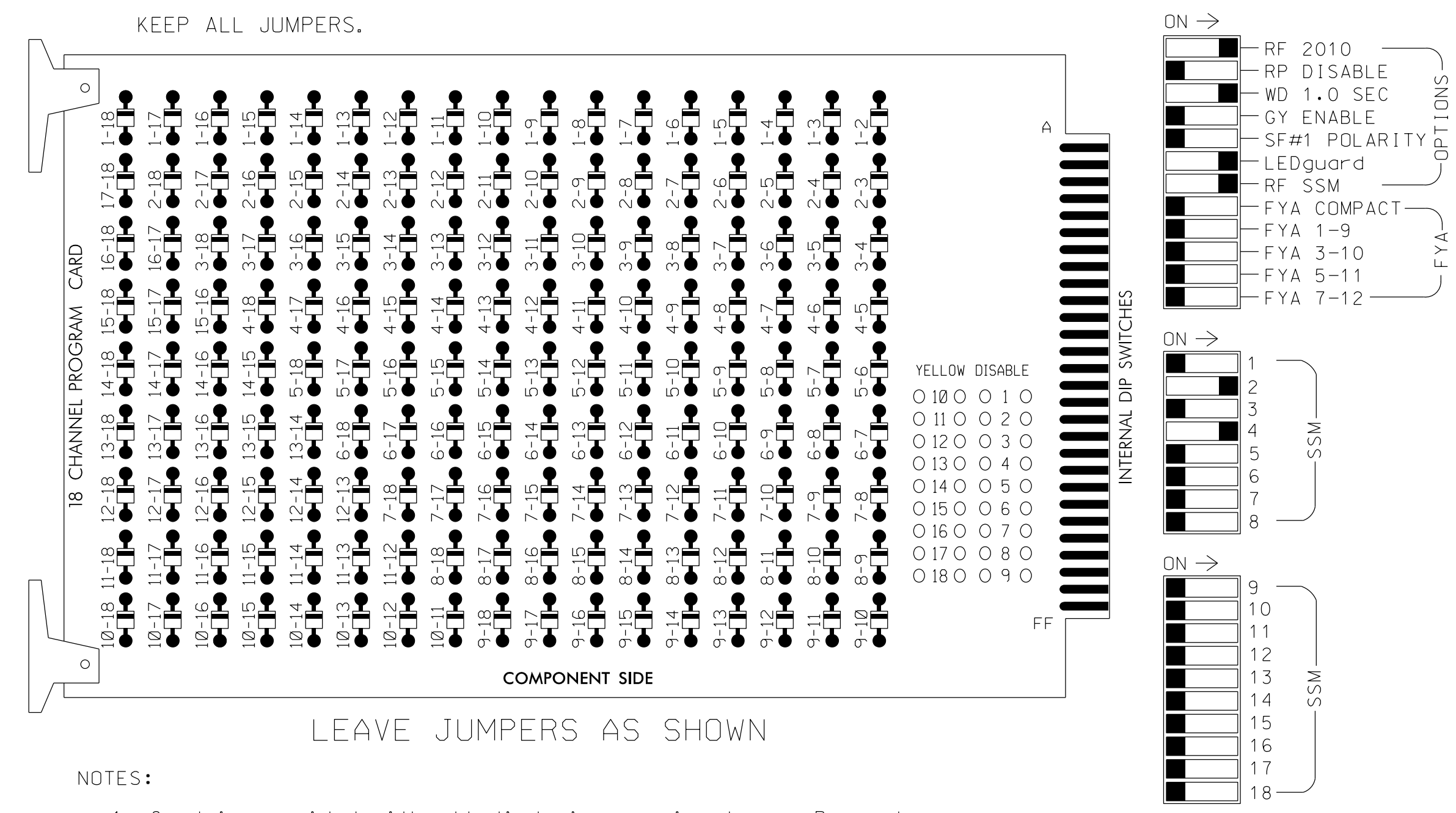

NOTES:

1. Card is provided with all diode jumpers in place. Removal of any jumper allows its channels to run concurrently.
2. Ensure jumpers SEL2-SEL5 and SEL9 are present on the monitor board.
3. Ensure that Red Enable is active at all times during normal operation.
4. Integrate monitor with Ethernet network in cabinet.

NOTES

1. To prevent "flash-conflict" problems, insert red flash program blocks for all unused vehicle load switches in the output file. The installer shall verify that signal heads flash in accordance with the Signal Plans.
2. Program controller to start up in phase 2 Green.
3. Program phase 6 for red flash.
4. The cabinet and controller are part of the Burlington-Graham Signal System.

EQUIPMENT INFORMATION

CONTROLLER.....2070LX
 CABINET.....336
 SOFTWARE.....ECONDLITE ASC/3-2070
 CABINET MOUNT.....BASE
 OUTPUT FILE POSITIONS...12
 LOAD SWITCHES USED.....S2,S5
 PHASES USED.....2,4
 OVERLAPS.....NONE

SIGNAL HEAD HOOK-UP CHART

LOAD SWITCH NO.	S1	S2	S3	S4	S5	S6	S7	S8	S9	S10	S11	S12
CMU CHANNEL NO.	1	2	13	3	4	14	5	6	15	7	8	16
PHASE	1	2	2 PED	3	4	4 PED	5	6	6 PED	7	8	8 PED
SIGNAL HEAD NO.	NU	21,22	NU	NU	41,42 43,44	NU	NU	NU	NU	NU	NU	NU
RED		128			101							
YELLOW		129			102							
GREEN		130			103							
RED ARROW												
YELLOW ARROW												
GREEN ARROW												

NU = Not Used

INPUT FILE POSITION LAYOUT

(front view)

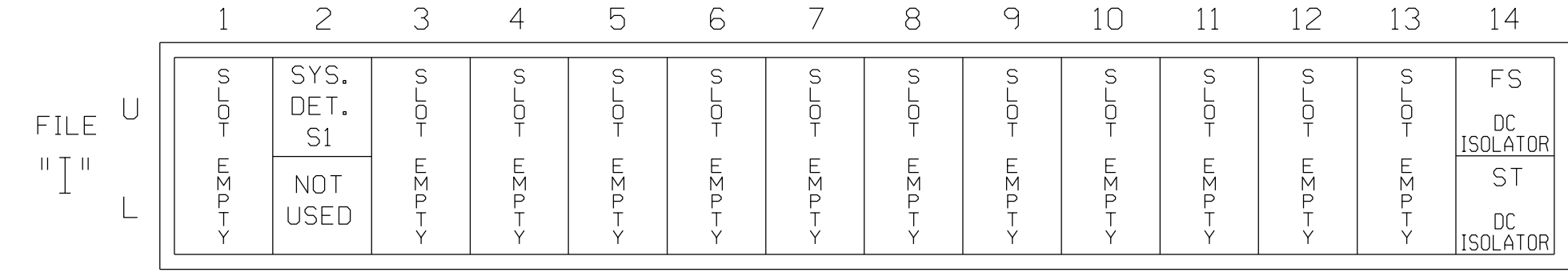

EX. : 1A, 2A, ETC. = LOOP NO.'S

FS = FLASH SENSE
 ST = STOP TIME

INPUT FILE CONNECTION & PROGRAMMING CHART

LOOP NO.	LOOP TERMINAL	INPUT FILE POS.	PIN NO.	DETECTOR NO.	NEMA PHASE	CALL	EXTEND TIME	DELAY TIME	ADDED INITIAL	DETECTOR TYPE
* S1	TB2-5,6	I2U	39	2	SYS	NO				N

* System detector only. Remove any assigned vehicle phase.

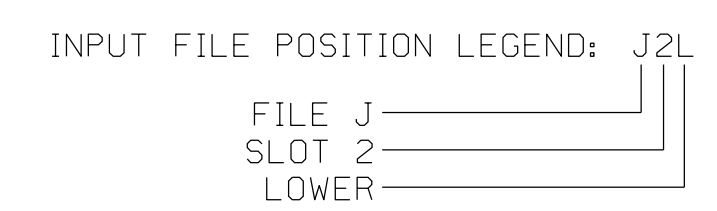

14-Jul-2018 11:40 R:\66015\T\off\c\k\signals\design\wiring\46228a.dgn dwhite AT CAR-DWHITE-LTW

THIS ELECTRICAL DETAIL IS FOR THE SIGNAL DESIGN: B6228
 DESIGNED: JANUARY 2018
 SEALED: 06-14-2018
 REVISED: N/A

Electrical Detail

DOCUMENT NOT CONSIDERED FINAL UNLESS ALL SIGNATURES COMPLETED



S. Main Street at Maple Avenue
 Division 7 Alamance County Burlington
 PLAN DATE: January 2018 REVIEWED BY: AJ Davis
 PREPARED BY: DJ White REVIEWED BY: LM Moon

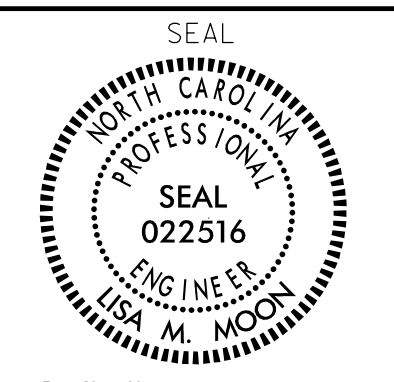

DocuSigned by: Lisa M. Moon 6/14/2018
 DATE: 6/14/2018
 SIG. INVENTORY NO. B6228

EDI MODEL 2018ECLip-NC CONFLICT MONITOR PROGRAMMING DETAIL

(remove jumpers and set switches as shown)

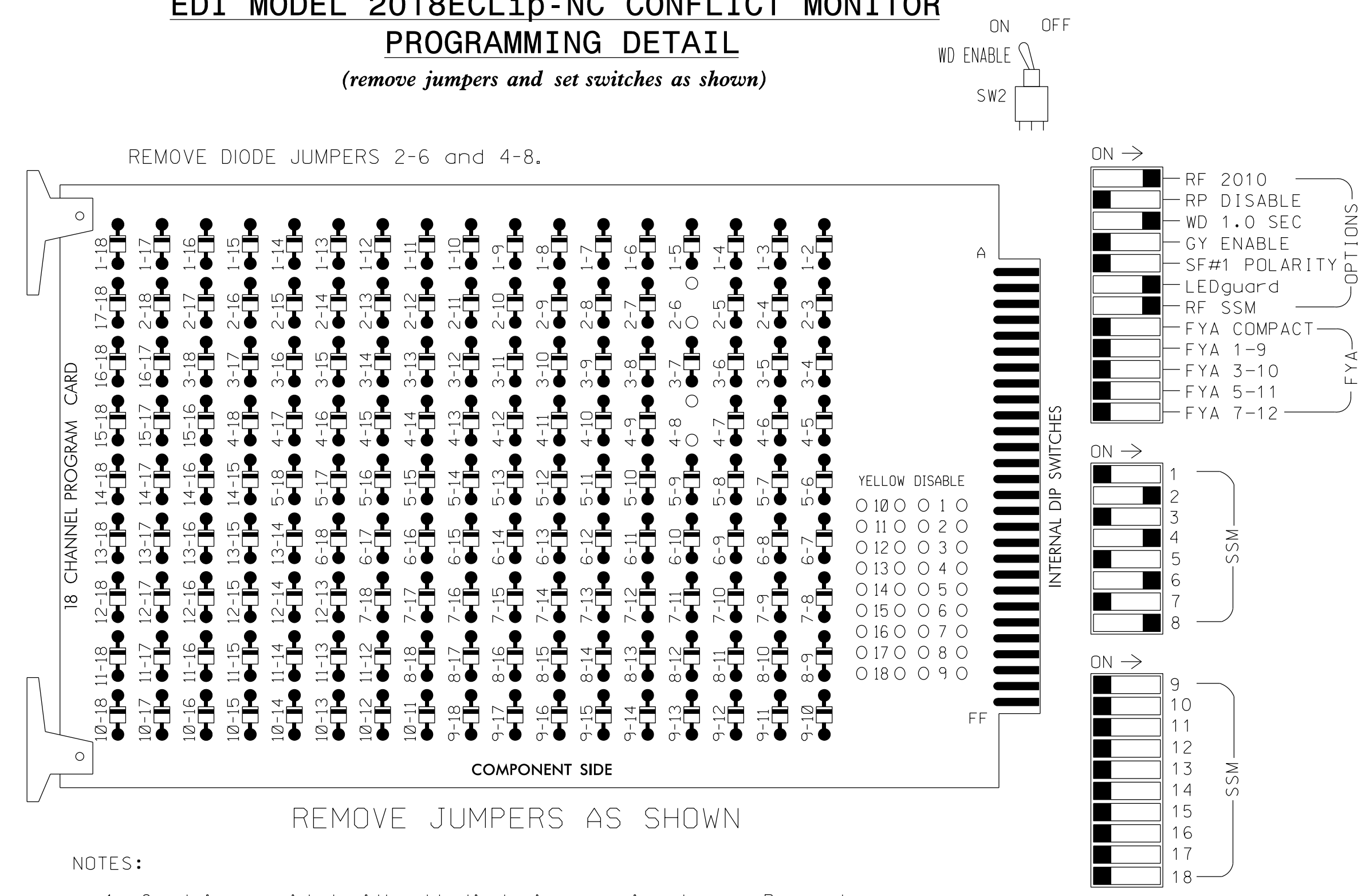

NOTES:

1. Card is provided with all diode jumpers in place. Removal of any jumper allows its channels to run concurrently.
2. Ensure jumpers SEL2-SEL5 and SEL9 are present on the monitor board.
3. Ensure that Red Enable is active at all times during normal operation.
4. Integrate monitor with Ethernet network in cabinet.

■ = DENOTES POSITION OF SWITCH

NOTES

1. To prevent "flash-conflict" problems, insert red flash program blocks for all unused vehicle load switches in the output file. The installer shall verify that signal heads flash in accordance with the Signal Plans.
2. Program controller to start up in phase 2 Green and 6 Green.
3. The cabinet and controller are part of the Burlington-Graham Signal System.

EQUIPMENT INFORMATION

CONTROLLER.....2070LX
 CABINET.....336
 SOFTWARE.....ECONDLITE ASC/3-2070
 CABINET MOUNT.....BASE
 OUTPUT FILE POSITIONS...12
 LOAD SWITCHES USED.....S2,S5,S8,S11
 PHASES USED.....2,4,6,8
 OVERLAPS.....NONE

SIGNAL HEAD HOOK-UP CHART

LOAD SWITCH NO.	S1	S2	S3	S4	S5	S6	S7	S8	S9	S10	S11	S12
CMU CHANNEL NO.	1	2	13	3	4	14	5	6	15	7	8	16
PHASE	1	2	2 PED	3	4	4 PED	5	6	6 PED	7	8	8 PED
SIGNAL HEAD NO.	NU	21,22	NU	NU	41,42	NU	NU	61,62	NU	NU	81,82	NU
RED		128			101			134			107	
YELLOW		129			102			135			108	
GREEN		130			103			136			109	
RED ARROW												
YELLOW ARROW												
GREEN ARROW												

NU = Not Used

INPUT FILE POSITION LAYOUT

(front view)

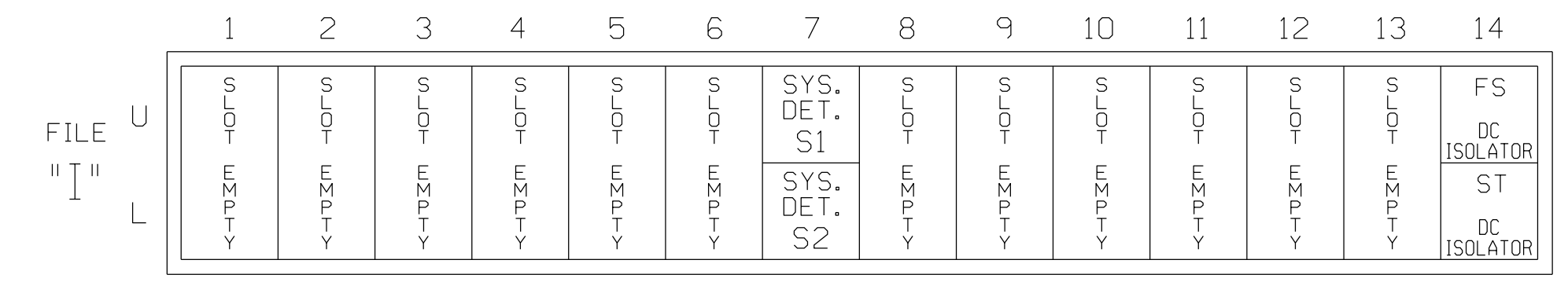

EX.: 1A, 2A, ETC. = LOOP NO.'S

FS = FLASH SENSE
 ST = STOP TIME

INPUT FILE CONNECTION & PROGRAMMING CHART

LOOP NO.	LOOP TERMINAL	INPUT FILE POS.	PIN NO.	DETECTOR NO.	NEMA PHASE	CALL	EXTEND TIME	DELAY TIME	ADDED INITIAL	DETECTOR TYPE
* S1	TB21-13,14	I7U	57	7	SYS	NO				N
* S2	TB23-13,14	I7L	50	28	SYS	NO				N

* System detector only. Remove any assigned vehicle phase.

INPUT FILE POSITION LEGEND: J2L

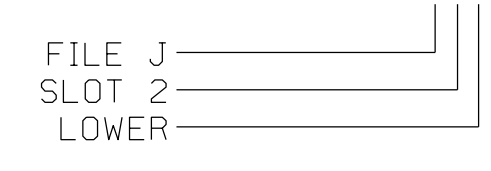

THIS ELECTRICAL DETAIL IS FOR
 THE SIGNAL DESIGN: B6229
 DESIGNED: NOVEMBER 2017
 SEALED: 06-14-2018
 REVISED: N/A

14-JUN-2018 11:42 R:\6605\work\edi\signal\design\wiring\B6229a.dgn dwhite AT CAR-DWHITE-LTW

Electrical Detail

DOCUMENT NOT CONSIDERED FINAL
 UNLESS ALL SIGNATURES COMPLETED

Plans Prepared By:

 DRMP, Inc.
 8000 Regency Parkway, Suite 175
 Cary, NC 27518
 NC License No. C-2213 (919) 650-1038

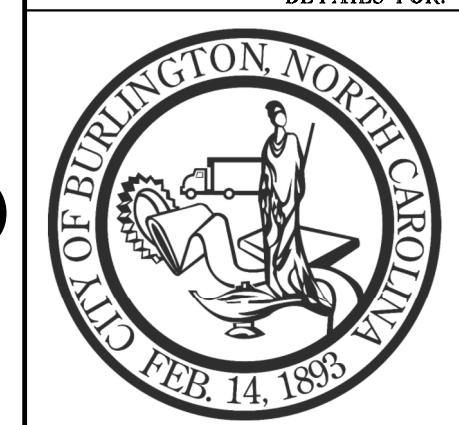

W. Davis Street
 at
 S. Worth Street

Division 7 Alamance County Burlington

PLAN DATE: November 2017 REVIEWED BY: AJ Davis

PREPARED BY: RD Lawton REVIEWED BY: LM Moon

REVISIONS	INIT.	DATE

SEAL

 Lisa M. Moon
 6/14/2018
 DATE
 SIG. INVENTORY NO. B6229

EDI MODEL 2018ECLip-NC CONFLICT MONITOR PROGRAMMING DETAIL

(remove jumpers and set switches as shown)

REMOVE DIODE JUMPERS 2-6, and 4-8.

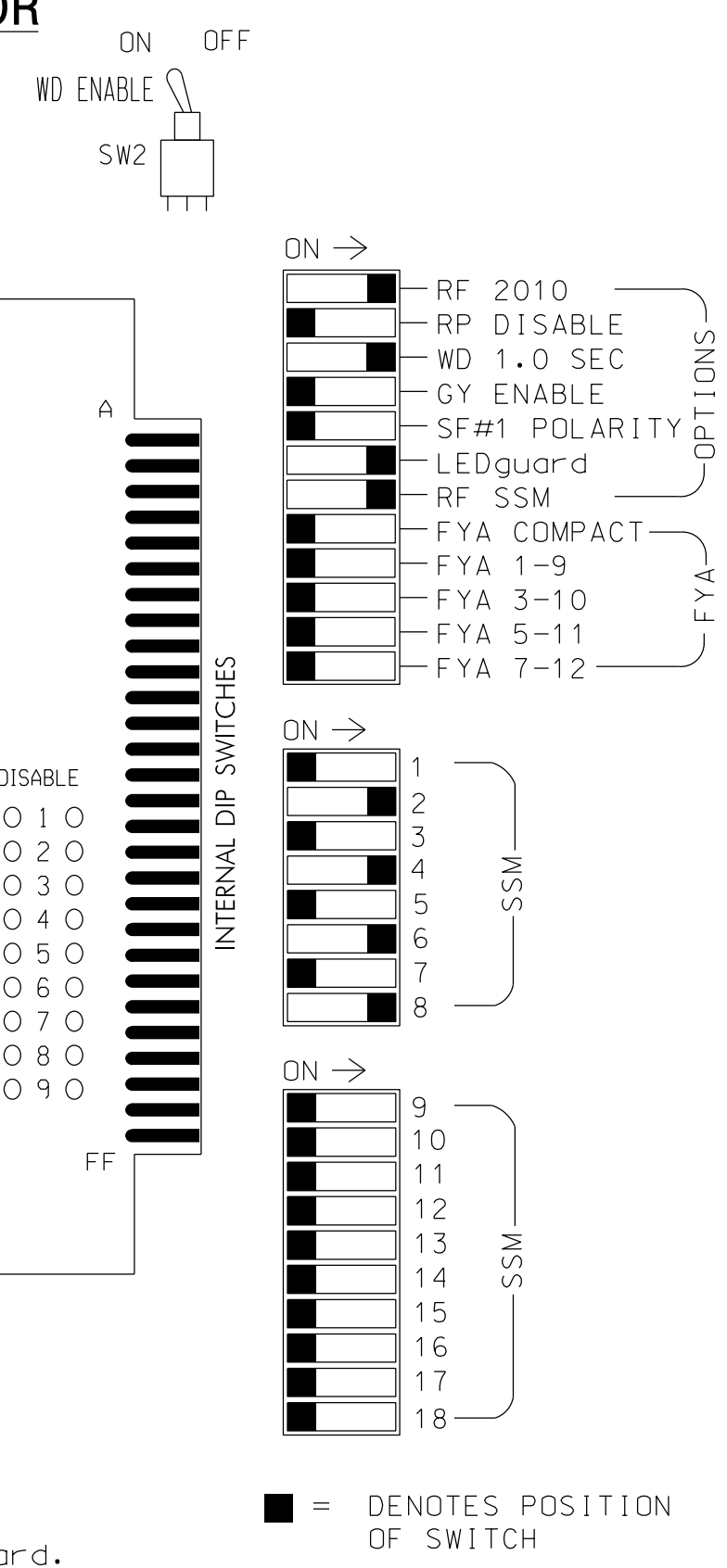
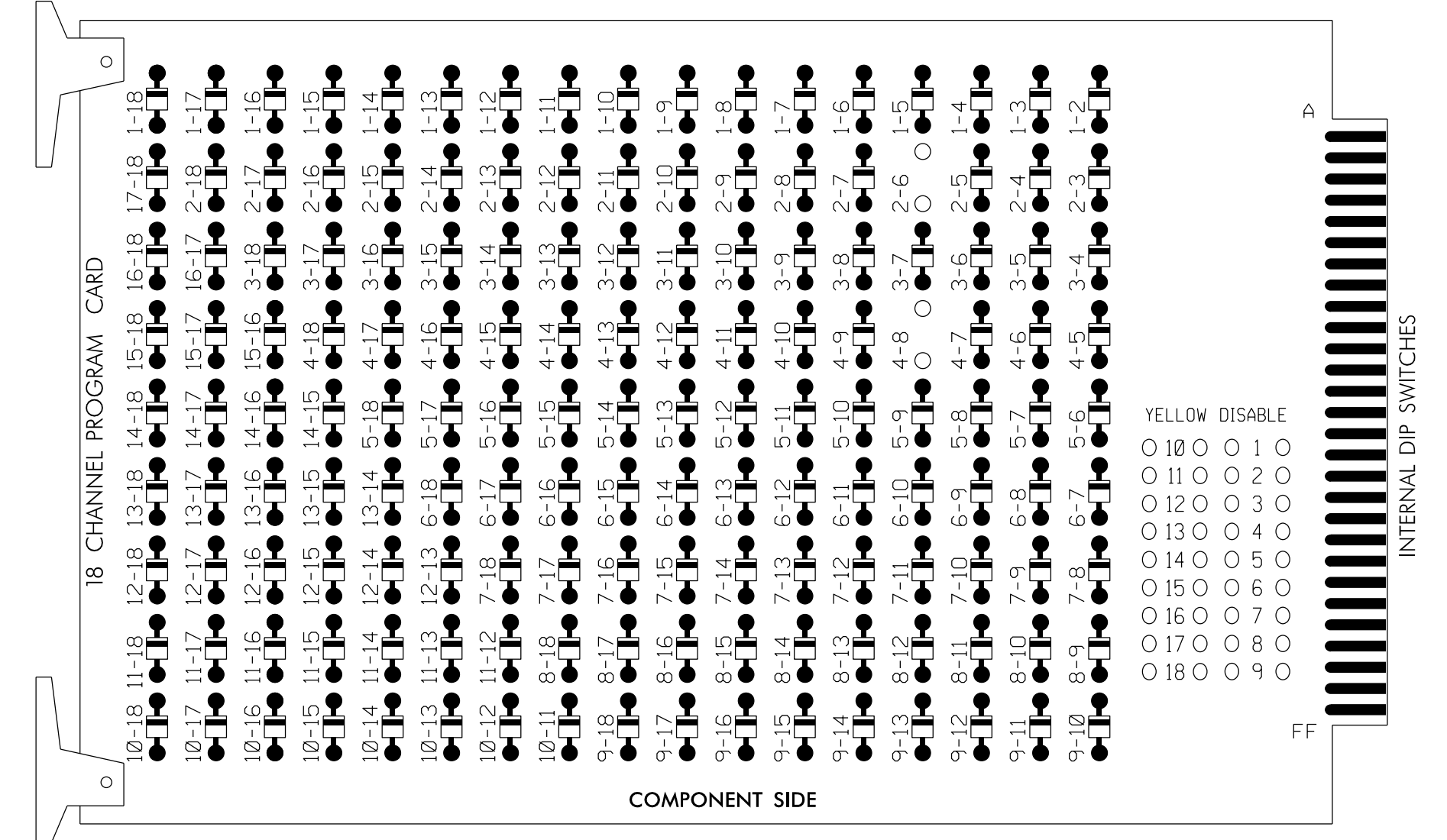

NOTES:

1. Card is provided with all diode jumpers in place. Removal of any jumper allows its channels to run concurrently.
2. Ensure jumpers SEL2-SEL5 and SEL9 are present on the monitor board.
3. Ensure that Red Enable is active at all times during normal operation.
4. Integrate monitor with Ethernet network in cabinet.

NOTES

1. To prevent "flash-conflict" problems, insert red flash program blocks for all unused vehicle load switches in the output file. The installer shall verify that signal heads flash in accordance with the Signal Plans.
2. Program controller to start up in phase 2 Green and 6 Green.
3. The cabinet and controller are part of the Burlington-Graham Signal System.

EQUIPMENT INFORMATION

CONTROLLER.....2070LX
 CABINET.....336
 SOFTWARE.....ECONDLITE ASC/3-2070
 CABINET MOUNT.....BASE
 OUTPUT FILE POSITIONS...12
 LOAD SWITCHES USED.....S2,S5,S8,S11
 PHASES USED.....2,4,6,8
 OVERLAPS.....NONE

SIGNAL HEAD HOOK-UP CHART

LOAD SWITCH NO.	S1	S2	S3	S4	S5	S6	S7	S8	S9	S10	S11	S12
CMU CHANNEL NO.	1	2	13	3	4	14	5	6	15	7	8	16
PHASE	1	2	2 PED	3	4	4 PED	5	6	6 PED	7	8	8 PED
SIGNAL HEAD NO.	NU	21,22	NU	NU	41,42	NU	NU	61,62	NU	NU	81,82	NU
RED		128			101			134			107	
YELLOW		129			102			135			108	
GREEN		130			103			136			109	
RED ARROW												
YELLOW ARROW												
GREEN ARROW												
Hand icon												
Person icon												

NU = Not Used

INPUT FILE POSITION LAYOUT

(front view)

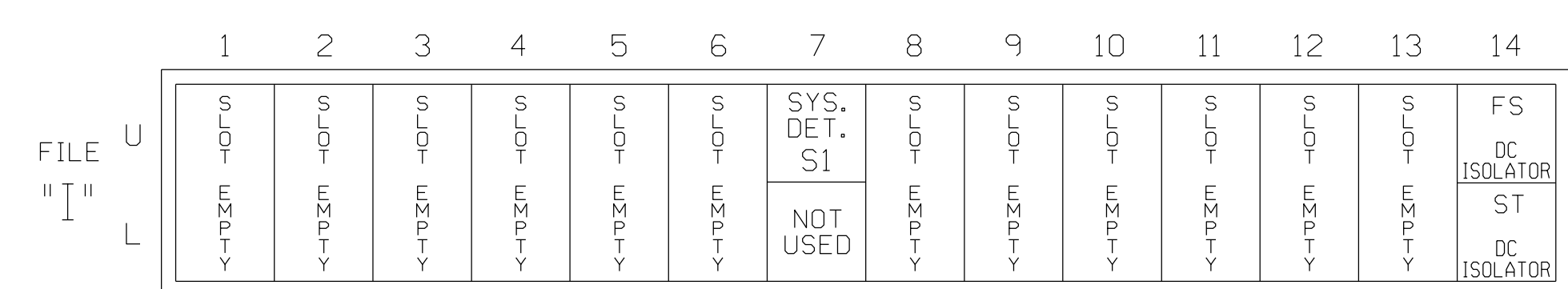

EX.: 1A, 2A, ETC. = LOOP NO.'S

FS = FLASH SENSE
 ST = STOP TIME

INPUT FILE CONNECTION & PROGRAMMING CHART

LOOP NO.	LOOP TERMINAL	INPUT FILE POS.	PIN NO.	DETECTOR NO.	NEMA PHASE	CALL	EXTEND TIME	DELAY TIME	ADDED INITIAL	DETECTOR TYPE
* S1	TB6-1,2	17U	65	34	SYS	NO				N

* System detector only. Remove any assigned vehicle phase.

INPUT FILE POSITION LEGEND: J2L

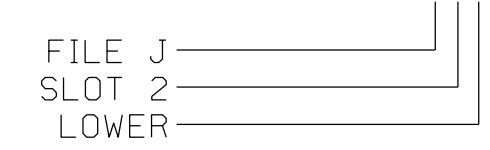

THIS ELECTRICAL DETAIL IS FOR
 THE SIGNAL DESIGN: B6468
 DESIGNED: JANUARY 2018
 SEALED: 06-14-2018
 REVISED: N/A

14-JUN-2018 11:38 R:\6015\17\offices\gnols\design\wiring\B6468a.dgn dwhite AT CAR-DWHITE-LTW

Electrical Detail

DOCUMENT NOT CONSIDERED FINAL
 UNLESS ALL SIGNATURES COMPLETED



S. Worth Street at Maple Avenue	
Division 7	Alamance County
PLAN DATE: January 2018	REVIEWED BY: AJ Davis
PREPARED BY: DJ White	REVIEWED BY: LM Moon
REVISIONS	INIT. DATE

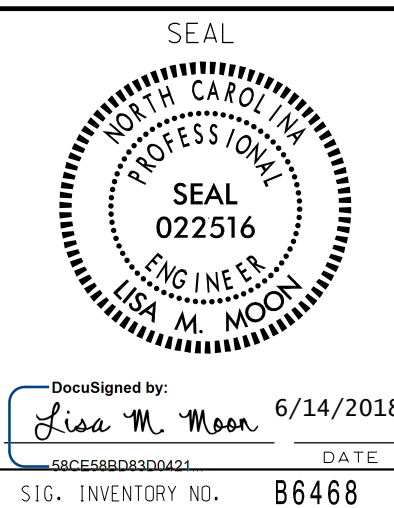

DocuSigned by:
 Lisa M. Moon
 6/14/2018
 DATE
 SIG. INVENTORY NO. B6468

EDI MODEL 2018ECLip-NC CONFLICT MONITOR PROGRAMMING DETAIL

(remove jumpers and set switches as shown)

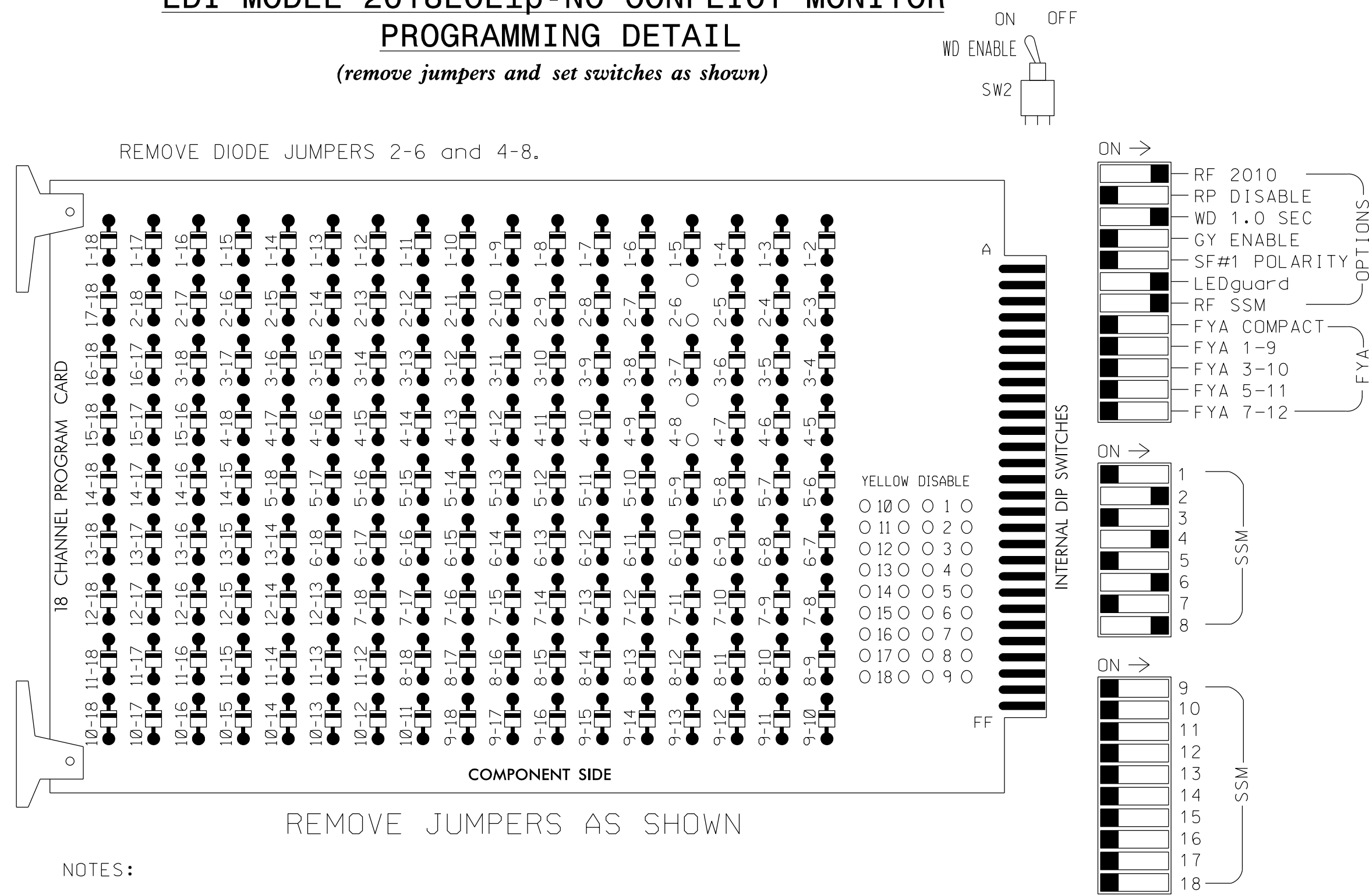

NOTES:

1. Card is provided with all diode jumpers in place. Removal of any jumper allows its channels to run concurrently.
2. Ensure jumpers SEL2-SEL5 and SEL9 are present on the monitor board.
3. Ensure that Red Enable is active at all times during normal operation.
4. Integrate monitor with Ethernet network in cabinet.

NOTES

1. To prevent "flash-conflict" problems, insert red flash program blocks for all unused vehicle load switches in the output file. The installer shall verify that signal heads flash in accordance with the Signal Plans.
2. Program controller to start up in phase 2 Green and 6 Green.
3. The cabinet and controller are part of the Burlington-Graham Signal System.

EQUIPMENT INFORMATION

CONTROLLER.....2070LX
 CABINET.....336
 SOFTWARE.....ECONDLITE ASC/3-2070
 CABINET MOUNT.....BASE
 OUTPUT FILE POSITIONS...12
 LOAD SWITCHES USED.....S2,S5,S8,S11
 PHASES USED.....2,4,6,8
 OVERLAPS.....NONE

SIGNAL HEAD HOOK-UP CHART

LOAD SWITCH NO.	S1	S2	S3	S4	S5	S6	S7	S8	S9	S10	S11	S12
CMU CHANNEL NO.	1	2	13	3	4	14	5	6	15	7	8	16
PHASE	1	2	2 PED	3	4	4 PED	5	6	6 PED	7	8	8 PED
SIGNAL HEAD NO.	NU	21,22	NU	NU	41,42	NU	NU	61,62	NU	NU	81,82	NU
RED		128			101			134			107	
YELLOW		129			102			135			108	
GREEN		130			103			136			109	
RED ARROW												
YELLOW ARROW												
GREEN ARROW												

NU = Not Used

INPUT FILE POSITION LAYOUT

(front view)

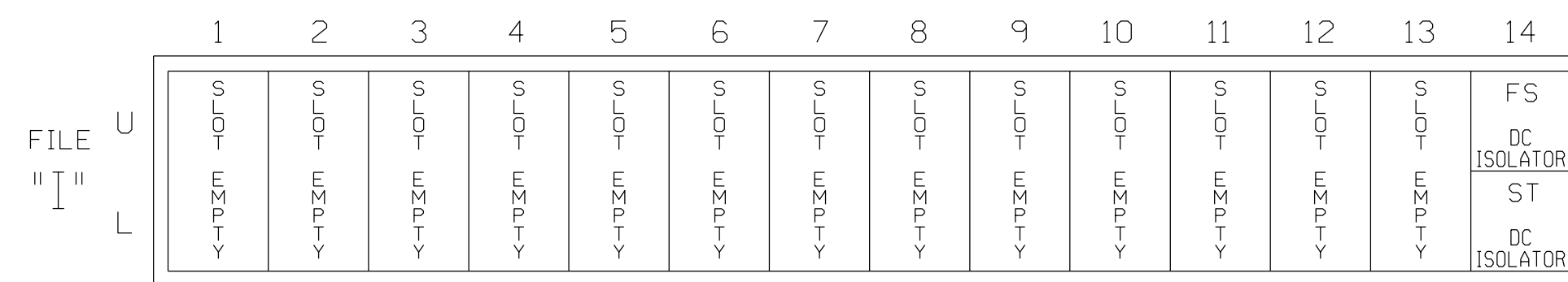

THIS ELECTRICAL DETAIL IS FOR
 THE SIGNAL DESIGN: B6469
 DESIGNED: NOVEMBER 2017
 SEALED: 06-13-2018
 REVISED: N/A

Electrical Detail

DOCUMENT NOT CONSIDERED FINAL
 UNLESS ALL SIGNATURES COMPLETED

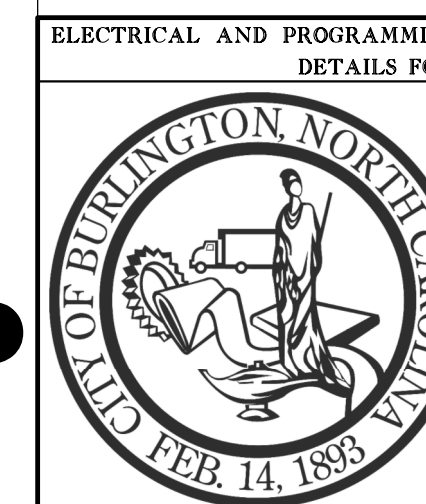

Maple Avenue at S. Spring Street	
Division 7	Alamance County Burlington
PLAN DATE: November 2017	REVIEWED BY: AJ Davis
PREPARED BY: RD Lawton	REVIEWED BY: LM Moon
REVISIONS	INIT. DATE

DocuSigned by:
Lisa M. Moon
 6/13/2018
 DATE
 SIG. INVENTORY NO. B6469



EDI MODEL 2018ECLip-NC CONFLICT MONITOR PROGRAMMING DETAIL

(remove jumpers and set switches as shown)

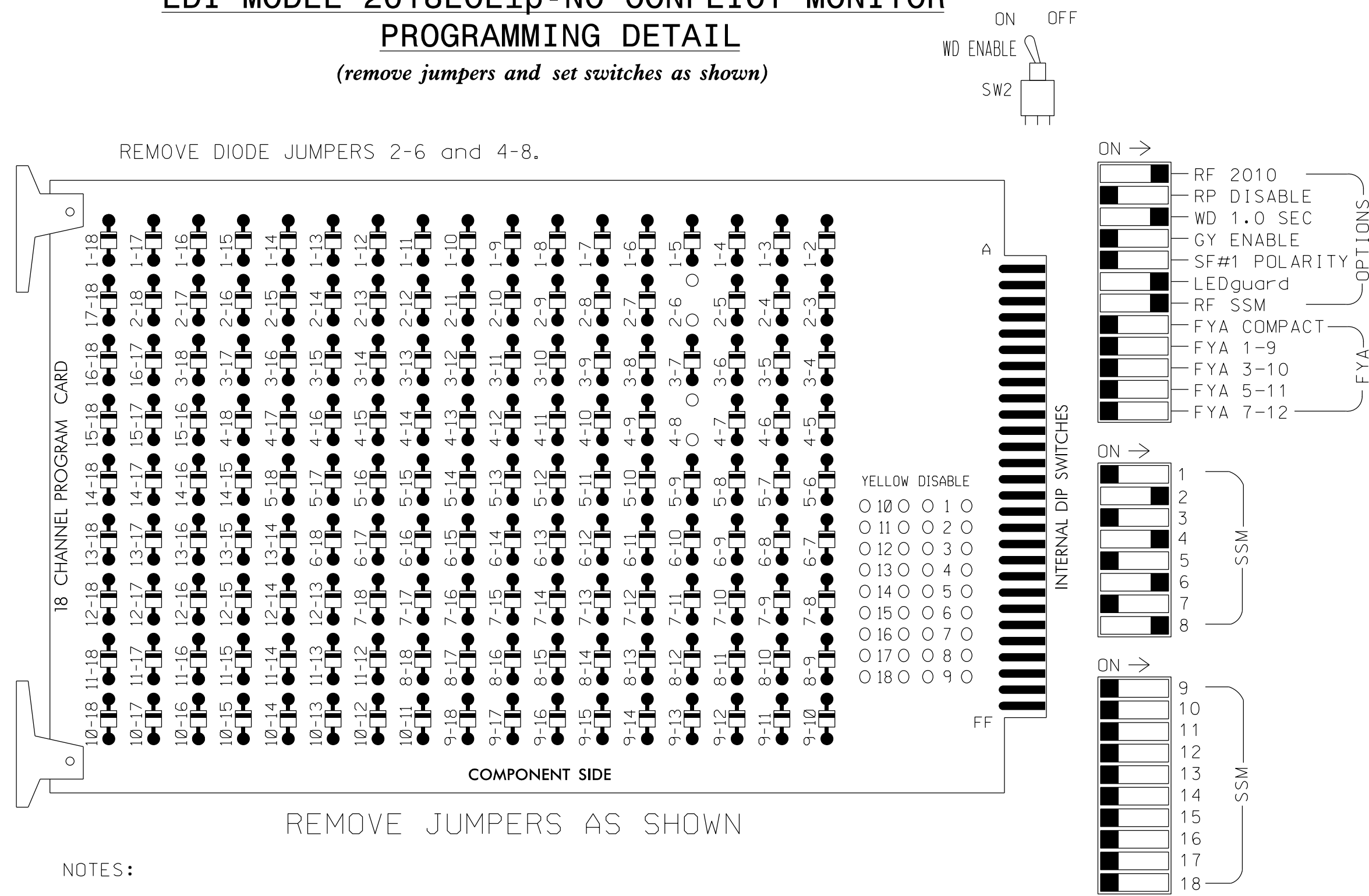

NOTES:

- Card is provided with all diode jumpers in place. Removal of any jumper allows its channels to run concurrently.
- Ensure jumpers SEL2-SEL5 and SEL9 are present on the monitor board.
- Ensure that Red Enable is active at all times during normal operation.
- Integrate monitor with Ethernet network in cabinet.

NOTES

- To prevent "flash-conflict" problems, insert red flash program blocks for all unused vehicle load switches in the output file. The installer shall verify that signal heads flash in accordance with the Signal Plans.
- Program controller to start up in phase 2 Green and 6 Green.
- The cabinet and controller are part of the Burlington-Graham Signal System.

EQUIPMENT INFORMATION

CONTROLLER.....2070LX
 CABINET.....336
 SOFTWARE.....ECONDLITE ASC/3-2070
 CABINET MOUNT.....BASE
 OUTPUT FILE POSITIONS...12
 LOAD SWITCHES USED.....S2,S5,S8,S11
 PHASES USED.....2,4,6,8
 OVERLAPS.....NONE

SIGNAL HEAD HOOK-UP CHART

LOAD SWITCH NO.	S1	S2	S3	S4	S5	S6	S7	S8	S9	S10	S11	S12
CMU CHANNEL NO.	1	2	13	3	4	14	5	6	15	7	8	16
PHASE	1	2	2 PED	3	4	4 PED	5	6	6 PED	7	8	8 PED
SIGNAL HEAD NO.	NU	21,22	NU	NU	41,42	NU	NU	61,62	NU	NU	81,82	NU
RED		128			101			134			107	
YELLOW		129			102			135			108	
GREEN		130			103			136			109	
RED ARROW												
YELLOW ARROW												
GREEN ARROW												

NU = Not Used

INPUT FILE POSITION LAYOUT

(front view)

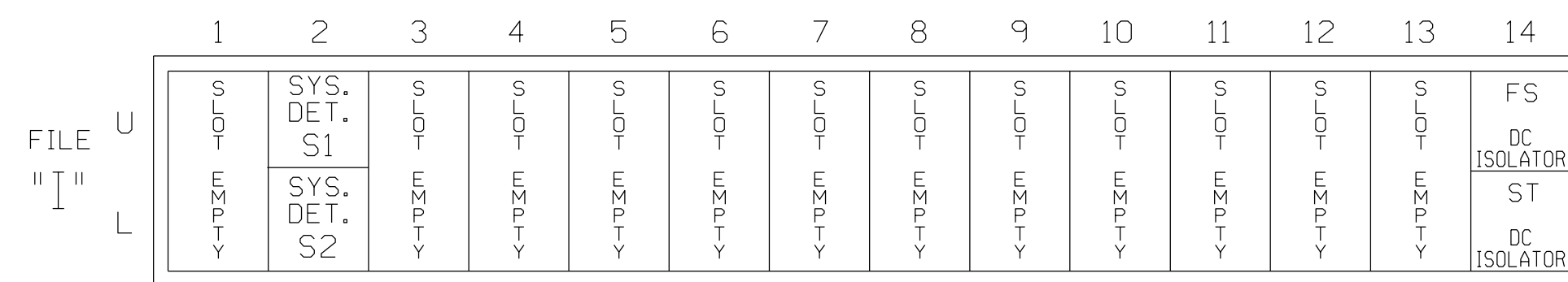

EX. : 1A, 2A, ETC. = LOOP NO.'S

FS = FLASH SENSE
ST = STOP TIME

INPUT FILE CONNECTION & PROGRAMMING CHART

LOOP NO.	LOOP TERMINAL	INPUT FILE POS.	PIN NO.	DETECTOR NO.	NEMA PHASE	CALL	EXTEND TIME	DELAY TIME	ADDED INITIAL	DETECTOR TYPE
* S1	TB21-3,4	12U	39	2	SYS	NO				N

* System detector only. Remove any assigned vehicle phase.

INPUT FILE POSITION LEGEND: J2L

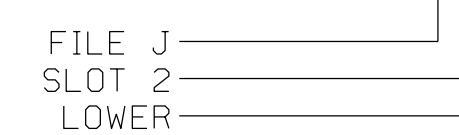

THIS ELECTRICAL DETAIL IS FOR
 THE SIGNAL DESIGN: B6765
 DESIGNED: NOVEMBER 2017
 SEALED: 06-14-2018
 REVISED: N/A

Electrical Detail

DOCUMENT NOT CONSIDERED FINAL
UNLESS ALL SIGNATURES COMPLETED

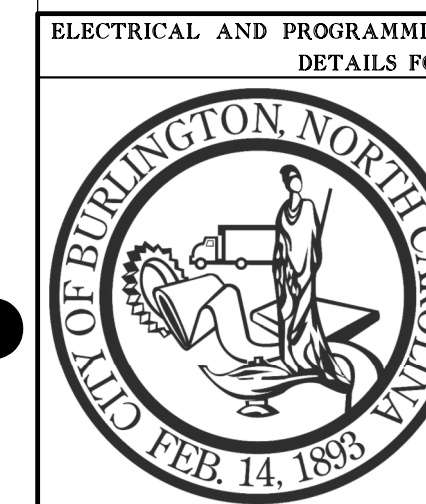

Plans Prepared By:
DRMP
 DRMP, Inc.
 8000 Regency Parkway, Suite 175
 Cary, NC 27519
 NC License No. C-2213 (919) 650-1038

S. Worth Street at W. Morehead Street	
Division 7	Alamance County Burlington
PLAN DATE: November 2017	REVIEWED BY: AJ Davis
PREPARED BY: RD Lawton	REVIEWED BY: LM Moon
REVISIONS	INIT. DATE

SEAL
 NORTH CAROLINA
 PROFESSIONAL
 SEAL
 022516
 ENGINEER
 LISA M. MOON

DocuSigned by:
 Lisa M. Moon
 6/14/2018
 DATE
 SIG. INVENTORY NO. B6765

PHASING DIAGRAM

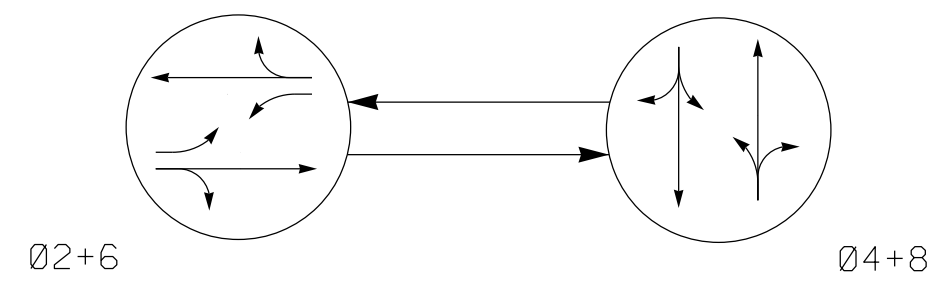

PHASING DIAGRAM DETECTION LEGEND

- ◄●► DETECTED MOVEMENT
- ◄◄◄ UNDETECTED MOVEMENT (OVERLAP)
- ◄- - - UNSIGNALIZED MOVEMENT
- ◄- - - PEDESTRIAN MOVEMENT

TABLE OF OPERATION

SIGNAL FACE	PHASE		
	02+6	04+8	FLASH
21, 22	G	R	Y
41, 42	R	G	R
61, 62	G	R	Y
81, 82	R	G	R

SIGNAL FACE I.D.

All Heads L.E.D.

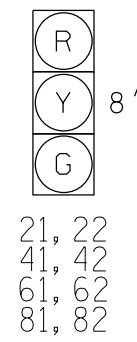

2 Phase Pretimed (Burlington-Graham Signal System)

NOTES

- Refer to "Roadway Standard Drawings NCDOT" dated January 2018 and "Standard Specifications for Roads and Structures" dated January 2018.
- Do not program signal for late night flashing operation unless otherwise directed by the Engineer.
- Locate new cabinet so as not to obstruct sight distance of vehicles turning right on red.
- Lane control signs may be removed at the discretion of the City Traffic Engineer.
- Pavement markings are existing.
- Maximum times shown in timing chart are for free-run operation only. Coordinated signal system timing values supersede these values.

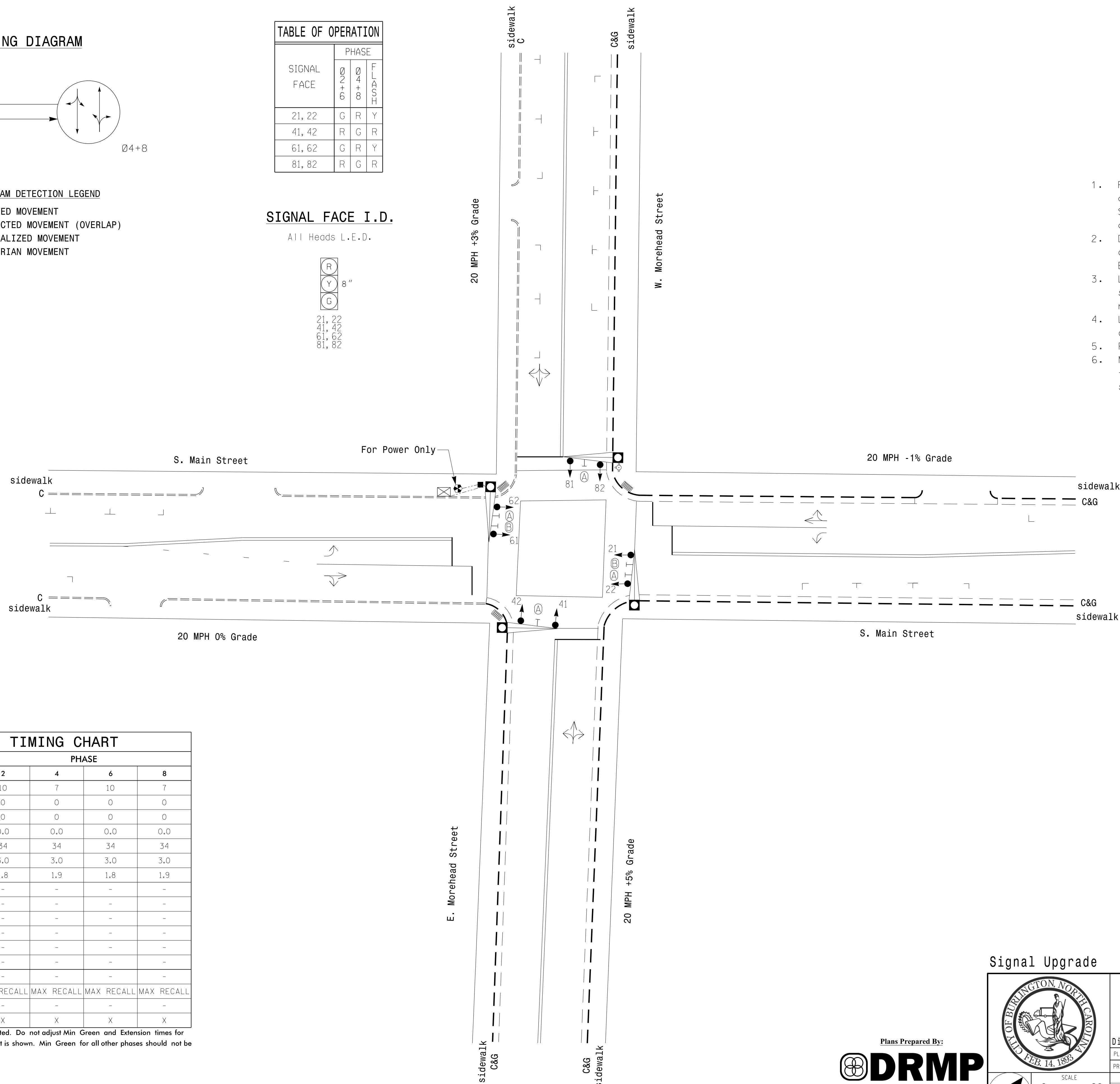

ASC/3 TIMING CHART

FEATURE	PHASE			
	2	4	6	8
Min Green *	10	7	10	7
Walk *	0	0	0	0
Ped Clear	0	0	0	0
Veh. Extension *	0.0	0.0	0.0	0.0
Max 1 *	34	34	34	34
Yellow	3.0	3.0	3.0	3.0
Red Clear	1.8	1.9	1.8	1.9
Actuations B4 Add *	-	-	-	-
Seconds /Actuation *	-	-	-	-
Max Initial *	-	-	-	-
Time Before Reduction *	-	-	-	-
Time To Reduce *	-	-	-	-
Minimum Gap	-	-	-	-
Locking Detector	-	-	-	-
Recall Position	MAX	RECALL	MAX	RECALL
Dual Entry	-	-	-	-
Simultaneous Gap	X	X	X	X

* These values may be field adjusted. Do not adjust Min Green and Extension times for phases 2 and 6 lower than what is shown. Min Green for all other phases should not be lower than 4 seconds.

LEGEND

PROPOSED	EXISTING
○	●
◐	◑
◒	◓
◔	◕
◖	◗
◘	◙
◚	◛
◜	◝
◞	◟
◠	◡
◢	◣
◤	◥
◦	◧
◨	◩
◪	◫
◬	◭
◮	◯
◰	◱
◲	◳
◴	◵
◷	◸
◹	◺
◻	◼
◽	◾
◿	◿

Signal Upgrade

DOCUMENT NOT CONSIDERED FINAL UNLESS ALL SIGNATURES COMPLETED

Plans Prepared By:
DRMP
DRMP, Inc.
8000 Regency Parkway, Suite 175
Cary, NC 27519
NC License No. C-2213 (919) 650-1038

S. Main Street at Morehead Street

Division 7 Alamance County Burlington

PLAN DATE: November 2017 REVIEWED BY: AJ Davis

PREPARED BY: RD Lawton REVIEWED BY: LM Moon

REVISIONS: _____ INIT. DATE

SEAL

DocuSigned by:
Lisa M. Moon, 6/13/2018
SIC65880300421
DATE: _____
SIG. INVENTORY NO. B6766

13-JUN-2018 10:01 R:\66015\Traffic\Signal\Burlington\Signal\B6766.dgn KANDERSON AT CHA-Y.ANDERSON

EDI MODEL 2018ECLip-NC CONFLICT MONITOR PROGRAMMING DETAIL

(remove jumpers and set switches as shown)

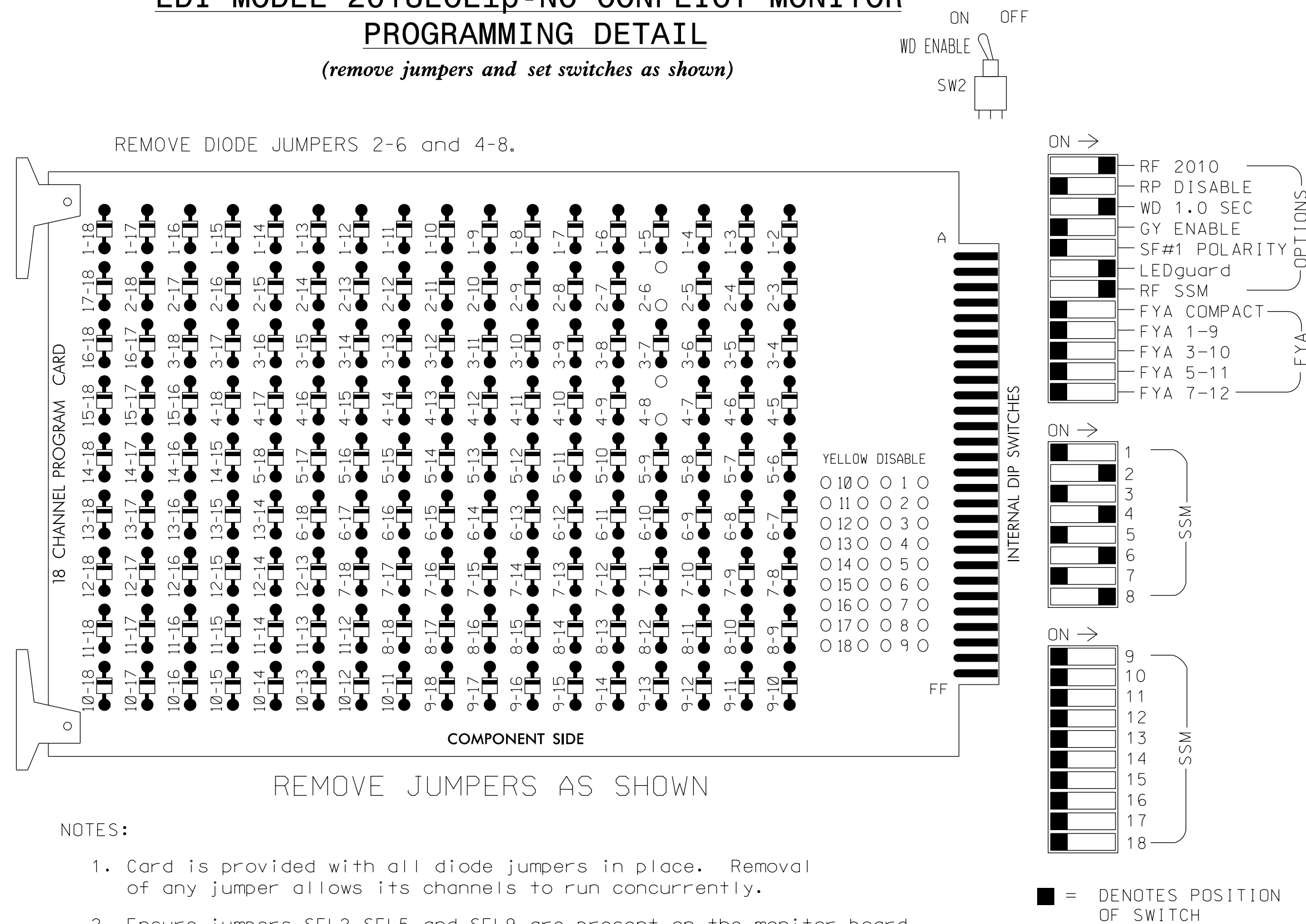

NOTES

- To prevent "flash-conflict" problems, insert red flash program blocks for all unused vehicle load switches in the output file. The installer shall verify that signal heads flash in accordance with the Signal Plans.
- Program controller to start up in phase 2 Green and 6 Green.
- The cabinet and controller are part of the Burlington-Graham System.

SIGNAL HEAD HOOK-UP CHART

LOAD SWITCH NO.	S1	S2	S3	S4	S5	S6	S7	S8	S9	S10	S11	S12
CMU CHANNEL NO.	1	2	13	3	4	14	5	6	15	7	8	16
PHASE	1	2	2 PED	3	4	4 PED	5	6	6 PED	7	8	8 PED
SIGNAL HEAD NO.	NU	21,22	NU	NU	41,42	NU	NU	61,62	NU	NU	81,82	NU
RED		128			101			134			107	
YELLOW		129			102			135			108	
GREEN		130			103			136			109	
RED ARROW												
YELLOW ARROW												
GREEN ARROW												

NU = Not Used

EQUIPMENT INFORMATION

CONTROLLER.....2070LX
 CABINET.....336
 SOFTWARE.....ECONDLITE ASC/3-2070
 CABINET MOUNT.....BASE
 OUTPUT FILE POSITIONS...12
 LOAD SWITCHES USED.....S2,S5,S8,S11
 PHASES USED.....2,4,6,8
 OVERLAPS.....NONE

INPUT FILE POSITION LAYOUT

(front view)

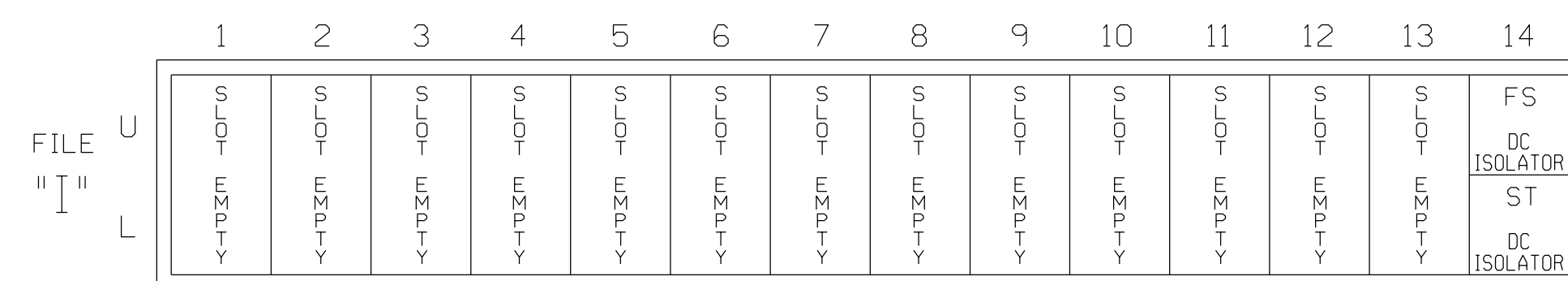

EX.: 1A, 2A, ETC. = LOOP NO.'S

FS = FLASH SENSE
 ST = STOP TIME

THIS ELECTRICAL DETAIL IS FOR THE SIGNAL DESIGN: B6766
 DESIGNED: NOVEMBER 2017
 SEALED: 06-13-2018
 REVISED: N/A

Electrical Detail

ELECTRICAL AND PROGRAMMING DETAILS FOR:



Plans Prepared By:
DRMP
 DRMP, Inc.
 8000 Regency Parkway, Suite 175
 Cary, NC 27519
 NC License No. C-2213 (919) 650-1038

S. Main Street at Morehead Street	
Division 7	Alamance County
Alamance County	Burlington
PLAN DATE: November 2017	REVIEWED BY: AJ Davis
PREPARED BY: DJ White	REVIEWED BY: LM Moon
REVISIONS	INIT. DATE

DOCUMENT NOT CONSIDERED FINAL UNLESS ALL SIGNATURES COMPLETED



DocuSigned by:
 Lisa M. Moon
 6/13/2018
 DATE
 SIG. INVENTORY NO. B6766

EDI MODEL 2018ECLip-NC CONFLICT MONITOR PROGRAMMING DETAIL

(remove jumpers and set switches as shown)

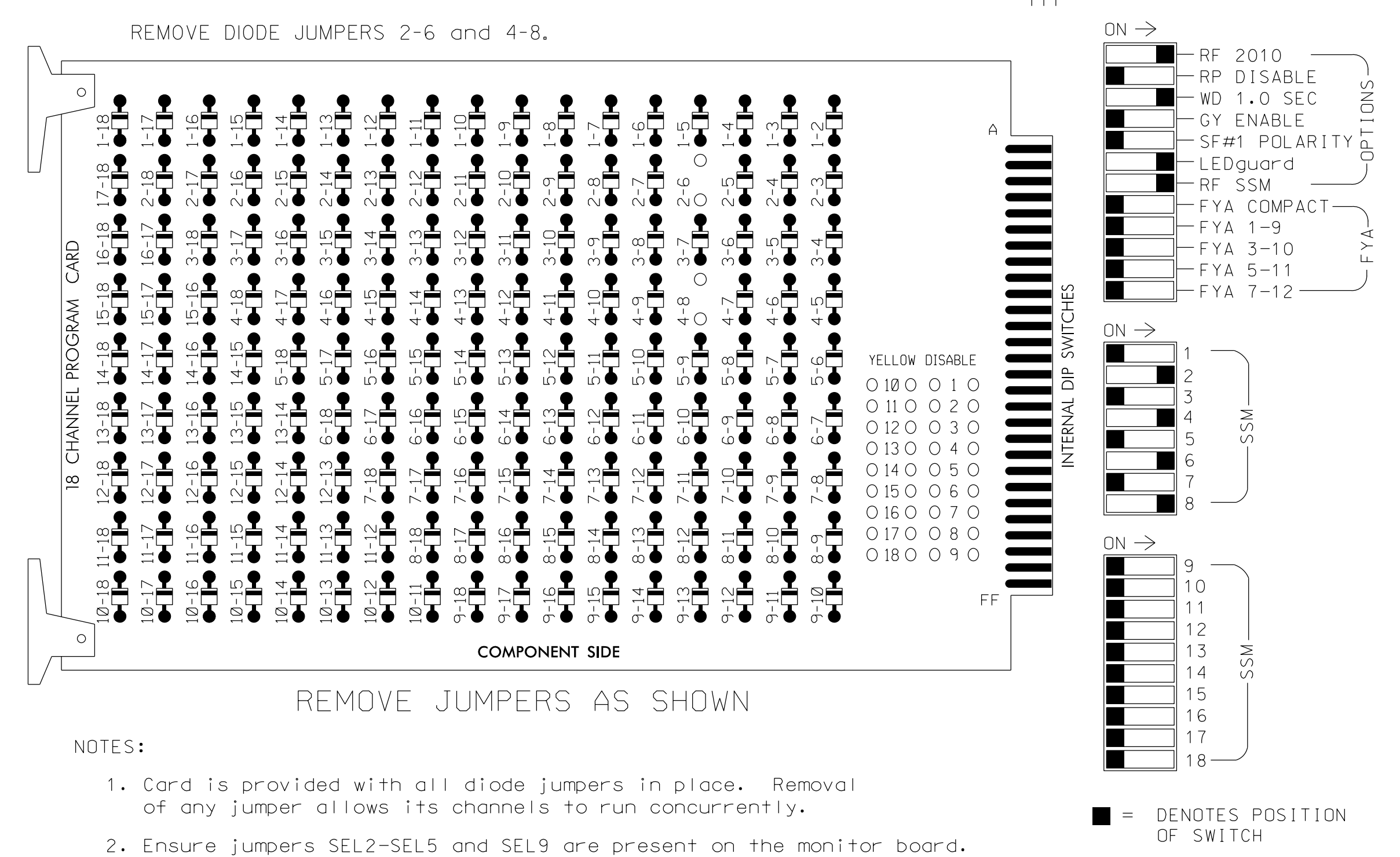

NOTES

- To prevent "flash-conflict" problems, insert red flash program blocks for all unused vehicle load switches in the output file. The installer shall verify that signal heads flash in accordance with the Signal Plans.
- Program controller to start up in phase 2 Green and 6 Green.
- The cabinet and controller are part of the Burlington-Graham Signal System.

SIGNAL HEAD HOOK-UP CHART

LOAD SWITCH NO.	S1	S2	S3	S4	S5	S6	S7	S8	S9	S10	S11	S12
CMU CHANNEL NO.	1	2	13	3	4	14	5	6	15	7	8	16
PHASE	1	2	2 PED	3	4	4 PED	5	6	6 PED	7	8	8 PED
SIGNAL HEAD NO.	NU	21,22	NU	NU	41,42	NU	NU	61,62	NU	NU	81,82	NU
RED		128			101			134			107	
YELLOW		129			102			135			108	
GREEN		130			103			136			109	
RED ARROW												
YELLOW ARROW												
GREEN ARROW												

NU = Not Used

EQUIPMENT INFORMATION

CONTROLLER.....2070LX
 CABINET.....336
 SOFTWARE.....ECONDLITE ASC/3-2070
 CABINET MOUNT.....BASE
 OUTPUT FILE POSITIONS...12
 LOAD SWITCHES USED.....S2,S5,S8,S11
 PHASES USED.....2,4,6,8
 OVERLAPS.....NONE

INPUT FILE POSITION LAYOUT

(front view)

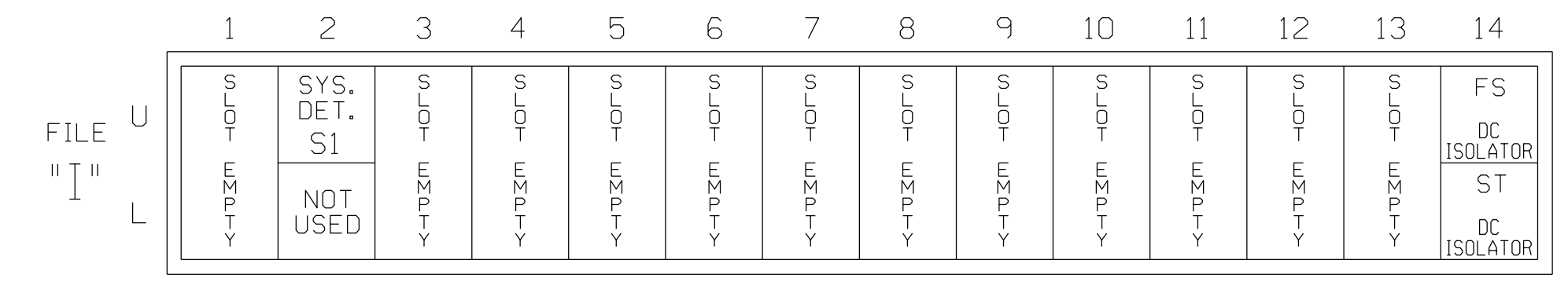

INPUT FILE CONNECTION & PROGRAMMING CHART

LOOP NO.	LOOP TERMINAL	INPUT FILE POS.	PIN NO.	DETECTOR NO.	NEMA PHASE	CALL	EXTEND TIME	DELAY TIME	ADDED INITIAL	DETECTOR TYPE
* S1	TB21-3,4	I2U	39	2	SYS					N

* System detector only. Remove any assigned vehicle phase.

INPUT FILE POSITION LEGEND: J2L

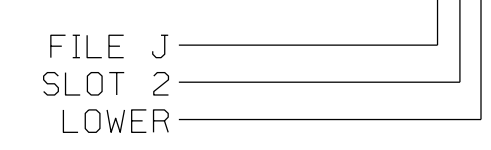

THIS ELECTRICAL DETAIL IS FOR THE SIGNAL DESIGN: B6767
 DESIGNED: NOVEMBER 2017
 SEALED: 06-13-2018
 REVISED: N/A

13-UNA-2018-18-01
R:\66015\Traf\ek\signals\des\gm\wlr\ing\B6767e.dgn
KANDERSON AT CHA-KANDERSON

Electrical Detail

ELECTRICAL AND PROGRAMMING DETAILS FOR:



Plans Prepared By:
DRMP
 DRMP, Inc.
 8000 Regency Parkway, Suite 175
 Cary, NC 27519
 NC License No. C-2213 (919) 650-1038

**S. Main Street
at
Fifth Street**

Division 7 Alamance County Burlington

PLAN DATE: November 2017 REVIEWED BY: AJ Davis
 PREPARED BY: DJ White REVIEWED BY: LM Moon

REVISIONS	INIT.	DATE

DOCUMENT NOT CONSIDERED FINAL UNLESS ALL SIGNATURES COMPLETED



DocuSigned by:
 Lisa M. Moon
 6/13/2018
 DATE
 SIG. INVENTORY NO. B6767

PHASING DIAGRAM

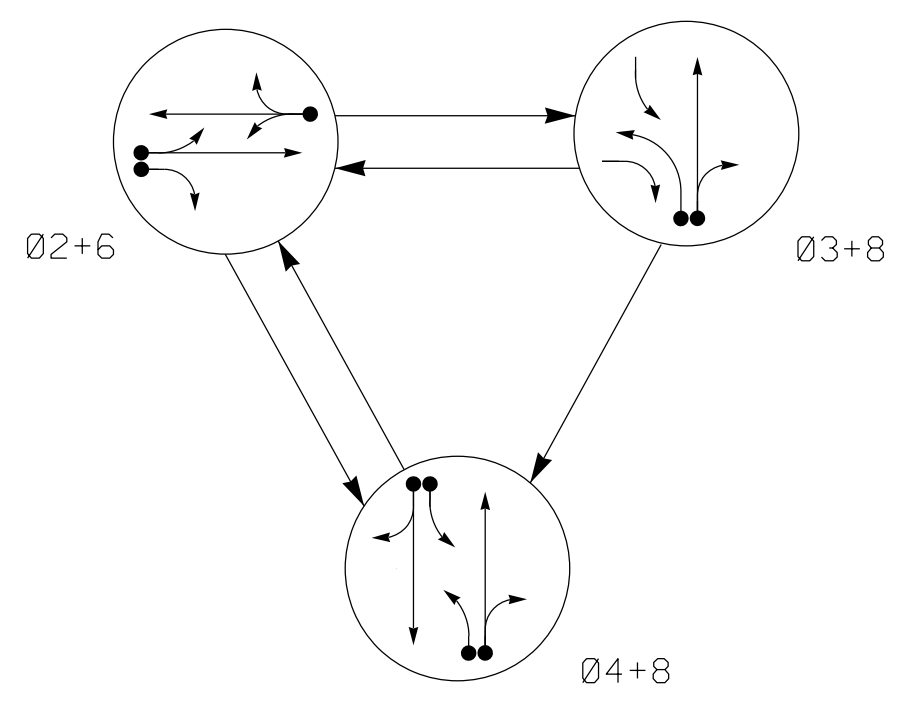
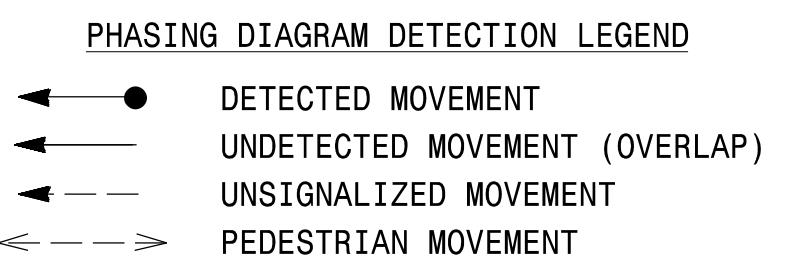

TABLE OF OPERATION

SIGNAL FACE	PHASE				
	02+6	03+8	04+8	F	F
21,23	G	R	R	Y	
22	G	R	R	Y	
31	R	R	R	Y	
41	R	R	R	Y	
42,43,44	R	R	R	Y	
61,62	G	R	R	Y	
81,82	R	G	G	R	



SIGNAL FACE I.D.

All Heads L.E.D.

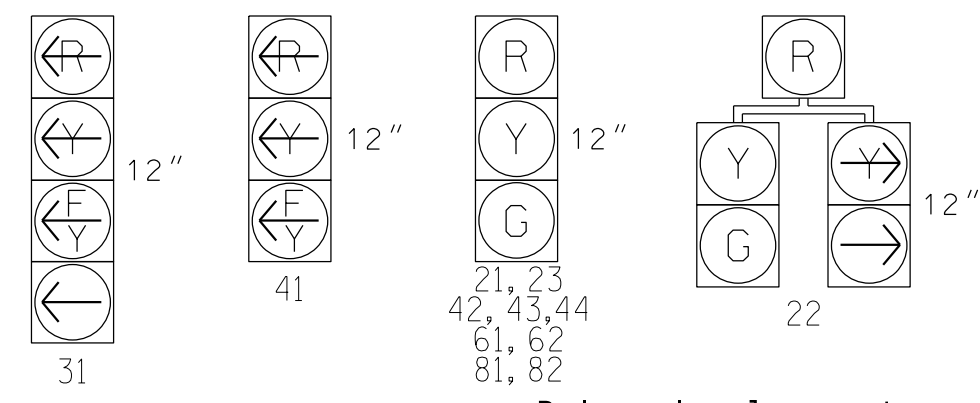

ASC/3 DETECTOR INSTALLATION CHART

LOOP	SIZE (FT)	DISTANCE FROM STOPBAR (FT)	TURNS	NEW LOOP	PROGRAMMING							
					PHASE	CALLING	EXTEND TIME	DELAY TIME	USE ADDED INITIAL	TYPE	SYSTEM LOOP	NEW CARD
2A	6x6	70	Exist	-	2	Yes	-	-	-	S	-	X
2B	6x40	0	2-4-2	-	2	Yes	-	-	-	S	-	X
3A	6x60	+10	Exist	-	3	Yes	-	15	-	S	-	X
4A	6x40	0	Exist	-	4	Yes	-	3	-	S	-	X
4B	6x60	0	Exist	-	4	Yes	-	10	-	S	-	X
6A	6x6	70	Exist	-	6	Yes	-	-	-	S	-	X
8A	6x40	+10	Exist	-	8	Yes	-	10	-	S	-	X
S1	6x6	+147	3	X	-	No	-	-	-	N	X	X
S2	6x6	+147	3	X	-	No	-	-	-	N	X	X

3 Phase Fully Actuated (Burlington-Graham Signal System)

NOTES

- Refer to "Roadway Standard Drawings NCDOT" dated January 2018 and "Standard Specifications for Roads and Structures" dated January 2018.
- Do not program signal for late night flashing operation unless otherwise directed by the Engineer.
- Loop data based on previous plan and field observations.
- Phase 3 may be lagged
- Set all detector units to presence mode.
- In the event of loop replacement, refer to the current ITS and Signals Design Manual and submit a Plan of Record to the Signal Design Section.
- Locate new cabinet so as not to obstruct sight distance of vehicles turning right on red.
- Remove existing "Left Turn Yield on Green" ball sign(s)-(R10-12) from Northbound Tarleton Avenue.
- Install new signal head 41, center it on left lane and reposition signal heads 42 and 43 to maintain 8' min. separation between phase 4 signal heads.
- Raise existing messenger to achieve a minimum clearance for the new signal heads. Suggested adjustments are shown on plan but it is contractors responsibility to meet minimum clearance.
- Reposition signal head 82 as shown.
- Pavement markings are existing.
- Maximum times shown in timing chart are for free-run operation only. Coordinated signal system timing values supersede these values.

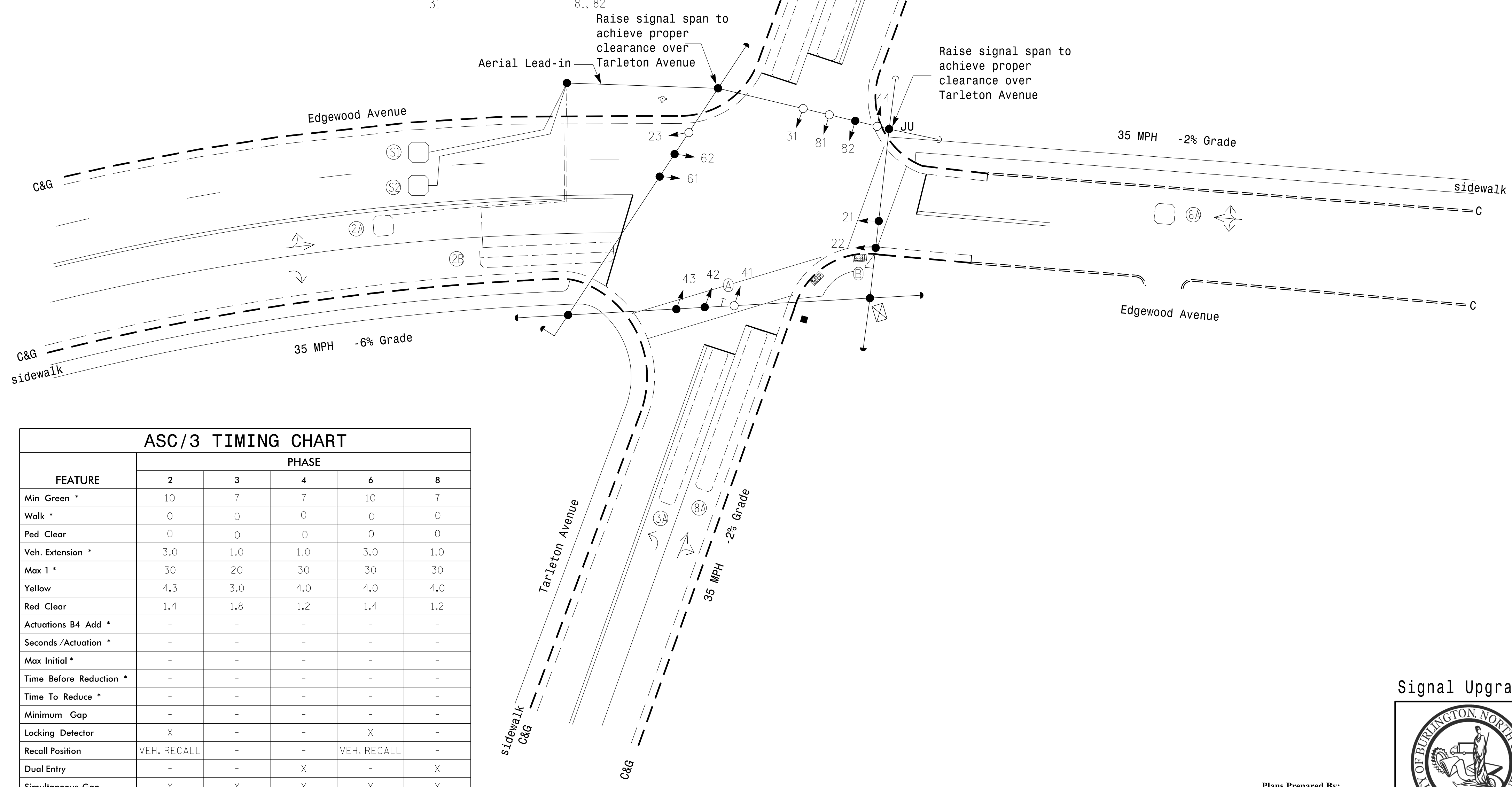

ASC/3 TIMING CHART

FEATURE	PHASE				
	2	3	4	6	8
Min Green *	10	7	7	10	7
Walk *	0	0	0	0	0
Ped Clear	0	0	0	0	0
Veh. Extension *	3.0	1.0	1.0	3.0	1.0
Max 1 *	30	20	30	30	30
Yellow	4.3	3.0	4.0	4.0	4.0
Red Clear	1.4	1.8	1.2	1.4	1.2
Actuations B4 Add *	-	-	-	-	-
Seconds /Actuation *	-	-	-	-	-
Max Initial *	-	-	-	-	-
Time Before Reduction *	-	-	-	-	-
Time To Reduce *	-	-	-	-	-
Minimum Gap	-	-	-	-	-
Locking Detector	X	-	-	X	-
Recall Position	VEH. RECALL	-	-	VEH. RECALL	-
Dual Entry	-	-	X	-	X
Simultaneous Gap	X	X	X	X	X

* These values may be field adjusted. Do not adjust Min Green and Extension times for phases 2 and 6 lower than what is shown. Min Green for all other phases should not be lower than 4 seconds.

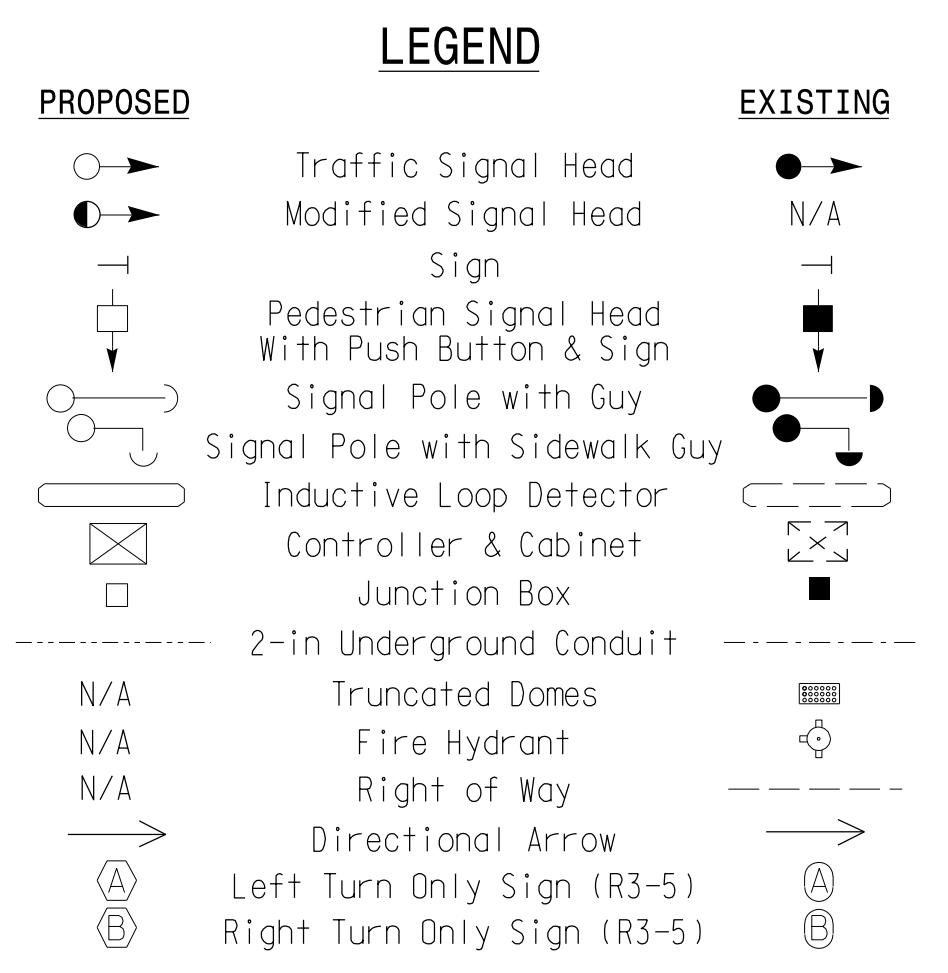

Signal Upgrade

DOCUMENT NOT CONSIDERED FINAL UNLESS ALL SIGNATURES COMPLETED

Plans Prepared By:
DRMP
DRMP, Inc.
8000 Regency Parkway, Suite 175
Cary, NC 27519
NC License No. C-2213 (919) 650-1038

Edgewood Avenue at Tarleton Avenue

Division 7 Alamance County Burlington

PLAN DATE: November 2017 REVIEWED BY: AJ Davis

PREPARED BY: RD Lawton REVIEWED BY: LM Moon

REVISIONS: _____ INIT: _____ DATE: _____

SCALE: 1" = 20'

SEAL

Lisa M. Moon 6/13/2018

SIGNATURE _____ DATE _____

SIG. INVENTORY NO. B7272

13-JUN-2018 17:59 R:\66015\17\off\c\k\signal\phase\signal\sig\186122.dgn Lawton AT CAR-PLANTON-W7

EDI MODEL 2018EClip-NC CONFLICT MONITOR PROGRAMMING DETAIL

(remove jumpers and set switches as shown)

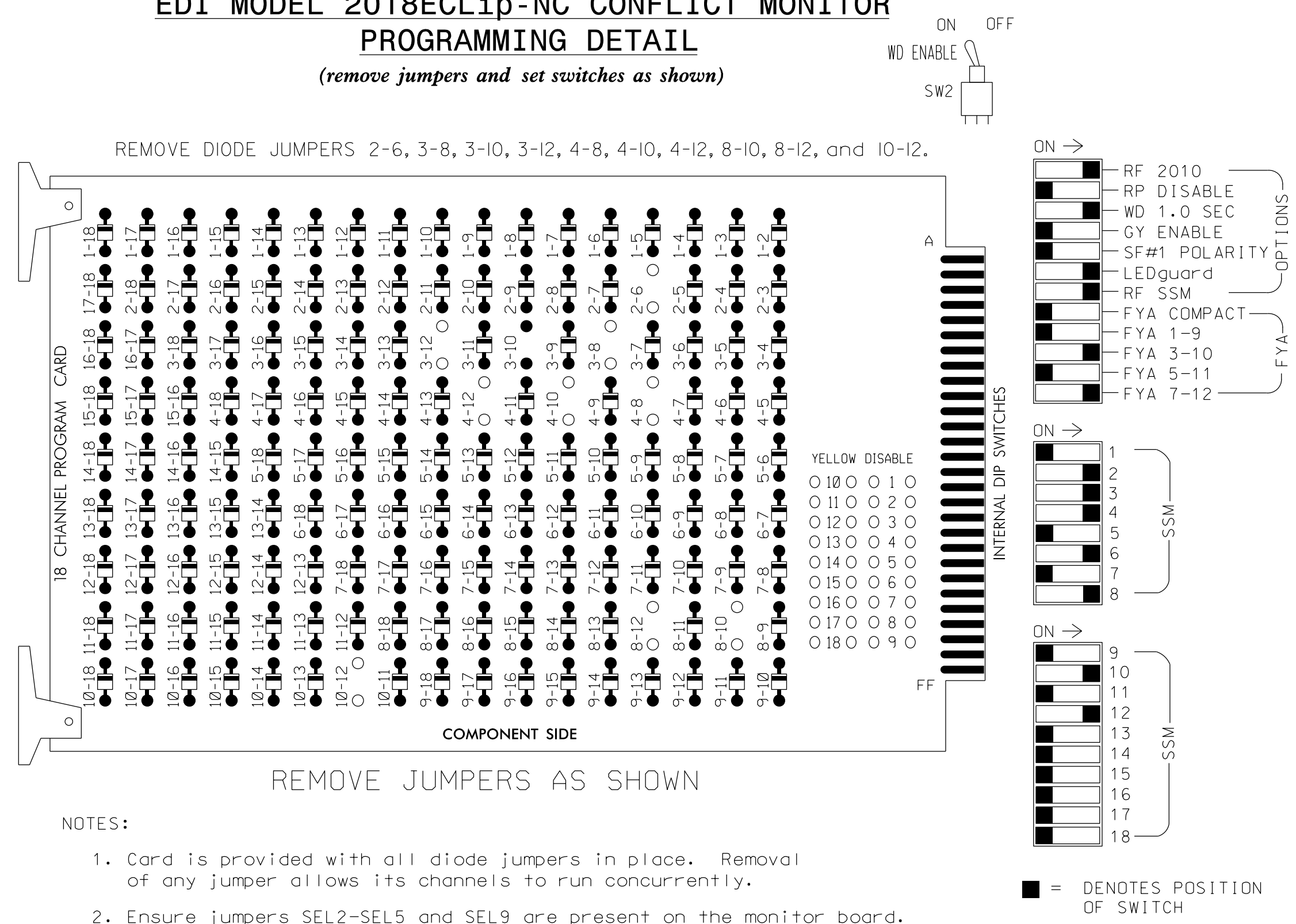

- NOTES:
- Card is provided with all diode jumpers in place. Removal of any jumper allows its channels to run concurrently.
 - Ensure jumpers SEL2-SEL5 and SEL9 are present on the monitor board.
 - Ensure that Red Enable is active at all times during normal operation.
 - Integrate monitor with Ethernet network in cabinet.

NOTES

- To prevent "flash-conflict" problems, insert red flash program blocks for all unused vehicle load switches in the output file. The installer shall verify that signal heads flash in accordance with the Signal Plans.
- Program phases 4 and 8 for Dual Entry.
- Program controller to start up in phase 2 Green and 6 Green.
- The cabinet and controller are part of the Burlington-Graham Signal System.

EQUIPMENT INFORMATION

CONTROLLER.....2070LX
 CABINET.....332 W/AUX
 SOFTWARE.....ECONOLITE ASC/3-2070
 CABINET MOUNT.....BASE
 OUTPUT FILE POSITIONS...18 WITH AUX. OUTPUT FILE LOAD SWITCHES USED.....S2,S4,S5,S8,S11,AUX S2,AUX S5 PHASES USED.....2,3,4,6,8
 OVERLAP "A".....NOT USED
 OVERLAP "B".....*
 OVERLAP "C".....NOT USED
 OVERLAP "D".....*

* See overlap programming detail on sheet 2

SIGNAL HEAD HOOK-UP CHART

LOAD SWITCH NO.	S1	S2	S3	S4	S5	S6	S7	S8	S9	S10	S11	S12	AUX S1	AUX S2	AUX S3	AUX S4	AUX S5	AUX S6	
CMU CHANNEL NO.	1	2	13	3	4	14	5	6	15	7	8	16	9	10	17	11	12	18	
PHASE	1	2	2 PED	3	4	4 PED	5	6	6 PED	7	8	8 PED	OLA	OLB	SPARE	OLC	OLD	SPARE	
SIGNAL HEAD NO.	NU	21,22,23	NU	22	31	42,43,44	NU	NU	61,62	NU	NU	81,82	NU	NU	31	NU	NU	41	NU
RED		128		*		101		134				107							
YELLOW		129				102		135				108							
GREEN		130				103		136				109							
RED ARROW															A124			A101	
YELLOW ARROW															A125			A102	
FLASHING YELLOW ARROW															A126			A103	
GREEN ARROW																			

NU = Not Used
 * Denotes install load resistor. See load resistor installation detail this sheet.
 ★ See pictorial of head wiring in detail this sheet.

INPUT FILE POSITION LAYOUT

(front view)

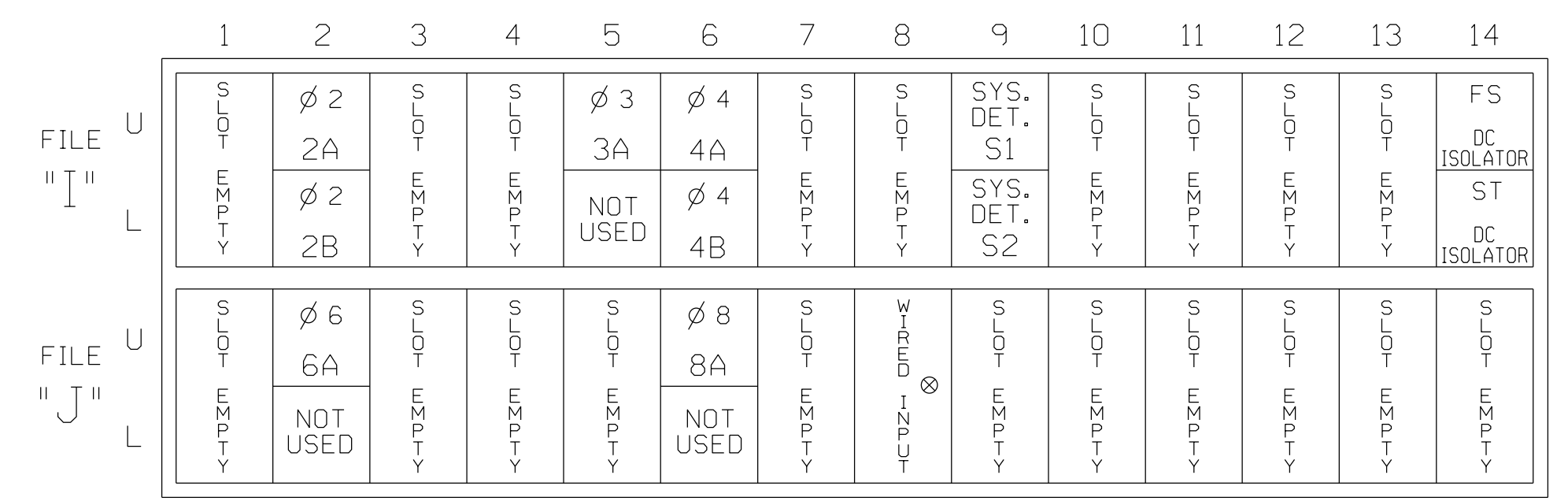

EX.: 1A, 2A, ETC. = LOOP NO.'S
 ⊗ Wired Input - Do not populate slot with detector card

FS = FLASH SENSE
 ST = STOP TIME

INPUT FILE CONNECTION & PROGRAMMING CHART

LOOP NO.	LOOP TERMINAL	INPUT FILE POS.	PIN NO.	DETECTOR NO.	NEMA PHASE	CALL	EXTEND TIME	DELAY TIME	ADDED INITIAL	DETECTOR TYPE
2A	TB2-5,6	I2U	39	2	2	YES				S
2B	TB2-7,8	I2L	43	12	2	YES				S
3A	TB4-5,6	I5U	58	3	3	YES		15		S
		J8U	50	28	8	YES		3		S
4A	TB4-9,10	I6U	41	4	4	YES		3		S
4B	TB4-11,12	I6L	45	14	4	YES		10		S
* S1	TB6-9,10	I9U	60	11	SYS	NO				N
* S2	TB6-11,12	I9L	62	13	SYS	NO				N
6A	TB3-5,6	J2U	40	6	6	YES				S
8A	TB5-9,10	J6U	42	8	8	YES		10		S

* System detector only. Remove any assigned vehicle phase.

^ Add jumper from I5-W to J8-W, on rear of input file.

INPUT FILE POSITION LEGEND: J2L

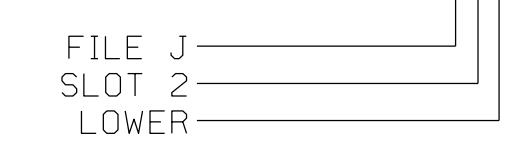

FYA SIGNAL WIRING DETAIL

(wire signal heads as shown)

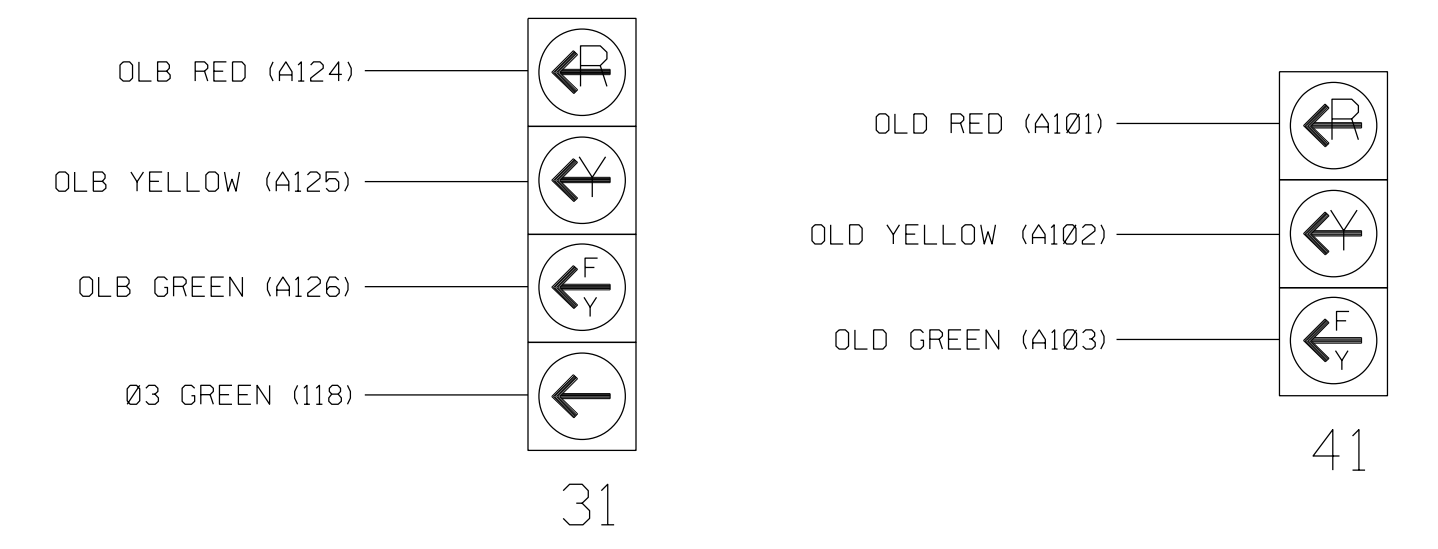

THIS ELECTRICAL DETAIL IS FOR THE SIGNAL DESIGN: B7272
 DESIGNED: NOVEMBER 2017
 SEALED: 06-13-2018
 REVISED: N/A

LOAD RESISTOR INSTALLATION DETAIL

(install resistors as shown)

VALUE (ohms)	WATTAGE
1.5K - 1.9K	25W (min)
2.0K - 3.0K	10W (min)

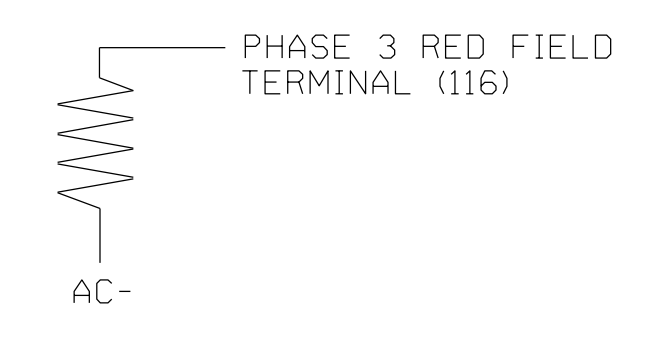

Electrical Detail - Sheet 1 of 2

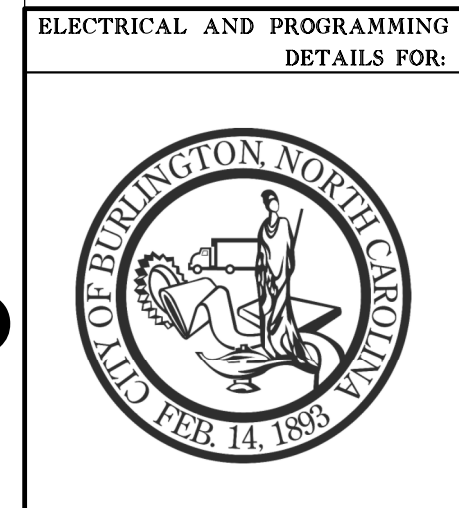

Edgewood Avenue at Tarleton Avenue
 Division 7 Alamance County Burlington
 PLAN DATE: November 2017 REVIEWED BY: AJ Davis
 PREPARED BY: RD Lawton REVIEWED BY: LM Moon

DOCUMENT NOT CONSIDERED FINAL UNLESS ALL SIGNATURES COMPLETED

DocuSigned by: Lisa M. Moon 6/13/2018
 SIGNED: 6/13/2018
 SIG. INVENTORY NO. B7272



ECONOLITE ASC/3-2070 OVERLAP PROGRAMMING DETAIL (program controller as shown)

- From Main Menu select **2. CONTROLLER**
- From CONTROLLER Submenu select **2. VEHICLE OVERLAPS**
Toggle Once

OVERLAP B

Select TMG VEH OVLP [B] and 'PPLT FYA'

```

TMG VEH OVLP...[B] TYPE: ....[PPLT FYA]
PROTECTED LEFT TURN.... PHASE 3
OPPOSING THROUGH..... PHASE 4

FLASHING ARROW OUTPUT....CH10 ISOLATE
DELAY START OF: FYA..0.0 CLEARANCE..0.0
ACTION PLAN SF BIT DISABLE..... 0

```

Toggle Twice

OVERLAP D

Select TMG VEH OVLP [D] and 'OTHER/ECONOLITE'

```

TMG VEH OVLP...[D] TYPE:[OTHER/ECONOLITE]
PHASES 1 2 3 4 5 6 7 8 9 0 1 2 3 4 5 6
INCLUDED . . . . . X . . . . .
PROTECT . . . . .
PED PRTC . . . . .
NOT OVLP . . . . .
FLSH GRN . . . . . 1 . . . . .
LAG X PH . . . . .
LAG 2 PH . . . . .

LAG GRN 0.0 YEL 0.0 RED 0.0 ADV GRN 0.0

```

END PROGRAMMING

FLASHER CIRCUIT MODIFICATION DETAIL

In order to ensure that signals flash concurrently on the same approach, make the following flasher circuit changes:

- On rear of PDA - remove wire from Term. T2-4 and terminate on T2-2.
- On rear of PDA - remove wire from Term. T2-5 and terminate on T2-3.
- Remove flasher unit 2.

The changes listed above ties all phases and overlaps to flasher unit 1.

THIS ELECTRICAL DETAIL IS FOR
 THE SIGNAL DESIGN: B7272
 DESIGNED: NOVEMBER 2017
 SEALED: 06-13-2018
 REVISED: N/A

Electrical Detail - Sheet 2 of 2

DOCUMENT NOT CONSIDERED FINAL UNLESS ALL SIGNATURES COMPLETED

ELECTRICAL AND PROGRAMMING DETAILS FOR:

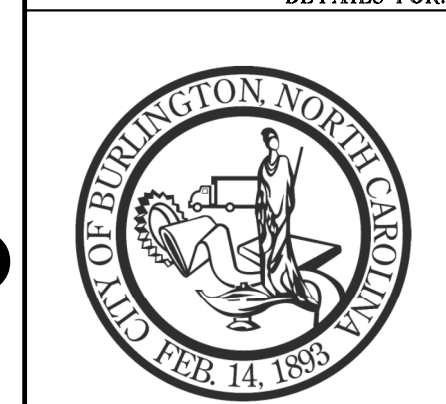

Edgewood Avenue
at
Tarleton Avenue

Division 7 Alamance County Burlington

PLAN DATE: November 2017 REVIEWED BY: AJ Davis

PREPARED BY: RD Lawton REVIEWED BY: LM Moon

REVISIONS	INIT.	DATE



DocuSigned by:
Lisa M. Moon
6/13/2018
DATE
SIG. INVENTORY NO. B7272



13-JUN-2018 1:00 PM
R:\66015\17\offices\esignals\design\wlr\img\B7272a.dgn
Lawton AT CAR-RLAWTON-W7

EDI MODEL 2018ECLip-NC CONFLICT MONITOR PROGRAMMING DETAIL

(remove jumpers and set switches as shown)

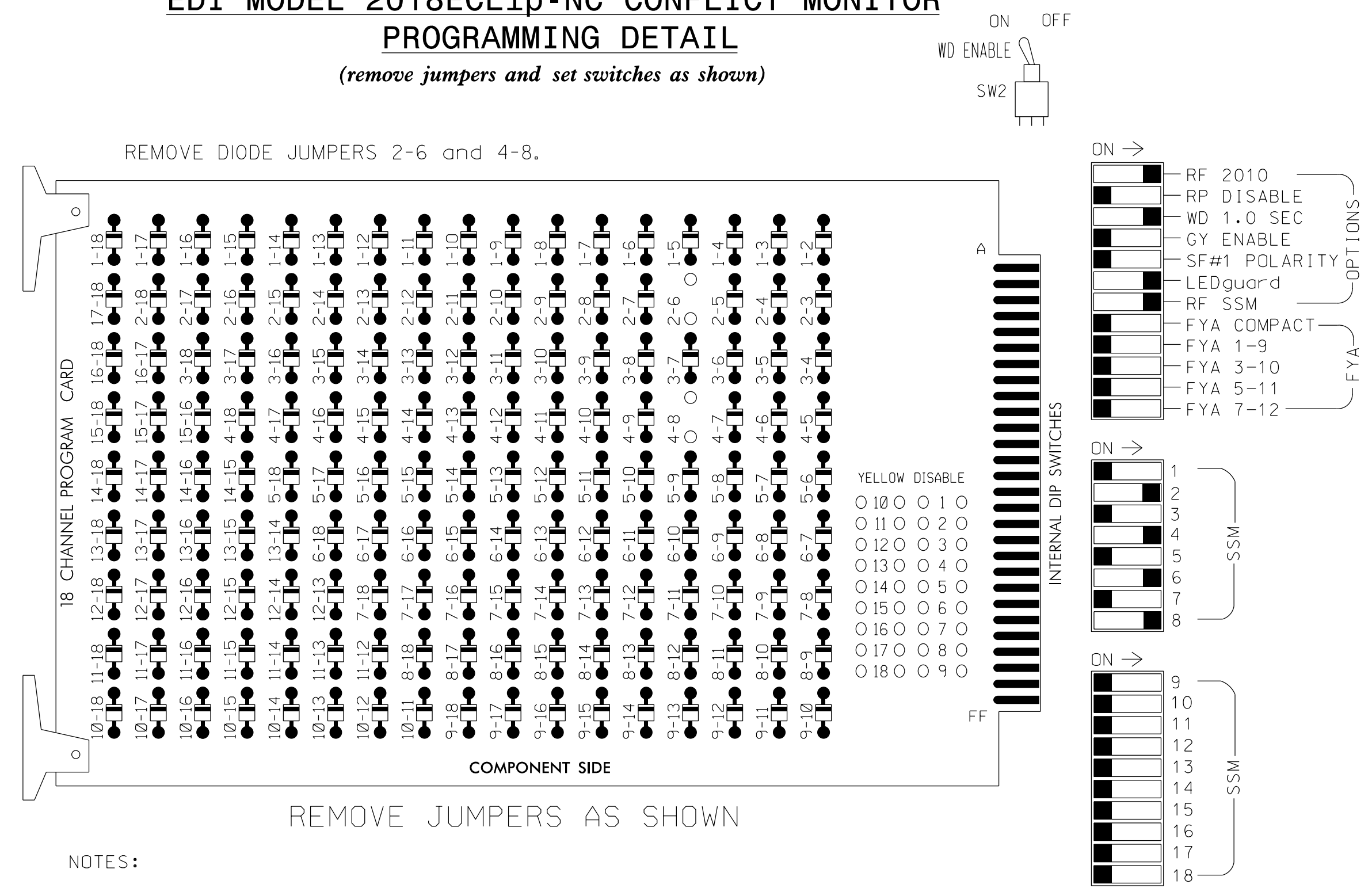

- NOTES:
- Card is provided with all diode jumpers in place. Removal of any jumper allows its channels to run concurrently.
 - Ensure jumpers SEL2-SEL5 and SEL9 are present on the monitor board.
 - Ensure that Red Enable is active at all times during normal operation.
 - Integrate monitor with Ethernet network in cabinet.

NOTES

- To prevent "flash-conflict" problems, insert red flash program blocks for all unused vehicle load switches in the output file. The installer shall verify that signal heads flash in accordance with the Signal Plans.
- Program phases 4 and 8 for Dual Entry.
- Program controller to start up in phase 2 Green and 6 Green.
- The cabinet and controller are part of the Burlington-Graham Signal System.

EQUIPMENT INFORMATION

CONTROLLER.....2070LX
 CABINET.....332
 SOFTWARE.....ECONOLITE ASC/3-2070
 CABINET MOUNT.....BASE
 OUTPUT FILE POSITIONS...18 WITH AUX. OUTPUT FILE LOAD SWITCHES USED.....S2,S5,S8,S11
 PHASES USED.....2,4,6,8
 OVERLAP 'A'.....NOT USED
 OVERLAP 'B'.....NOT USED
 OVERLAP 'C'.....NOT USED
 OVERLAP 'D'.....NOT USED

SIGNAL HEAD HOOK-UP CHART

LOAD SWITCH NO.	S1	S2	S3	S4	S5	S6	S7	S8	S9	S10	S11	S12	AUX S1	AUX S2	AUX S3	AUX S4	AUX S5	AUX S6
CMU CHANNEL NO.	1	2	13	3	4	14	5	6	15	7	8	16	9	10	17	11	12	18
PHASE	1	2	PED	3	4	PED	5	6	PED	7	8	PED	OLA	OLB	SPARE	OLC	OLD	SPARE
SIGNAL HEAD NO.	NU	21,22	NU	NU	41,42	NU	NU	61,62	NU	NU	81,82	NU	NU	NU	NU	NU	NU	NU
RED		128			101			134			107							
YELLOW		129			102			135			108							
GREEN		130			103			136			109							
RED ARROW																		
YELLOW ARROW																		
FLASHING YELLOW ARROW																		
GREEN ARROW																		

NU = Not Used

INPUT FILE POSITION LAYOUT

(front view)

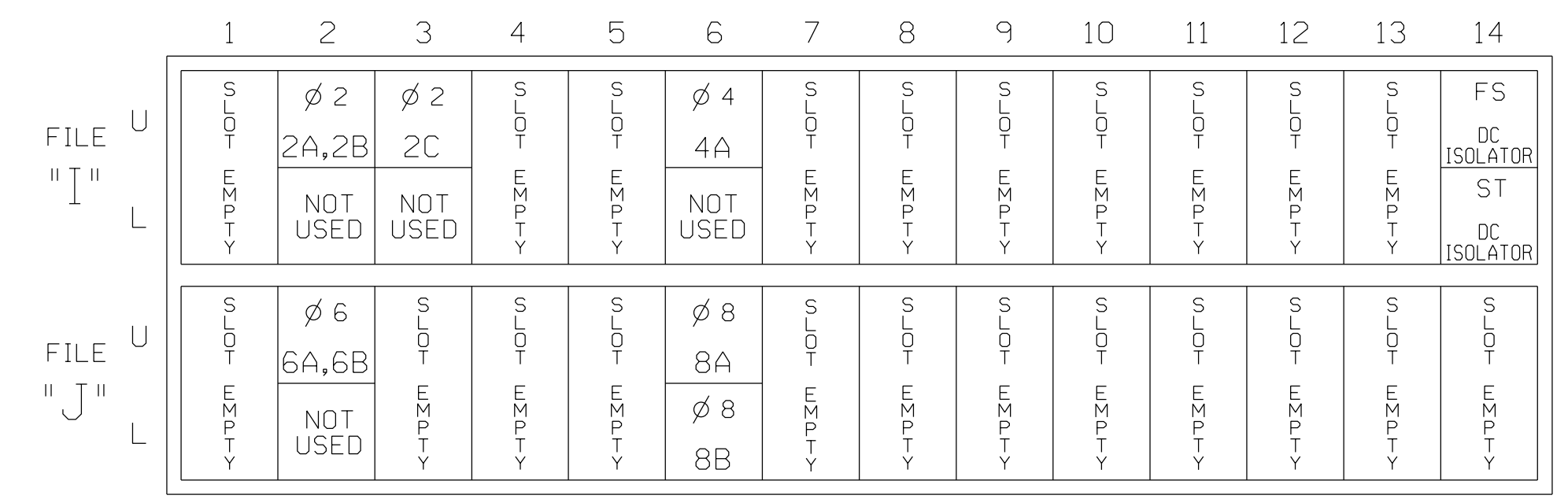

EX.: 1A, 2A, ETC. = LOOP NO.'S

FS = FLASH SENSE
 ST = STOP TIME

INPUT FILE CONNECTION & PROGRAMMING CHART

LOOP NO.	LOOP TERMINAL	INPUT FILE POS.	PIN NO.	DETECTOR NO.	NEMA PHASE	CALL	EXTEND TIME	DELAY TIME	ADDED INITIAL	DETECTOR TYPE
2A,2B	TB2-5,6	I2U	39	2	2	YES				S
2C	TB2-9,10	I3U	63	32	2	YES				S
4A	TB4-9,10	I6U	41	4	4	YES		3		S
6A,6B	TB3-5,6	J2U	40	6	6	YES				S
8A	TB5-9,10	J6U	42	8	8	YES				S
8B	TB5-11,12	J6L	46	18	8	YES		10		S

INPUT FILE POSITION LEGEND: J2L

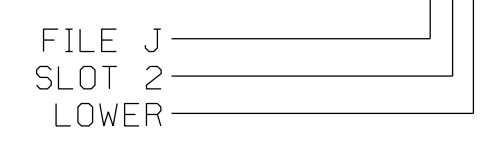

THIS ELECTRICAL DETAIL IS FOR THE SIGNAL DESIGN: B-7273
 DESIGNED: December 2017
 SEALED: 6/9/2018
 REVISED: N/A

11-JUN-2018 17:13 D:\transortat\om\Facility\cur\10056469 U-6015 B-G S1g Sys\Task 05_11_Signal\Des\gmr\In\gB-7273E.dgn ALEX3361 AT LUS510649

Electrical Detail

ELECTRICAL AND PROGRAMMING DETAILS FOR:

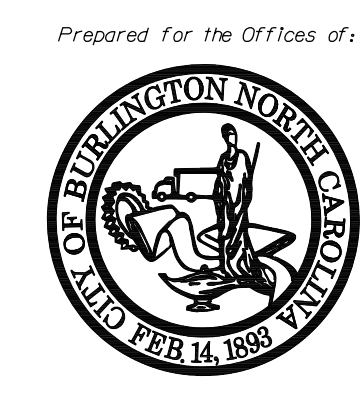

Prepared for the Offices of:

Edgewood Avenue at Hermitage Road/Turrentine School Access

Division 7 Alamance County Burlington

PLAN DATE: December 2017 REVIEWED BY: AM Encarnacion

PREPARED BY: VJ Paul REVIEWED BY: PL Alexander

REVISIONS	INIT.	DATE

DOCUMENT NOT CONSIDERED FINAL UNLESS ALL SIGNATURES COMPLETED

SEAL
 NORTH CAROLINA PROFESSIONAL ENGINEER
 PAMELA L. ALEXANDER
 SEAL 023489
 DATE 6/11/2018
 Signature: Pamela Alexander
 DATE: 6/11/2018
 SIG. INVENTORY NO. B-7273

EDI MODEL 2018ECLIP-NC CONFLICT MONITOR PROGRAMMING DETAIL

(remove jumpers and set switches as shown)

REMOVE DIODE JUMPERS 1-6, 1-9, 1-11, 2-6, 2-9, 2-11, 6-9, 6-11, and 9-11.

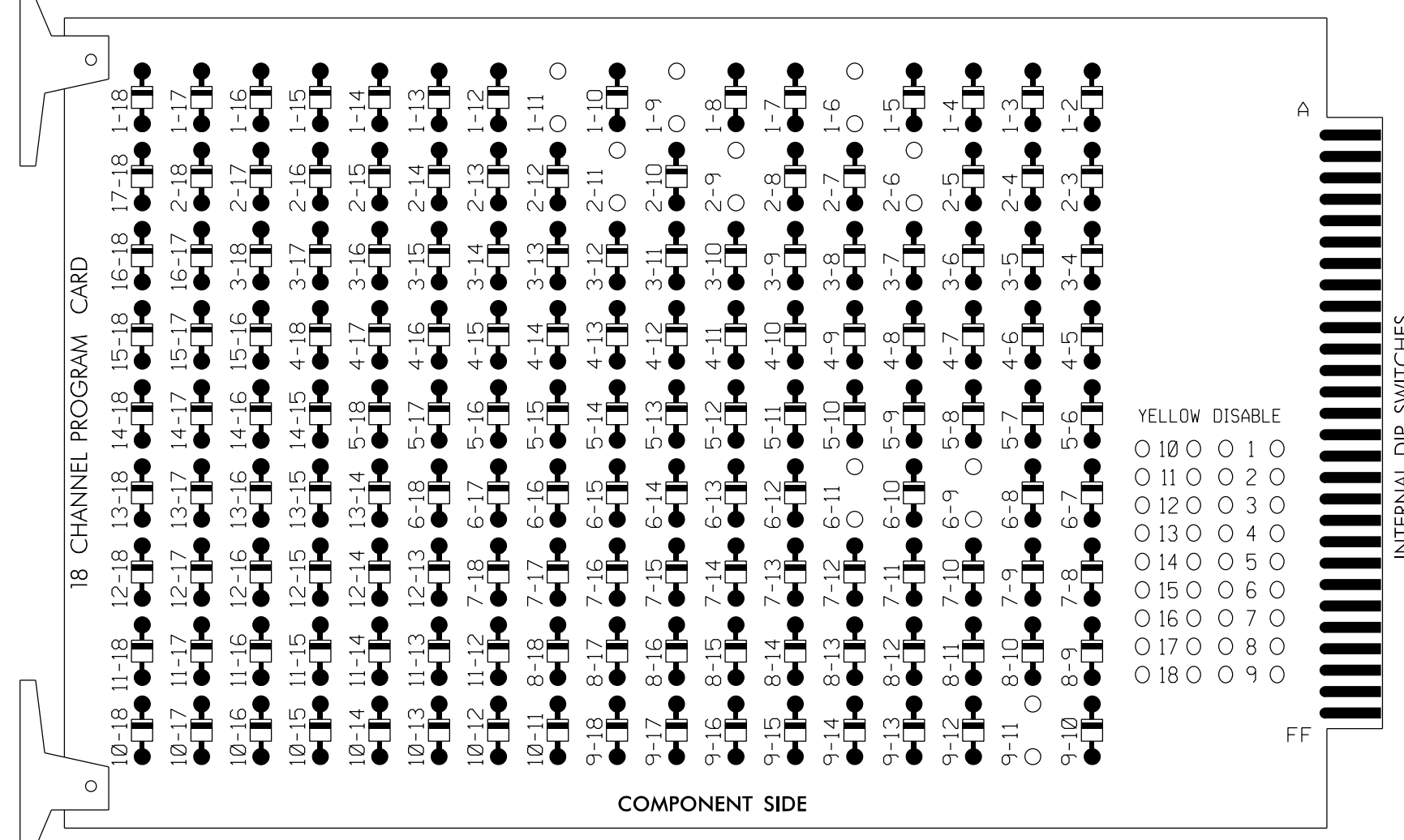

REMOVE JUMPERS AS SHOWN

NOTES:

- Card is provided with all diode jumpers in place. Removal of any jumper allows its channels to run concurrently.
- Ensure jumpers SEL2-SEL5 and SEL9 are present on the monitor board.
- Ensure that Red Enable is active at all times during normal operation.
- Integrate monitor with Ethernet network in cabinet.

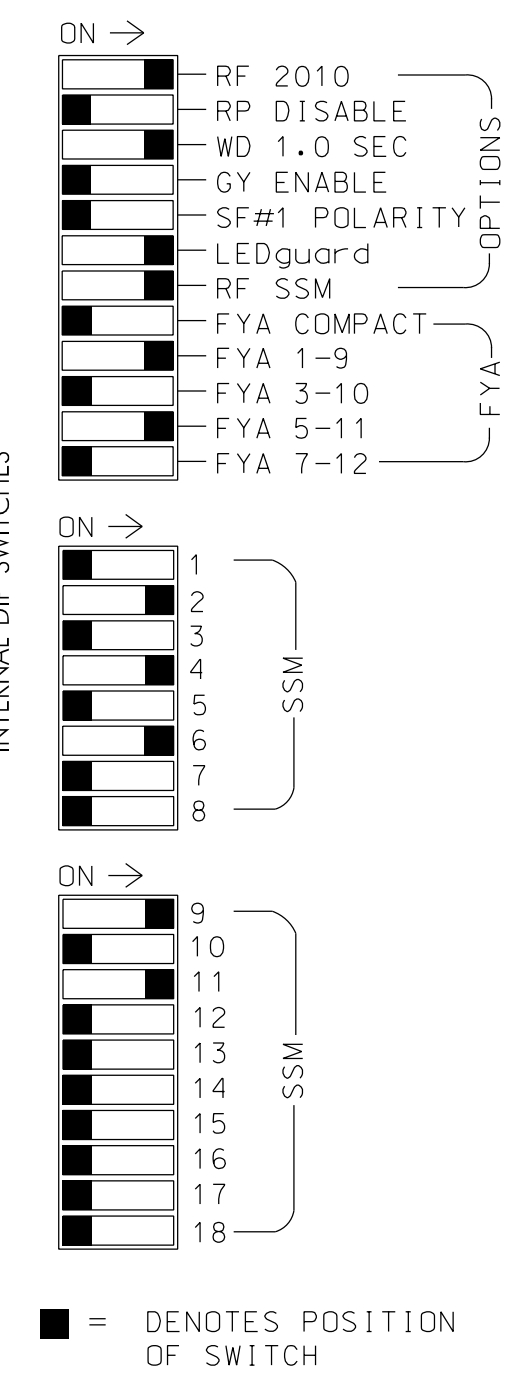
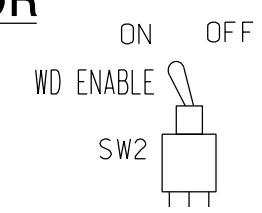

NOTES

- To prevent "flash-conflict" problems, insert red flash program blocks for all unused vehicle load switches in the output file. The installer shall verify that signal heads flash in accordance with the Signal Plans.
- Program controller to start up in phase 2 Green and 6 Green.
- The cabinet and controller are part of the Burlington-Graham Signal System.

EQUIPMENT INFORMATION

CONTROLLER.....2070LX
 CABINET.....332 W/AUX
 SOFTWARE.....ECONDLITE ASC/3-2070
 CABINET MOUNT.....BASE
 OUTPUT FILE POSITIONS...18 WITH AUX. OUTPUT FILE
 LOAD SWITCHES USED.....S1,S2,S5,S8,AUX S1,AUX S4
 PHASES USED.....1,2,4,6
 OVERLAP "A".....*
 OVERLAP "B".....NOT USED
 OVERLAP "C".....*
 OVERLAP "D".....NOT USED

* See overlap programming detail on sheet 2

PROJECT REFERENCE NO.	SHEET NO.
U-6015	Sig.188.1

SIGNAL HEAD HOOK-UP CHART

LOAD SWITCH NO.	S1	S2	S3	S4	S5	S6	S7	S8	S9	S10	S11	S12	AUX S1	AUX S2	AUX S3	AUX S4	AUX S5	AUX S6
CMU CHANNEL NO.	1	2	13	3	4	14	5	6	15	7	8	16	9	10	17	11	12	18
PHASE	1	2	2 PED	3	4	4 PED	5	6	6 PED	7	8	8 PED	OLA	OLB	SPARE	OLC	OLD	SPARE
SIGNAL HEAD NO.	11	22,23	NU	NU	41,42	NU	NU	61,62	NU	NU	NU	NU	11	NU	NU	21	NU	NU
RED		128			101			134										
YELLOW	*	129			102			135										
GREEN		130			103			136										
RED ARROW													A121				A114	
YELLOW ARROW													A122				A115	
FLASHING YELLOW ARROW													A123				A116	
GREEN ARROW	127																	

NU = Not Used

* Denotes install load resistor. See load resistor installation detail this sheet.

★ See pictorial of head wiring in detail this sheet.

INPUT FILE POSITION LAYOUT

(front view)

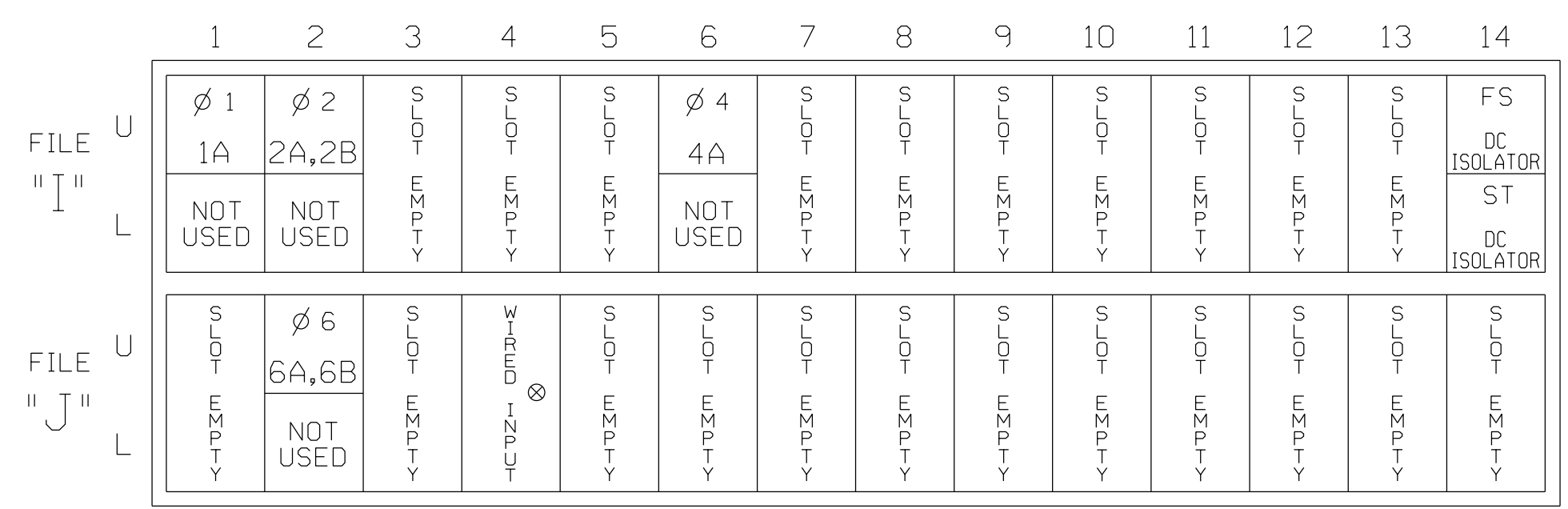

EX.: 1A, 2A, ETC. = LOOP NO.'S

FS = FLASH SENSE
 ST = STOP TIME

⊗ Wired Input - Do not populate slot with detector card

INPUT FILE CONNECTION & PROGRAMMING CHART

LOOP NO.	LOOP TERMINAL	INPUT FILE POS.	PIN NO.	DETECTOR NO.	NEMA PHASE	CALL	EXTEND TIME	DELAY TIME	ADDED INITIAL	DETECTOR TYPE
1A ¹	TB2-1,2	I1U	56	1	1	YES		15		S
	-	J4U	48	26	6	YES				S
2A,2B	TB2-5,6	I2U	39	2	2	YES				S
4A	TB4-9,10	I6U	41	4	4	YES		5		S
6A,6B	TB3-5,6	J2U	40	6	6	YES				S

¹Add jumper from I1-W to J4-W, on rear of input file.

INPUT FILE POSITION LEGEND: J2L

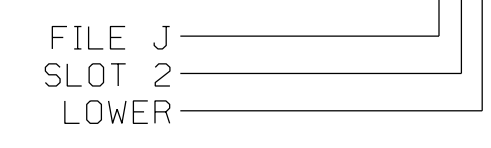

FYA SIGNAL WIRING DETAIL

(wire signal heads as shown)

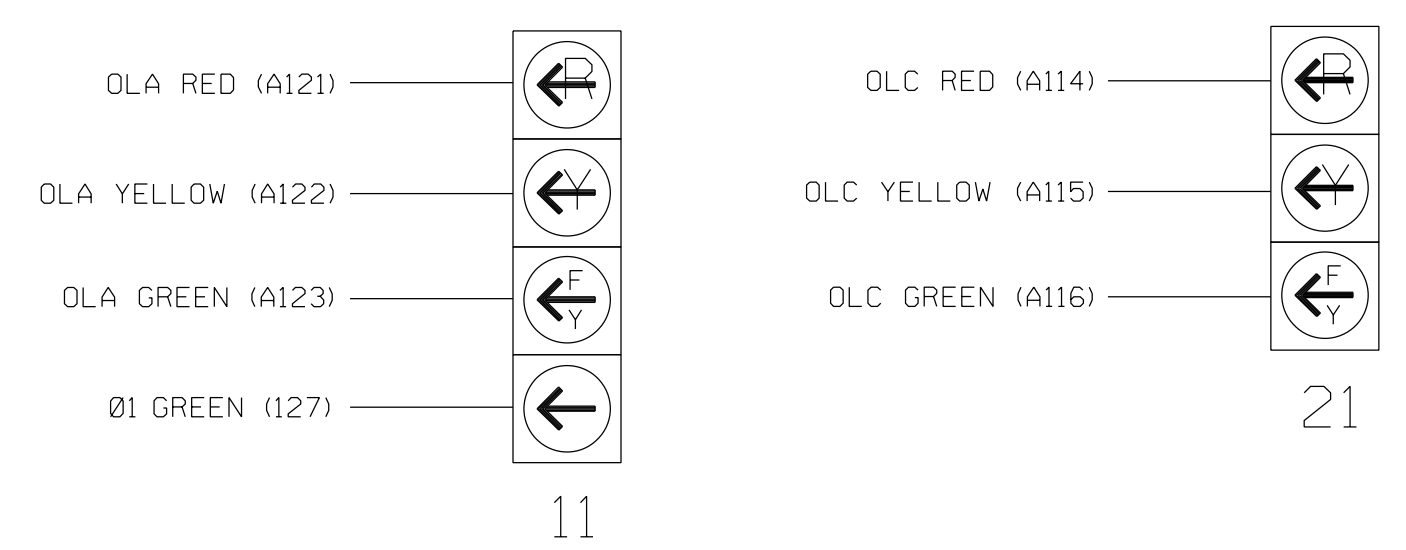

LOAD RESISTOR INSTALLATION DETAIL

(install resistor as shown)

VALUE (ohms)	WATTAGE
1.5K - 1.9K	25W (min)
2.0K - 3.0K	10W (min)

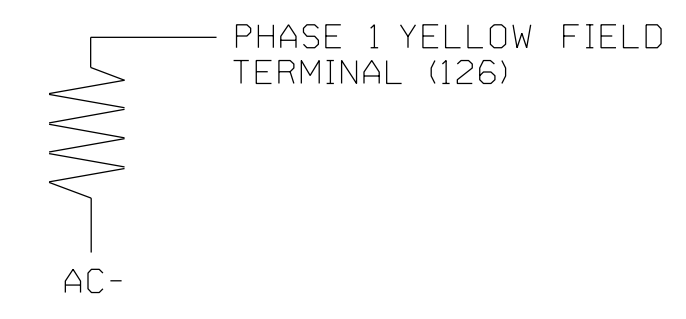

Electrical Detail - Sheet 1 of 2

ELECTRICAL AND PROGRAMMING DETAILS FOR: Prepared for the Offices of: 	Edgewood Avenue at Turrentine School Access/ Medical Building Access		SEAL NORTH CAROLINA PROFESSIONAL ENGINEER PAMELA L. ALEXANDER SEAL 023489
	Division 7 Alamance County Burlington PLAN DATE: November 2017 REVIEWED BY: AM Encarnacion PREPARED BY: VJ Paul REVIEWED BY: PL Alexander	REVISIONS INIT. DATE _____ _____	
THIS ELECTRICAL DETAIL IS FOR THE SIGNAL DESIGN: B-7274 DESIGNED: November 2017 SEALED: 6/9/2018 REVISED: N/A			SEAL PAMELA L. ALEXANDER 6/11/2018 DATE _____ _____ SIG. INVENTORY NO. B-7274

ECONOLITE ASC/3-2070 OVERLAP PROGRAMMING DETAIL

(program controller as shown)

1. From Main Menu select 2. CONTROLLER
2. From CONTROLLER Submenu select 2. VEHICLE OVERLAPS

OVERLAP A

Select TMG VEH OVLP [A] and 'PPLT FYA'

TMG VEH OVLP...[A] TYPE:PPLT FYA

PROTECTED LEFT TURN.... PHASE 1

OPPOSING THROUGH..... PHASE 2

FLASHING ARROW OUTPUT.....CH9 ISOLATE

DELAY START OF: FYA..0.0 CLEARANCE..0.0

ACTION PLAN SF BIT DISABLE..... 0

↓ Toggle Twice

OVERLAP C

Select TMG VEH OVLP [C] and 'OTHER/ECONOLITE'

TMG VEH OVLP...[C] TYPE:OTHER/ECONOLITE

PHASES 1 2 3 4 5 6 7 8 9 0 1 2 3 4 5 6

INCLUDED X

PROTECT

PED PRTC

NOT OVLP

FLSH GRN 1

LAG X PH

LAG 2 PH

LAG GRN 0.0 YEL 0.0 RED 0.0 ADV GRN 0.0

END PROGRAMMING

THIS ELECTRICAL DETAIL IS FOR
 THE SIGNAL DESIGN: B-7274
 DESIGNED: November 2017
 SEALED: 6/9/2018
 REVISED: N/A

11-JUN-2018 17:13
 D:\Consort\Tat\on\Facility\Cur\100056469 U-6015 B-G S1g Sys\Task 05_11_Signal\Des\gr\wlr\Inq\B-7274E.dgn
 ALEX3361 AT LUS310649

Electrical Detail - Sheet 2 of 2

DOCUMENT NOT CONSIDERED
FINAL UNLESS ALL
SIGNATURES COMPLETED

ELECTRICAL AND PROGRAMMING DETAILS FOR: Prepared for the Offices of: 	Edgewood Avenue at Turrentine School Access/ Medical Building Access	SEAL
Division 7 Alamance County Burlington	PLAN DATE: November 2017 REVIEWED BY: AM Encarnacion	PREPARED BY: VJ Paul REVIEWED BY: PL Alexander
REVISIONS INIT. DATE	Prepared by: <u>Pamela Alexander</u> 6/11/2018 DATE	
SIG. INVENTORY NO. B-7274		

EDI MODEL 2018ECLip-NC CONFLICT MONITOR PROGRAMMING DETAIL

(remove jumpers and set switches as shown)

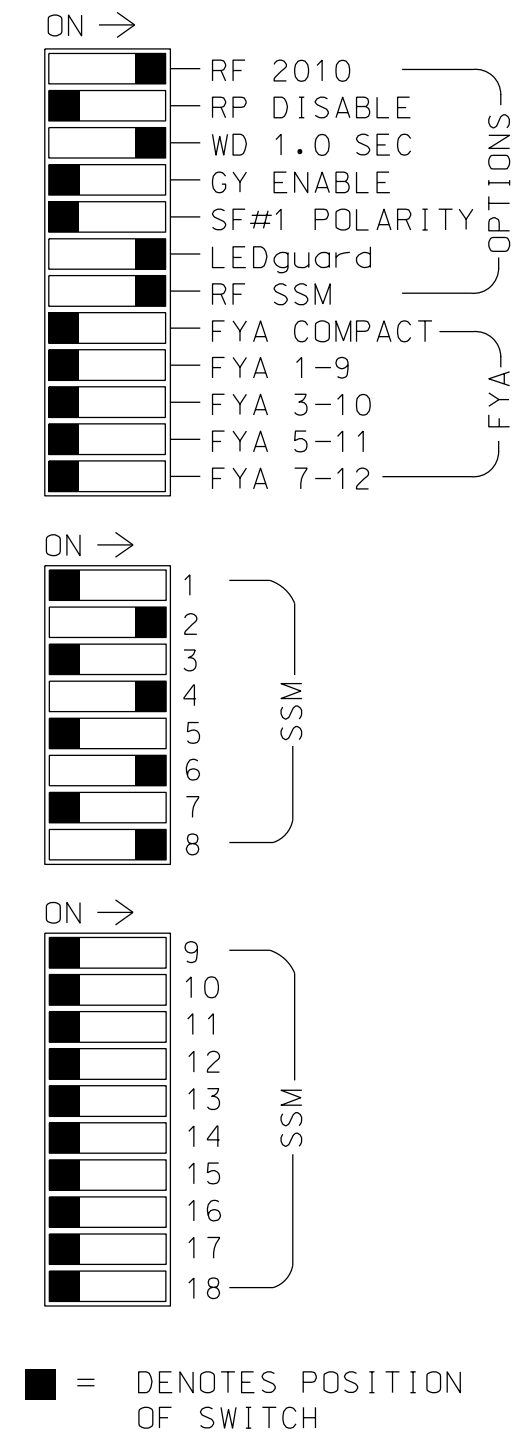
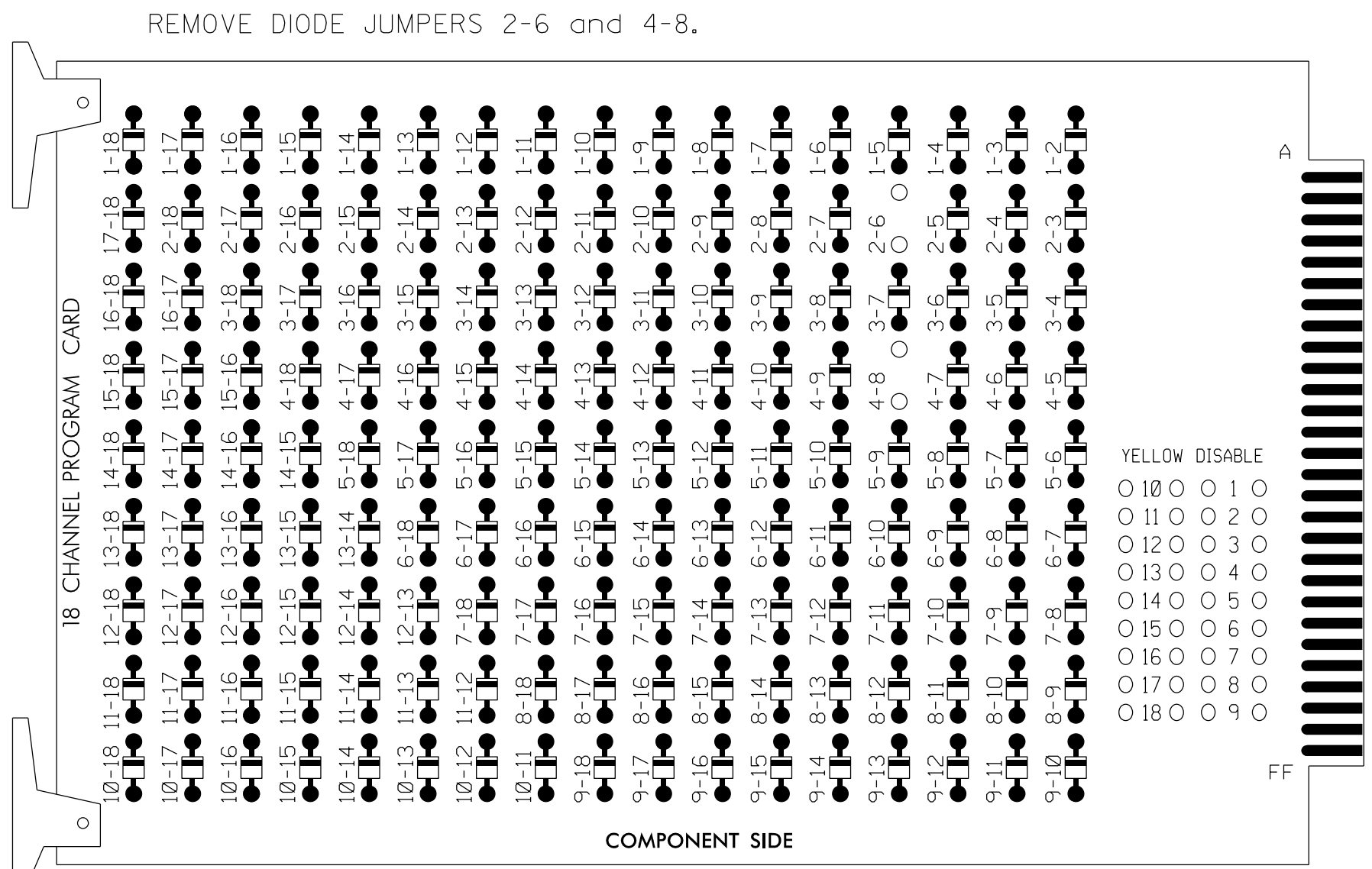
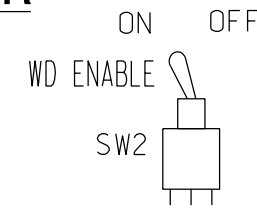

NOTES:

1. Card is provided with all diode jumpers in place. Removal of any jumper allows its channels to run concurrently.
2. Ensure jumpers SEL2-SEL5 and SEL9 are present on the monitor board.
3. Ensure that Red Enable is active at all times during normal operation.
4. Integrate monitor with Ethernet network in cabinet.

NOTES

1. To prevent "flash-conflict" problems, insert red flash program blocks for all unused vehicle load switches in the output file. The installer shall verify that signal heads flash in accordance with the Signal Plans.
2. Program controller to start up in phase 2 Green and 6 Green.
3. The cabinet and controller are part of the Burlington-Graham Signal System.

SIGNAL HEAD HOOK-UP CHART

LOAD SWITCH NO.	S1	S2	S3	S4	S5	S6	S7	S8	S9	S10	S11	S12
CMU CHANNEL NO.	1	2	13	3	4	14	5	6	15	7	8	16
PHASE	1	2	2 PED	3	4	4 PED	5	6	6 PED	7	8	8 PED
SIGNAL HEAD NO.	NU	21,22	NU	NU	41,42	NU	NU	61,62	NU	NU	81,82	NU
RED		128			101			134			107	
YELLOW		129			102			135			108	
GREEN		130			103			136			109	
RED ARROW												
YELLOW ARROW												
GREEN ARROW												

NU = Not Used

EQUIPMENT INFORMATION

CONTROLLER.....2070LX
 CABINET.....336
 SOFTWARE.....ECONDLITE ASC/3-2070
 CABINET MOUNT.....POLE
 OUTPUT FILE POSITIONS...12
 LOAD SWITCHES USED.....S2,S5,S8,S11
 PHASES USED.....2,4,6,8
 OVERLAPS.....NONE

INPUT FILE POSITION LAYOUT

(front view)

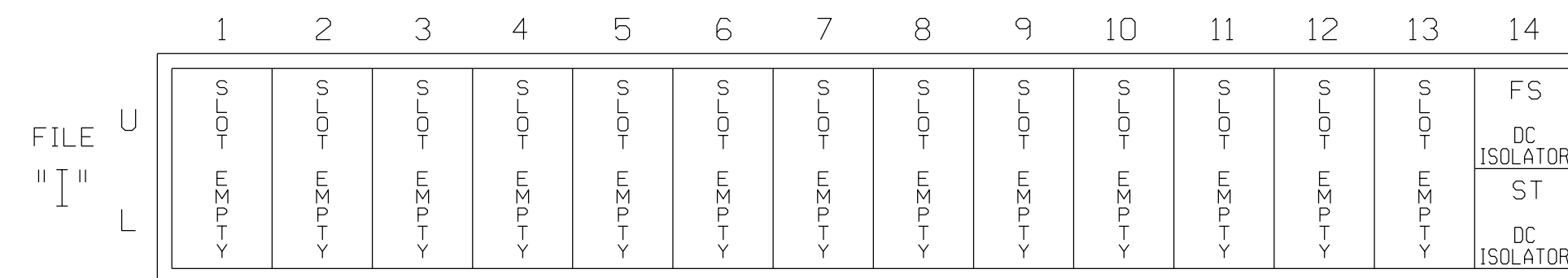

EX.: 1A, 2A, ETC. = LOOP NO.'S

FS = FLASH SENSE
 ST = STOP TIME

Electrical Detail

ELECTRICAL AND PROGRAMMING DETAILS FOR:



Maple Avenue
at
S. Broad Street

Division 7	Alamance County	Burlington
PLAN DATE: January 2018	REVIEWED BY: AJ Davis	
PREPARED BY: DJ White	REVIEWED BY: LM Moon	
REVISIONS	INIT.	DATE

DOCUMENT NOT CONSIDERED FINAL UNLESS ALL SIGNATURES COMPLETED

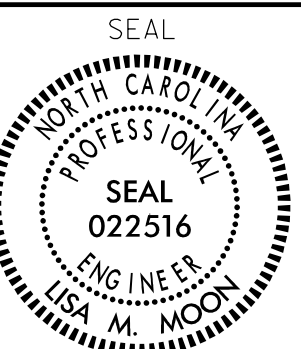

DocuSigned by:
Lisa M. Moon
6/13/2018
SIC. INVENTORY NO. B8022

EDI MODEL 2018EClip-NC CONFLICT MONITOR PROGRAMMING DETAIL

(remove jumpers and set switches as shown)

REMOVE DIODE JUMPERS 1-5, 1-6, 1-9, 1-11, 2-5, 2-6, 2-9, 2-11, 4-8, 5-9, 5-11, 6-9, 6-11 and 9-11.

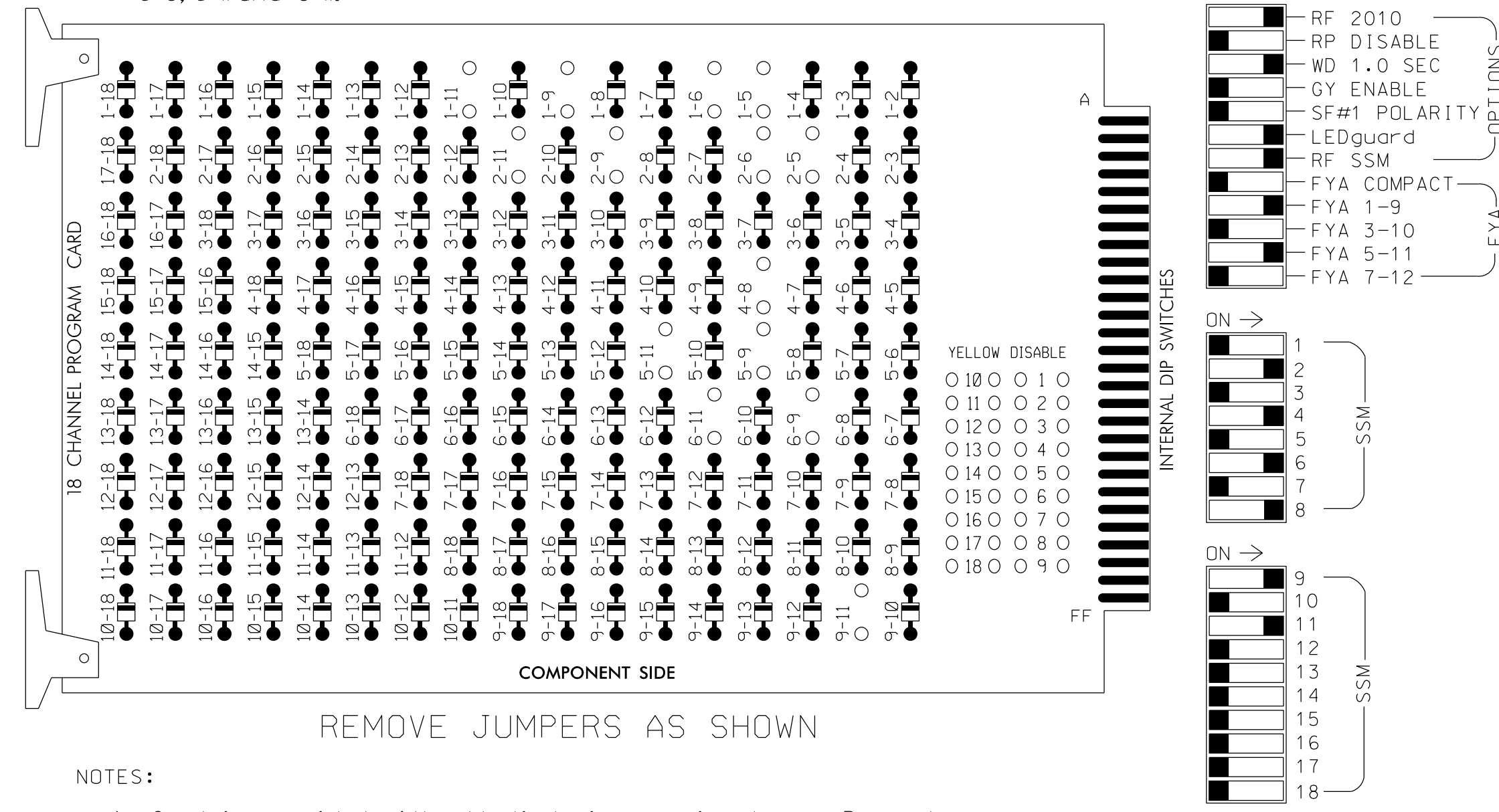

NOTES:

- Card is provided with all diode jumpers in place. Removal of any jumper allows its channels to run concurrently.
- Ensure jumpers SEL2-SEL5 and SEL9 are present on the monitor board.
- Ensure that Red Enable is active at all times during normal operation.
- Integrate monitor with Ethernet network in cabinet.

NOTES

- To prevent "flash-conflict" problems, insert red flash program blocks for all unused vehicle load switches in the output file. The installer shall verify that signal heads flash in accordance with the Signal Plans.
- Program phases 4 and 8 for Dual Entry.
- Program controller to start up in phase 2 Green and 6 Green.
- The cabinet and controller are part of the Burlington-Graham Signal System.

EQUIPMENT INFORMATION

CONTROLLER.....2070LX
 CABINET.....332 W/AUX
 SOFTWARE.....ECONOLITE ASC/3-2070
 CABINET MOUNT.....BASE
 OUTPUT FILE POSITIONS...18 WITH AUX. OUTPUT FILE
 LOAD SWITCHES USED.....S1,S2,S5,S7,S8,S11,AUX S1,
 AUX S4
 PHASES USED.....1,2,4,5,6,8
 OVERLAP "A".....*
 OVERLAP "B".....NOT USED
 OVERLAP "C".....*
 OVERLAP "D".....NOT USED

* See overlap programming detail on sheet 2

SIGNAL HEAD HOOK-UP CHART

LOAD SWITCH NO.	S1	S2	S3	S4	S5	S6	S7	S8	S9	S10	S11	S12	AUX S1	AUX S2	AUX S3	AUX S4	AUX S5	AUX S6
CNU CHANNEL NO.	1	2	13	3	4	14	5	6	15	7	8	16	9	10	17	11	12	18
PHASE	1	2	2 PED	3	4	4 PED	5	6	6 PED	7	8	8 PED	OLA	OLB	SPARE	OLC	OLD	SPARE
SIGNAL HEAD NO.	11*	21,22	NU	NU	41,42	NU	51*	61,62	NU	NU	81,82	NU	11*	NU	NU	51*	NU	NU
RED		128			101			134			107							
YELLOW	*	129			102		*	135			108							
GREEN		130			103			136			109							
RED ARROW														A121				A114
YELLOW ARROW														A122				A115
FLASHING YELLOW ARROW														A123				A116
GREEN ARROW	127								133									

NU = Not Used

* Denotes install load resistor. See load resistor installation detail this sheet.

★ See pictorial of head wiring in detail this sheet.

INPUT FILE POSITION LAYOUT

(front view)

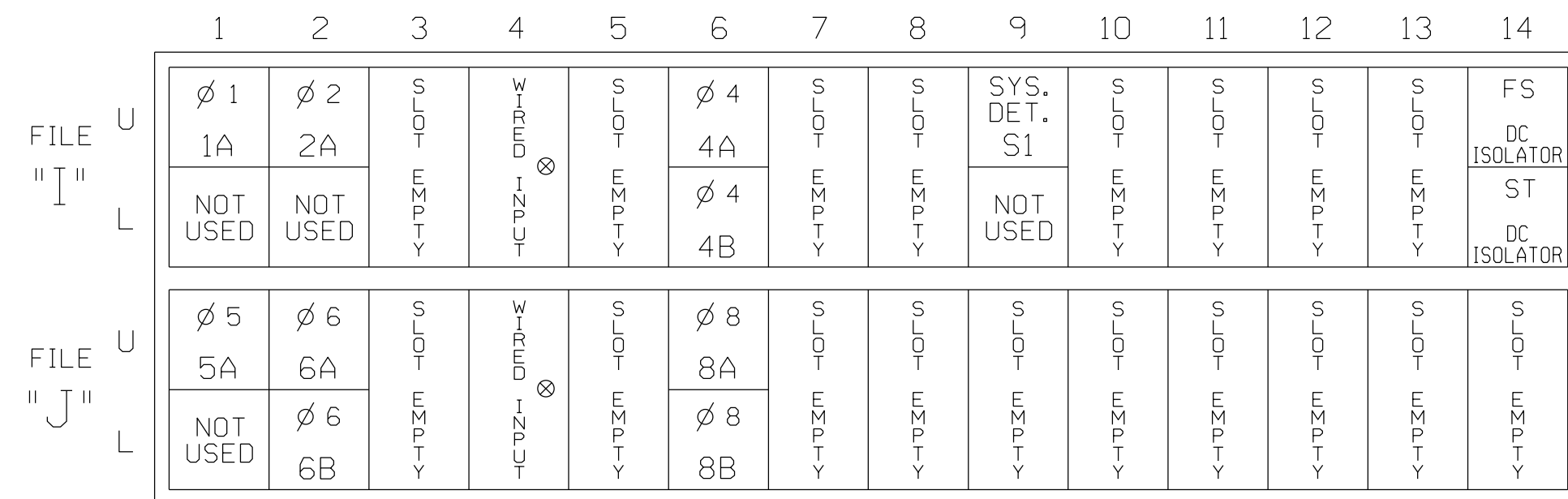

EX.: 1A, 2A, ETC. = LOOP NO.'S

FS = FLASH SENSE
 ST = STOP TIME

⊗ Wired Input - Do not populate slot with detector card

INPUT FILE CONNECTION & PROGRAMMING CHART

LOOP NO.	LOOP TERMINAL	INPUT FILE POS.	PIN NO.	DETECTOR NO.	NEMA PHASE	CALL	EXTEND TIME	DELAY TIME	ADDED INITIAL	DETECTOR TYPE
1A ¹	TB2-1,2	I1U	56	1 ★	1	YES		15		S
	-	J4U	48	26 ★	6	YES		3		S
2A	TB2-5,6	I2U	39	2	2	YES				S
4A	TB4-9,10	I6U	41	4	4	YES				S
4B	TB4-11,12	I6L	45	14	4	YES		15		S
* S1	TB6-9,10	I9U	60	11	SYS	NO				N
5A ²	TB3-1,2	J1U	55	5 ★	5	YES		15		S
	-	I4U	47	22 ★	2	YES		3		S
6A	TB3-5,6	J2U	40	6	6	YES				S
6B	TB3-7,8	J2L	44	16	6	YES				S
8A	TB5-9,10	J6U	42	8	8	YES				S
8B	TB5-11,12	J6L	46	18	8	YES		15		S

* System detector only. Remove any assigned vehicle phase.

¹Add jumper from I1-W to J4-W, on rear of input file.

²Add jumper from J1-W to I4-W, on rear of input file.

★ See vehicle detector setup programming detail for alternate phasing on sheet 2.

INPUT FILE POSITION LEGEND: J2L

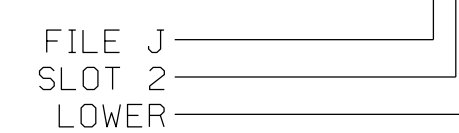

FYA SIGNAL WIRING DETAIL

(wire signal heads as shown)

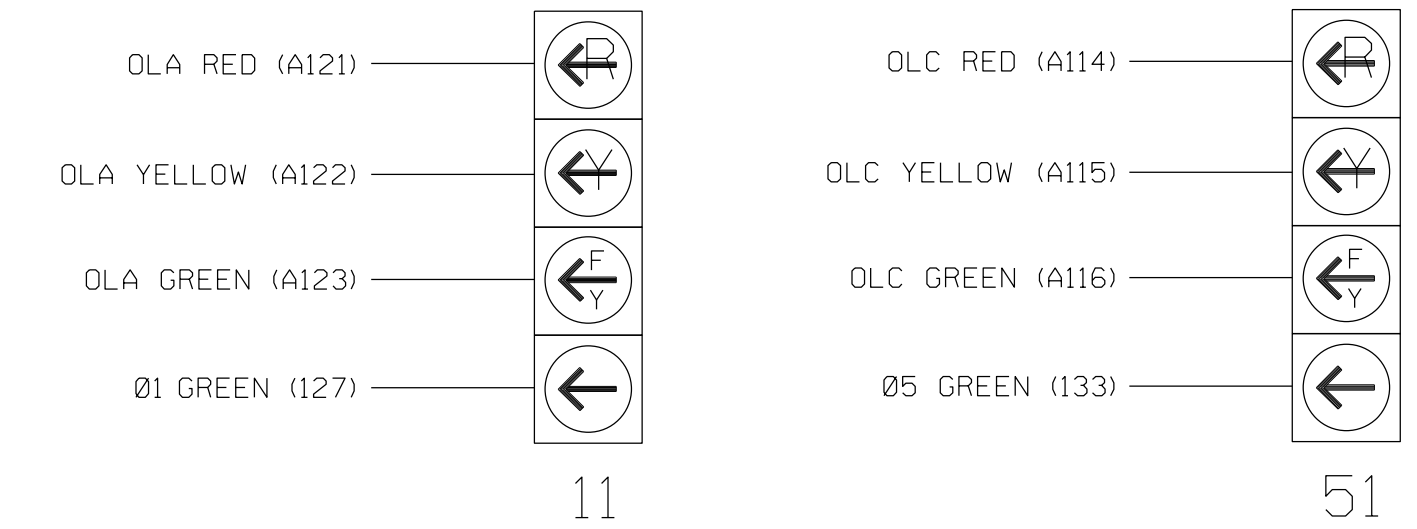

LOAD RESISTOR INSTALLATION DETAIL

(install resistors as shown)

VALUE (ohms)	WATTAGE
1.5K - 1.9K	25W (min)
2.0K - 3.0K	10W (min)

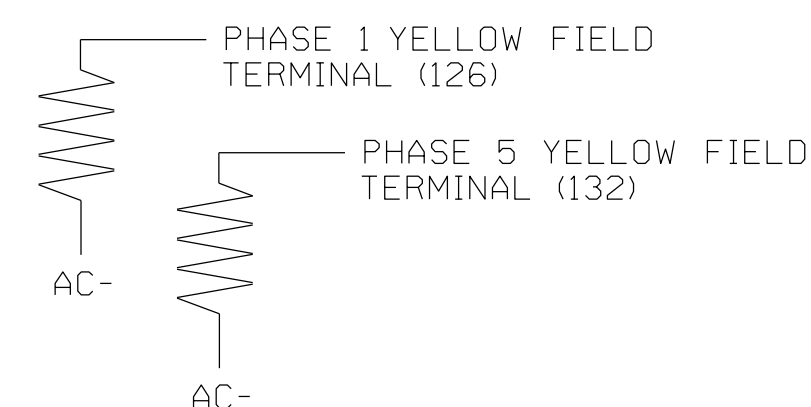

Signal Upgrade - Sheet 1 of 3

ELECTRICAL AND PROGRAMMING DETAILS FOR:



Edgewood Avenue
 at
 Shadowbrook Drive

Division 7 Alamance County Burlington

PLAN DATE: January 2018 REVIEWED BY: AJ Davis

PREPARED BY: DJ White REVIEWED BY: LM Moon

REVISIONS INIT. DATE

DOCUMENT NOT CONSIDERED FINAL UNLESS ALL SIGNATURES COMPLETED



DocuSigned by: Lisa M. Moon 6/13/2018

SIG. INVENTORY NO. B8023

ECONOLITE ASC/3-2070 VEHICLE DETECTOR SETUP PROGRAMMING DETAIL FOR ALTERNATE PHASING LOOPS 1A, 5A

(program controller as shown)

IMPORTANT!

Program detectors per the input file connection and programming chart shown on sheet 1 before proceeding.

- From Main Menu select **8. UTILITIES**
- From UTILITIES Submenu select **1. COPY/CLEAR**
- Copy from DETECTOR PLAN "1" to DETECTOR PLAN "2".

```

COPY / CLEAR UTILITY
FROM          TO
PHASE TIMING... > PHASE TIMING...
TIMING PLAN... > TIMING PLAN...
PH DET OPT PLAN. > PH DET OPT PLAN.
DETECTOR PLAN... 1 > DETECTOR PLAN... 2
TOGGLE TO SELECT A "FROM" AND A "TO"
THEN PRESS ENTER
  
```

- From Main Menu select **6. DETECTORS**
- From DETECTOR Submenu select **2. VEHICLE DETECTOR SETUP**
- Place cursor in VEH DET PLAN [] position and enter "2".

- Place cursor in VEH DECTECTOR [] position and enter "1".
 - Set delay time to "0".

```

VEH DETECTOR [ 1]  VEH DET PLAN [ 2]
TYPE: S-STANDARD
TS2 DETECTOR..... ECPI LOG..... NO
DET PH - 1 2 3 4 5 6 7 8 9 0 1 2 3 4 5 6
1 1 . . . . .
EXTEND TIME... 0.0 DELAY TIME... 0.0
USE ADDED INITIAL . CROSS SWITCH PH.. 0
LOCK IN..... NONE NTCIP VOL . OR OCC .
PMT QUEUE DELAY. NO
  
```

- Place cursor in VEH DECTECTOR [] position and enter "26".
 - Set assigned phase to "0".

```

VEH DETECTOR [26]  VEH DET PLAN [ 2]
TYPE: S-STANDARD
TS2 DETECTOR..... ECPI LOG..... NO
DET PH - 1 2 3 4 5 6 7 8 9 0 1 2 3 4 5 6
26 0 . . . . .
EXTEND TIME... 0.0 DELAY TIME... 0.0
USE ADDED INITIAL . CROSS SWITCH PH.. 0
LOCK IN..... NONE NTCIP VOL . OR OCC .
PMT QUEUE DELAY. NO
  
```

- Place cursor in VEH DECTECTOR [] position and enter "5".
 - Set delay time to "0".

```

VEH DETECTOR [ 5]  VEH DET PLAN [ 2]
TYPE: S-STANDARD
TS2 DETECTOR..... ECPI LOG..... NO
DET PH - 1 2 3 4 5 6 7 8 9 0 1 2 3 4 5 6
5 5 . . . . .
EXTEND TIME... 0.0 DELAY TIME... 0.0
USE ADDED INITIAL . CROSS SWITCH PH.. 0
LOCK IN..... NONE NTCIP VOL . OR OCC .
PMT QUEUE DELAY. NO
  
```

- Place cursor in VEH DECTECTOR [] position and enter "22".
 - Set assigned phase to "0".

```

VEH DETECTOR [22]  VEH DET PLAN [ 2]
TYPE: S-STANDARD
TS2 DETECTOR..... ECPI LOG..... NO
DET PH - 1 2 3 4 5 6 7 8 9 0 1 2 3 4 5 6
22 0 . . . . .
EXTEND TIME... 0.0 DELAY TIME... 0.0
USE ADDED INITIAL . CROSS SWITCH PH.. 0
LOCK IN..... NONE NTCIP VOL . OR OCC .
PMT QUEUE DELAY. NO
  
```

END PROGRAMMING

ECONOLITE ASC/3-2070 OVERLAP PROGRAMMING DETAIL

(program controller as shown)

- From Main Menu select **2. CONTROLLER**
- From CONTROLLER Submenu select **2. VEHICLE OVERLAPS**

OVERLAP A

Select TMG VEH OVLP [A] and 'PPLT FYA'

```

TMG VEH OVLP...[A] TYPE: ....PPLT FYA
PROTECTED LEFT TURN... PHASE 1
OPPOSING THROUGH..... PHASE 2

FLASHING ARROW OUTPUT....CH9 ISOLATE
DELAY START OF: FYA..0.0 CLEARANCE..0.0
ACTION PLAN SF BIT DISABLE..... 1
  
```

Toggle Twice

OVERLAP C

Select TMG VEH OVLP [C] and 'PPLT FYA'

```

TMG VEH OVLP...[C] TYPE: ....PPLT FYA
PROTECTED LEFT TURN... PHASE 5
OPPOSING THROUGH..... PHASE 6

FLASHING ARROW OUTPUT....CH11 ISOLATE
DELAY START OF: FYA..0.0 CLEARANCE..0.0
ACTION PLAN SF BIT DISABLE..... 5
  
```

END PROGRAMMING

THIS ELECTRICAL DETAIL IS FOR
 THE SIGNAL DESIGN: B8023
 DESIGNED: JANUARY 2018
 SEALED: 06-13-2018
 REVISED: N/A

Signal Upgrade - Sheet 2 of 3

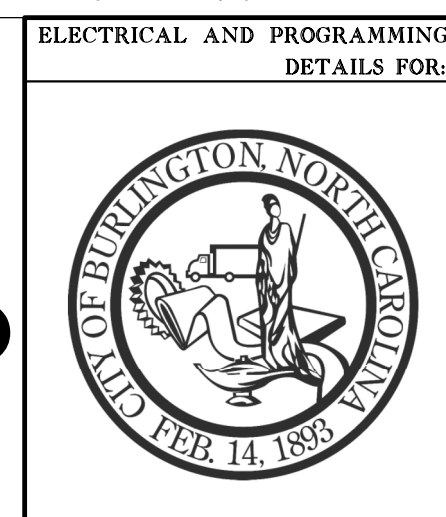

Edgewood Avenue at Shadowbrook Drive	
Division 7 Alamance County	Burlington
PLAN DATE: January 2018	REVIEWED BY: AJ Davis
PREPARED BY: DJ White	REVIEWED BY: LM Moon
REVISIONS	INIT. DATE

DOCUMENT NOT CONSIDERED FINAL UNLESS ALL SIGNATURES COMPLETED

SEAL
 NORTH CAROLINA
 PROFESSIONAL
 ENGINEER
 LISA M. MOON
 022516

DocuSigned by:
 Lisa M. Moon
 6/13/2018
 DATE

SIG. INVENTORY NO. B8023



13-JUN-2018 18:04 R:\66015\Proj\esignals\design\wlr\img\B8023a.dgn KANDERSON AT CHA-KANDERSON

ALTERNATE PHASING ACTIVATION DETAIL

TO RUN ALT. PHASING DURING FREE RUN - PROGRAM CHANGES (SHOWN BELOW) IN A TIME BASED ACTION PLAN. SCHEDULE A DAY PLAN THAT INCLUDES THE ACTION PLAN PROGRAMMED TO SELECT VEH DET PLAN 2 AND ENABLE SF BITS 1 AND 5.

TO RUN ALT. PHASING DURING COORDINATION - SELECT THE TIME BASED ACTIN PLAN THAT IS PROGRAMMED TO SELECT VEH DET PLAN 2 AND ENABLE SF BITS 1 AND 5.

PHASING	VEH DET PLAN	SF BITS ENABLED
ACTIONS REQUIRED TO RUN <u>DEFAULT</u> PHASING	1	NONE
ACTIONS REQUIRED TO RUN <u>ALTERNATE</u> PHASING	2	1, 5

IMPORTANT: IF ALT. PHASING IS USED DURING FREE RUN AND COORDINATION, DO NOT OPERATE TIME OF DAY EVENTS CONCURRENTLY WITH COORDINATION PLAN EVENTS IN THE EVENT SCHEDULER. (EX. FREE RUN EVENT SHOULD END BEFORE COORDINATION PLAN EVENT STARTS AND VICE-VERSA).

ALTERNATE PHASING CHANGE SUMMARY

THE FOLLOWING IS A SUMMARY OF WHAT TAKES PLACE WHEN SF BITS 1 AND 5 AND VEH DET PLAN 2 ACTIVATE TO CALL THE "ALTERNATE PHASING":

SF BITS 1,5: Modifies overlap parent phases for heads 11 and 51 to run protected turns only

VEH DET PLAN 2: Disables phase 6 call on loop 1A and reduces delay time for phase 1 call on loop 1A to 0 seconds.

Disables phase 2 call on loop 5A and reduces delay time for phase 5 call on loop 5A to 0 seconds.

ECONOLITE ASC/3-2070 ACTION PLAN PROGRAMMING DETAIL

- From Main Menu select **5. TIME BASE**
- From TIME BASE Submenu select **2. ACTION PLAN**

```



ACTION PLAN...[ 1]
PATTERN.....AUTO  SYS OVERRIDE.... NO
TIMING PLAN..... 0  SEQUENCE..... 0
VEH DETECTOR PLAN.. 2  DET LOG.....NONE
FLASH..... --  RED REST..... NO
VEH DET DIAG PLN... 0  PED DET DIAG PLN..0
DIMMING ENABLE.. NO  PRIORITY RETURN. NO
PED PR RETURN.. NO  QUEUE DELAY..... NO
PMT COND DELAY NO
  PHASE  1  2  3  4  5  6  7  8  9  0  1  2  3  4  5  6
PED RCL  .  .  .  .  .  .  .  .  .  .  .  .  .  .  .  .
WALK 2   .  .  .  .  .  .  .  .  .  .  .  .  .  .  .  .
VEX 2    .  .  .  .  .  .  .  .  .  .  .  .  .  .  .  .
VEH RCL  .  .  .  .  .  .  .  .  .  .  .  .  .  .  .  .
MAX RCL  .  .  .  .  .  .  .  .  .  .  .  .  .  .  .  .
MAX 2    .  .  .  .  .  .  .  .  .  .  .  .  .  .  .  .
  PHASE  1  2  3  4  5  6  7  8  9  0  1  2  3  4  5  6
MAX 3    .  .  .  .  .  .  .  .  .  .  .  .  .  .  .  .
CS INH   .  .  .  .  .  .  .  .  .  .  .  .  .  .  .  .
OMIT     .  .  .  .  .  .  .  .  .  .  .  .  .  .  .  .
SPC FCT  X  .  .  .  X  .  .  .  (1-8)
AUX FCT  .  .  .  (1-3)
          1  2  3  4  5  6  7  8  9  0  1  2  3  4  5
LP 1-15  .  .  .  .  .  .  .  .  .  .  .  .  .  .  .  .
LP 16-30 .  .  .  .  .  .  .  .  .  .  .  .  .  .  .  .
LP 31-45 .  .  .  .  .  .  .  .  .  .  .  .  .  .  .  .
LP 46-60 .  .  .  .  .  .  .  .  .  .  .  .  .  .  .  .
LP 61-75 .  .  .  .  .  .  .  .  .  .  .  .  .  .  .  .
LP 76-90 .  .  .  .  .  .  .  .  .  .  .  .  .  .  .  .
LP 91-100 .  .  .  .  .  .  .  .  .  .  .  .  .  .  .  .

```

THIS ELECTRICAL DETAIL IS FOR THE SIGNAL DESIGN: B8023
DESIGNED: JANUARY 2018
SEALED: 06-13-2018
REVISED: N/A

13-JUN-2018 18:04 R:\66015\Prof\esignals\design\wiring\B8023a.dgn KANDERSON AT CHA-KANDERSON

Signal Upgrade - Sheet 3 of 3

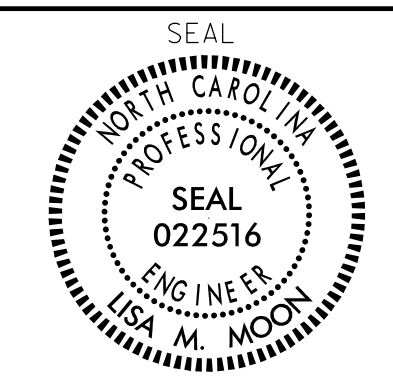
 <p>DRMP, Inc. 8000 Regency Parkway, Suite 175 Cary, NC 27519 NC License No. C-2213 (919) 650-1038</p>		Edgewood Avenue at Shadowbrook Drive		
		Division 7 Alamance County Burlington	PLAN DATE: January 2018 REVIEWED BY: AJ Davis	
PREPARED BY: DJ White REVIEWED BY: LM Moon		REVISIONS	INIT. DATE	DocuSigned by: Lisa M. Moon 6/13/2018
ELECTRICAL AND PROGRAMMING DETAILS FOR:				SIG. INVENTORY NO. B8023

DOCUMENT NOT CONSIDERED FINAL UNLESS ALL SIGNATURES COMPLETED

ECONOLITE ASC/3-2070 VEHICLE DETECTOR SETUP PROGRAMMING DETAIL FOR ALTERNATE PHASING LOOP 5A

(program controller as shown)

IMPORTANT!

Program detectors per the input file connection and programming chart shown on sheet 1 before proceeding.

- From Main Menu select **8. UTILITIES**
- From UTILITIES Submenu select **1. COPY/CLEAR**
- Copy from DETECTOR PLAN "1" to DETECTOR PLAN "2".

```

COPY / CLEAR UTILITY
      FROM          TO
PHASE TIMING.... > PHASE TIMING....
TIMING PLAN..... > TIMING PLAN.....
PH DET OPT PLAN. > PH DET OPT PLAN.
DETECTOR PLAN... 1 > DETECTOR PLAN... 2
      TOGGLE TO SELECT A "FROM" AND A "TO"
      THEN PRESS ENTER
  
```

- From Main Menu select **6. DETECTORS**
- From DETECTOR Submenu select **2. VEHICLE DETECTOR SETUP**
- Place cursor in VEH DET PLAN [] position and enter "2".
 - Place cursor in VEH DETECTOR [] position and enter "5".
 - Set delay time to "0".

```

VEH DETECTOR [ "5" ] VEH DET PLAN [ "2" ]
TYPE: S-STANDARD
TS2 DETECTOR..... ECPI LOG..... NO
DET PH - 1 2 3 4 5 6 7 8 9 0 1 2 3 4 5 6
      5 5
EXTEND TIME... 0.0 DELAY TIME... "0.0"
USE ADDED INITIAL . CROSS SWITCH PH.. 0
LOCK IN..... NONE NTCIP VOL . OR OCC .
PMT QUEUE DELAY. NO
  
```

← NOTICE VEH DET PLAN 2

← ENSURE DELAY IS SET TO "0"

- Place cursor in VEH DETECTOR [] position and enter "22".
- Set assigned phase to "0".

```

VEH DETECTOR [ "22" ] VEH DET PLAN [ "2" ]
TYPE: G-GREEN EXTENSION/DELAY
TS2 DETECTOR..... ECPI LOG..... NO
DET PH - 1 2 3 4 5 6 7 8 9 0 1 2 3 4 5 6
      22 0
EXTEND TIME... 0.0 DELAY TIME... "0.0"
USE ADDED INITIAL . CROSS SWITCH PH.. 0
LOCK IN..... NONE NTCIP VOL . OR OCC .
PMT QUEUE DELAY. NO
  
```

← NOTICE VEH DET PLAN 2

→ ENSURE PHASE IS SET TO "0"

END PROGRAMMING

ECONOLITE ASC/3-2070 OVERLAP PROGRAMMING DETAIL (program controller as shown)

- From Main Menu select **2. CONTROLLER**
- From CONTROLLER Submenu select **2. VEHICLE OVERLAPS**

OVERLAP A

Select TMG VEH OVLP [A] and 'OTHER/ECONOLITE'

```

TMG VEH OVLP... [A] TYPE: OTHER/ECONOLITE
PHASES 1 2 3 4 5 6 7 8 9 0 1 2 3 4 5 6
INCLUDED . X . . . . .
PROTECT . . . . .
PED PRTC . . . . .
NOT OVLP . . . . .
FLSH GRN . 1 . . . . .
LAG X PH . . . . .
LAG 2 PH . . . . .

LAG GRN 0.0 YEL 0.0 RED 0.0 ADV GRN 0.0
  
```

Toggle Twice

OVERLAP C

Select TMG VEH OVLP [C] and 'PPLT FYA'

```

TMG VEH OVLP... [C] TYPE: PPLT FYA
PROTECTED LEFT TURN.... PHASE 5
OPPOSING THROUGH..... PHASE 6

FLASHING ARROW OUTPUT....CH11 ISOLATE
DELAY START OF: FYA..0.0 CLEARANCE..0.0
ACTION PLAN SF BIT DISABLE..... 5
  
```

← NOTICE ACTION PLAN SF BIT "5"

END PROGRAMMING

THIS ELECTRICAL DETAIL IS FOR THE SIGNAL DESIGN: B8024
 DESIGNED: NOVEMBER 2017
 SEALED: 06-13-2018
 REVISED: N/A

13-UNA-2018-18-02 R:\66015\1\proj\esign\gms\design\w\ir\img\B8024e.dgn C:\lowton AT CAR-RLANTON-W7

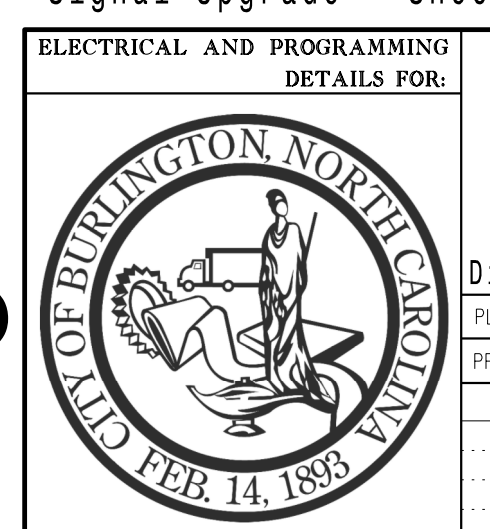

Signal Upgrade - Sheet 2 of 3

Briarcliff Road/ Shadowbrook Drive at Saddle Club Road	
Division 7	Alamance County Burlington
PLAN DATE: November 2017	REVIEWED BY: AJ Davis
PREPARED BY: J Le	REVIEWED BY: LM Moon
REVISIONS	INIT. DATE

DOCUMENT NOT CONSIDERED FINAL UNLESS ALL SIGNATURES COMPLETED

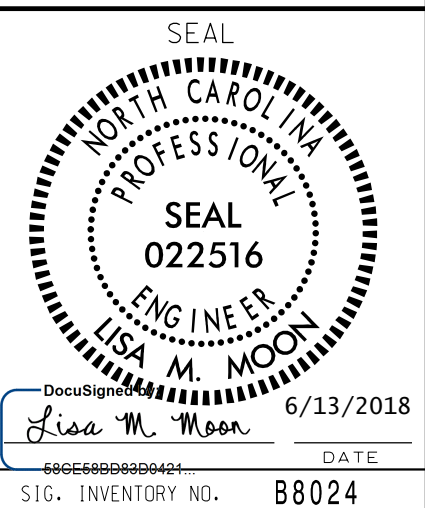

DocuSign 6/13/2018
Lisa M. Moon
DATE
SIG. INVENTORY NO. B8024

ALTERNATE PHASING ACTIVATION DETAIL

TO RUN ALT. PHASING DURING FREE RUN - PROGRAM CHANGES (SHOWN BELOW) IN A TIME BASED ACTION PLAN. SCHEDULE A DAY PLAN THAT INCLUDES THE ACTION PLAN PROGRAMMED TO SELECT VEH DET PLAN 2 AND ENABLE SF BIT 5

TO RUN ALT. PHASING DURING COORDINATION - SELECT THE TIME BASED ACTION PLAN THAT IS PROGRAMMED TO SELECT VEH DET PLAN 2 AND ENABLE SF BIT 5

PHASING	VEH DET PLAN	SF BITS ENABLED
ACTIONS REQUIRED TO RUN <u>DEFAULT PHASING</u>	1	NONE
ACTIONS REQUIRED TO RUN <u>ALTERNATE PHASING</u>	2	5

IMPORTANT: IF ALT. PHASING IS USED DURING FREE RUN AND COORDINATION, DO NOT OPERATE TIME OF DAY EVENTS CONCURRENTLY WITH COORDINATION PLAN EVENTS IN THE EVENT SCHEDULER. (EX. FREE RUN EVENT SHOULD END BEFORE COORDINATION PLAN EVENT STARTS AND VICE-VERSA).

ALTERNATE PHASING CHANGE SUMMARY

THE FOLLOWING IS A SUMMARY OF WHAT TAKES PLACE WHEN SF BIT 5 AND VEH DET PLAN 2 ACTIVATE TO CALL THE "ALTERNATE PHASING":

SF BIT 5: Modifies overlap parent phases for head 51 to run protected turns only.

VEH DET PLAN 2: Disables phase 2 call on loop 5A and reduces delay time for phase 5 call on loop 5A to 0 seconds.

ECONOLITE ASC/3-2070 ACTION PLAN PROGRAMMING DETAIL

- From Main Menu select **5. TIME BASE**
- From TIME BASE Submenu select **2. ACTION PLAN**

```

ACTION PLAN...[ 1]
PATTERN.....AUTO  SYS OVERRIDE.... NO
TIMING PLAN..... 0  SEQUENCE..... 0
VEH DETECTOR PLAN.. 2  DET LOG.....NONE
FLASH..... --  RED REST..... NO
VEH DET DIAG PLN... 0  PED DET DIAG PLN..0
DIMMING ENABLE.. NO  PRIORITY RETURN. NO
PED PR RETURN.. NO  QUEUE DELAY..... NO
PMT COND DELAY  NO
  PHASE  1  2  3  4  5  6  7  8  9  0  1  2  3  4  5  6
PED RCL  .  .  .  .  .  .  .  .  .  .  .  .  .  .  .  .
WALK 2   .  .  .  .  .  .  .  .  .  .  .  .  .  .  .  .
VEX 2    .  .  .  .  .  .  .  .  .  .  .  .  .  .  .  .
VEH RCL  .  .  .  .  .  .  .  .  .  .  .  .  .  .  .  .
MAX RCL  .  .  .  .  .  .  .  .  .  .  .  .  .  .  .  .
MAX 2    .  .  .  .  .  .  .  .  .  .  .  .  .  .  .  .
  PHASE  1  2  3  4  5  6  7  8  9  0  1  2  3  4  5  6
MAX 3    .  .  .  .  .  .  .  .  .  .  .  .  .  .  .  .
CS INH   .  .  .  .  .  .  .  .  .  .  .  .  .  .  .  .
OMIT     .  .  .  .  .  .  .  .  .  .  .  .  .  .  .  .
SPC FCT  .  .  .  .  X  .  .  .  .  (1-8)
AUX FCT  .  .  .  (1-3)
          1  2  3  4  5  6  7  8  9  0  1  2  3  4  5
LP 1-15  .  .  .  .  .  .  .  .  .  .  .  .  .  .  .  .
LP 16-30 .  .  .  .  .  .  .  .  .  .  .  .  .  .  .  .
LP 31-45 .  .  .  .  .  .  .  .  .  .  .  .  .  .  .  .
LP 46-60 .  .  .  .  .  .  .  .  .  .  .  .  .  .  .  .
LP 61-75 .  .  .  .  .  .  .  .  .  .  .  .  .  .  .  .
LP 76-90 .  .  .  .  .  .  .  .  .  .  .  .  .  .  .  .
LP 91-100 .  .  .  .  .  .  .  .  .  .  .  .  .  .  .  .
    
```

THIS ELECTRICAL DETAIL IS FOR
 THE SIGNAL DESIGN: B8024
 DESIGNED: NOVEMBER 2017
 SEALED: 06-13-2018
 REVISED: N/A

Signal Upgrade - Sheet 3 of 3

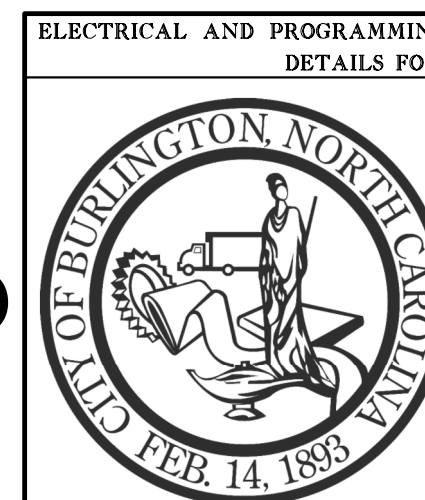
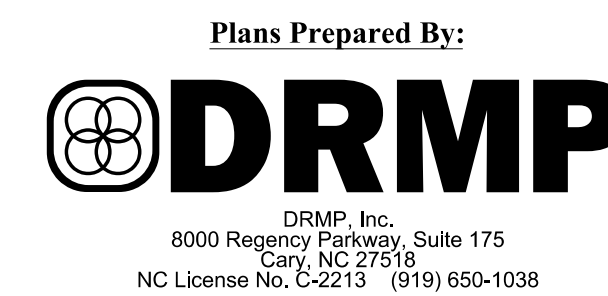

Briarcliff Road/ Shadowbrook Drive at Saddle Club Road	
Division 7	Alamance County
PLAN DATE: November 2017	REVIEWED BY: AJ Davis
PREPARED BY: J Le	REVIEWED BY: LM Moon
REVISIONS	INIT. DATE

DOCUMENT NOT CONSIDERED FINAL UNLESS ALL SIGNATURES COMPLETED

SEAL
 NORTH CAROLINA
 PROFESSIONAL
 SEAL
 022516
 ENGINEER
 LISA M. MOON
 DATE: 6/13/2018
 SIG. INVENTORY NO. B8024

EDI MODEL 2018ECLip-NC CONFLICT MONITOR PROGRAMMING DETAIL

(remove jumpers and set switches as shown)

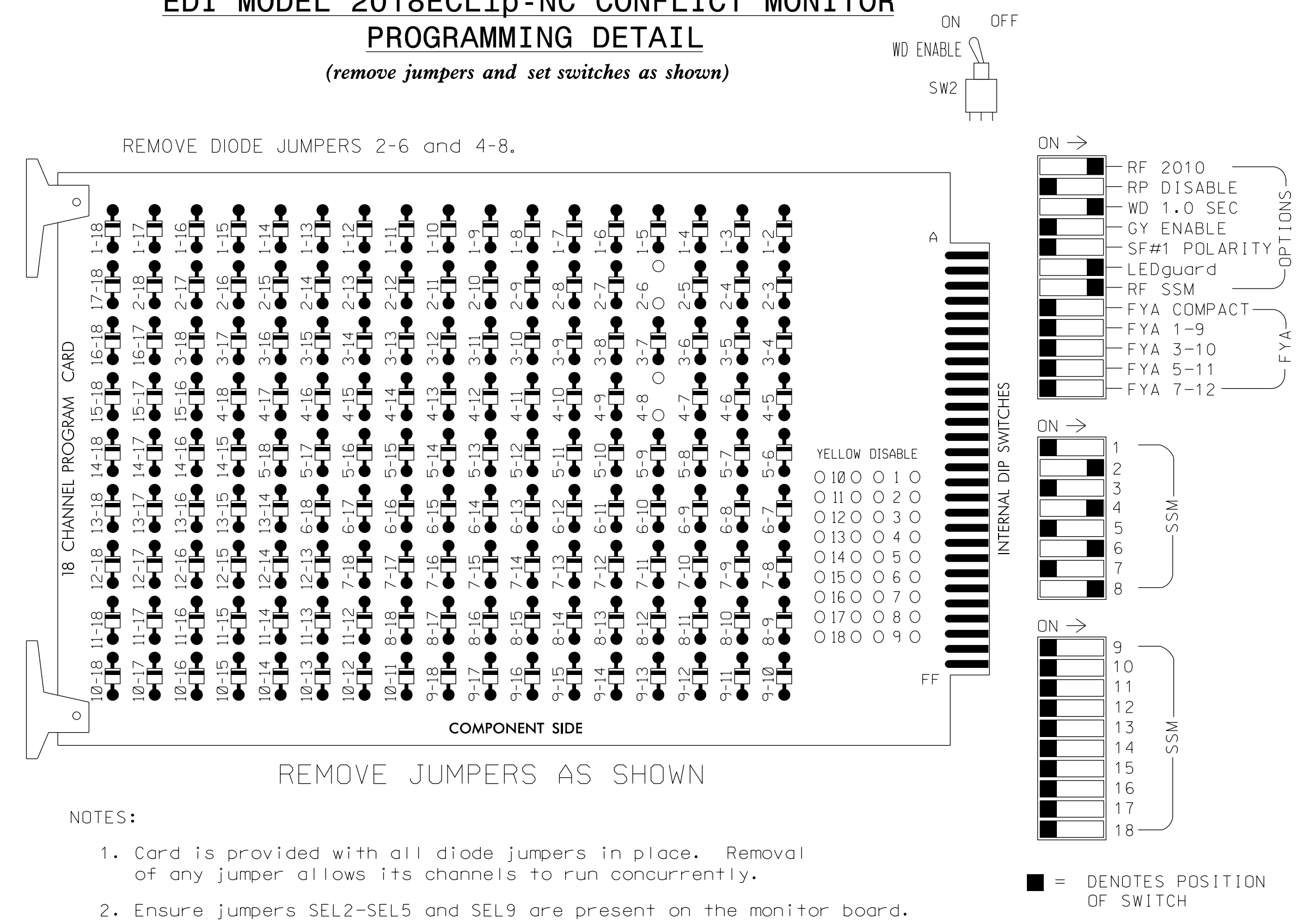

NOTES:

- Card is provided with all diode jumpers in place. Removal of any jumper allows its channels to run concurrently.
- Ensure jumpers SEL2-SEL5 and SEL9 are present on the monitor board.
- Ensure that Red Enable is active at all times during normal operation.
- Integrate monitor with Ethernet network in cabinet.

NOTES

- To prevent "flash-conflict" problems, insert red flash program blocks for all unused vehicle load switches in the output file. The installer shall verify that signal heads flash in accordance with the Signal Plans.
- Program phases 4 and 8 for Dual Entry.
- Program controller to start up in phase 2 Green and 6 Green.
- The cabinet and controller are part of the Burlington-Graham Signal System.

SIGNAL HEAD HOOK-UP CHART

LOAD SWITCH NO.	S1	S2	S3	S4	S5	S6	S7	S8	S9	S10	S11	S12
CMU CHANNEL NO.	1	2	13	3	4	14	5	6	15	7	8	16
PHASE	1	2	2 PED	3	4	4 PED	5	6	6 PED	7	8	8 PED
SIGNAL HEAD NO.	NU	21,22	NU	NU	41,42	NU	NU	61,62	NU	NU	81,82	NU
RED		128			101			134			107	
YELLOW		129			102			135			108	
GREEN		130			103			136			109	
RED ARROW												
YELLOW ARROW												
GREEN ARROW												

NU = Not Used

EQUIPMENT INFORMATION

CONTROLLER.....2070LX
 CABINET.....336
 SOFTWARE.....ECONOLITE ASC/3-2070
 CABINET MOUNT.....POLE
 OUTPUT FILE POSITIONS...12
 LOAD SWITCHES USED.....S2,S5,S8,S11
 PHASES USED.....2,4,6,8
 OVERLAPS.....NONE

INPUT FILE POSITION LAYOUT

(front view)

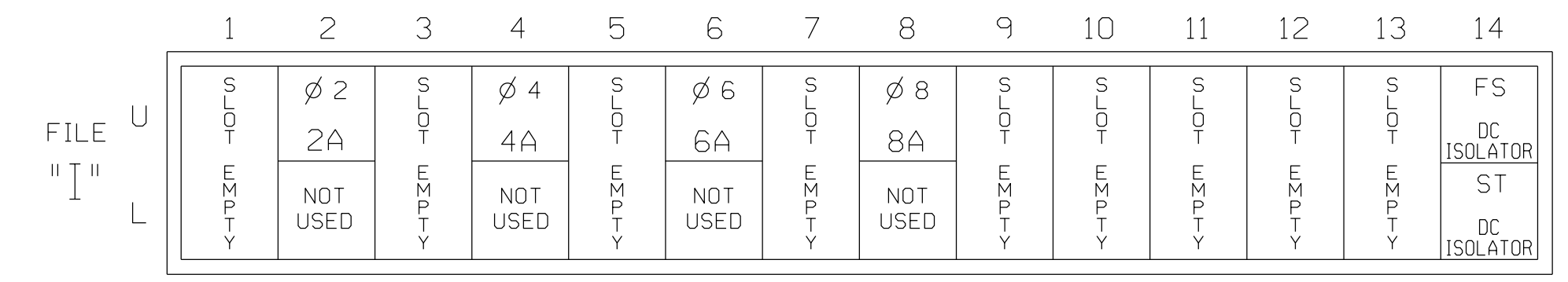

EX.: 1A, 2A, ETC. = LOOP NO.'S

FS = FLASH SENSE
 ST = STOP TIME

INPUT FILE CONNECTION & PROGRAMMING CHART

LOOP NO.	LOOP TERMINAL	INPUT FILE POS.	PIN NO.	DETECTOR NO.	NEMA PHASE	CALL	EXTEND TIME	DELAY TIME	ADDED INITIAL	DETECTOR TYPE
2A	TB21-3,4	12U	39	2	2	YES				S
4A	TB21-7,8	14U	41	4	4	YES		5		S
6A	TB21-11,12	16U	40	6	6	YES				S
8A	TB22-1,2	18U	42	8	8	YES		5		S

INPUT FILE POSITION LEGEND: J2L

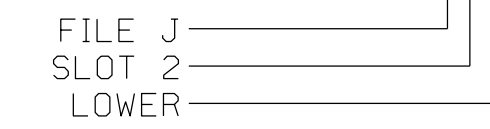

THIS ELECTRICAL DETAIL IS FOR THE SIGNAL DESIGN: B8025
 DESIGNED: SEPT-2017
 SEALED:
 REVISED: N/A

13-UNA-2018-18-03
 R:\66015\17\off\caks\gnols\des\gnw\ir\mg*B8025a.dgn
 C:\lowton AT CAR-RLANTON-W7



Electrical Detail

ELECTRICAL AND PROGRAMMING DETAILS FOR:

N. Main Street at Holt Street

Division 7 Alamance County Burlington

PLAN DATE: Sept 2017 REVIEWED BY: AJ Davis

PREPARED BY: DJ White REVIEWED BY: LM Moon

REVISIONS	INIT.	DATE

DOCUMENT NOT CONSIDERED FINAL UNLESS ALL SIGNATURES COMPLETED

SEAL

DocuSigned by:
Lisa M. Moon 6/13/2018
 DATE

SIG. INVENTORY NO. B8025

DEFAULT PHASING DIAGRAM

ALTERNATE PHASING DIAGRAM

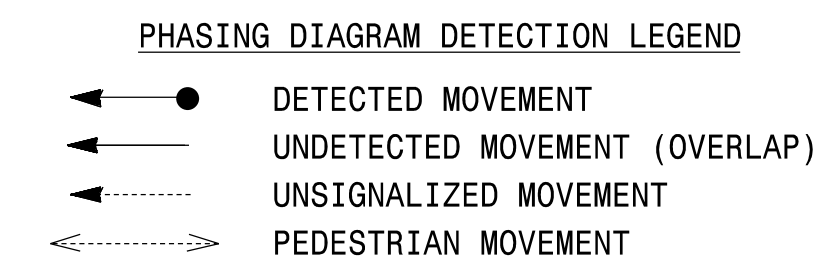
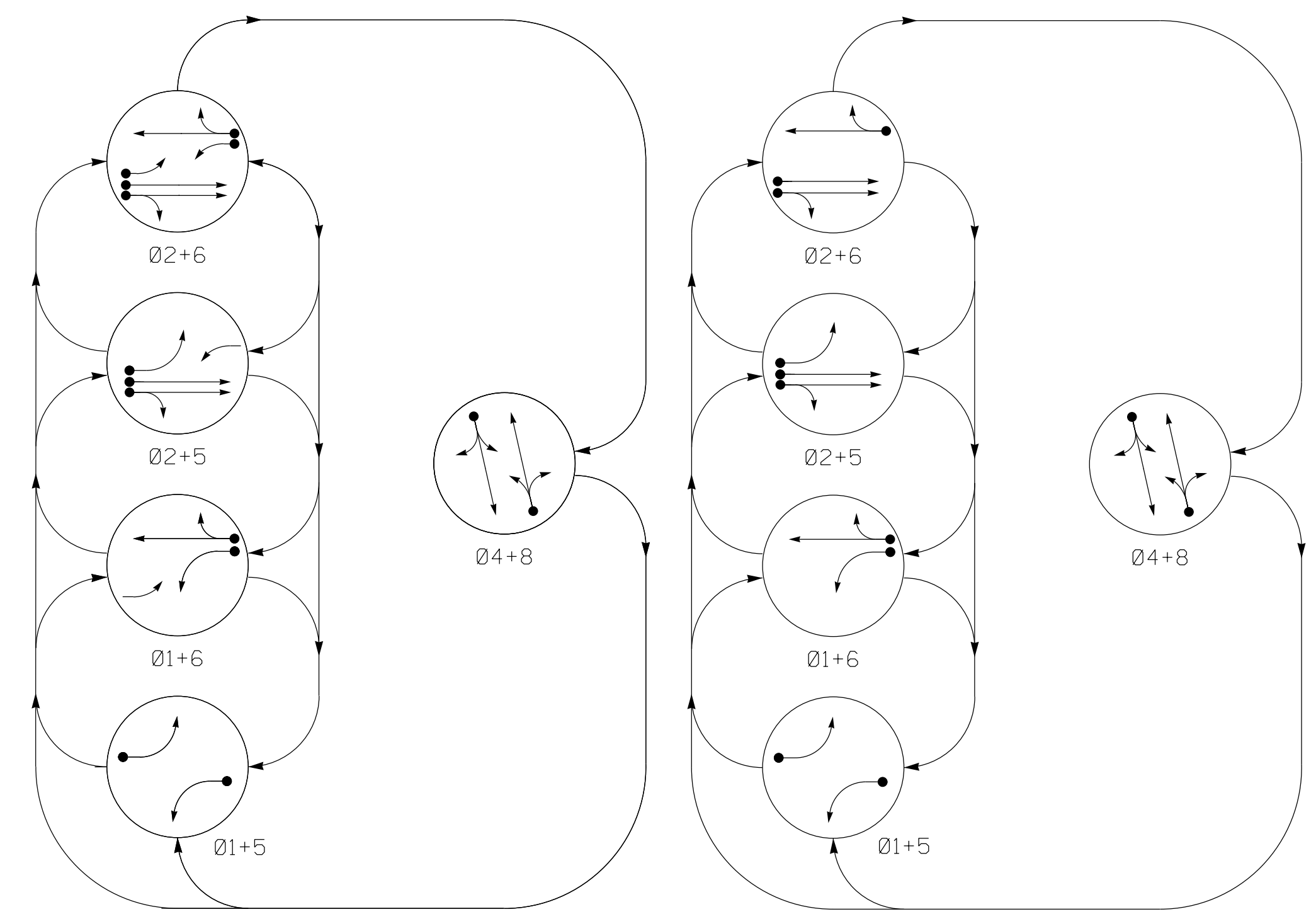

SIGNAL FACE I.D.

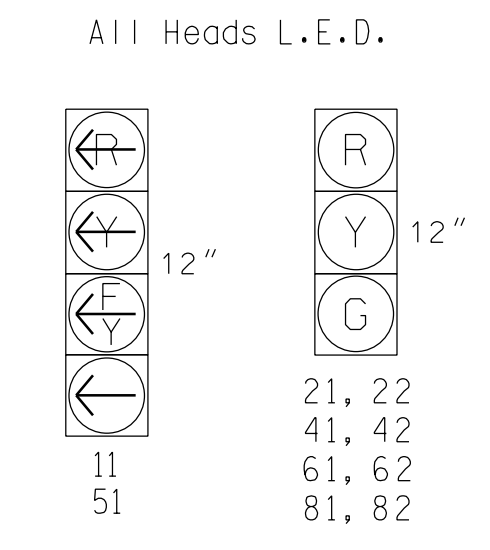

DEFAULT PHASING TABLE OF OPERATION

SIGNAL FACE	PHASE					
	01+5	01+6	02+5	02+6	04+8	FLUSH
11	←	←	←	←	←	←
21, 22	R	R	G	G	R	Y
41, 42	R	R	R	R	R	R
51	←	←	←	←	←	←
61, 62	R	G	R	G	R	Y
81, 82	R	R	R	R	G	R

ALTERNATE PHASING TABLE OF OPERATION

SIGNAL FACE	PHASE					
	01+5	01+6	02+5	02+6	04+8	FLUSH
11	←	←	←	←	←	←
21, 22	R	R	G	G	R	Y
41, 42	R	R	R	R	R	R
51	←	←	←	←	←	←
61, 62	R	G	R	G	R	Y
81, 82	R	R	R	R	G	R

ASC/3 DETECTOR INSTALLATION CHART

LOOP	SIZE (FT)	DISTANCE FROM STOPBAR (FT)	TURNS	PROGRAMMING								
				NEW LOOP	PHASE	CALLING	EXTEND TIME	DELAY TIME	USE ADDED INITIAL	TYPE	SYSTEM LOOP	NEW CARD
1A	6X40	0	2-4-2	-	1	Yes	-	*15	-	S	-	X
2A,2B	6X6	70	EXIST	-	2	Yes	-	-	-	S	-	X
4A	6X40	+2	2-4-2	-	4	Yes	-	5	-	S	-	X
5A	6X40	0	2-4-2	-	5	Yes	-	*15	-	S	-	X
6A	6X6	70	EXIST	-	6	Yes	-	-	-	S	-	X
8A	6X40	0	2-4-2	-	8	Yes	-	5	-	S	-	X

* Disable delay during alternate phasing operation.
 ** Disable phase 6 call during alternate phasing operation.

5 Phase Fully Actuated (Burlington-Graham Signal System)

NOTES

- Refer to "Roadway Standard Drawings NCDOT" dated January 2018 and "Standard Specifications for Roads and Structures" dated January 2018.
- Do not program signal for late night flashing operation unless otherwise directed by the Engineer.
- Phase 1 and/or phase 5 may be lagged.
- Set all detector units to presence mode.
- Locate new cabinet so as not to obstruct vehicles turning right on red.
- Pavement markings are existing.
- The City Traffic Engineer will determine the hours of use for each phasing plan.
- Maximum times shown in timing chart are for free-run operation only. Coordinated signal system timing values supersede these values.

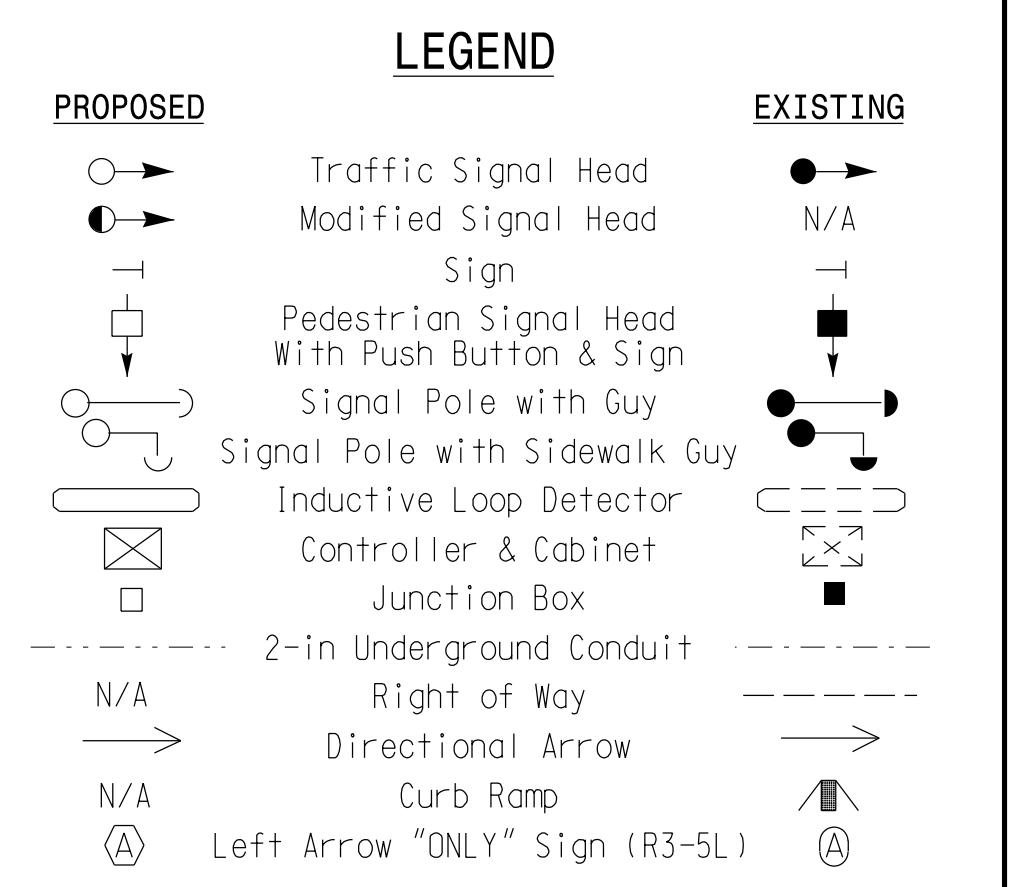
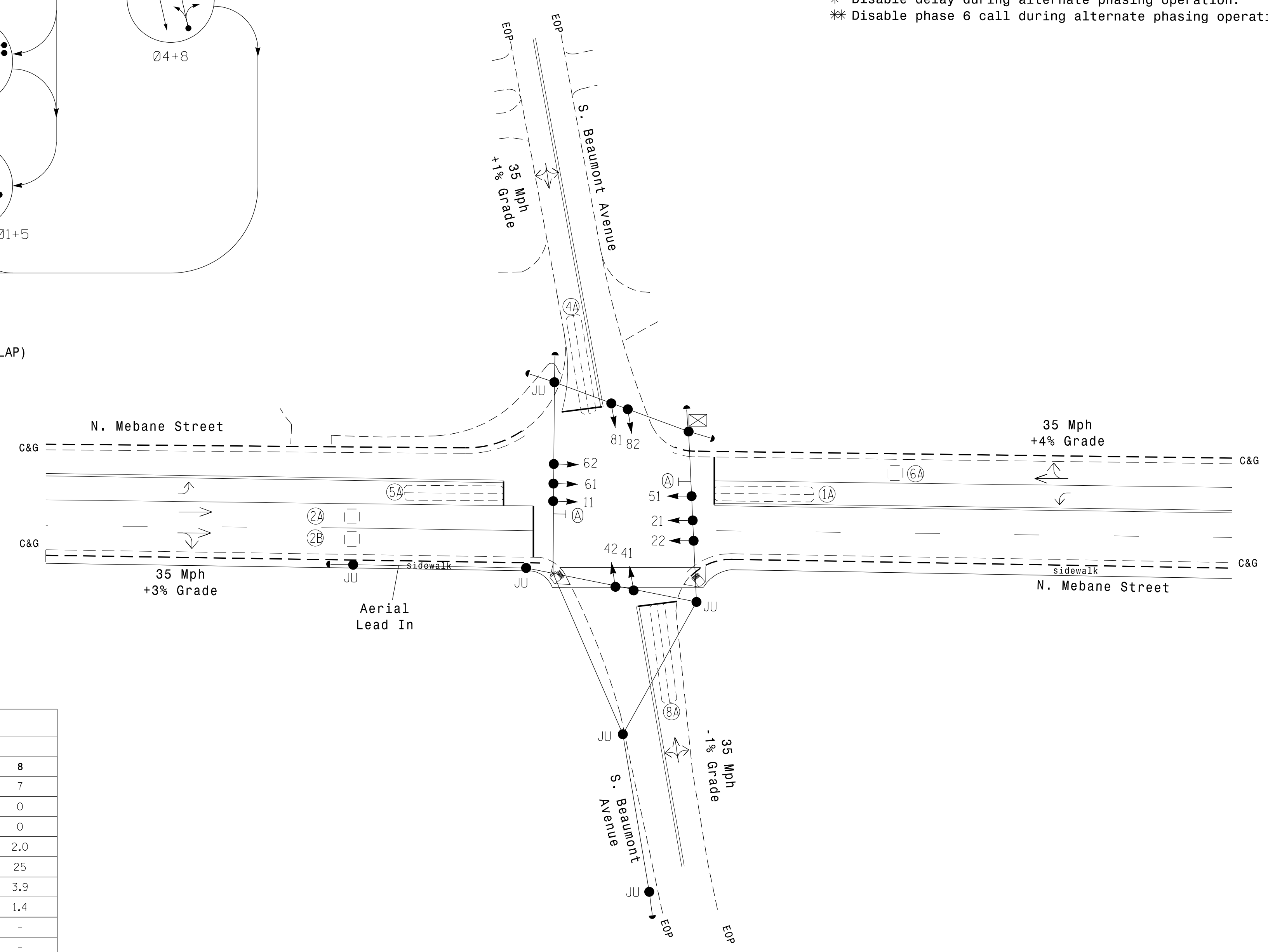

ASC/3 TIMING CHART

FEATURE	PHASE							
	1	2	4	5	6	8		
Min Green *	7	10	7	7	10	7		
Walk *	0	0	0	0	0	0		
Ped Clear	0	0	0	0	0	0		
Veh. Extension *	2.0	3.0	2.0	2.0	3.0	2.0		
Max I *	15	45	25	15	45	25		
Yellow	3.0	3.7	3.8	3.0	3.7	3.9		
Red Clear	1.8	1.2	1.3	1.8	1.2	1.4		
Actuations B4 Add *	-	-	-	-	-	-		
Seconds / Actuation *	-	-	-	-	-	-		
Max Initial *	-	-	-	-	-	-		
Time Before Reduction *	-	-	-	-	-	-		
Time To Reduce *	-	-	-	-	-	-		
Minimum Gap	-	-	-	-	-	-		
Locking Detector	-	X	-	-	X	-		
Recall Position	-	VEH. RECALL	-	-	VEH. RECALL	-		
Dual Entry	-	-	X	-	-	X		
Simultaneous Gap	X	X	X	X	X	X		

* These values may be field adjusted. Do not adjust Min Green and Extension times for phases 2 and 6 lower than what is shown. Min Green for all other phases should not be lower than 4 seconds.

Signal Upgrade

DOCUMENT NOT CONSIDERED FINAL UNLESS ALL SIGNATURES COMPLETED

Seal of the City of Burlington, North Carolina

N. Mebane Street at S. Beaumont Avenue

Division 7 Alamance County Burlington

PLAN DATE: February 2018 REVIEWED BY: AM Encarnacion

PREPARED BY: NA Ptak REVIEWED BY: PL Alexander

Seal of Pamela L. Alexander, Professional Engineer, State of North Carolina

REVISIONS

NO.	DATE	DESCRIPTION

DATE: 6/7/2018

Signature: Pamela Alexander

DATE: _____

SIG. INVENTORY NO. B-8026

07-JUN-2018 11:15 D:\Projects\Burlington\Traffic\Task\00056469 U-6015 B-G S19 Signal\Des\gpm8-8026.dgn ALEX3361 AT LUS3361

ECONOLITE ASC/3-2070 VEHICLE DETECTOR SETUP PROGRAMMING DETAIL FOR ALTERNATE PHASING LOOPS 1A, 5A

(program controller as shown)

IMPORTANT!

Program detectors per the input file connection and programming chart shown on sheet 1 before proceeding.

- From Main Menu select **8. UTILITIES**
- From UTILITIES Submenu select **1. COPY/CLEAR**
- Copy from DETECTOR PLAN "1" to DETECTOR PLAN "2".

```

COPY / CLEAR UTILITY
FROM          TO
PHASE TIMING... > PHASE TIMING...
TIMING PLAN... > TIMING PLAN...
PH DET OPT PLAN. > PH DET OPT PLAN.
DETECTOR PLAN... 1 > DETECTOR PLAN... 2
TOGGLE TO SELECT A "FROM" AND A "TO"
THEN PRESS ENTER
    
```

- From Main Menu select **6. DETECTORS**
- From DETECTOR Submenu select **2. VEHICLE DETECTOR SETUP**
- Place cursor in VEH DET PLAN [] position and enter "2".

- Place cursor in VEH DETECTOR [] position and enter "1".
- Set delay time to "0".

```

VEH DETECTOR [ 1]  VEH DET PLAN [ 2]
TYPE: S-STANDARD
TS2 DETECTOR..... ECPI LOG..... NO
DET PH - 1 2 3 4 5 6 7 8 9 0 1 2 3 4 5 6
1 1
EXTEND TIME... 0.0 DELAY TIME... 0.0
USE ADDED INITIAL . CROSS SWITCH PH.. 0
LOCK IN..... NONE NTCIP VOL . OR OCC .
PMT QUEUE DELAY. NO
    
```

← NOTICE VEH DET PLAN 2

← ENSURE DELAY IS SET TO '0'

- Place cursor in VEH DETECTOR [] position and enter "26".
- Set assigned phase to "0".

```

VEH DETECTOR [26]  VEH DET PLAN [ 2]
TYPE: S-STANDARD
TS2 DETECTOR..... ECPI LOG..... NO
DET PH - 1 2 3 4 5 6 7 8 9 0 1 2 3 4 5 6
26 0
EXTEND TIME... 0.0 DELAY TIME... 0.0
USE ADDED INITIAL . CROSS SWITCH PH.. 0
LOCK IN..... NONE NTCIP VOL . OR OCC .
PMT QUEUE DELAY. NO
    
```

← NOTICE VEH DET PLAN 2

ENSURE PHASE IS SET TO "0" →

- Place cursor in VEH DETECTOR [] position and enter "5".
- Set delay time to "0".

```

VEH DETECTOR [ 5]  VEH DET PLAN [ 2]
TYPE: S-STANDARD
TS2 DETECTOR..... ECPI LOG..... NO
DET PH - 1 2 3 4 5 6 7 8 9 0 1 2 3 4 5 6
5 5
EXTEND TIME... 0.0 DELAY TIME... 0.0
USE ADDED INITIAL . CROSS SWITCH PH.. 0
LOCK IN..... NONE NTCIP VOL . OR OCC .
PMT QUEUE DELAY. NO
    
```

← NOTICE VEH DET PLAN 2

← ENSURE DELAY IS SET TO '0'

- Place cursor in VEH DETECTOR [] position and enter "22".
- Set assigned phase to "0".

```

VEH DETECTOR [22]  VEH DET PLAN [ 2]
TYPE: S-STANDARD
TS2 DETECTOR..... ECPI LOG..... NO
DET PH - 1 2 3 4 5 6 7 8 9 0 1 2 3 4 5 6
22 0
EXTEND TIME... 0.0 DELAY TIME... 0.0
USE ADDED INITIAL . CROSS SWITCH PH.. 0
LOCK IN..... NONE NTCIP VOL . OR OCC .
PMT QUEUE DELAY. NO
    
```

← NOTICE VEH DET PLAN 2

ENSURE PHASE IS SET TO "0" →

END PROGRAMMING

ECONOLITE ASC/3-2070 OVERLAP PROGRAMMING DETAIL (program controller as shown)

- From Main Menu select **2. CONTROLLER**
- From CONTROLLER Submenu select **2. VEHICLE OVERLAPS**

OVERLAP A

Select TMG VEH OVLP [A] and 'PPLT FYA'

```

TMG VEH OVLP...[A] TYPE: ....PPLT FYA
PROTECTED LEFT TURN... PHASE 1
OPPOSING THROUGH..... PHASE 2

FLASHING ARROW OUTPUT.....CH9 ISOLATE
DELAY START OF: FYA..0.0 CLEARANCE..0.0
ACTION PLAN SF BIT DISABLE..... 1
    
```

← NOTICE ACTION PLAN SF BIT "1"

Toggle Twice

OVERLAP C

Select TMG VEH OVLP [C] and 'PPLT FYA'

```

TMG VEH OVLP...[C] TYPE: ....PPLT FYA
PROTECTED LEFT TURN... PHASE 5
OPPOSING THROUGH..... PHASE 6

FLASHING ARROW OUTPUT.....CH11 ISOLATE
DELAY START OF: FYA..0.0 CLEARANCE..0.0
ACTION PLAN SF BIT DISABLE..... 5
    
```

← NOTICE ACTION PLAN SF BIT "5"

END PROGRAMMING

THIS ELECTRICAL DETAIL IS FOR
THE SIGNAL DESIGN: B-8026
DESIGNED: February 2018
SEALED: 6/7/2018
REVISED: N/A

Electrical Detail - Sheet 2 of 3

DOCUMENT NOT CONSIDERED
FINAL UNLESS ALL
SIGNATURES COMPLETED

<p>Prepared for the Offices of:</p>	<p>N. Mebane Street at S. Beaumont Avenue</p>	<p>SEAL NORTH CAROLINA PROFESSIONAL ENGINEER PAMELA L. ALEXANDER</p>						
<p>Division 7 Alamance County Burlington</p>		<p>6/9/2018</p>						
<p>PLAN DATE: January 2018 REVIEWED BY: AM Encarnacion</p>								
<p>PREPARED BY: NA Ptak REVIEWED BY: PL Alexander</p>								
<table border="1" style="width: 100%; border-collapse: collapse;"> <thead> <tr> <th>REVISIONS</th> <th>INIT.</th> <th>DATE</th> </tr> </thead> <tbody> <tr> <td> </td> <td> </td> <td> </td> </tr> </tbody> </table>		REVISIONS	INIT.	DATE				
REVISIONS	INIT.	DATE						
<p>Signature: Pamela Alexander</p>								
<p>SIG. INVENTORY NO. B-8026</p>								

ALTERNATE PHASING ACTIVATION DETAIL

TO RUN ALT. PHASING DURING FREE RUN - PROGRAM CHANGES (SHOWN BELOW) IN A TIME BASED ACTION PLAN. SCHEDULE A DAY PLAN THAT INCLUDES THE ACTION PLAN PROGRAMMED TO SELECT VEH DET PLAN 2 AND ENABLE SF BITS 1 and 5.

TO RUN ALT. PHASING DURING COORDINATION - SELECT THE TIME BASED ACTION PLAN THAT IS PROGRAMMED TO SELECT VEH DET PLAN 2 AND ENABLE SF BITS 1 and 5.

PHASING	VEH DET PLAN	SF BITS ENABLED
ACTIONS REQUIRED TO RUN <u>DEFAULT PHASING</u>	1	NONE
ACTIONS REQUIRED TO RUN <u>ALTERNATE PHASING</u>	2	1, 5

IMPORTANT: IF ALT. PHASING IS USED DURING FREE RUN AND COORDINATION, DO NOT OPERATE TIME OF DAY EVENTS CONCURRENTLY WITH COORDINATION PLAN EVENTS IN THE EVENT SCHEDULER. (EX. FREE RUN EVENT SHOULD END BEFORE COORDINATION PLAN EVENT STARTS AND VICE-VERSA).

ALTERNATE PHASING CHANGE SUMMARY

THE FOLLOWING IS A SUMMARY OF WHAT TAKES PLACE WHEN SF BITS 1 AND 5 AND VEH DET PLAN 2 ACTIVATE TO CALL THE "ALTERNATE PHASING":

SF BITS 1,5: Modifies overlap parent phases for heads 11 and 51 to run protected turns only.

VEH DET PLAN 2: Disables phase 6 call on loop 1A and reduces delay time for phase 1 call on loop 1A to 0 seconds.

Disables phase 2 call on loop 5A and reduces delay time for phase 5 call on loop 5A to 0 seconds.

ECONOLITE ASC/3-2070 ACTION PLAN PROGRAMMING DETAIL

- From Main Menu select 5. TIME BASE
- From TIME BASE Submenu select 2. ACTION PLAN

```

ACTION PLAN...[ 1]
PATTERN.....AUTO  SYS OVERRIDE.... NO
TIMING PLAN..... 0  SEQUENCE..... 0
VEH DETECTOR PLAN.. 2  DET LOG.....NONE
FLASH..... --  RED REST..... NO
VEH DET DIAG PLN... 0  PED DET DIAG PLN..0
DIMMING ENABLE.. NO  PRIORITY RETURN. NO
PED PR RETURN.. NO  QUEUE DELAY..... NO
PMT COND DELAY  NO
  PHASE  1  2  3  4  5  6  7  8  9  0  1  2  3  4  5  6
PED RCL  .  .  .  .  .  .  .  .  .  .  .  .  .  .  .  .
WALK 2   .  .  .  .  .  .  .  .  .  .  .  .  .  .  .  .
VEX 2    .  .  .  .  .  .  .  .  .  .  .  .  .  .  .  .
VEH RCL  .  .  .  .  .  .  .  .  .  .  .  .  .  .  .  .
MAX RCL  .  .  .  .  .  .  .  .  .  .  .  .  .  .  .  .
MAX 2    .  .  .  .  .  .  .  .  .  .  .  .  .  .  .  .
  PHASE  1  2  3  4  5  6  7  8  9  0  1  2  3  4  5  6
MAX 3    .  .  .  .  .  .  .  .  .  .  .  .  .  .  .  .
CS INH   .  .  .  .  .  .  .  .  .  .  .  .  .  .  .  .
OMIT     .  .  .  .  .  .  .  .  .  .  .  .  .  .  .  .
SPC FCT  X  .  .  .  X  .  .  .  (1-8)
AUX FCT  .  .  .  (1-3)
          1  2  3  4  5  6  7  8  9  0  1  2  3  4  5
LP 1-15  .  .  .  .  .  .  .  .  .  .  .  .  .  .  .  .
LP 16-30 .  .  .  .  .  .  .  .  .  .  .  .  .  .  .  .
LP 31-45 .  .  .  .  .  .  .  .  .  .  .  .  .  .  .  .
LP 46-60 .  .  .  .  .  .  .  .  .  .  .  .  .  .  .  .
LP 61-75 .  .  .  .  .  .  .  .  .  .  .  .  .  .  .  .
LP 76-90 .  .  .  .  .  .  .  .  .  .  .  .  .  .  .  .
LP 91-100 .  .  .  .  .  .  .  .  .  .  .  .  .  .  .  .
    
```

THIS ELECTRICAL DETAIL IS FOR
 THE SIGNAL DESIGN: B-8026
 DESIGNED: February 2018
 SEALED: 6/7/2018
 REVISED: N/A

Electrical Detail - Sheet 3 of 3

DOCUMENT NOT CONSIDERED
FINAL UNLESS ALL
SIGNATURES COMPLETED

ELECTRICAL AND PROGRAMMING DETAILS FOR: Prepared for the Offices of: 	N. Mebane Street at S. Beaumont Avenue	SEAL
Division 7 Alamance County Burlington PLAN DATE: January 2018 REVIEWED BY: AM Encarnacion PREPARED BY: NA Ptak REVIEWED BY: PL Alexander	REVISIONS INIT. DATE _____ _____	6/9/2018 _____ _____ SIG. INVENTORY NO. B-8026

09-JUN-2018 14:17
 D:\Consolidation\Projects\00056469 U-6015 B-C S19 SysTask 05_11_Signal\Des\gn\wlr\ing\B-8026E.dgn
 ALEX3361 AT LUS30649

PHASING DIAGRAM

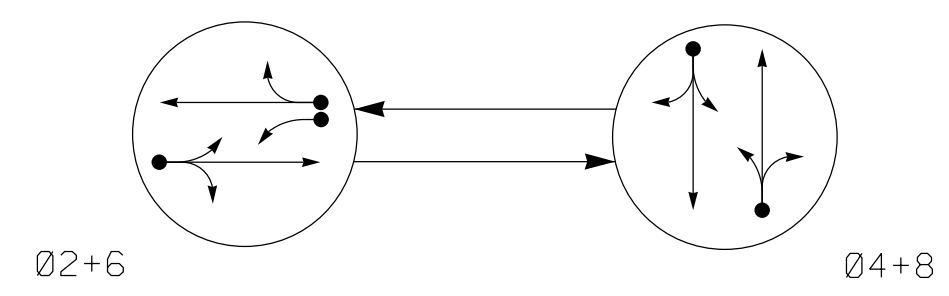

PHASING DIAGRAM DETECTION LEGEND

- DETECTED MOVEMENT
- ◄ UNDETECTED MOVEMENT (OVERLAP)
- ⋯ UNSIGNALIZED MOVEMENT
- ⚡ PEDESTRIAN MOVEMENT

TABLE OF OPERATION

SIGNAL FACE	PHASE		
	02+6	04+8	F L S H
21,22	G	R	Y
41,42	R	G	R
61,62	G	R	Y
81,82	R	G	R

SIGNAL FACE I.D.

All Heads L.E.O.

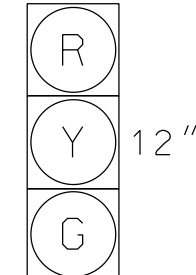

21,22
41,42
61,62
81,82

ASC/3 DETECTOR INSTALLATION CHART

LOOP	SIZE (FT)	DISTANCE FROM STOPBAR (FT)	TURNS	NEW LOOP	PROGRAMMING							
					PHASE	CALLING	EXTEND TIME	DELAY TIME	USE ADDED INITIAL	TYPE	LOOP	NEW CARD
2A	6X40	0	2-4-2	-	2	Yes	-	-	-	S	-	X
4A	6X40	0	2-4-2	-	4	Yes	-	5	-	S	-	X
6A	6X40	+5	2-4-2	-	6	Yes	-	-	-	S	-	X
6B	6X40	+5	2-4-2	-	6	Yes	-	-	-	S	-	X
8A	6X40	0	2-4-2	-	8	Yes	-	3	-	S	-	X
8B	6X20	+10	EXIST	-	8	Yes	-	15	-	S	-	X

2 Phase Fully Actuated (Burlington-Graham Signal System)

NOTES

- Refer to "Roadway Standard Drawings NCDOT" dated January 2018 and "Standard Specifications for Roads and Structures" dated January 2018.
- Do not program signal for late night flashing operation unless otherwise directed by the Engineer.
- Set all detector units to presence mode.
- In the event of loop replacement, refer to the current ITS and Signals Design Manual and submit a Plan of Record to the Signal Design Section.
- Locate new cabinet so as not to obstruct sight distance of vehicles turning right on red.
- Pavement markings are existing.
- Maximum times shown in timing chart are for free-run operation only. Coordinated signal system timing values supersede these values.

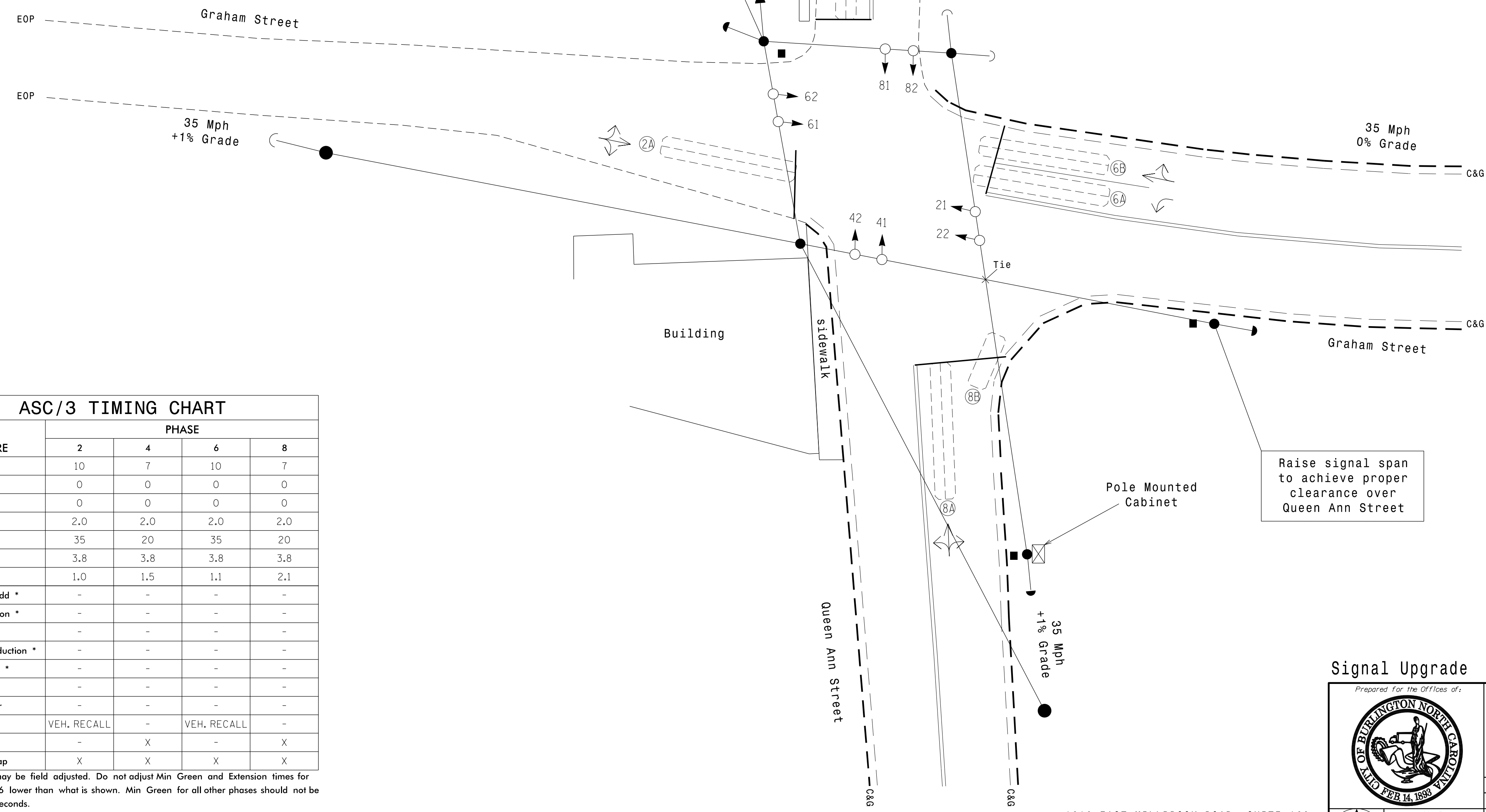

ASC/3 TIMING CHART

FEATURE	PHASE			
	2	4	6	8
Min Green *	10	7	10	7
Walk *	0	0	0	0
Ped Clear	0	0	0	0
Veh. Extension *	2.0	2.0	2.0	2.0
Max 1 *	35	20	35	20
Yellow	3.8	3.8	3.8	3.8
Red Clear	1.0	1.5	1.1	2.1
Actuations B4 Add *	-	-	-	-
Seconds /Actuation *	-	-	-	-
Max Initial *	-	-	-	-
Time Before Reduction *	-	-	-	-
Time To Reduce *	-	-	-	-
Minimum Gap	-	-	-	-
Locking Detector	-	-	-	-
Recall Position	VEH. RECALL	-	VEH. RECALL	-
Dual Entry	-	X	-	X
Simultaneous Gap	X	X	X	X

* These values may be field adjusted. Do not adjust Min Green and Extension times for phases 2 and 6 lower than what is shown. Min Green for all other phases should not be lower than 4 seconds.

LEGEND

PROPOSED	EXISTING
○ Traffic Signal Head	● Traffic Signal Head
◐ Modified Signal Head	N/A
⊥ Sign	⊥ Sign
⊥ Pedestrian Signal Head With Push Button & Sign	⊥ Pedestrian Signal Head
○ Signal Pole with Guy	○ Signal Pole with Guy
○ Signal Pole with Sidewalk Guy	○ Signal Pole with Sidewalk Guy
⊠ Inductive Loop Detector	⊠ Inductive Loop Detector
⊠ Controller & Cabinet	⊠ Controller & Cabinet
□ Junction Box	□ Junction Box
⋯ 2-in Underground Conduit	⋯ 2-in Underground Conduit
N/A Right of Way	⋯ Right of Way
→ Directional Arrow	→ Directional Arrow

Signal Upgrade

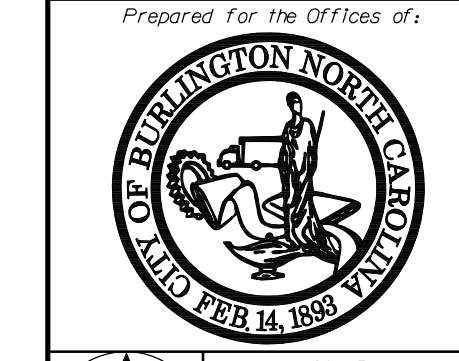

DOCUMENT NOT CONSIDERED FINAL UNLESS ALL SIGNATURES COMPLETED

Graham Street at Queen Ann Street

Division 7 Alamance County Burlington

PLAN DATE: August 2017 REVIEWED BY: AM Encarnacion

PREPARED BY: NA Ptak REVIEWED BY: MB Toth

REVISIONS INIT. DATE

SCALE 0 20 1"=20'

Seal: NORTH CAROLINA PROFESSIONAL ENGINEER SEAL 025892 MELISSA B. TOOTH

6/7/2018

SIG. INVENTORY NO. B-8027

07-JUN-2018 11:15 D:\Projects\Burlington\Traffic\00056469 U-6015 B-G S19 System\Task 05_11_Signal\Des\gpm8-8027.dgn ALEX3361 AT LUS510689

EDI MODEL 2018EClip-NC CONFLICT MONITOR PROGRAMMING DETAIL

(remove jumpers and set switches as shown)

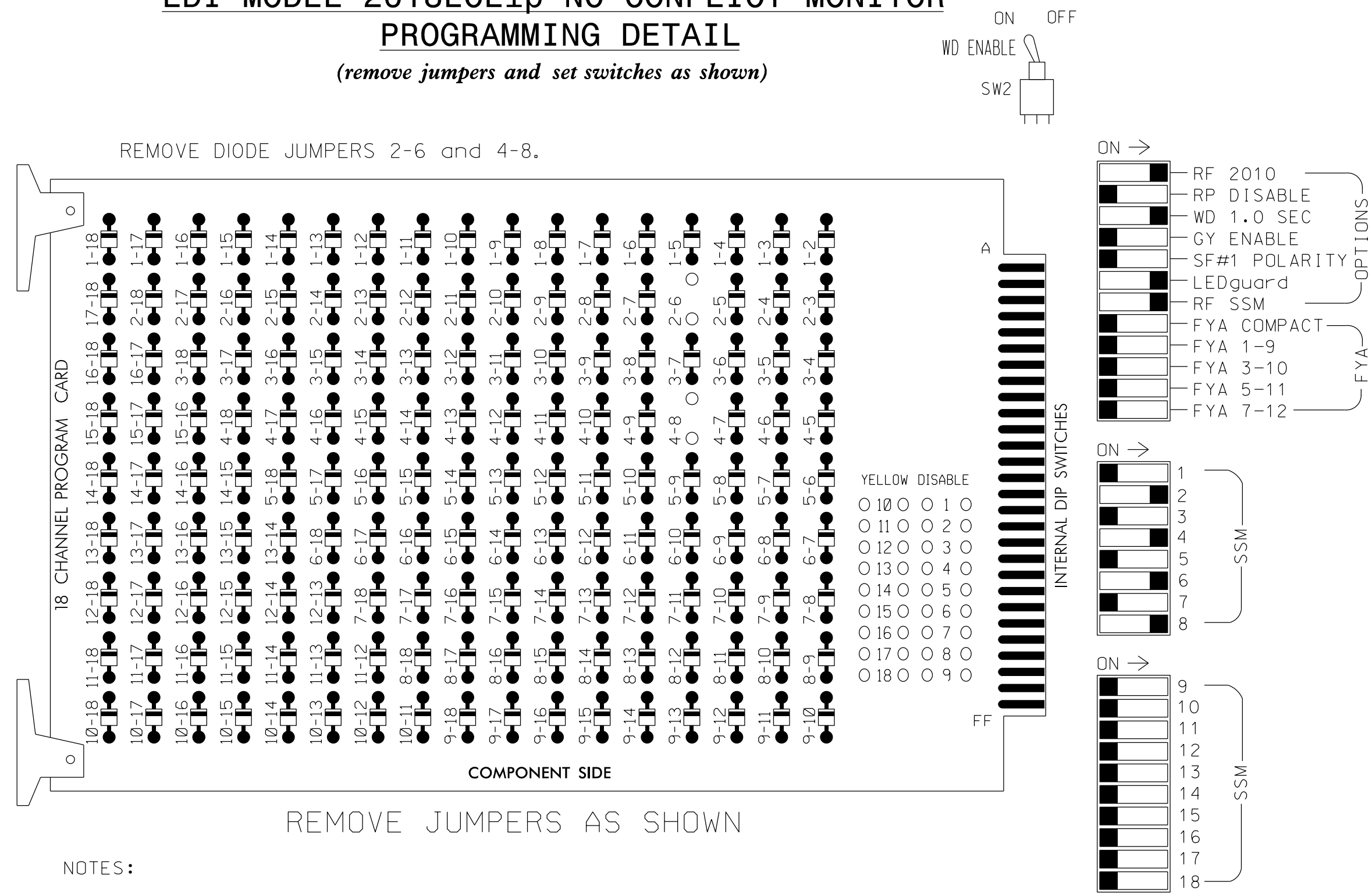

NOTES:

- Card is provided with all diode jumpers in place. Removal of any jumper allows its channels to run concurrently.
- Ensure jumpers SEL2-SEL5 and SEL9 are present on the monitor board.
- Ensure that Red Enable is active at all times during normal operation.
- Integrate monitor with Ethernet network in cabinet.

NOTES

- To prevent "flash-conflict" problems, insert red flash program blocks for all unused vehicle load switches in the output file. The installer shall verify that signal heads flash in accordance with the Signal Plans.
- Program phases 4 and 8 for Dual Entry.
- Program controller to start up in phase 2 Green and 6 Green.
- The cabinet and controller are part of the Burlington-Graham System.

EQUIPMENT INFORMATION

CONTROLLER.....2070LX
 CABINET.....336
 SOFTWARE.....ECONOLITE ASC/3-2070
 CABINET MOUNT.....POLE
 OUTPUT FILE POSITIONS...12
 LOAD SWITCHES USED.....S2,S5,S8,S11
 PHASES USED.....2,4,6,8
 OVERLAPS.....NONE

SIGNAL HEAD HOOK-UP CHART

LOAD SWITCH NO.	S1	S2	S3	S4	S5	S6	S7	S8	S9	S10	S11	S12
CMU CHANNEL NO.	1	2	13	3	4	14	5	6	15	7	8	16
PHASE	1	2	2 PED	3	4	4 PED	5	6	6 PED	7	8	8 PED
SIGNAL HEAD NO.	NU	21,22	NU	NU	41,42	NU	NU	61,62	NU	NU	81,82	NU
RED		128			101			134			107	
YELLOW		129			102			135			108	
GREEN		130			103			136			109	
RED ARROW												
YELLOW ARROW												
GREEN ARROW												

NU = Not Used

INPUT FILE POSITION LAYOUT

(front view)

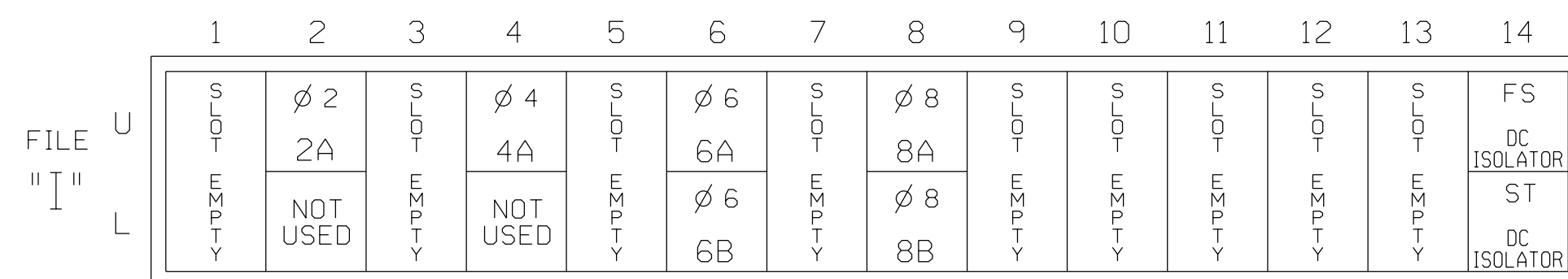

EX.: 1A, 2A, ETC. = LOOP NO.'S

FS = FLASH SENSE
 ST = STOP TIME

INPUT FILE CONNECTION & PROGRAMMING CHART

LOOP NO.	LOOP TERMINAL	INPUT FILE POS.	PIN NO.	DETECTOR NO.	NEMA PHASE	CALL	EXTEND TIME	DELAY TIME	ADDED INITIAL	DETECTOR TYPE
2A	TB21-3,4	I2U	39	2	2	YES				S
4A	TB21-7,8	I4U	41	4	4	YES		5		S
6A	TB21-11,12	I6U	40	6	6	YES				S
6B	TB23-11,12	I6L	44	16	6	YES				S
8A	TB22-1,2	I8U	42	8	8	YES		3		S
8B	TB24-1,2	I8L	46	18	8	YES		15		S

INPUT FILE POSITION LEGEND: J2L

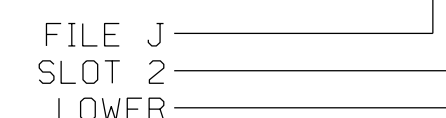

THIS ELECTRICAL DETAIL IS FOR THE SIGNAL DESIGN: B-8027
 DESIGNED: August 2017
 SEALED: 6/7/2018
 REVISED: N/A

Electrical Detail

ELECTRICAL AND PROGRAMMING DETAILS FOR:

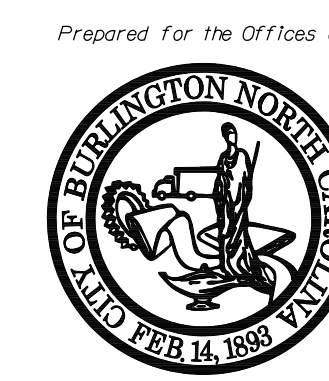

Prepared for the Offices of:

Graham Street at Queen Ann Street

Division 7 Alamance County Burlington

PLAN DATE: August 2017 REVIEWED BY: MB Toth

PREPARED BY: AM Encarnacion REVIEWED BY:

REVISIONS	INIT.	DATE

DOCUMENT NOT CONSIDERED FINAL UNLESS ALL SIGNATURES COMPLETED

SEAL
 NORTH CAROLINA PROFESSIONAL ENGINEER
 SEAL 025892
 MELISSA B. TOTH

Designed by: Melissa B. Toth 6/11/2018
 DATE

SIG. INVENTORY NO. B-8027

EDI MODEL 2018ECLip-NC CONFLICT MONITOR PROGRAMMING DETAIL

(remove jumpers and set switches as shown)

REMOVE DIODE JUMPERS 2-6 and 4-8.

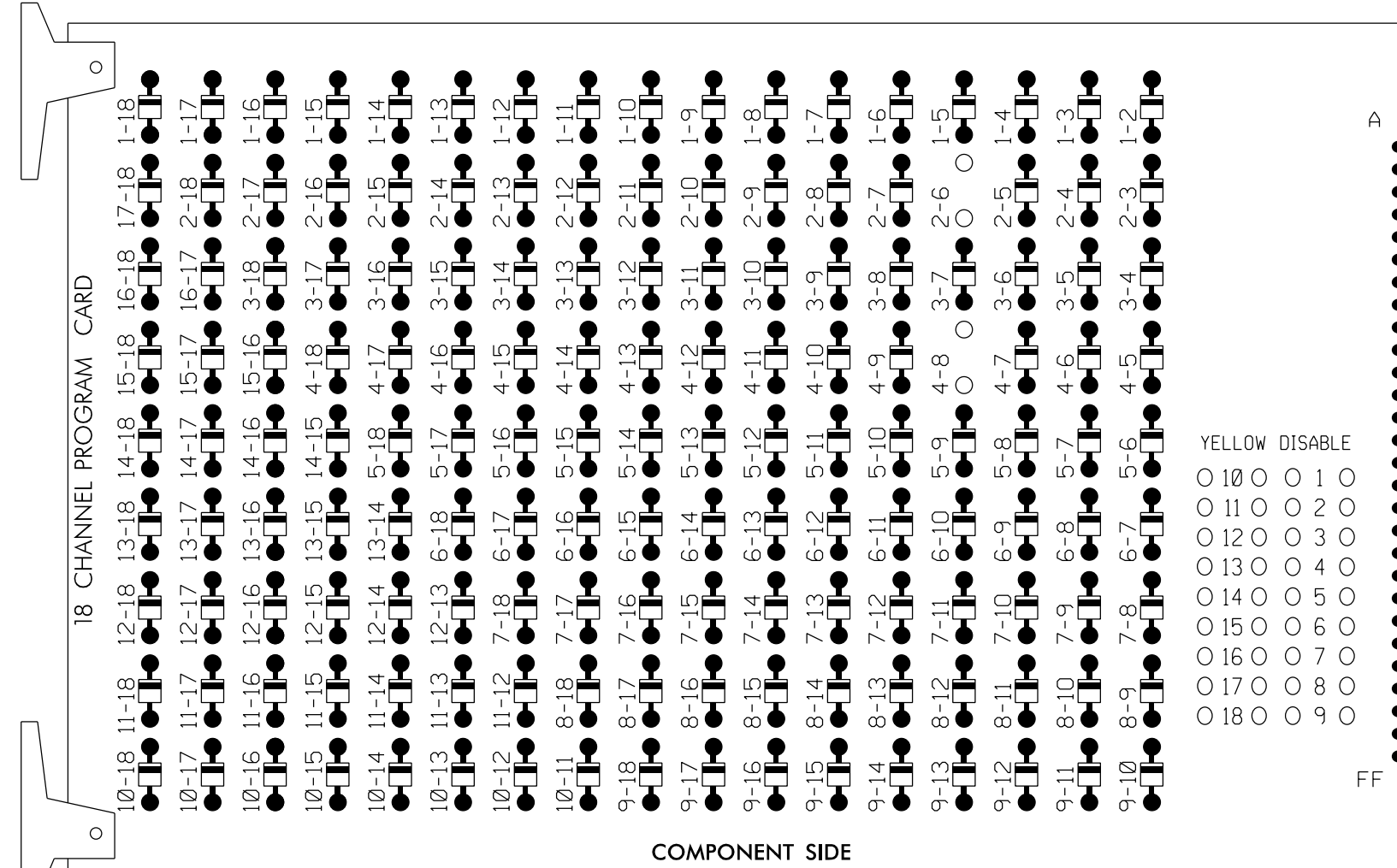

REMOVE JUMPERS AS SHOWN

NOTES:

1. Card is provided with all diode jumpers in place. Removal of any jumper allows its channels to run concurrently.
2. Ensure jumpers SEL2-SEL5 and SEL9 are present on the monitor board.
3. Ensure that Red Enable is active at all times during normal operation.
4. Integrate monitor with Ethernet network in cabinet.

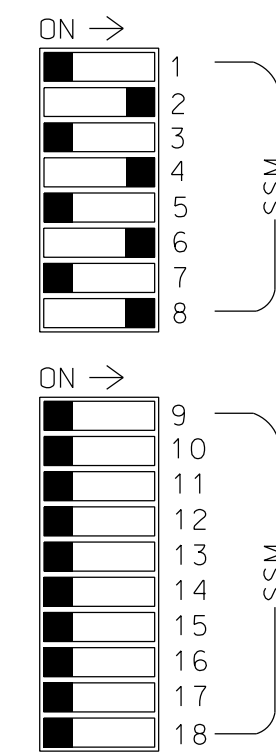
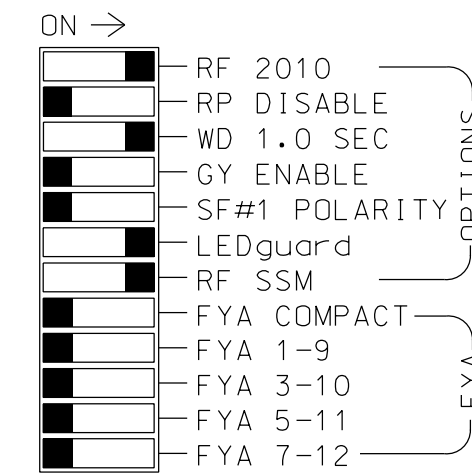
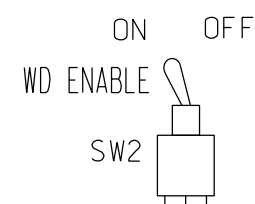

■ = DENOTES POSITION OF SWITCH

NOTES

1. To prevent "flash-conflict" problems, insert red flash program blocks for all unused vehicle load switches in the output file. The installer shall verify that signal heads flash in accordance with the Signal Plans.
2. Program phases 4 and 8 for Dual Entry.
3. Program controller to start up in phase 2 Green and 6 Green.
4. The cabinet and controller are part of the Burlington-Graham System.

EQUIPMENT INFORMATION

CONTROLLER.....2070LX
 CABINET.....332 W/AUX
 SOFTWARE.....ECONDLITE ASC/3-2070
 CABINET MOUNT.....BASE
 OUTPUT FILE POSITIONS...18 WITH AUX. OUTPUT FILE
 LOAD SWITCHES USED.....S2,S5,S8,S11
 PHASES USED.....2,4,6,8
 OVERLAP "A".....NOT USED
 OVERLAP "B".....NOT USED
 OVERLAP "C".....NOT USED
 OVERLAP "D".....NOT USED

SIGNAL HEAD HOOK-UP CHART

LOAD SWITCH NO.	S1	S2	S3	S4	S5	S6	S7	S8	S9	S10	S11	S12	AUX S1	AUX S2	AUX S3	AUX S4	AUX S5	AUX S6
CMU CHANNEL NO.	1	2	13	3	4	14	5	6	15	7	8	16	9	10	17	11	12	18
PHASE	1	2	2 PED	3	4	4 PED	5	6	6 PED	7	8	8 PED	OLA	OLB	SPARE	OLC	OLD	SPARE
SIGNAL HEAD NO.	NU	21,22	NU	NU	41,42	NU	NU	61,62	NU	NU	81,82	NU	NU	NU	NU	NU	NU	NU
RED		128			101			134			107							
YELLOW		129			102			135			108							
GREEN		130			103			136			109							
RED ARROW																		
YELLOW ARROW																		
FLASHING YELLOW ARROW																		
GREEN ARROW																		

NU = Not Used

INPUT FILE POSITION LAYOUT

(front view)

FILE	1	2	3	4	5	6	7	8	9	10	11	12	13	14
U	∅ 2	2A	∅ 3	∅ 4	∅ 5	∅ 6	∅ 7	∅ 8	∅ 9	∅ 10	∅ 11	∅ 12	∅ 13	FS
L	NOT USED		NOT USED	NOT USED	NOT USED	NOT USED	NOT USED	NOT USED	NOT USED	NOT USED	NOT USED	NOT USED	NOT USED	DC ISOLATOR
U	∅ 6	6A	∅ 7	∅ 8	∅ 9	∅ 10	∅ 11	∅ 12	∅ 13	∅ 14	∅ 15	∅ 16	∅ 17	ST
L	NOT USED		NOT USED	NOT USED	NOT USED	NOT USED	NOT USED	NOT USED	NOT USED	NOT USED	NOT USED	NOT USED	NOT USED	DC ISOLATOR

EX.: 1A, 2A, ETC. = LOOP NO.'S

FS = FLASH SENSE
 ST = STOP TIME

INPUT FILE CONNECTION & PROGRAMMING CHART

LOOP NO.	LOOP TERMINAL	INPUT FILE POS.	PIN NO.	DETECTOR NO.	NEMA PHASE	CALL	EXTEND TIME	DELAY TIME	ADDED INITIAL	DETECTOR TYPE
2A	TB2-5,6	I2U	39	2	2	YES				S
4A	TB4-9,10	I6U	41	4	4	YES				S
6A	TB3-5,6	J2U	40	6	6	YES				S
8A	TB5-9,10	J6U	42	8	8	YES				S

INPUT FILE POSITION LEGEND: J2L

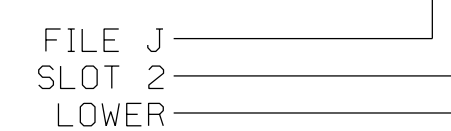

THIS ELECTRICAL DETAIL IS FOR THE SIGNAL DESIGN: B-8451
 DESIGNED: September 2017
 SEALED: 6/7/2018
 REVISED: N/A

Electrical Detail

ELECTRICAL AND PROGRAMMING DETAILS FOR:

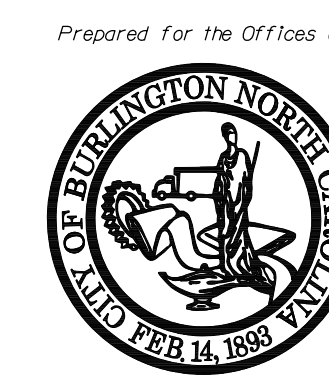

Prepared for the Offices of:
N. Beaumont Avenue at Vaughn Road
 Division 7 Alamance County Burlington
 PLAN DATE: September 2017 REVIEWED BY: AM Encarnacion
 PREPARED BY: NA Ptak REVIEWED BY: MB Toth

REVISIONS	INIT.	DATE

DOCUMENT NOT CONSIDERED FINAL UNLESS ALL SIGNATURES COMPLETED

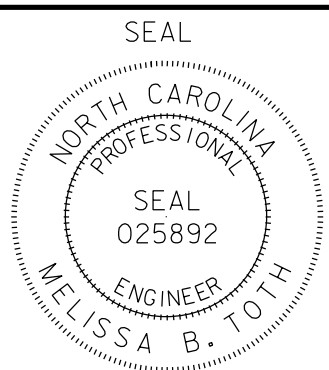

Designed by: Melissa B. Toth DATE: 6/11/2018
 Checked by: DATE: _____
 SIG. INVENTORY NO. B-8451

EDI MODEL 2018ECLip-NC CONFLICT MONITOR PROGRAMMING DETAIL

(remove jumpers and set switches as shown)

REMOVE DIODE JUMPERS 2-6 and 4-8.

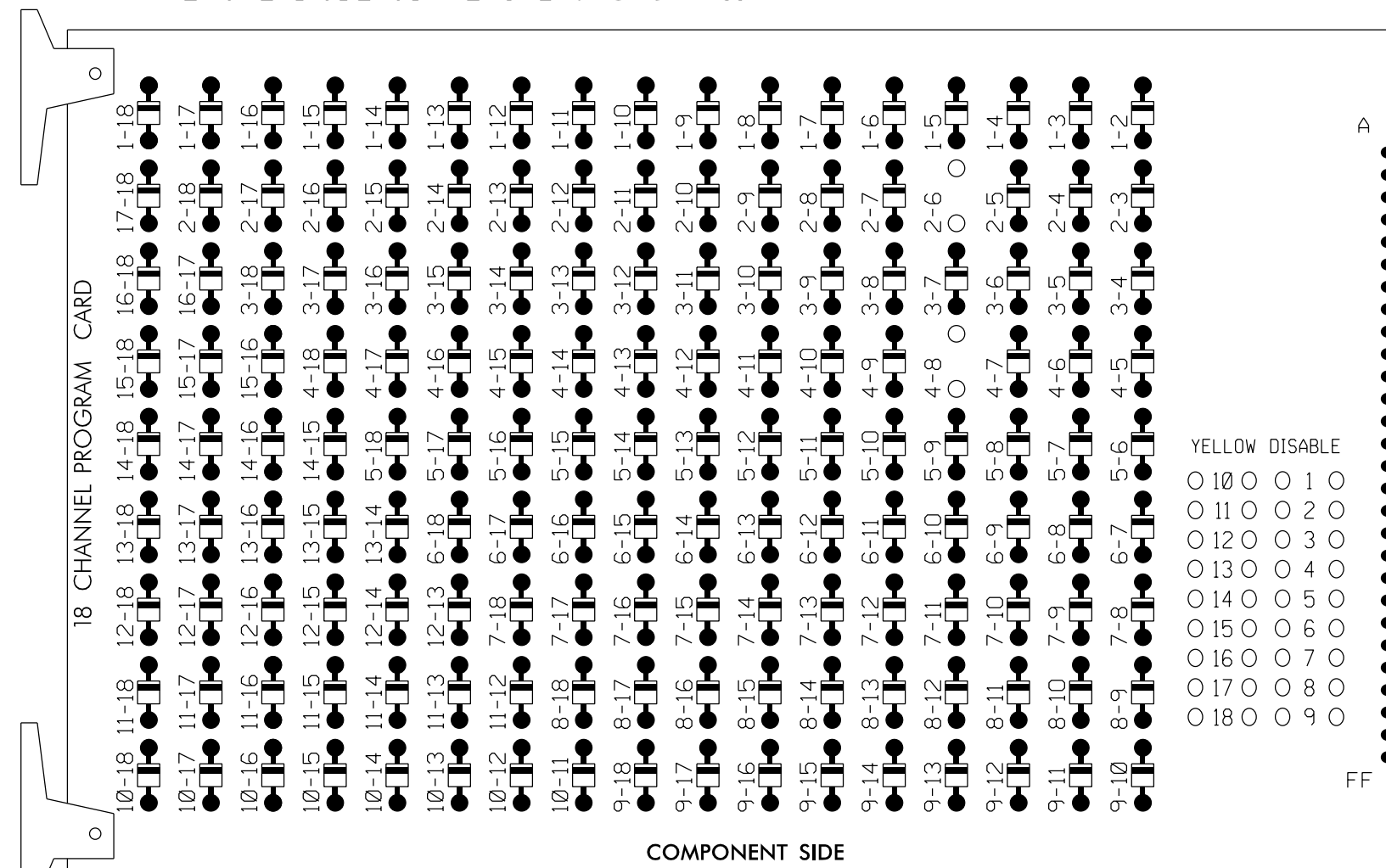

REMOVE JUMPERS AS SHOWN

NOTES:

1. Card is provided with all diode jumpers in place. Removal of any jumper allows its channels to run concurrently.
2. Ensure jumpers SEL2-SEL5 and SEL9 are present on the monitor board.
3. Ensure that Red Enable is active at all times during normal operation.
4. Integrate monitor with Ethernet network in cabinet.

■ = DENOTES POSITION OF SWITCH

NOTES

1. To prevent "flash-conflict" problems, insert red flash program blocks for all unused vehicle load switches in the output file. The installer shall verify that signal heads flash in accordance with the Signal Plans.
2. Program phases 4 and 8 for Dual Entry.
3. Program controller to start up in phase 2 Green and 6 Green.
4. The cabinet and controller are part of the Burlington-Graham Signal System.

EQUIPMENT INFORMATION

CONTROLLER.....2070LX
 CABINET.....332 W/AUX
 SOFTWARE.....ECONDLITE ASC/3-2070
 CABINET MOUNT.....BASE
 OUTPUT FILE POSITIONS...18 WITH AUX. OUTPUT FILE
 LOAD SWITCHES USED.....S2,S5,S8,S11
 PHASES USED.....2,4,6,8
 OVERLAP "A".....NOT USED
 OVERLAP "B".....NOT USED
 OVERLAP "C".....NOT USED
 OVERLAP "D".....NOT USED

SIGNAL HEAD HOOK-UP CHART

LOAD SWITCH NO.	S1	S2	S3	S4	S5	S6	S7	S8	S9	S10	S11	S12	AUX S1	AUX S2	AUX S3	AUX S4	AUX S5	AUX S6
CMU CHANNEL NO.	1	2	13	3	4	14	5	6	15	7	8	16	9	10	17	11	12	18
PHASE	1	2	2 PED	3	4	4 PED	5	6	6 PED	7	8	8 PED	OLA	OLB	SPARE	OLC	OLD	SPARE
SIGNAL HEAD NO.	NU	21,22	NU	NU	41,42	NU	NU	61,62	NU	NU	81,82	NU	NU	NU	NU	NU	NU	NU
RED		128			101			134			107							
YELLOW		129			102			135			108							
GREEN		130			103			136			109							
RED ARROW																		
YELLOW ARROW																		
FLASHING YELLOW ARROW																		
GREEN ARROW																		

NU = Not Used

INPUT FILE POSITION LAYOUT

(front view)

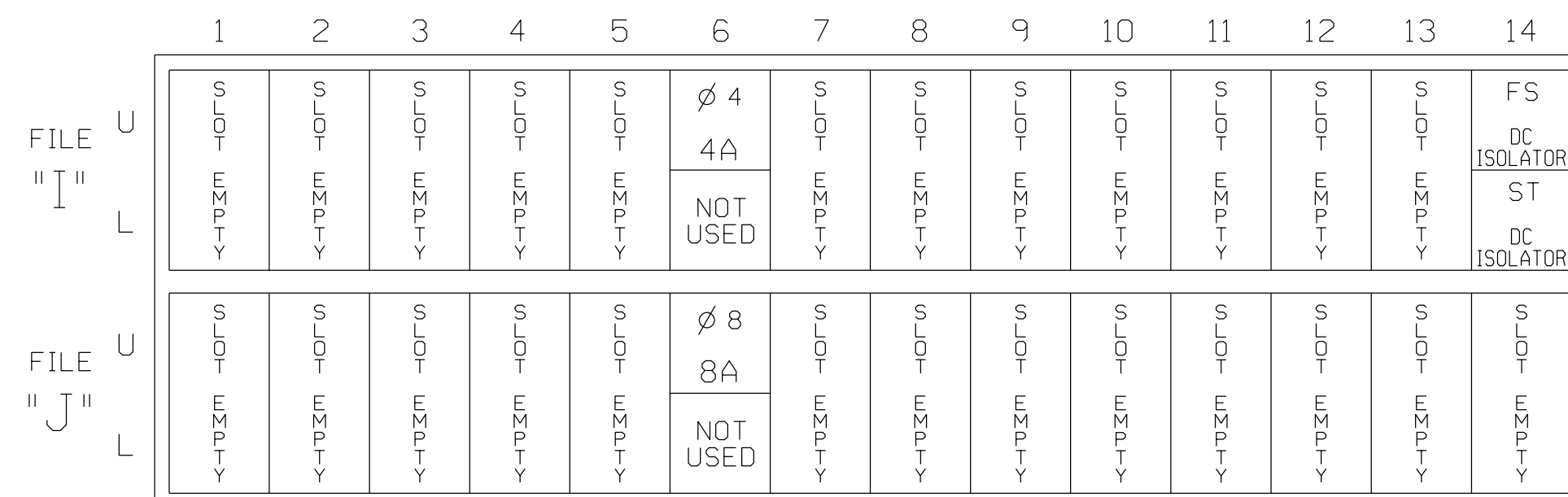

EX. : 1A, 2A, ETC. = LOOP NO.'S

FS = FLASH SENSE
 ST = STOP TIME

INPUT FILE CONNECTION & PROGRAMMING CHART

LOOP NO.	LOOP TERMINAL	INPUT FILE POS.	PIN NO.	DETECTOR NO.	NEMA PHASE	CALL	EXTEND TIME	DELAY TIME	ADDED INITIAL	DETECTOR TYPE
4A	TB4-9,10	I6U	41	4	4	YES		5		S
8A	TB5-9,10	J6U	42	8	8	YES		5		S

INPUT FILE POSITION LEGEND: J2L

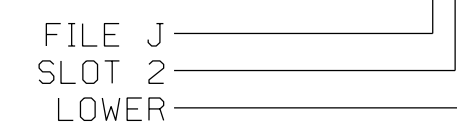

Electrical Detail

ELECTRICAL AND PROGRAMMING DETAILS FOR:

Prepared for the Offices of:

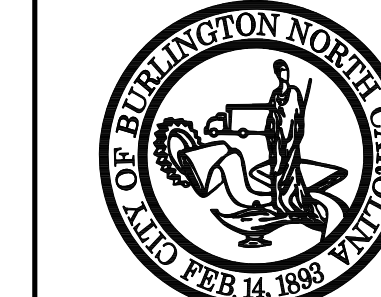

Graham Street
 at
 Beaumont Avenue

Division 7 Alamance County Burlington
 PLAN DATE: August 2017 REVIEWED BY: AM Encarnacion
 PREPARED BY: NA Ptak REVIEWED BY: MB Toth

REVISIONS	INIT.	DATE

DOCUMENT NOT CONSIDERED FINAL UNLESS ALL SIGNATURES COMPLETED

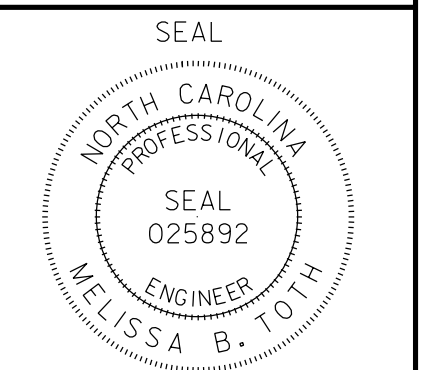

Designed by: Melissa B. Toth 6/11/2018
 CHECKED BY: DATE

SIG. INVENTORY NO. B-8453

PHASING DIAGRAM

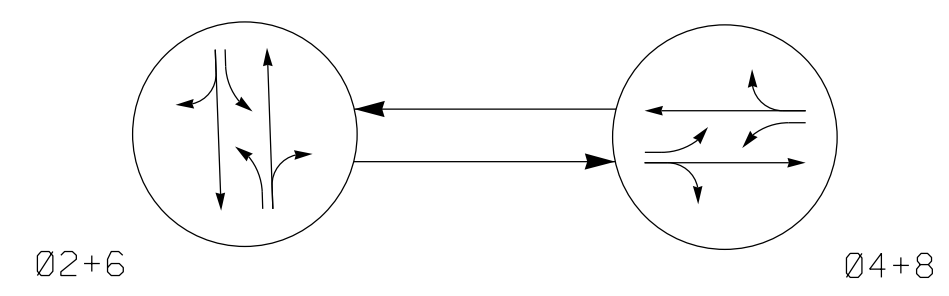

TABLE OF OPERATION

SIGNAL FACE	PHASE		
	02+6	04+8	FLASH
21,22	G	R	Y
41,42	R	G	R
61,62	G	R	Y
81,82	R	G	R

PHASING DIAGRAM DETECTION LEGEND

- ←●→ DETECTED MOVEMENT
- ←→ UNDETECTED MOVEMENT (OVERLAP)
- ←...→ UNSIGNALIZED MOVEMENT
- ←---→ PEDESTRIAN MOVEMENT

SIGNAL FACE I.D.

All Heads L.E.D.

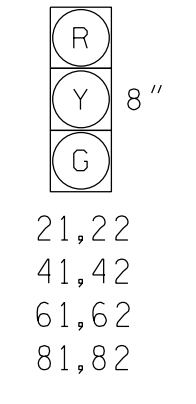

**2 Phase
Pre-Timed
(Burlington-Graham Signal System)**

NOTES

1. Refer to "Roadway Standard Drawings NCDOT" dated January 2018 and "Standard Specifications for Roads and Structures" dated January 2018.
2. Do not program signal for late night flashing operation unless otherwise directed by the Engineer.
3. Locate new cabinet so as not to obstruct sight distance of vehicles turning right on red.
4. Pavement markings are existing.
5. Maximum times shown in timing chart are for free-run operation only. Coordinated signal system timing values supersede these values.

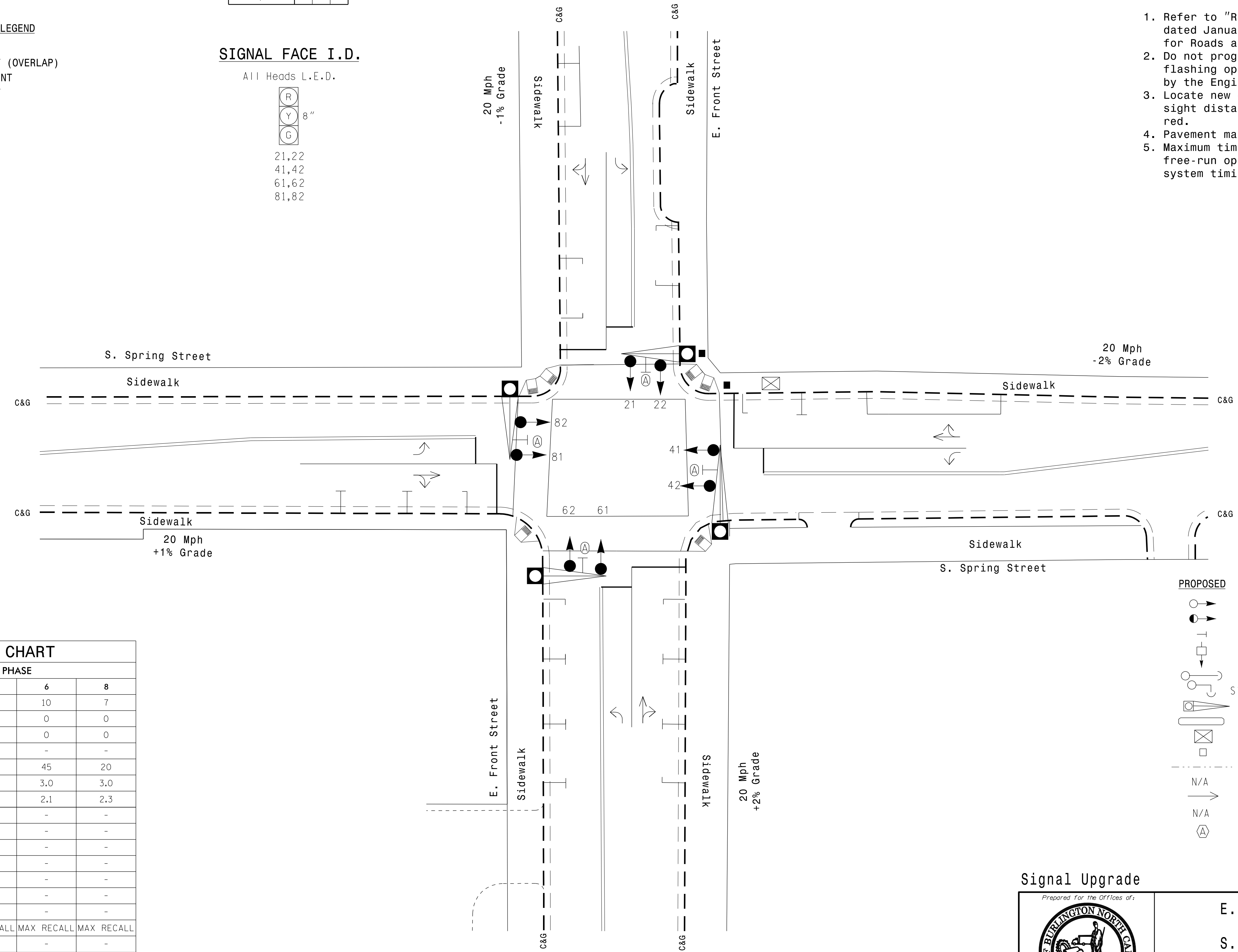

ASC/3 TIMING CHART

FEATURE	PHASE			
	2	4	6	8
Min Green *	10	7	10	7
Walk *	0	0	0	0
Ped Clear	0	0	0	0
Veh. Extension *	-	-	-	-
Max I *	45	20	45	20
Yellow	3.0	3.0	3.0	3.0
Red Clear	2.1	2.3	2.1	2.3
Actuations B4 Add *	-	-	-	-
Seconds /Actuation *	-	-	-	-
Max Initial *	-	-	-	-
Time Before Reduction *	-	-	-	-
Time To Reduce *	-	-	-	-
Minimum Gap	-	-	-	-
Locking Detector	-	-	-	-
Recall Position	MAX RECALL	MAX RECALL	MAX RECALL	MAX RECALL
Dual Entry	-	-	-	-
Simultaneous Gap	X	X	X	X

* These values may be field adjusted. Do not adjust Min Green and Extension times for phases 2 and 6 lower than what is shown. Min Green for all other phases should not be lower than 4 seconds.

LEGEND

PROPOSED	EXISTING
	N/A
N/A	
N/A	

Signal Upgrade

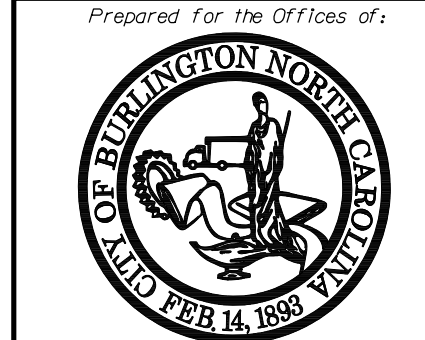

**E. Front Street
at
S. Spring Street**

Division 7 Alamance County Burlington

PLAN DATE: September 2017 REVIEWED BY: AM Encarnacion

PREPARED BY: NA Ptak REVIEWED BY: MB Toth

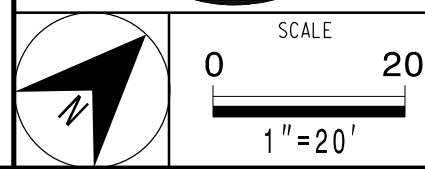
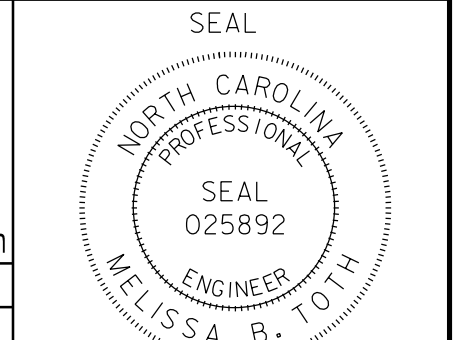

REVISIONS	INIT.	DATE

Designed by: *Melissa B. Toth* 6/7/2018

SIGNATURE: _____ DATE: _____

SIG. INVENTORY NO. B-8454

**DOCUMENT NOT CONSIDERED FINAL
UNLESS ALL SIGNATURES COMPLETED**

07-JUN-2018 11:15 D:\Transpor\at\work\Traffic\curb\00056469 U-6015 B-G S19 System\Task 05_11_Signal\Des\gnme-8454.dgn ALEX3361 AT LUS210649

EDI MODEL 2018ECLip-NC CONFLICT MONITOR PROGRAMMING DETAIL

(remove jumpers and set switches as shown)

REMOVE DIODE JUMPERS 2-6 and 4-8.

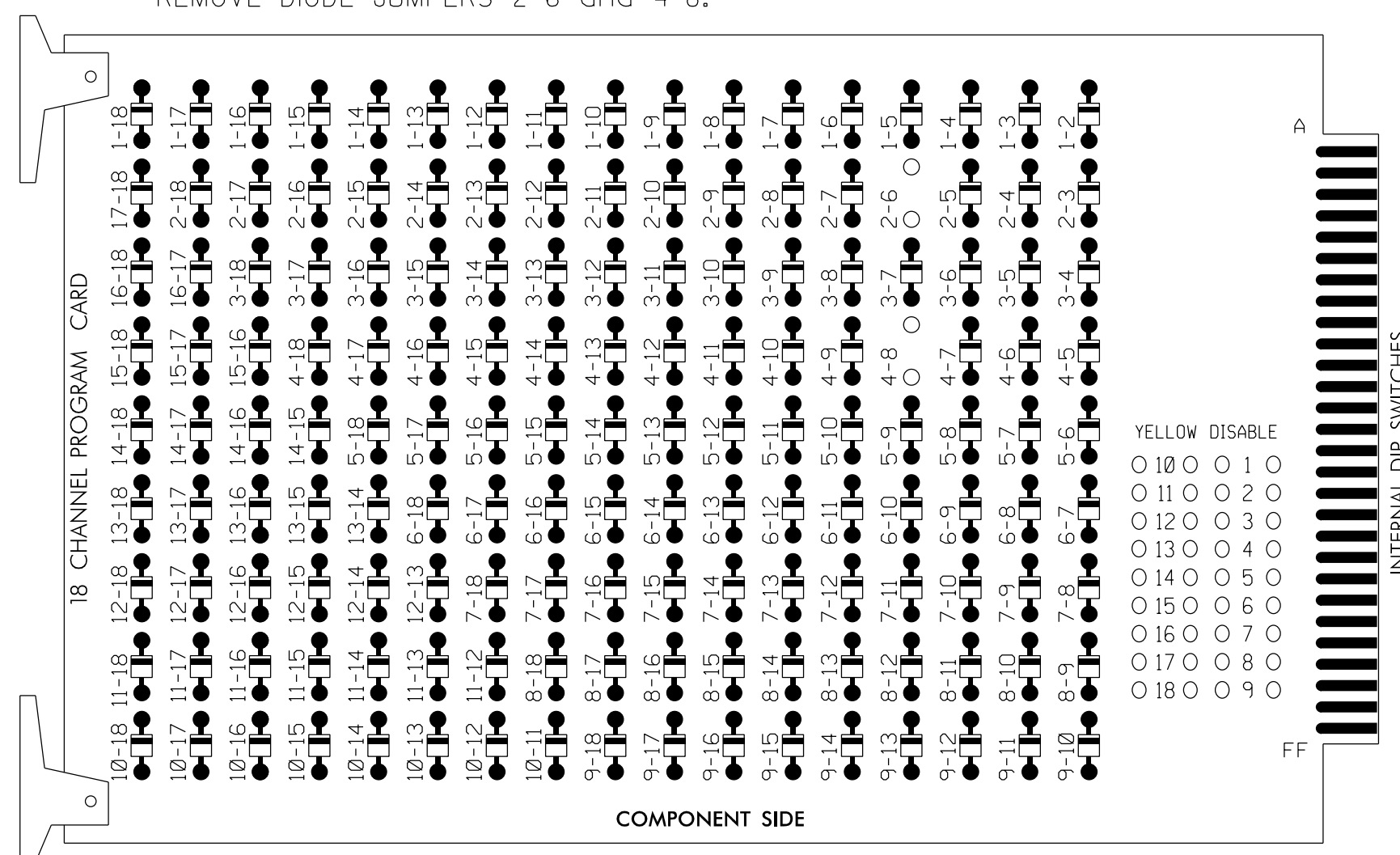

REMOVE JUMPERS AS SHOWN

NOTES:

1. Card is provided with all diode jumpers in place. Removal of any jumper allows its channels to run concurrently.
2. Ensure jumpers SEL2-SEL5 and SEL9 are present on the monitor board.
3. Ensure that Red Enable is active at all times during normal operation.
4. Integrate monitor with Ethernet network in cabinet.

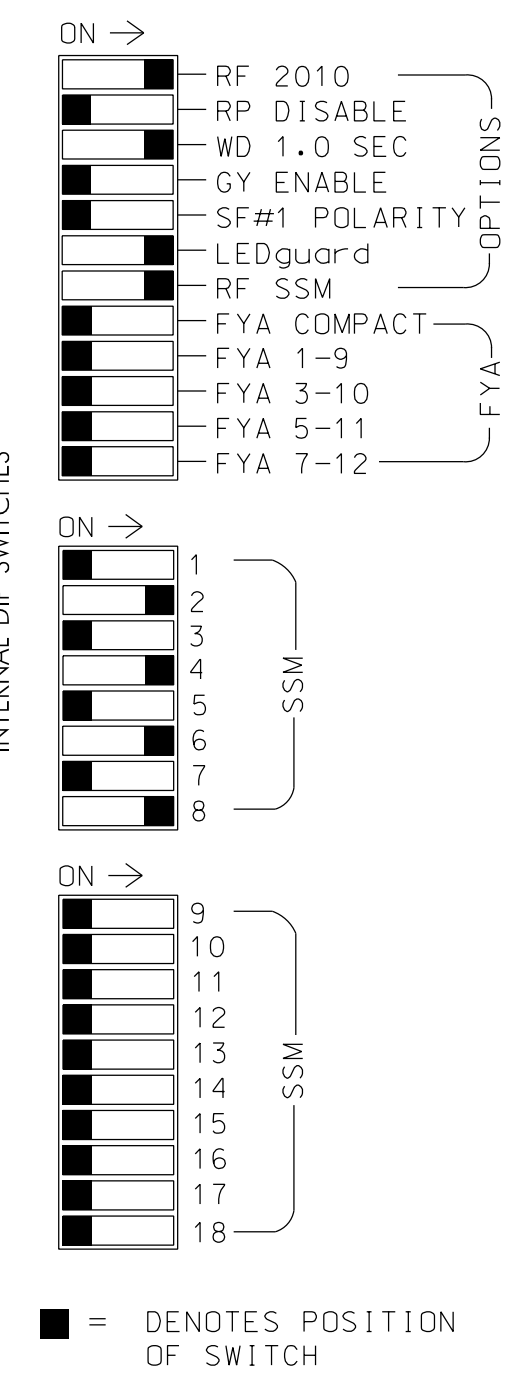
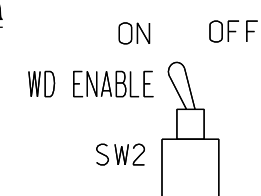

NOTES

1. To prevent "flash-conflict" problems, insert red flash program blocks for all unused vehicle load switches in the output file. The installer shall verify that signal heads flash in accordance with the Signal Plans.
2. Program controller to start up in phase 2 Green and 6 Green.
3. The cabinet and controller are part of the Burlington-Graham Signal System.

EQUIPMENT INFORMATION

CONTROLLER.....2070LX
 CABINET.....336
 SOFTWARE.....ECONOLITE ASC/3-2070
 CABINET MOUNT.....BASE
 OUTPUT FILE POSITIONS...12
 LOAD SWITCHES USED.....S2,S5,S8,S11
 PHASES USED.....2,4,6,8
 OVERLAP "A".....NOT USED
 OVERLAP "B".....NOT USED
 OVERLAP "C".....NOT USED
 OVERLAP "D".....NOT USED

SIGNAL HEAD HOOK-UP CHART

LOAD SWITCH NO.	S1	S2	S3	S4	S5	S6	S7	S8	S9	S10	S11	S12
CMU CHANNEL NO.	1	2	13	3	4	14	5	6	15	7	8	16
PHASE	1	2	2 PED	3	4	4 PED	5	6	6 PED	7	8	8 PED
SIGNAL HEAD NO.	NU	21,22	NU	NU	41,42	NU	NU	61,62	NU	NU	81,82	NU
RED		128			101			134			107	
YELLOW		129			102			135			108	
GREEN		130			103			136			109	
RED ARROW												
YELLOW ARROW												
GREEN ARROW												

NU = Not Used

INPUT FILE POSITION LAYOUT

(front view)

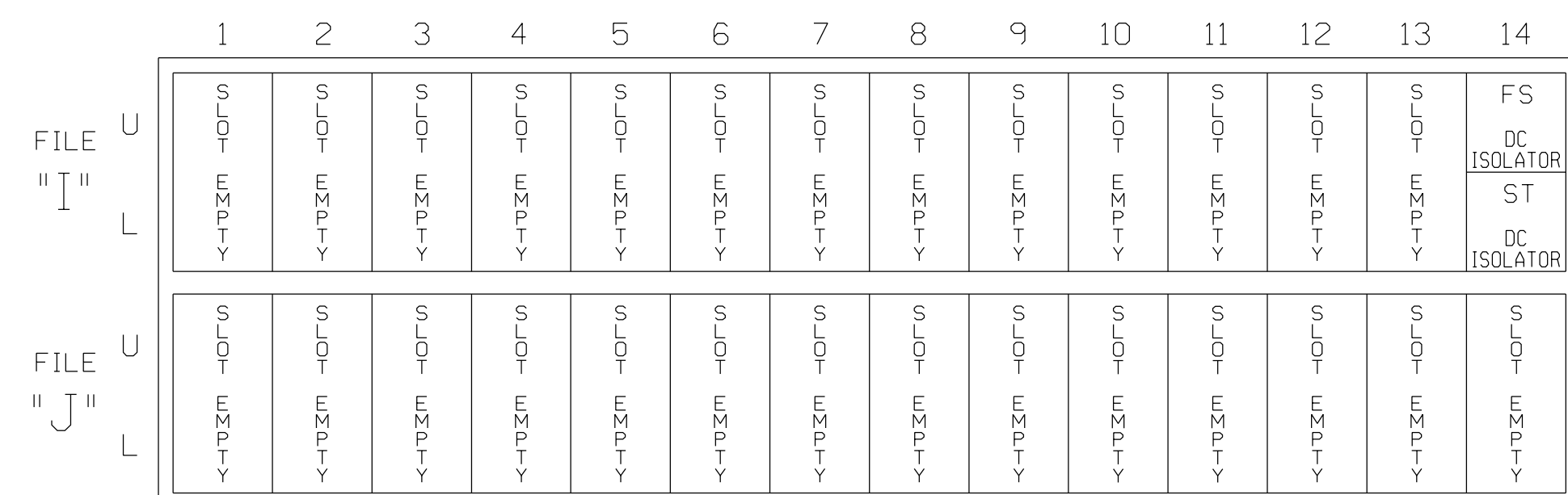

EX. : 1A, 2A, ETC. = LOOP NO.'S

FS = FLASH SENSE
 ST = STOP TIME

THIS ELECTRICAL DETAIL IS FOR THE SIGNAL DESIGN: B-8454
 DESIGNED: September 2017
 SEALED: 6/7/2018
 REVISED: N/A

Electrical Detail

ELECTRICAL AND PROGRAMMING DETAILS FOR:

Prepared for the Offices of:



E. Front Street
 at
 S. Spring Street

Division 7 Alamance County Burlington
 PLAN DATE: September 2017 REVIEWED BY: AM Encarnacion
 PREPARED BY: NA Ptak REVIEWED BY: MB Toth

REVISIONS	INIT.	DATE

DOCUMENT NOT CONSIDERED FINAL UNLESS ALL SIGNATURES COMPLETED

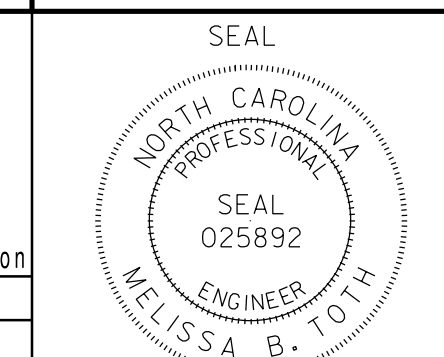

Designed by: Melissa B. Toth 6/11/2018
 Checked/Redlined by: DATE
 SIG. INVENTORY NO. B-8454

ATKINS 1616 EAST MILLBROOK ROAD, SUITE 160
 RALEIGH, NORTH CAROLINA 27609
 (919) 876-6888 NCBES #F-0326

EDI MODEL 2018ECLip-NC CONFLICT MONITOR PROGRAMMING DETAIL

(remove jumpers and set switches as shown)

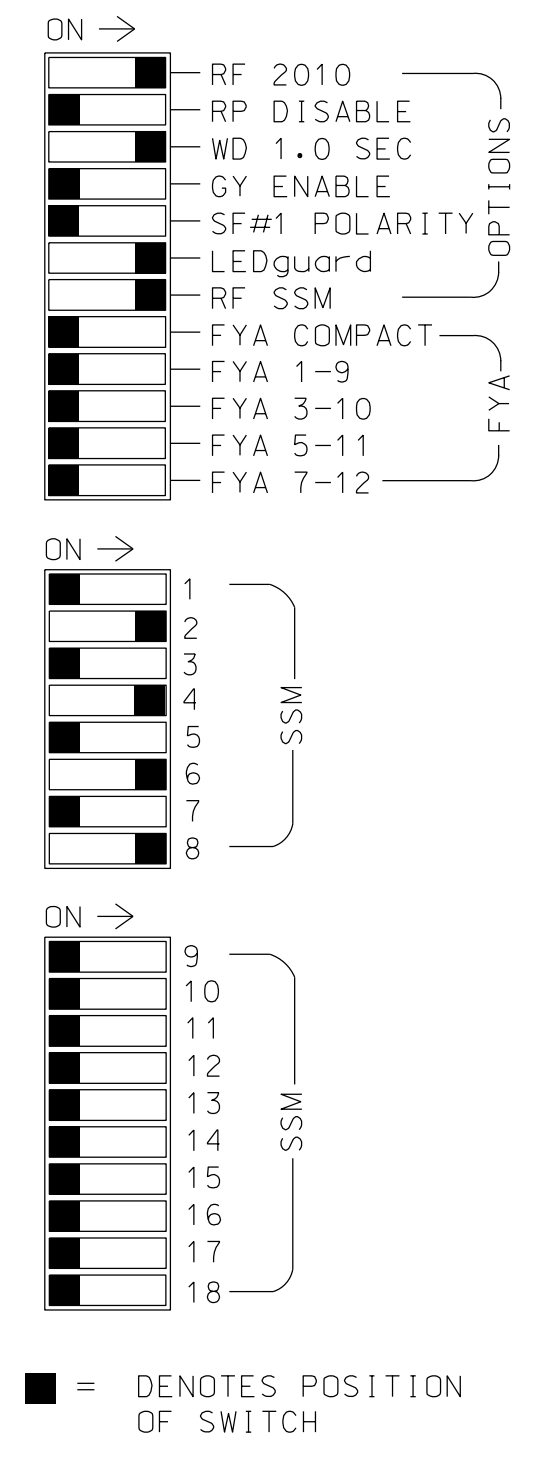
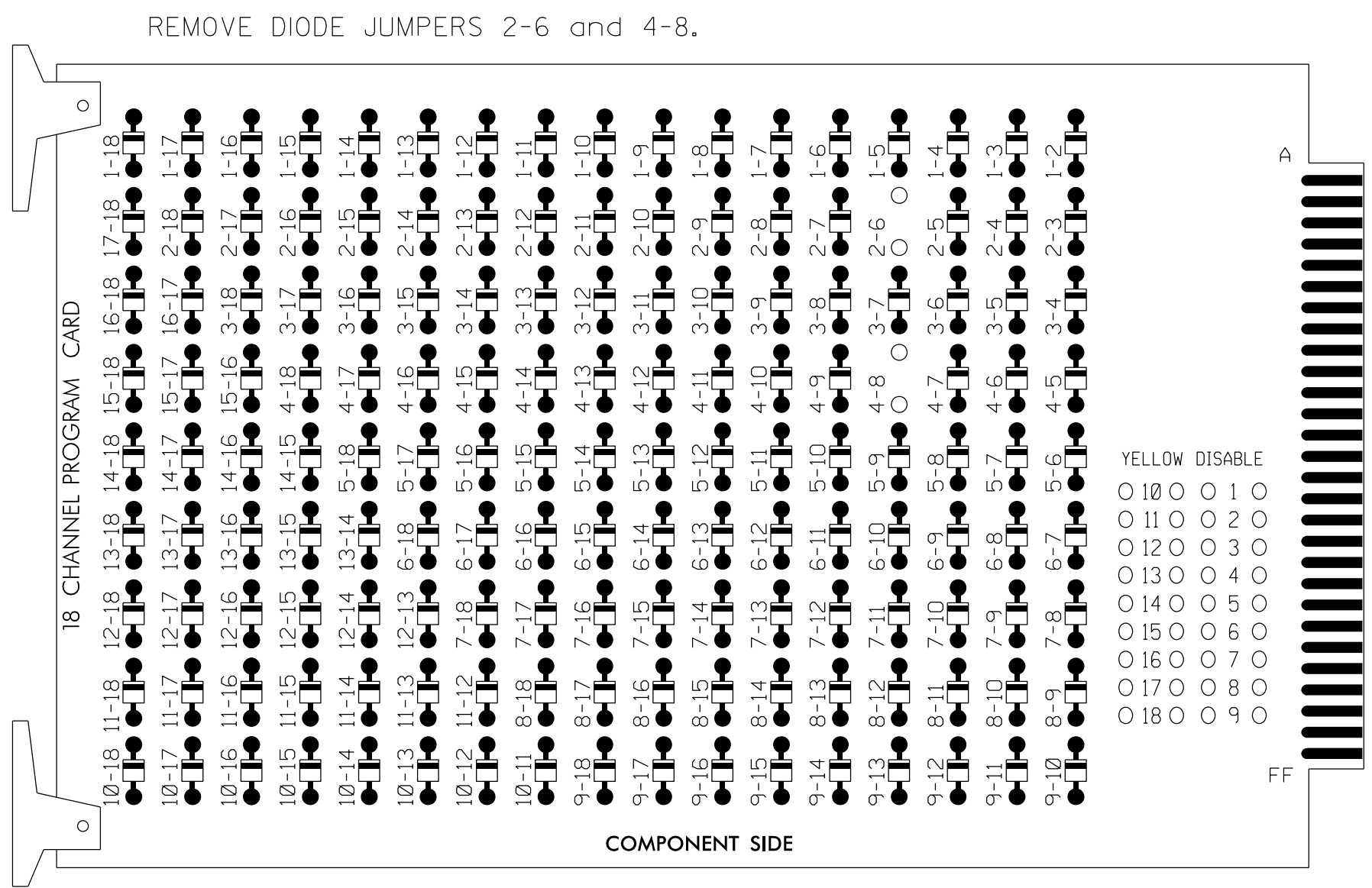
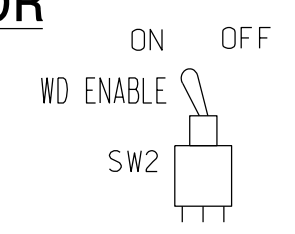

NOTES:

- Card is provided with all diode jumpers in place. Removal of any jumper allows its channels to run concurrently.
- Ensure jumpers SEL2-SEL5 and SEL9 are present on the monitor board.
- Ensure that Red Enable is active at all times during normal operation.
- Integrate monitor with Ethernet network in cabinet.

NOTES

- To prevent "flash-conflict" problems, insert red flash program blocks for all unused vehicle load switches in the output file. The installer shall verify that signal heads flash in accordance with the Signal Plans.
- Program controller to start up in phase 2 Green and 6 Green.
- The cabinet and controller are part of the Burlington-Graham Signal System.

SIGNAL HEAD HOOK-UP CHART

LOAD SWITCH NO.	S1	S2	S3	S4	S5	S6	S7	S8	S9	S10	S11	S12
CMU CHANNEL NO.	1	2	13	3	4	14	5	6	15	7	8	16
PHASE	1	2	2 PED	3	4	4 PED	5	6	6 PED	7	8	8 PED
SIGNAL HEAD NO.	NU	21,22	NU	NU	41,42	NU	NU	61,62	NU	NU	81,82	NU
RED		128			101			134			107	
YELLOW		129			102			135			108	
GREEN		130			103			136			109	
RED ARROW												
YELLOW ARROW												
GREEN ARROW												

NU = Not Used

EQUIPMENT INFORMATION

CONTROLLER.....2070LX
 CABINET.....336
 SOFTWARE.....ECONDLITE ASC/3-2070
 CABINET MOUNT.....BASE
 OUTPUT FILE POSITIONS...12
 LOAD SWITCHES USED.....S2,S5,S8,S11
 PHASES USED.....2,4,6,8
 OVERLAPS.....NONE

INPUT FILE POSITION LAYOUT

(front view)

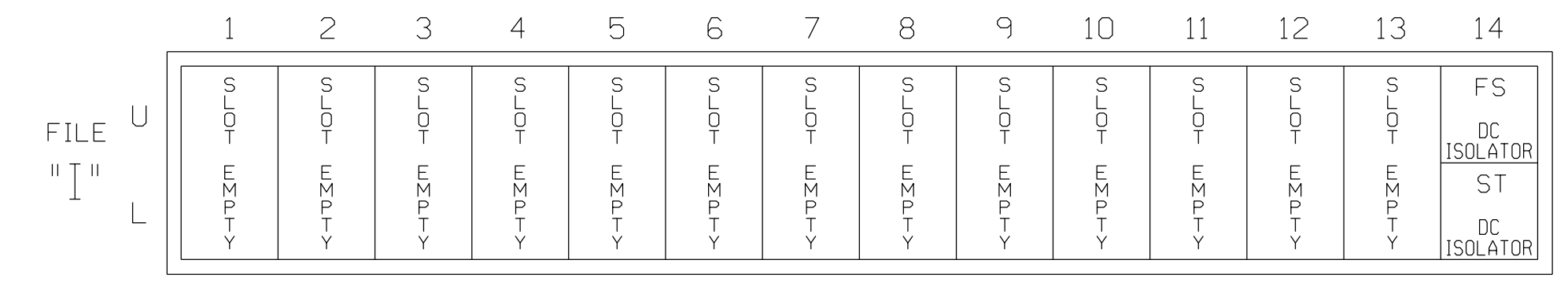

EX.: 1A, 2A, ETC. = LOOP NO.'S

FS = FLASH SENSE
 ST = STOP TIME

THIS ELECTRICAL DETAIL IS FOR THE SIGNAL DESIGN: B8455
 DESIGNED: SEPT-2017
 SEALED: 06-13-2018
 REVISED: N/A

13-JUN-2018 18:05 R:\66015\17\off\c\k\gnols\des\gnw\17\ng\B8455a.dgn KANDERSON AT CHA-KANDERSON



Electrical Detail

E. Davis Street
at
S. Spring Street

Division 7 Alamance County Burlington

PLAN DATE: Sept 2017 REVIEWED BY: AJ Davis
 PREPARED BY: DJ White REVIEWED BY: LM Moon

REVISIONS	INIT.	DATE

DOCUMENT NOT CONSIDERED FINAL UNLESS ALL SIGNATURES COMPLETED

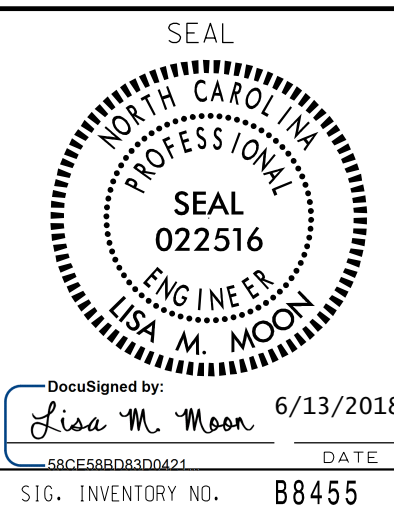

DocuSigned by:
Lisa M. Moon
6/13/2018
DATE
SIG. INVENTORY NO. B8455

EDI MODEL 2018ECLip-NC CONFLICT MONITOR PROGRAMMING DETAIL

(remove jumpers and set switches as shown)

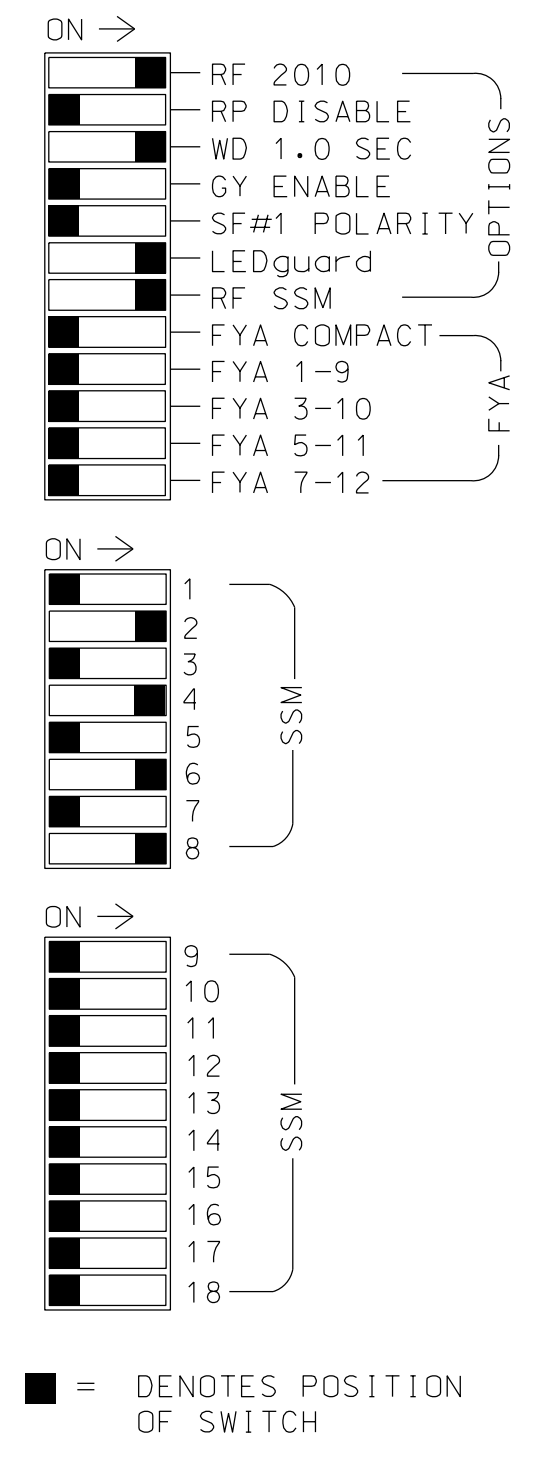
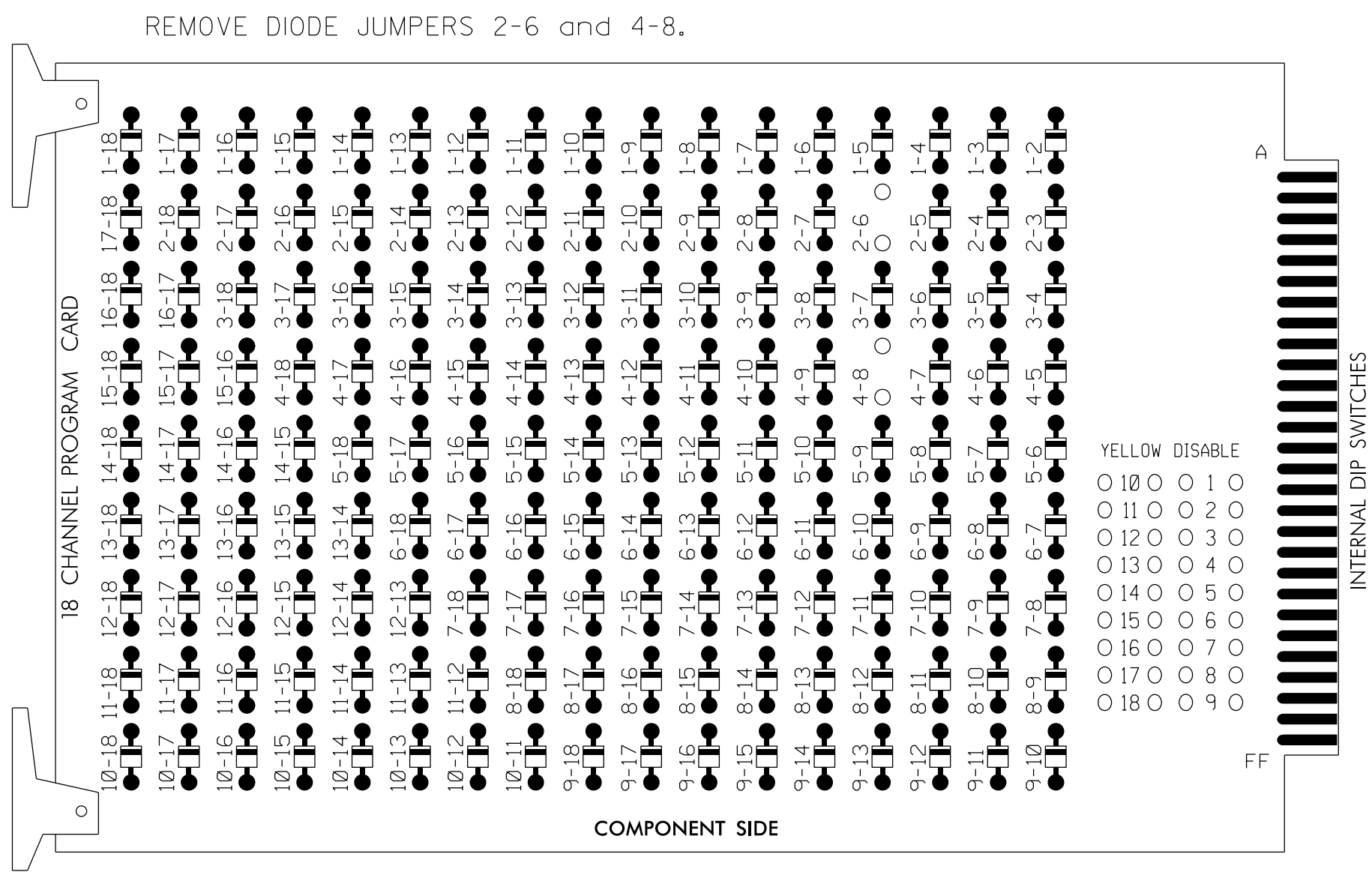
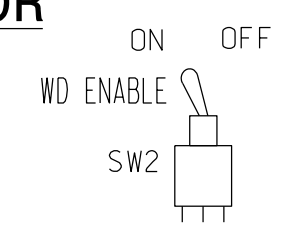

NOTES:

- Card is provided with all diode jumpers in place. Removal of any jumper allows its channels to run concurrently.
- Ensure jumpers SEL2-SEL5 and SEL9 are present on the monitor board.
- Ensure that Red Enable is active at all times during normal operation.
- Integrate monitor with Ethernet network in cabinet.

NOTES

- To prevent "flash-conflict" problems, insert red flash program blocks for all unused vehicle load switches in the output file. The installer shall verify that signal heads flash in accordance with the Signal Plans.
- Program controller to start up in phase 2 Green and 6 Green.
- The cabinet and controller are part of the Burlington-Graham Signal System.

SIGNAL HEAD HOOK-UP CHART

LOAD SWITCH NO.	S1	S2	S3	S4	S5	S6	S7	S8	S9	S10	S11	S12
CMU CHANNEL NO.	1	2	13	3	4	14	5	6	15	7	8	16
PHASE	1	2	2 PED	3	4	4 PED	5	6	6 PED	7	8	8 PED
SIGNAL HEAD NO.	NU	21,22	NU	NU	41,42	NU	NU	61,62	NU	NU	81,82	NU
RED		128			101			134			107	
YELLOW		129			102			135			108	
GREEN		130			103			136			109	
RED ARROW												
YELLOW ARROW												
GREEN ARROW												

NU = Not Used

EQUIPMENT INFORMATION

CONTROLLER.....2070LX
 CABINET.....336
 SOFTWARE.....ECONDLITE ASC/3-2070
 CABINET MOUNT.....BASE
 OUTPUT FILE POSITIONS...12
 LOAD SWITCHES USED.....S2,S5,S8,S11
 PHASES USED.....2,4,6,8
 OVERLAPS.....NONE

INPUT FILE POSITION LAYOUT

(front view)

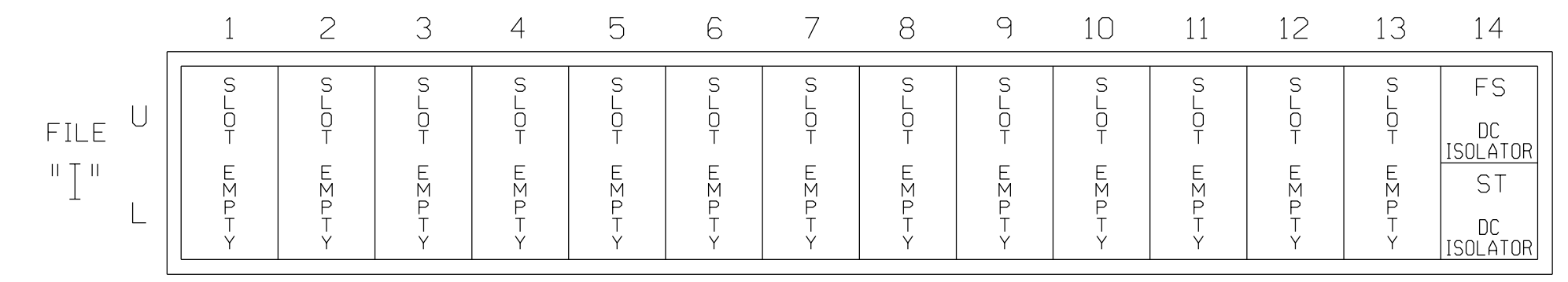

EX.: 1A, 2A, ETC. = LOOP NO.'S

FS = FLASH SENSE
 ST = STOP TIME

THIS ELECTRICAL DETAIL IS FOR THE SIGNAL DESIGN: B8456
 DESIGNED: SEPT-2017
 SEALED: 06-13-2018
 REVISED: N/A

13-Jul-2018 17:55 R:\66015\17\off\caks\gnols\des\gnw\ir\ng\B8456a.dgn C:\pwork AT CAR-RLANTON-W7



Electrical Detail
 S. Lexington Avenue
 at
 E. Davis Street
 Division 7 Alamance County Burlington
 PLAN DATE: Sept 2017 REVIEWED BY: AJ Davis
 PREPARED BY: DJ White REVIEWED BY: LM Moon

DOCUMENT NOT CONSIDERED FINAL UNLESS ALL SIGNATURES COMPLETED

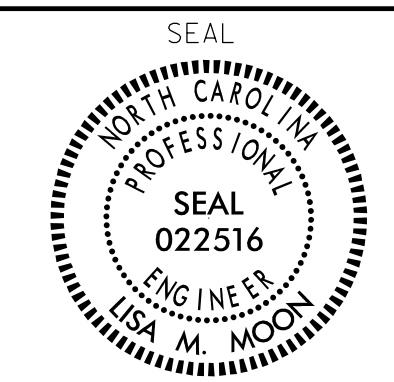

DocuSigned by:
 Lisa M. Moon
 6/13/2018
 DATE
 SIG. INVENTORY NO. B8456

PHASING DIAGRAM

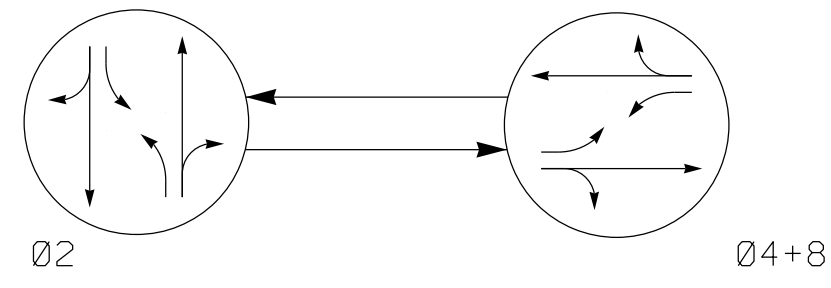

PHASING DIAGRAM DETECTION LEGEND

- ← DETECTED MOVEMENT
- ← UNDETECTED MOVEMENT (OVERLAP)
- ← UNSIGNALIZED MOVEMENT
- ⚡ ← PEDESTRIAN MOVEMENT

TABLE OF OPERATION

SIGNAL FACE	PHASE		
	Ø 2	Ø 4+8	FLASH
21,22,23,24	G	R	Y
41,42	R	G	R
81,82	R	G	R

SIGNAL FACE I.D.

All Heads L.E.D.

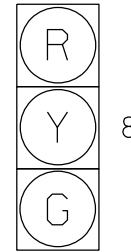

21,22,23,24
41,42
81,82

**2 Phase
Pretimed
(Burlington-Graham Signal System)**

NOTES

- Refer to "Roadway Standard Drawings NCDOT" dated January 2018 and "Standard Specifications for Roads and Structures" dated January 2018.
- Do not program signal for late night flashing operation unless otherwise directed by the Engineer.
- Reposition existing signal heads numbered 21 and 22 to obtain a minimum 8' of separation.
- Locate new cabinet so as not to obstruct sight distance of vehicles turning right on red.
- Pavement markings are existing.
- Maximum times shown in timing chart are for free-run operation only. Coordinated signal system timing values supersede these values.

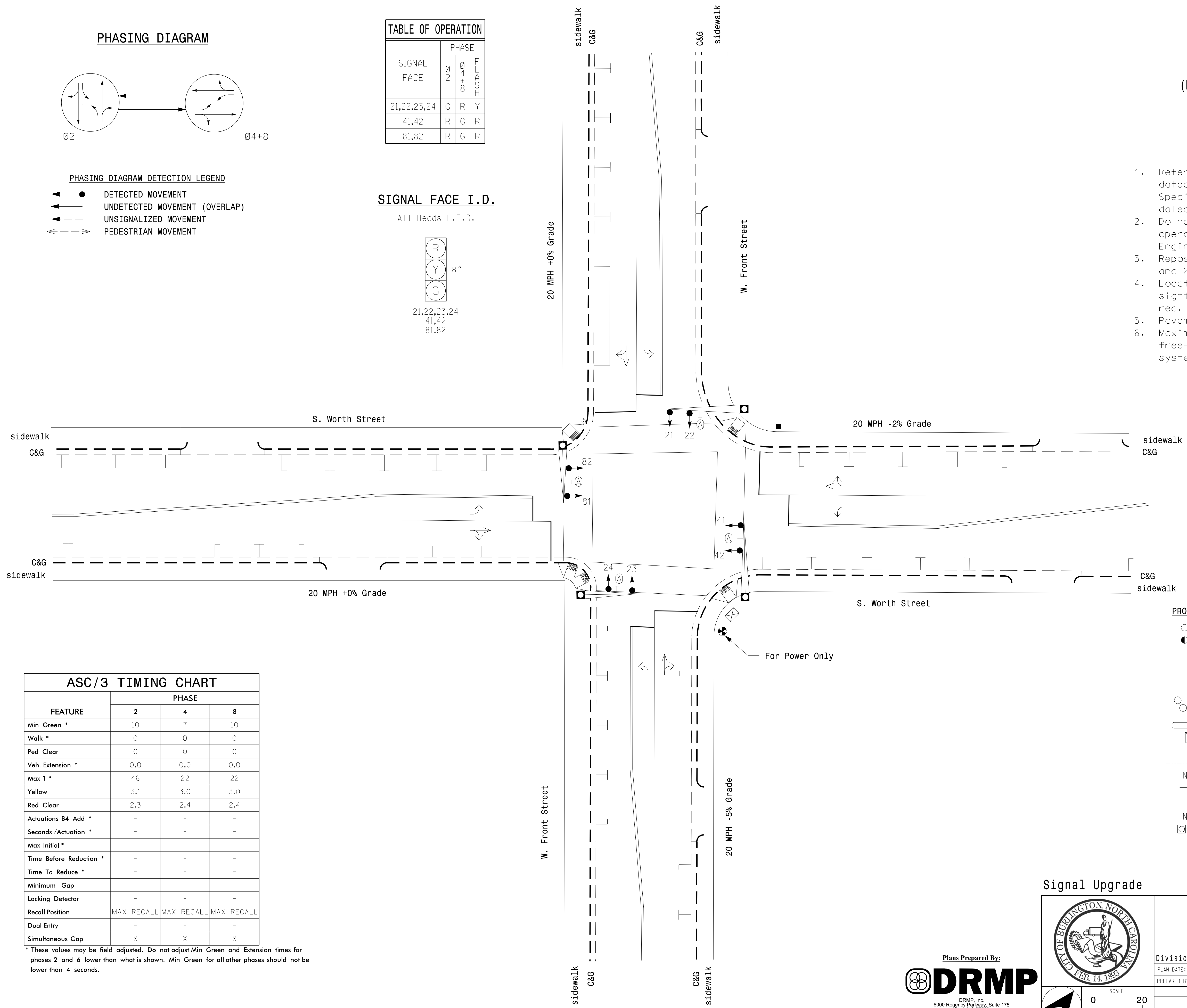

ASC/3 TIMING CHART

FEATURE	PHASE		
	2	4	8
Min Green *	10	7	10
Walk *	0	0	0
Ped Clear	0	0	0
Veh. Extension *	0.0	0.0	0.0
Max 1 *	46	22	22
Yellow	3.1	3.0	3.0
Red Clear	2.3	2.4	2.4
Actuations B4 Add *	-	-	-
Seconds /Actuation *	-	-	-
Max Initial *	-	-	-
Time Before Reduction *	-	-	-
Time To Reduce *	-	-	-
Minimum Gap	-	-	-
Locking Detector	-	-	-
Recall Position	MAX	RECALL	MAX
Dual Entry	-	-	-
Simultaneous Gap	X	X	X

* These values may be field adjusted. Do not adjust Min Green and Extension times for phases 2 and 6 lower than what is shown. Min Green for all other phases should not be lower than 4 seconds.

LEGEND

- | PROPOSED | EXISTING |
|--|---------------------|
| ○ → Traffic Signal Head | ● → N/A |
| ○ → Modified Signal Head | ○ → N/A |
| ○ → Sign | ○ → N/A |
| ○ → Pedestrian Signal Head With Push Button & Sign | ○ → N/A |
| ○ → Type I Pushbutton Post | ○ → N/A |
| ○ → Signal Pole with Guy | ○ → N/A |
| ○ → Signal Pole with Sidewalk Guy | ○ → N/A |
| ○ → Inductive Loop Detector | ○ → N/A |
| ○ → Controller & Cabinet | ○ → N/A |
| ○ → Junction Box | ○ → N/A |
| ○ → 2-in Underground Conduit | ○ → N/A |
| N/A → Right of Way | ○ → N/A |
| → Directional Arrow | → Directional Arrow |
| Ⓐ Street Name Sign | Ⓐ Street Name Sign |
| N/A → Wheelchair Ramp | ○ → N/A |
| ○ → Metal Pole with Mastarm | ○ → N/A |

Signal Upgrade

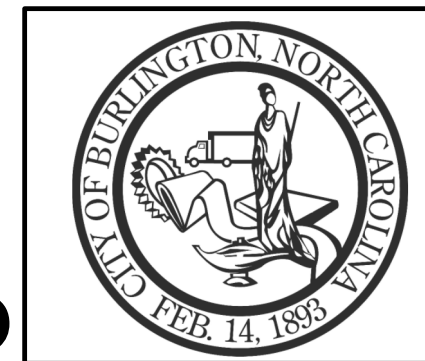

W. Front Street at S. Worth Street

Division 7	Alamance County	Burlington
PLAN DATE: Sept 2017	REVIEWED BY: AJ Davis	
PREPARED BY: RD Lawton	REVIEWED BY: LM Moon	
REVISIONS	INIT.	DATE

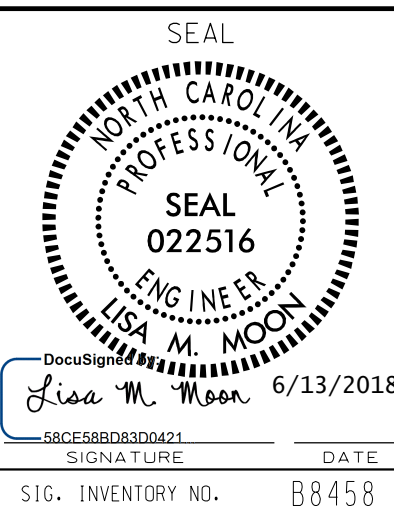

Plans Prepared By:

DRMP, Inc.
8000 Regency Parkway, Suite 175
Cary, NC 27518
NC License No. 5-2213 (919) 650-1038

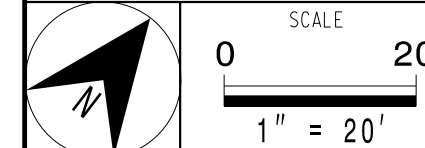

DOCUMENT NOT CONSIDERED FINAL UNLESS ALL SIGNATURES COMPLETED

13-UNA-2018-17-56
R:\66015\17\off\caks\signal\sig\plan\sig\plan\W-Front-AT-C&G-R-LAWTON-W7.dgn

EDI MODEL 2018ECLip-NC CONFLICT MONITOR PROGRAMMING DETAIL

(remove jumper and set switches as shown)

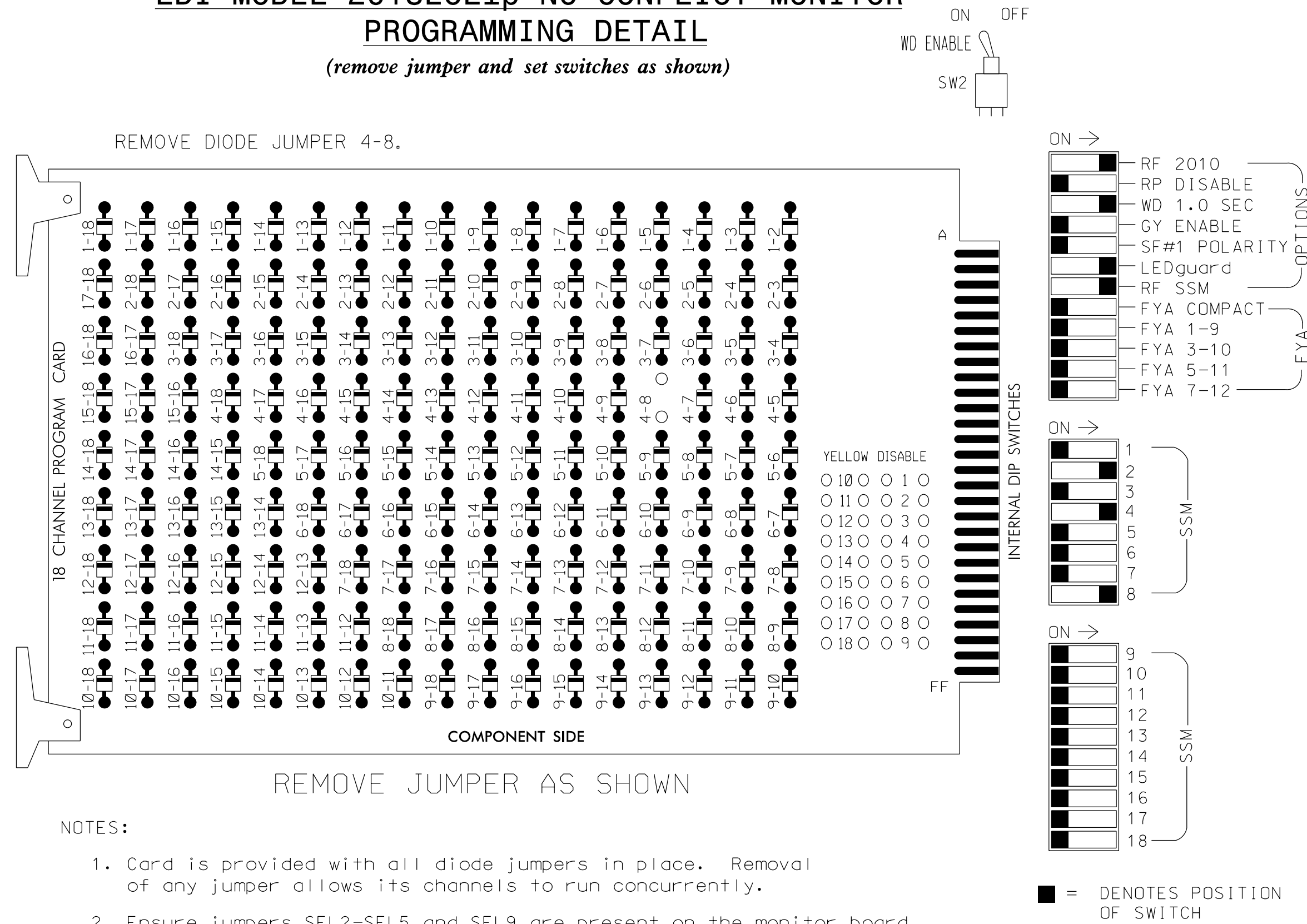

NOTES:

1. Card is provided with all diode jumpers in place. Removal of any jumper allows its channels to run concurrently.
2. Ensure jumpers SEL2-SEL5 and SEL9 are present on the monitor board.
3. Ensure that Red Enable is active at all times during normal operation.
4. Integrate monitor with Ethernet network in cabinet.

NOTES

1. To prevent "flash-conflict" problems, insert red flash program blocks for all unused vehicle load switches in the output file. The installer shall verify that signal heads flash in accordance with the Signal Plans.
2. Program controller to start up in phase 2 Green.
3. The cabinet and controller are part of the Burlington-Graham Signal System.

SIGNAL HEAD HOOK-UP CHART

LOAD SWITCH NO.	S1	S2	S3	S4	S5	S6	S7	S8	S9	S10	S11	S12
CMU CHANNEL NO.	1	2	13	3	4	14	5	6	15	7	8	16
PHASE	1	2	2 PED	3	4	4 PED	5	6	6 PED	7	8	8 PED
SIGNAL HEAD NO.	NU	21,22 23,24	NU	NU	41,42	NU	NU	NU	NU	NU	81,82	NU
RED		128			101						107	
YELLOW		129			102						108	
GREEN		130			103						109	
RED ARROW												
YELLOW ARROW												
GREEN ARROW												

NU = Not Used

EQUIPMENT INFORMATION

CONTROLLER.....2070LX
 CABINET.....336
 SOFTWARE.....ECONDLITE ASC/3-2070
 CABINET MOUNT.....BASE
 OUTPUT FILE POSITIONS...12
 LOAD SWITCHES USED.....S2,S5,S11
 PHASES USED.....2,4,8
 OVERLAPS.....NONE

INPUT FILE POSITION LAYOUT

(front view)

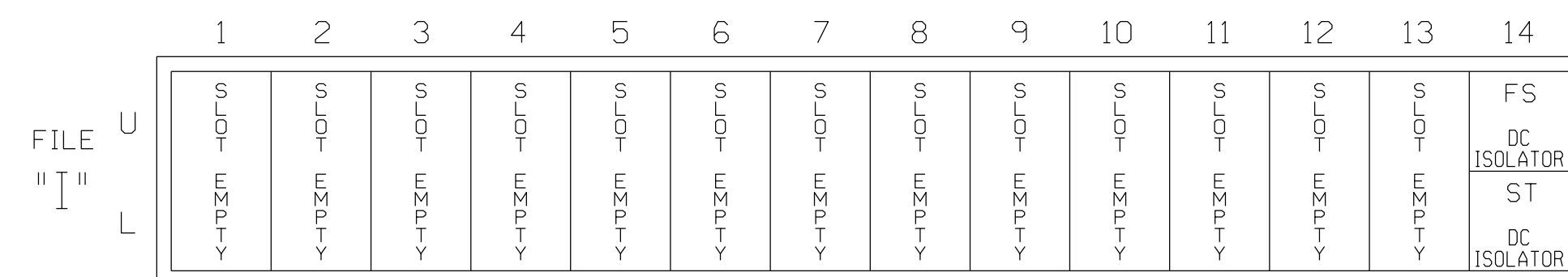

EX.: 1A, 2A, ETC. = LOOP NO.'S

FS = FLASH SENSE
 ST = STOP TIME

THIS ELECTRICAL DETAIL IS FOR THE SIGNAL DESIGN: B8458
 DESIGNED: SEPT-2017
 SEALED: 06-13-2018
 REVISED: N/A

13-UNA-2018-17456
 R:\66015\17\off\esignals\design\wiring\B8458a.dgn
 C:\lowton AT CAR-RLANTON-W7

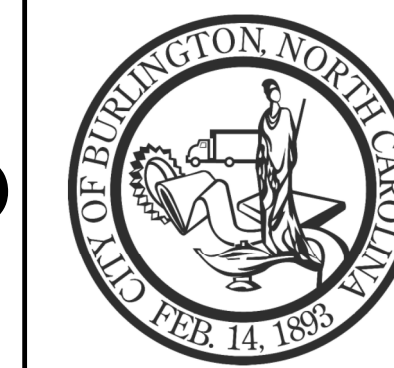

Electrical Detail

ELECTRICAL AND PROGRAMMING DETAILS FOR:

W. Front Street
 at
 S. Worth Street

Division 7 Alamance County Burlington

PLAN DATE: Sept 2017 REVIEWED BY: AJ Davis
 PREPARED BY: DJ White REVIEWED BY: LM Moon

REVISIONS INIT. DATE

DOCUMENT NOT CONSIDERED FINAL UNLESS ALL SIGNATURES COMPLETED

SEAL
 NORTH CAROLINA PROFESSIONAL ENGINEER
 SEAL 022516
 LISA M. MOON

DocuSigned by:
 Lisa M. Moon 6/13/2018
 DATE
 SIG. INVENTORY NO. B8458

PHASING DIAGRAM

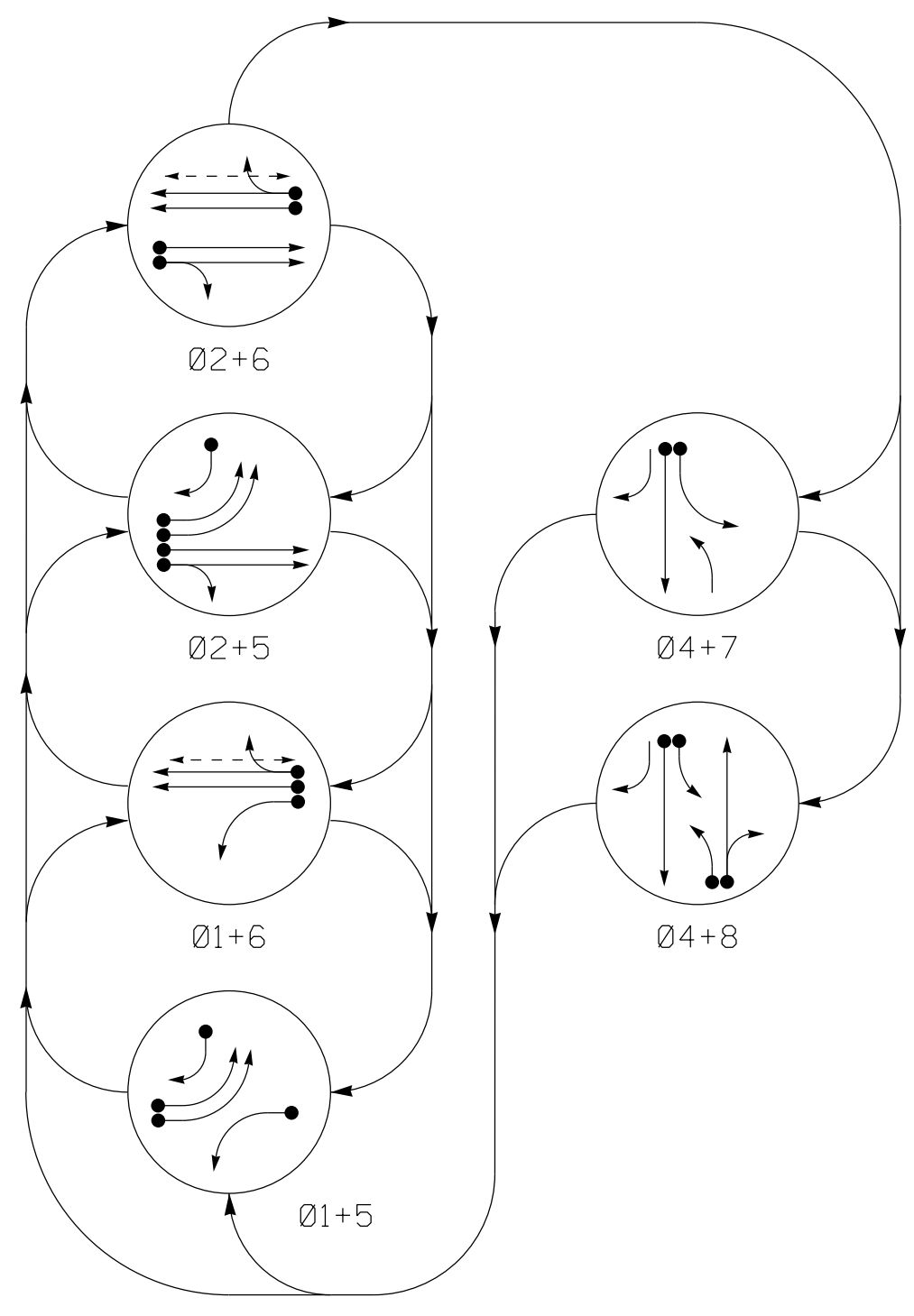

PHASING DIAGRAM DETECTION LEGEND

- DETECTED MOVEMENT
- UNDETECTED MOVEMENT (OVERLAP)
- UNSIGNALIZED MOVEMENT
- PEDESTRIAN MOVEMENT

TABLE OF OPERATION

SIGNAL FACE	PHASE							
	Ø 1+5	Ø 1+6	Ø 2+5	Ø 2+6	Ø 4+7	Ø 4+8	Ø 4+8	Ø 4+8
11	←	←	←	←	←	←	←	←
21,22	R	R	G	G	R	R	Y	
41	R	R	R	R	G	G	R	
42	R	R	R	R	G	G	R	
51,52	←	←	←	←	←	←	←	
61,62	R	G	R	G	R	R	Y	
71	←	←	←	←	←	←	←	
81	←	←	←	←	←	←	←	
82,83	R	R	R	R	R	G	R	
P61,P62	DW	W	DW	W	DW	DRK		

SIGNAL FACE I.D.

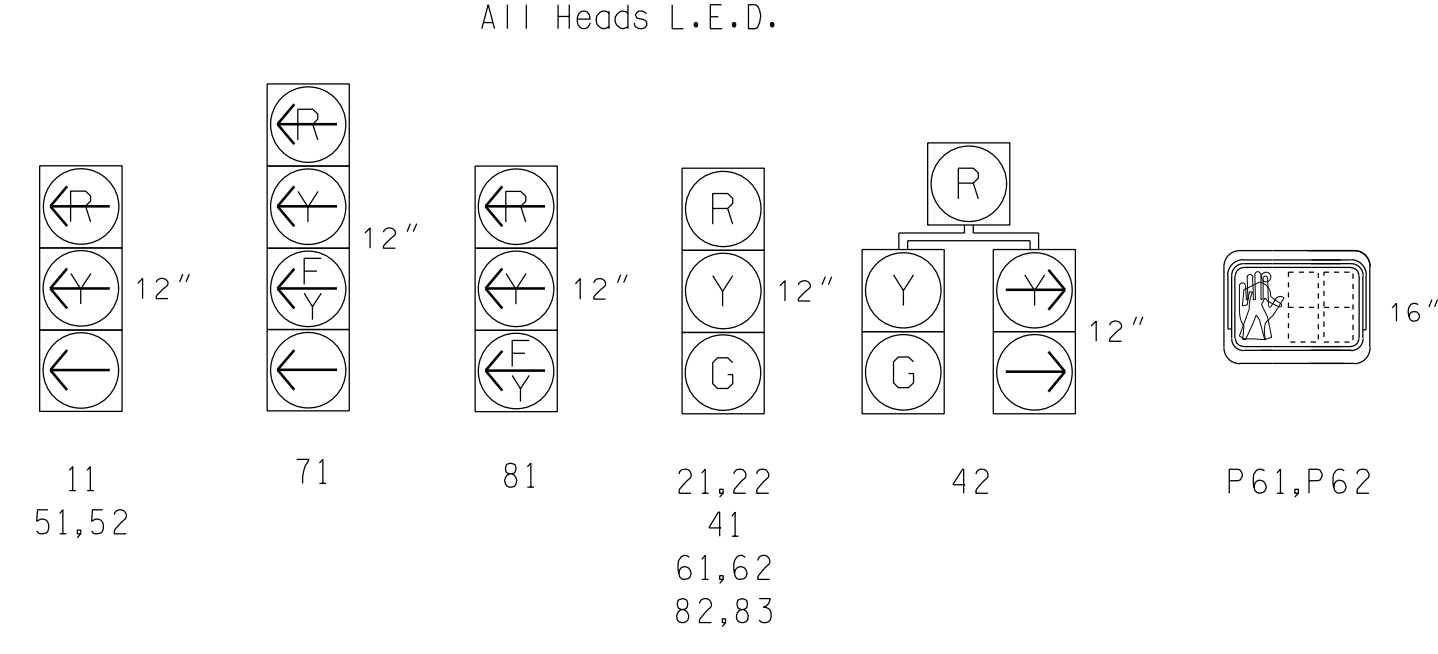

ASC/3 DETECTOR INSTALLATION CHART

LOOP	SIZE (FT)	DISTANCE FROM STOPBAR (FT)	TURNS	NEW LOOP	PROGRAMMING							
					PHASE	CALLING	EXTEND TIME	DELAY TIME	USE ADDED INITIAL	TYPE	LOOP	NEW CARD
1A	6X40	3	2-4-2	-	1	Yes	-	-	-	S	-	X
2A,2B	6X6	80	EXIST	-	2	Yes	-	-	-	S	-	X
4A	6X40	0	2-4-2	-	4	Yes	-	-	-	S	-	X
5A,5B	6X40	0	2-4-2	-	5	Yes	-	-	-	S	-	X
5C	6X40	0	2-4-2	-	5	Yes	-	15	-	S	-	X
6A,6B	6X6	70	EXIST	-	6	Yes	-	-	-	S	-	X
7A	6X40	0	2-4-2	-	7	Yes	-	15	-	S	-	X
8A,8B	6X40	0	2-4-2	-	8	Yes	-	5	-	S	-	X
S1	6X6	+258	EXIST	-	-	No	-	-	-	N	X	X
S2	6X6	+258	EXIST	-	-	No	-	-	-	N	X	X
S3	6X6	+250	EXIST	-	-	No	-	-	-	N	X	X
S4	6X6	+250	EXIST	-	-	No	-	-	-	N	X	X

6 Phase Fully Actuated (Burlington-Graham Signal System)

NOTES

- Refer to "Roadway Standard Drawings NCDOT" dated January 2018 and "Standard Specifications for Roads and Structures" dated January 2018.
- Do not program signal for late night flashing operation unless otherwise directed by Engineer.
- Phase 1 and/or phase 5 may be lagged.
- Reposition existing signal heads numbered 82 and 83.
- Set all detector units to presence mode.
- In the event of loop replacement, refer to the current ITS and Signals Design Manual and submit a Plan of Record to the Signal Design Section.
- Locate new cabinet so as not to obstruct sight distance of vehicles turning right on red.
- Omit "WALK" and flashing "DON'T WALK" with no pedestrian calls.
- Program pedestrian heads to countdown the flashing "DON'T WALK" time only.
- Pavement markings are existing.
- Maximum times shown in timing chart are for free-run operation only. Coordinated signal system timing values supersede these values.

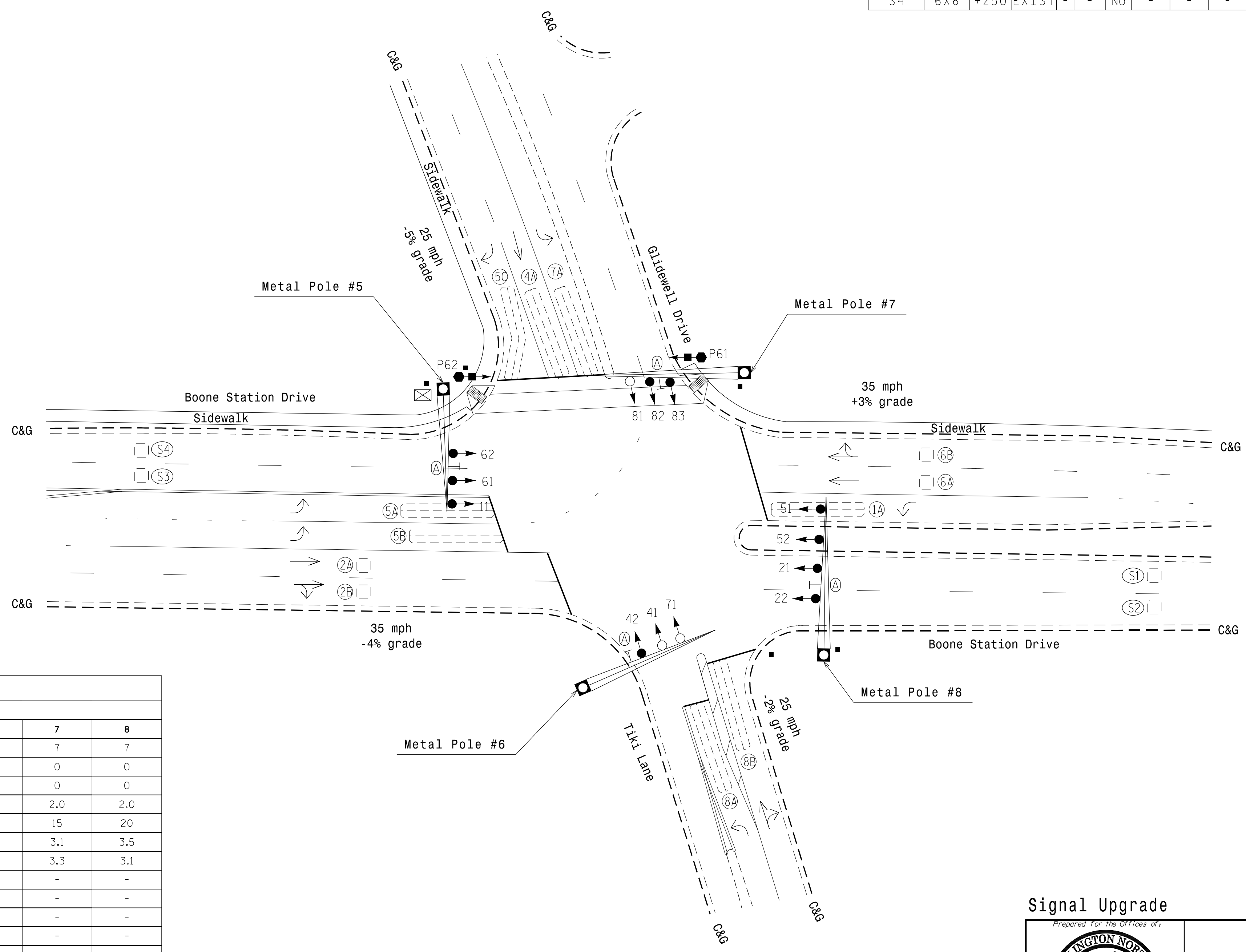

ASC/3 TIMING CHART

FEATURE	PHASE							
	1	2	4	5	6	7	8	
Min Green *	7	10	7	7	10	7	7	
Walk *	0	0	0	0	4	0	0	
Ped Clear	0	0	0	0	23	0	0	
Veh. Extension *	2.0	3.0	2.0	2.0	3.0	2.0	2.0	
Max 1 *	15	40	20	20	40	15	20	
Yellow	3.0	4.1	3.5	3.0	3.7	3.1	3.5	
Red Clear	2.4	1.4	3.1	3.1	1.7	3.3	3.1	
Activations B4 Add *	-	-	-	-	-	-	-	
Seconds / Actuation *	-	-	-	-	-	-	-	
Max Initial *	-	-	-	-	-	-	-	
Time Before Reduction *	-	-	-	-	-	-	-	
Time To Reduce *	-	-	-	-	-	-	-	
Minimum Gap	-	-	-	-	-	-	-	
Locking Detector	-	X	-	-	X	-	-	
Recall Position	-	VEH. RECALL	-	-	VEH. RECALL	-	-	
Dual Entry	-	-	X	-	-	-	X	
Simultaneous Gap	X	X	X	X	X	X	X	

* These values may be field adjusted. Do not adjust Min Green and Extension times for phases 2 and 6 lower than what is shown. Min Green for all other phases should not be lower than 4 seconds.

LEGEND

- | PROPOSED | EXISTING |
|--|--|
| ○ Traffic Signal Head | ● Traffic Signal Head |
| ○ Modified Signal Head | N/A |
| ○ Sign | ○ Sign |
| ○ Pedestrian Signal Head with Push Button & Sign | ○ Pedestrian Signal Head with Push Button & Sign |
| ○ Type II Signal Pedestal | ○ Type II Signal Pedestal |
| ○ Signal Pole with Guy | ○ Signal Pole with Guy |
| ○ Signal Pole with Sidewalk Guy | ○ Signal Pole with Sidewalk Guy |
| ○ Inductive Loop Detector | ○ Inductive Loop Detector |
| ○ Controller & Cabinet | ○ Controller & Cabinet |
| ○ Junction Box | ○ Junction Box |
| ○ 2-in Underground Conduit | ○ 2-in Underground Conduit |
| N/A Right of Way | --- Right of Way |
| → Directional Arrow | → Directional Arrow |
| N/A Curb Ramp | ▲ Curb Ramp |
| ○ Metal Pole with Mastarm | ○ Metal Pole with Mastarm |
| ○ Street Name Sign | ○ Street Name Sign |

Signal Upgrade

Prepared for the Offices of:

Boone Station Drive at Glidewell Drive/Tiki Lane

Division 7 Alamance County Burlington

PLAN DATE: March 2018 REVIEWED BY: PL Alexander

PREPARED BY: NA Ptak REVIEWED BY: AM Encarnacion

REVISIONS: INIT. DATE

SCALE

0 30

1"=30'

DOCUMENT NOT CONSIDERED FINAL UNLESS ALL SIGNATURES COMPLETED

SEAL

NORTH CAROLINA PROFESSIONAL ENGINEER

SEAL 023489

PAMELA L. ALEXANDER

Signature: Pamela Alexander DATE: 6/7/2018

SIG. INVENTORY NO. B-9024

07-JUN-2018 11:15 D:\Projects\Traffic\Traffic\Task\00056469 U-6015 B-G Sig Sys\Task 05_11_Signal\Des\gn\B-9024.dgn ALEX3361 AT LUS340649

ECONOLITE ASC/3-2070 OVERLAP PROGRAMMING DETAIL

(program controller as shown)

1. From Main Menu select 2. CONTROLLER
2. From CONTROLLER Submenu select 2. VEHICLE OVERLAPS

OVERLAP B Toggle ONCE

Select TMG VEH OVLP [B] and 'OTHER/ECONOLITE'

TMG VEH OVLP... [B] TYPE: OTHER/ECONOLITE
PHASES 1 2 3 4 5 6 7 8 9 0 1 2 3 4 5 6
INCLUDED . . . X
PROTECT
PED PRTC
NOT OVLP
FLSH GRN . . . 1
LAG X PH
LAG 2 PH
LAG GRN 0.0 YEL 0.0 RED 0.0 ADV GRN 0.0

↓
OVERLAP D Toggle TWICE

Select TMG VEH OVLP [D] and 'PPLT FYA'

TMG VEH OVLP... [D] TYPE: PPLT FYA
PROTECTED LEFT TURN... PHASE 7
OPPOSING THROUGH..... PHASE 8
FLASHING ARROW OUTPUT.....CH12 ISOLATE
DELAY START OF: FYA..0.0 CLEARANCE..0.0
ACTION PLAN SF BIT DISABLE..... 0

END PROGRAMMING

FLASHER CIRCUIT MODIFICATION DETAIL

IN ORDER TO ENSURE THAT SIGNALS FLASH CONCURRENTLY ON THE SAME APPROACH, MAKE THE FOLLOWING FLASHER CIRCUIT CHANGES:

1. ON REAR OF PDA - REMOVE WIRE FROM TERM. T2-4 AND TERMINATE ON T2-2.
2. ON REAR OF PDA - REMOVE WIRE FROM TERM. T2-5 AND TERMINATE ON T2-3.
3. REMOVE FLASHER UNIT 2.

THE CHANGES LISTED ABOVE TIES ALL PHASES AND OVERLAPS TO FLASHER UNIT 1.

COUNTDOWN PEDESTRIAN SIGNAL OPERATION

Countdown Ped Signals are required to display timing only during Ped Clearance Interval. Consult Ped Signal Module user's manual for instructions on selecting this feature.

THIS ELECTRICAL DETAIL IS FOR
THE SIGNAL DESIGN: B-9024
DESIGNED: March 2018
SEALED: 6/7/2018
REVISED: N/A

Electrical Detail - Sheet 2 of 2

DOCUMENT NOT CONSIDERED
FINAL UNLESS ALL
SIGNATURES COMPLETED

ELECTRICAL AND PROGRAMMING
DETAILS FOR:

Prepared for the Offices of:

Boone Station Drive at Glidewell Drive/Tiki Lane	
Division 7	Alamance County Burlington
PLAN DATE: March 2018	REVIEWED BY: AM Encarnacion
PREPARED BY: NA Ptak	REVIEWED BY: PL Alexander
REVISIONS	INIT. DATE

Sealed by
Pamela Alexander 6/9/2018
DATE

SIG. INVENTORY NO. B-9024

09-JUN-2018 14:17
***SIGNALS.COM\PROJECTS\BURL\TransportationTraffic*Curr*00056469 U-6015 B-s Sig Sys*Task 05-11-15\Signal\00056469\WIF\Eng\9024E.dgn
ALEX3361 AT LUS20869

PHASING DIAGRAM

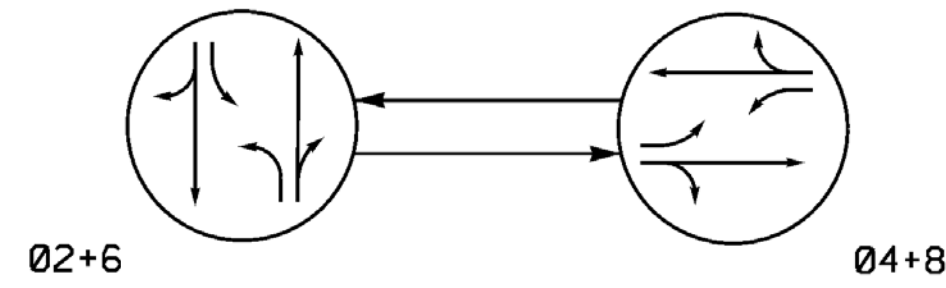

SIGNAL FACE	PHASE		
	02+6	04+8	FLASH
21, 22	G	R	Y
41, 42	R	G	R
61, 62	G	R	Y
81, 82	R	G	R

2 Phase
Pre-Timed
(Burlington-Graham Signal System)

PHASING DIAGRAM DETECTION LEGEND

- DETECTED MOVEMENT
- UNDETECTED MOVEMENT (OVERLAP)
- UNSIGNALIZED MOVEMENT
- ⚡ PEDESTRIAN MOVEMENT

SIGNAL FACE I.D.

All Heads L.E.D.

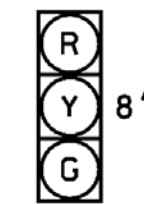

21, 22
41, 42
61, 62
81, 82

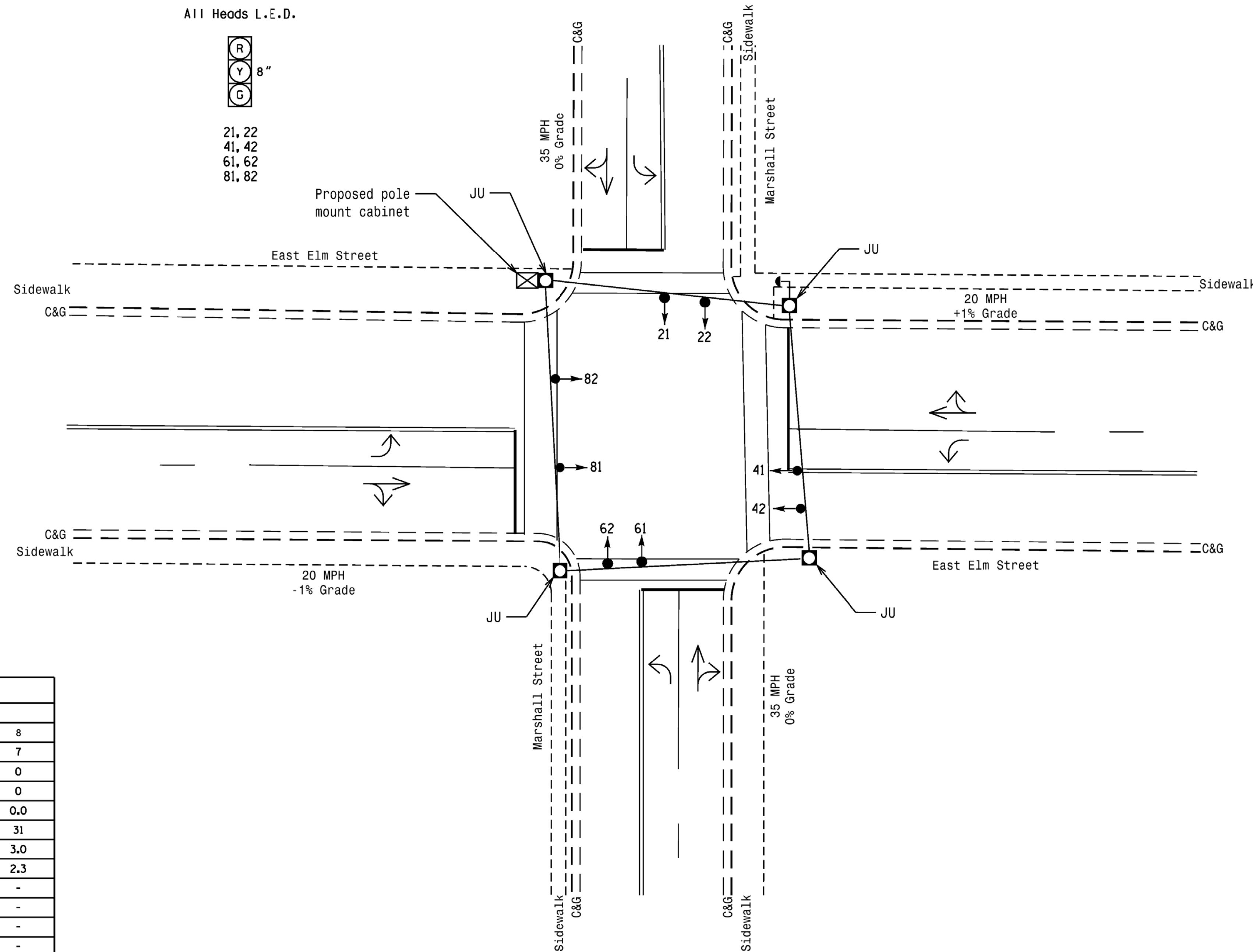

NOTES

- Refer to "Roadway Standard Drawings NCDOT" dated January 2018 and "Standard Specifications for Roads and Structures" dated January 2018.
- Do not program signal for late night flashing operation unless otherwise directed by the Engineer.
- Locate new cabinet so as not to obstruct sight distance of vehicles turning right on red.
- Pavement markings are existing.
- Maximum times shown in timing chart are for free-run operation only. Coordinated signal system timing values supersede these values.

FEATURE	ASC/3 TIMING CHART			
	2	4	6	8
Min Green *	10	7	10	7
Walk *	0	0	0	0
Ped Clear	0	0	0	0
Veh. Extension *	0.0	0.0	0.0	0.0
Max I *	39	31	39	31
Yellow	3.8	3.0	3.8	3.0
Red Clear	1.7	2.3	1.7	2.3
Actuations B4 Add *	-	-	-	-
Seconds / Actuation *	-	-	-	-
Max Initial *	-	-	-	-
Time Before Reduction *	-	-	-	-
Time To Reduce *	-	-	-	-
Minimum Gap	-	-	-	-
Locking Detector	-	-	-	-
Recall Position	MAX RECALL	MAX RECALL	MAX RECALL	MAX RECALL
Dual Entry	-	-	-	-
Simultaneous Gap	X	X	X	X

* These values may be field adjusted. Do not adjust Min Green and Extension times for phases 2 and 6 lower than what is shown. Min Green for all other phases should not be lower than 4 seconds.

PROPOSED	EXISTING
○ → Traffic Signal Head	● → N/A
○ → Modified Signal Head	○ → N/A
⊥ Sign	⊥ N/A
⊥ Pedestrian Signal Head With Push Button & Sign	⊥ N/A
○ Signal Pole with Guy	○ Signal Pole with Guy
○ Signal Pole with Sidewalk Guy	○ Signal Pole with Sidewalk Guy
□ Inductive Loop Detector	□ Inductive Loop Detector
⊗ Controller & Cabinet	⊗ Controller & Cabinet
□ Junction Box	□ Junction Box
--- 2-in Underground Conduit	--- 2-in Underground Conduit
N/A Right of Way	--- Right of Way
→ Directional Arrow	→ Directional Arrow

*****SYTIME*****
*****BUSRNAME*****



12 BROAD STREET
ASHEVILLE, NORTH CAROLINA 28801
(828) 254-2201
FAX (828) 254-4562
NC LIC. NO. C-1154

Signal Upgrade

Prepared for the Offices of:
TRANSPORTATION MOBILITY AND SAFETY DIVISION
NORTH CAROLINA DEPARTMENT OF TRANSPORTATION
Signal Design Section
750 N. Greenfield Pkwy, Garner, NC 27529
SCALE 1"=20'

DOCUMENT NOT CONSIDERED FINAL UNLESS ALL SIGNATURES COMPLETED

Marshall Street at East Elm Street

Division 7 Alamance County Graham

PLAN DATE: September 2017 REVIEWED BY: JB Voso

PREPARED BY: SE Wilson REVIEWED BY:

REVISIONS INIT. DATE

SEAL
NORTH CAROLINA PROFESSIONAL ENGINEER
JAMES B. VOSO
6/13/2018
SIG. INVENTORY NO. G-0100

**EDI MODEL 2018ECLip-NC CONFLICT MONITOR
PROGRAMMING DETAIL**

(remove jumpers and set switches as shown)

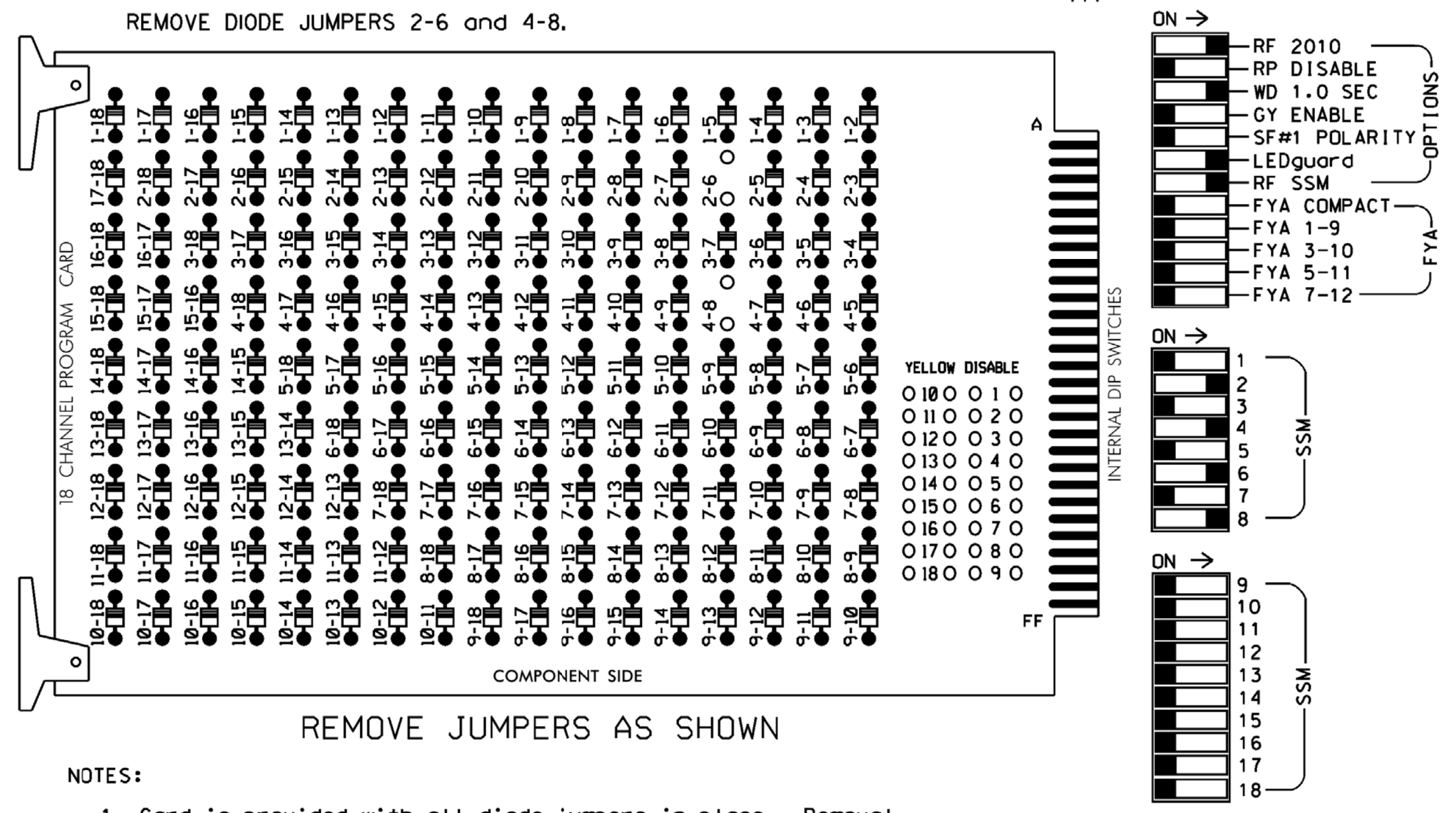

NOTES:

1. Card is provided with all diode jumpers in place. Removal of any jumper allows its channels to run concurrently.
2. Ensure jumpers SEL2-SEL5 and SEL9 are present on the monitor board.
3. Ensure that Red Enable is active at all times during normal operation.
4. Integrate monitor with Ethernet network in cabinet.

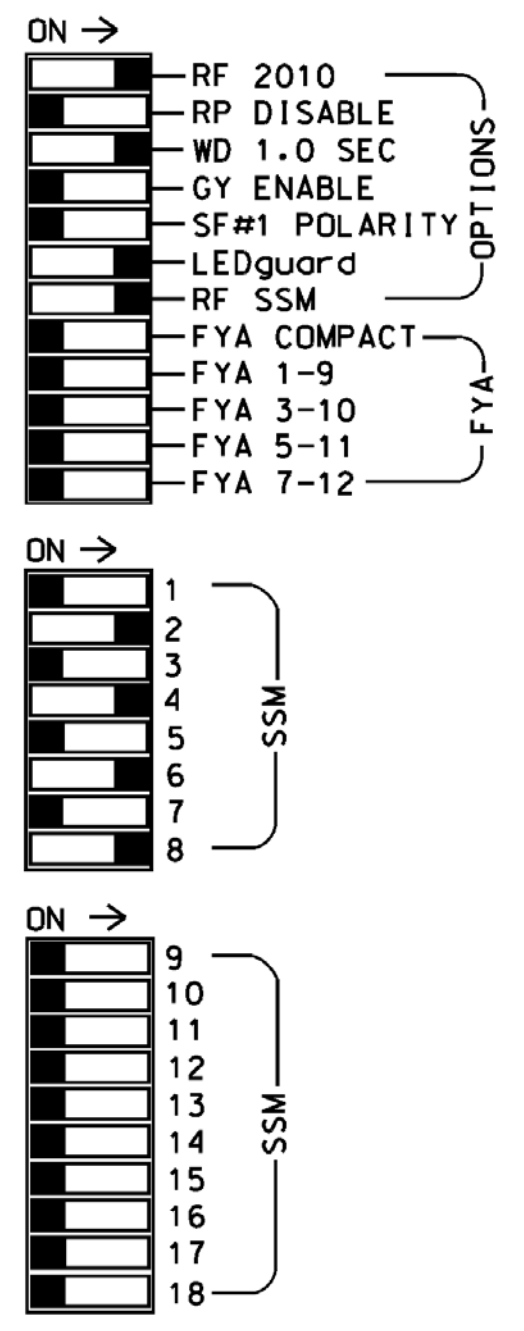
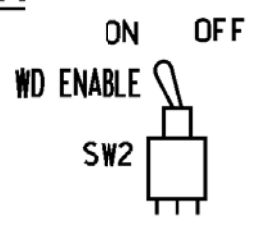

■ = DENOTES POSITION OF SWITCH

NOTES

1. To prevent "flash-conflict" problems, insert red flash program blocks for all unused vehicle load switches in the output file. The installer shall verify that signal heads flash in accordance with the Signal Plans.
2. Program controller to start up in phase 2 Green and 6 Green.
3. The cabinet and controller are part of the Burlington-Graham Signal System.

EQUIPMENT INFORMATION

CONTROLLER.....2070LX
 CABINET.....336
 SOFTWARE.....ECONOLITE ASC/3-2070
 CABINET MOUNT.....POLE
 OUTPUT FILE POSITIONS...12
 LOAD SWITCHES USED.....S2,S5,S8,S11
 PHASES USED.....2,4,6,8
 OVERLAPS.....NONE

SIGNAL HEAD HOOK-UP CHART

LOAD SWITCH NO.	S1	S2	S3	S4	S5	S6	S7	S8	S9	S10	S11	S12
CMU CHANNEL NO.	1	2	13	3	4	14	5	6	15	7	8	16
PHASE	1	2	2 PED	3	4	4 PED	5	6	6 PED	7	8	8 PED
SIGNAL HEAD NO.	NU	21,22	NU	NU	41,42	NU	NU	61,62	NU	NU	81,82	NU
RED		128			101			134			107	
YELLOW		129			102			135			108	
GREEN		130			103			136			109	
RED ARROW												
YELLOW ARROW												
GREEN ARROW												

NU = Not Used

INPUT FILE POSITION LAYOUT

(front view)

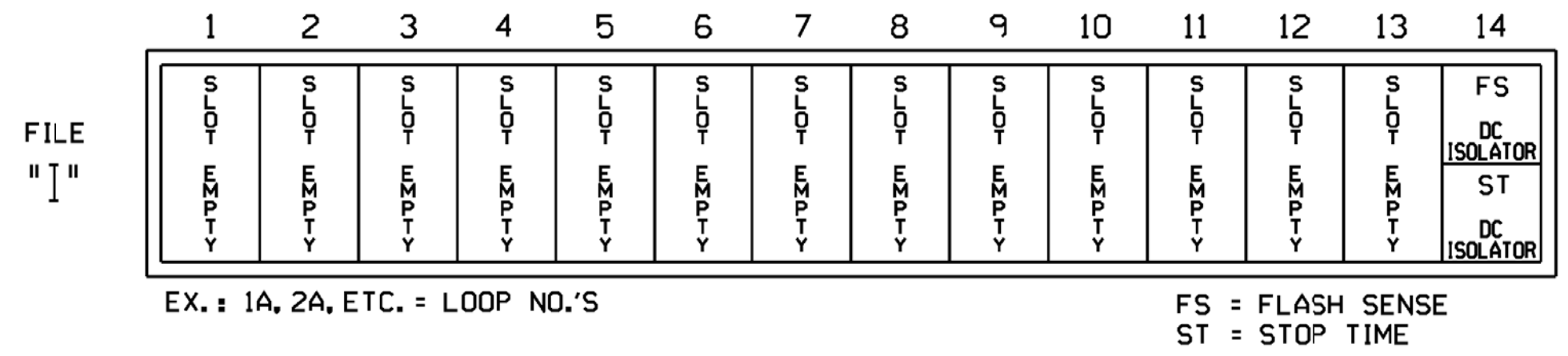

THIS ELECTRICAL DETAIL IS FOR THE SIGNAL DESIGN: G-0100
 DESIGNED: September 2017
 SEALED: 6/13/2018
 REVISED: NA

*****SYTIME*****
 *****D*****
 *****USER*****



12 BROAD STREET
 ASHEVILLE, NORTH CAROLINA 28801
 (828) 254-2201
 FAX (828) 254-4562
 NC LIC. NO. C-1154

Electrical Detail

DOCUMENT NOT CONSIDERED FINAL UNLESS ALL SIGNATURES COMPLETED

Marshall Street at East Elm Street

Division 7 Alamance County Graham

PLAN DATE: September 2017 REVIEWED BY: JB Voso

PREPARED BY: SE Wilson REVIEWED BY:

REVISIONS

INIT. DATE

James Voso 6/13/2018

SEAL NORTH CAROLINA PROFESSIONAL ENGINEER SEAL 022599 JAMES B. VOSO

SIG. INVENTORY NO. G-0100

PHASING DIAGRAM

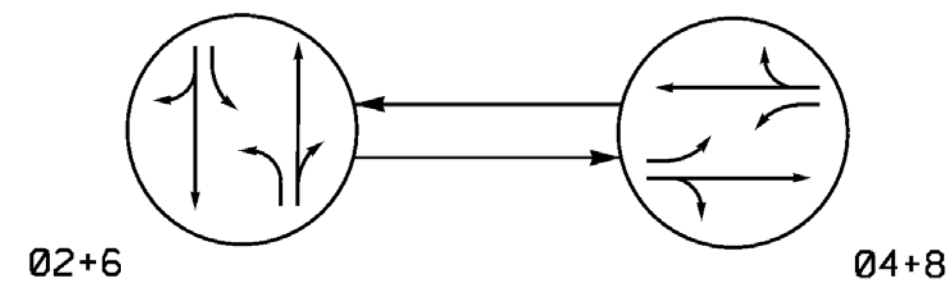

PHASING DIAGRAM DETECTION LEGEND

- DETECTED MOVEMENT
- UNDETECTED MOVEMENT (OVERLAP)
- UNSIGNALIZED MOVEMENT
- ⚡ PEDESTRIAN MOVEMENT

TABLE OF OPERATION

SIGNAL FACE	PHASE		
	02+6	04+8	FLASH
21, 22	G	R	Y
41, 42	R	G	R
61, 62	G	R	Y
81, 82	R	G	R

SIGNAL FACE I.D.

All Heads L.E.D.

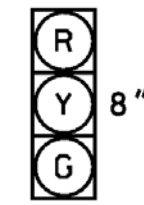

21, 22
41, 42
61, 62
81, 82

2 Phase
Pre-Timed
(Burlington-Graham Signal System)

NOTES

- Refer to "Roadway Standard Drawings NCDOT" dated January 2018 and "Standard Specifications for Roads and Structures" dated January 2018.
- Do not program signal for late night flashing operation unless otherwise directed by the Engineer.
- Locate new cabinet so as not to obstruct sight distance of vehicles turning right on red.
- Pavement markings are existing.
- Maximum times shown in timing chart are for free-run operation only. Coordinated signal system timing values supersede these values.

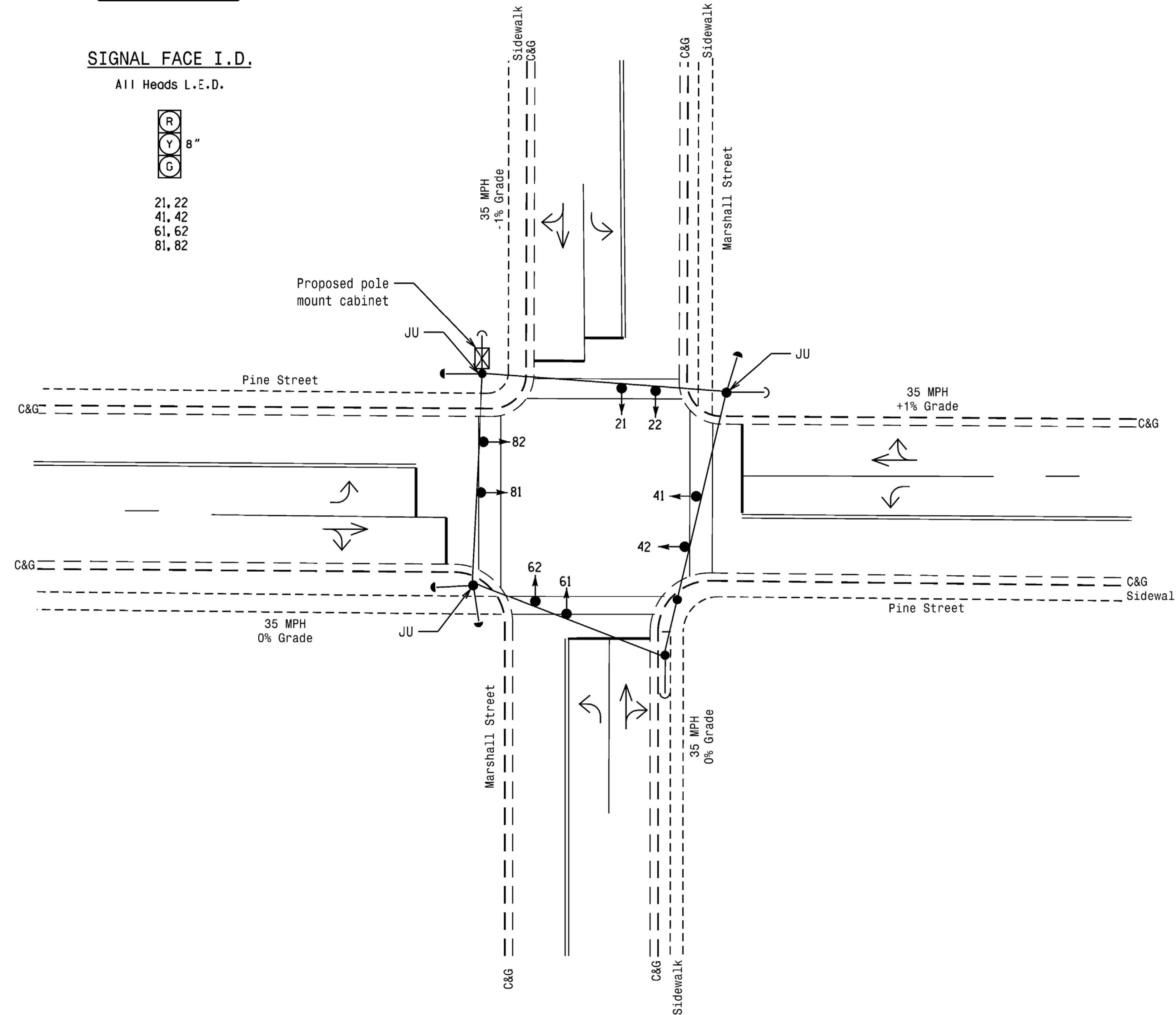

ASC/3 TIMING CHART

FEATURE	PHASE			
	2	4	6	8
Min Green *	10	7	10	7
Walk *	0	0	0	0
Ped Clear	0	0	0	0
Veh. Extension *	0.0	0.0	0.0	0.0
Max 1 *	31	38	31	38
Yellow	3.8	3.8	3.9	3.8
Red Clear	1.4	1.6	1.4	1.4
Actuations B4 Add *	-	-	-	-
Seconds / Actuation *	-	-	-	-
Max Initial *	-	-	-	-
Time Before Reduction *	-	-	-	-
Time To Reduce *	-	-	-	-
Minimum Gap	-	-	-	-
Locking Detector	-	-	-	-
Recall Position	MAX RECALL	MAX RECALL	MAX RECALL	MAX RECALL
Dual Entry	-	-	-	-
Simultaneous Gap	X	X	X	X

* These values may be field adjusted. Do not adjust Min Green and Extension times for phases 2 and 6 lower than what is shown. Min Green for all other phases should not be lower than 4 seconds.

LEGEND

- | | | | |
|--|---|--|--------------|
| | PROPOSED Traffic Signal Head | | EXISTING |
| | PROPOSED Modified Signal Head | | EXISTING N/A |
| | PROPOSED Sign | | EXISTING |
| | PROPOSED Pedestrian Signal Head With Push Button & Sign | | EXISTING |
| | PROPOSED Signal Pole with Guy | | EXISTING |
| | PROPOSED Signal Pole with Sidewalk Guy | | EXISTING |
| | PROPOSED Inductive Loop Detector | | EXISTING |
| | PROPOSED Controller & Cabinet | | EXISTING |
| | PROPOSED Junction Box | | EXISTING |
| | PROPOSED 2-in Underground Conduit | | EXISTING |
| | PROPOSED Right of Way | | EXISTING |
| | PROPOSED Directional Arrow | | EXISTING |

Mattern & Craig
ENGINEERS • SURVEYORS

12 BROAD STREET
ASHEVILLE, NORTH CAROLINA 28801
(828) 254-2201
FAX (828) 254-4562
NC LIC. NO. C-1154

Signal Upgrade

DOCUMENT NOT CONSIDERED FINAL UNLESS ALL SIGNATURES COMPLETED

	Marshall Street at Pine Street
	Division 7 Alamance County Graham
PLAN DATE: September 2017	REVIEWED BY: JB Voso
PREPARED BY: SE Wilson	REVIEWED BY:
REVISIONS	INIT. DATE
SCALE 1"=20'	DATE 6/13/2018
SIGNATURE	DATE
SIG. INVENTORY NO. C-0101	DATE

*****SYSTEM*****
*****USER*****