

# WATTLE DETAIL

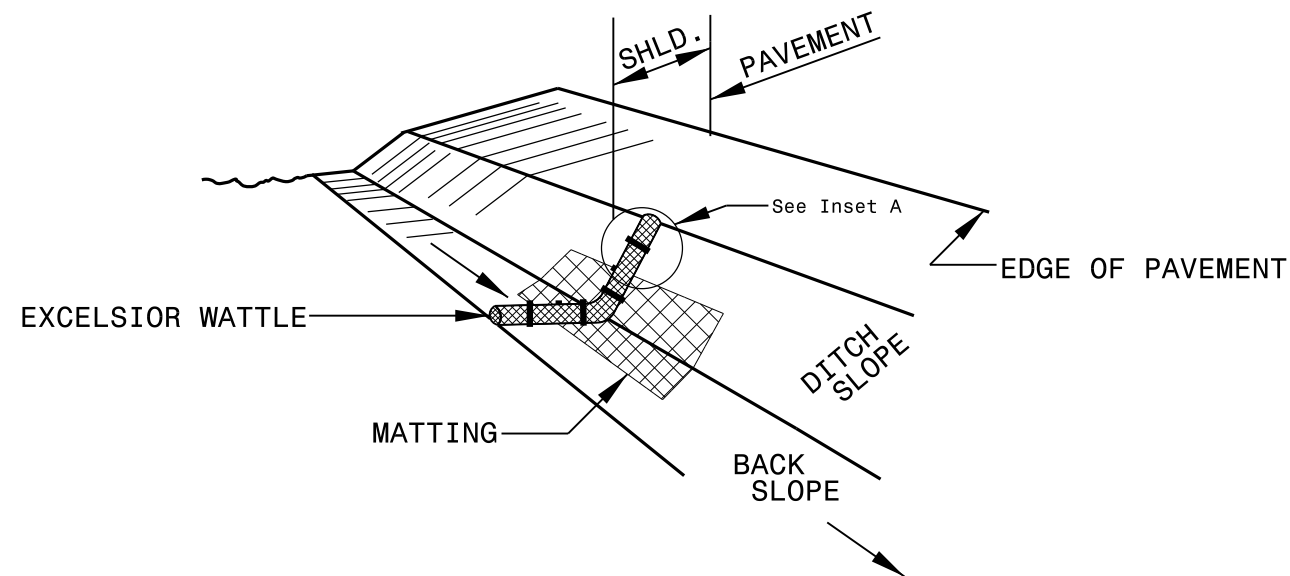

**ISOMETRIC VIEW**

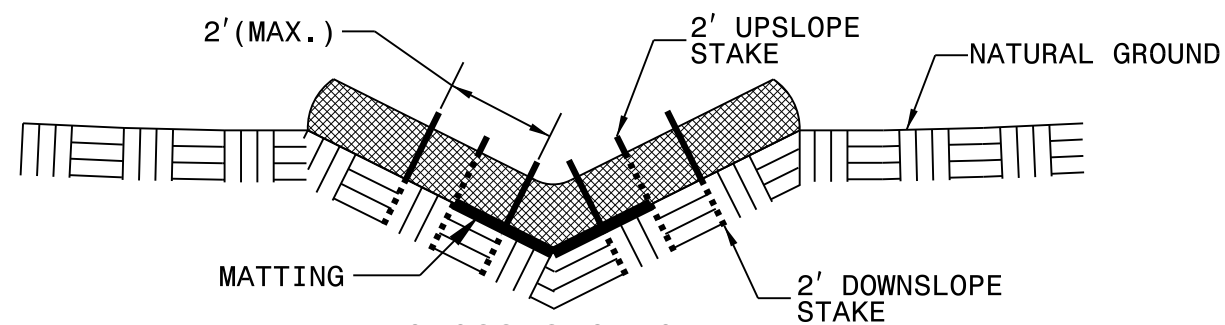

**CROSS SECTION  
VEE DITCH**

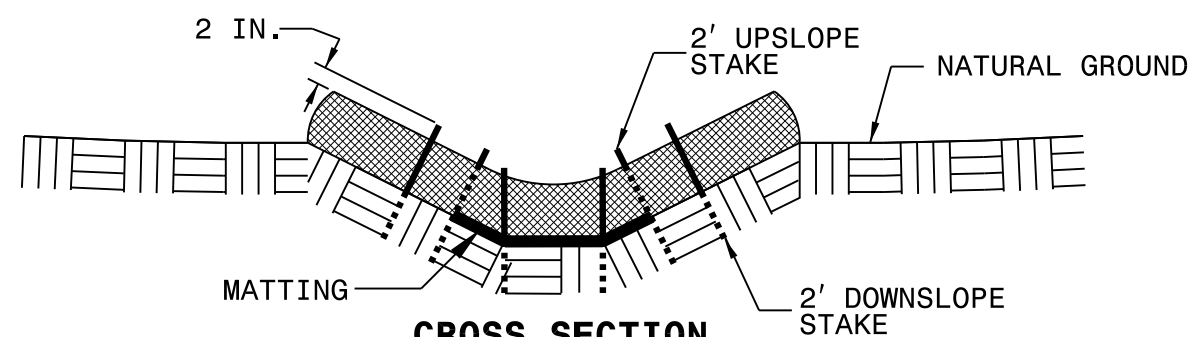

**CROSS SECTION  
TRAPEZOIDAL DITCH**

**NOTES:**

USE MINIMUM 12 IN. DIAMETER EXCELSIOR WATTLE.

USE 2 FT. WOODEN STAKES WITH A 2 IN. BY 2 IN. NOMINAL CROSS SECTION.

ONLY INSTALL WATTLE(S) TO A HEIGHT IN DITCH SO FLOW WILL NOT WASH AROUND WATTLE AND SCOUR DITCH SLOPES AND AS DIRECTED.

INSTALL A MINIMUM OF 2 UPSLOPE STAKES AND 4 DOWNSLOPE STAKES AT AN ANGLE TO WEDGE WATTLE TO BOTTOM OF DITCH.

PROVIDE STAPLES MADE OF 0.125 IN. DIAMETER STEEL WIRE FORMED INTO A U SHAPE NOT LESS THAN 12" IN LENGTH.

INSTALL STAPLES APPROXIMATELY EVERY 1 LINEAR FOOT ON BOTH SIDES OF WATTLE AND AT EACH END TO SECURE IT TO THE SOIL.

INSTALL MATTING IN ACCORDANCE WITH SECTION 1631 OF THE STANDARD SPECIFICATIONS.

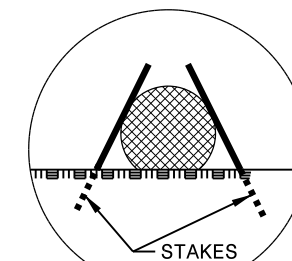

**INSET A**

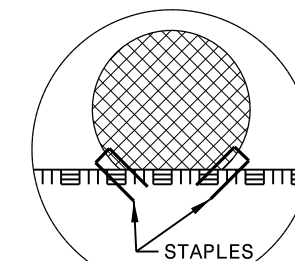

**INSET B**

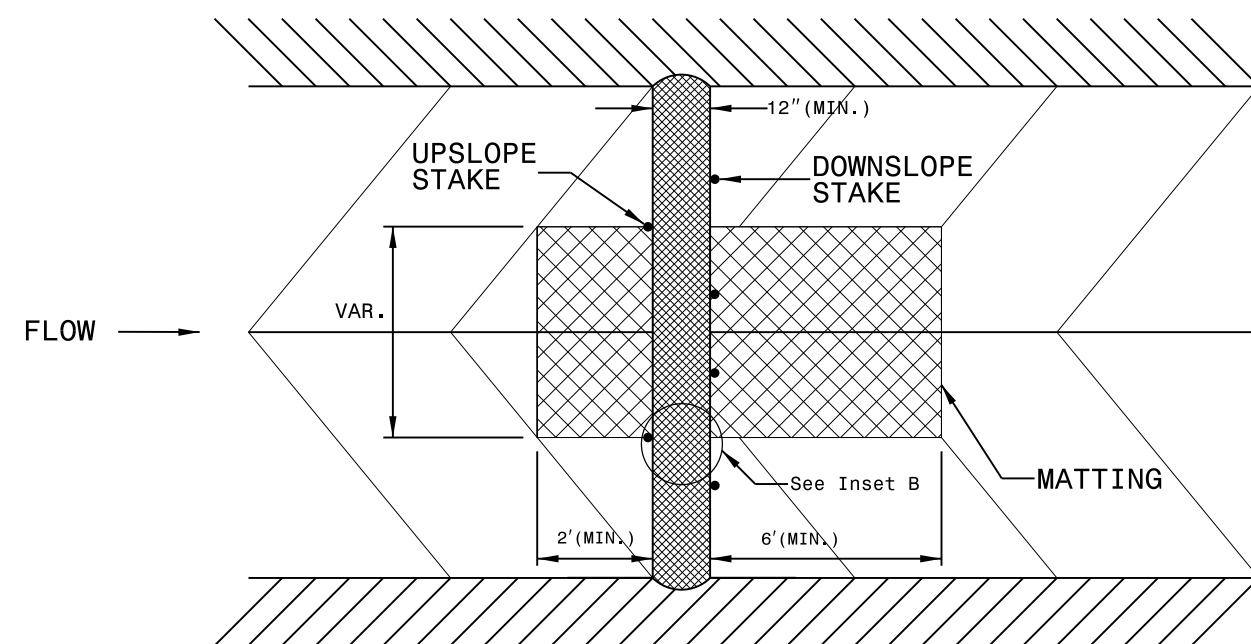

**TOP VIEW**

I:\FFB-2015\1141\01\Resurfacing\Plan\_Sheets\3CR.20711.173. EC RESURF. 2015.dgn  
 Date: 11/19/2015 11:41 AM  
 User: jfanning