

### EDI MODEL 2018EClip-NC CONFLICT MONITOR PROGRAMMING DETAIL

(remove jumpers and set switches as shown)

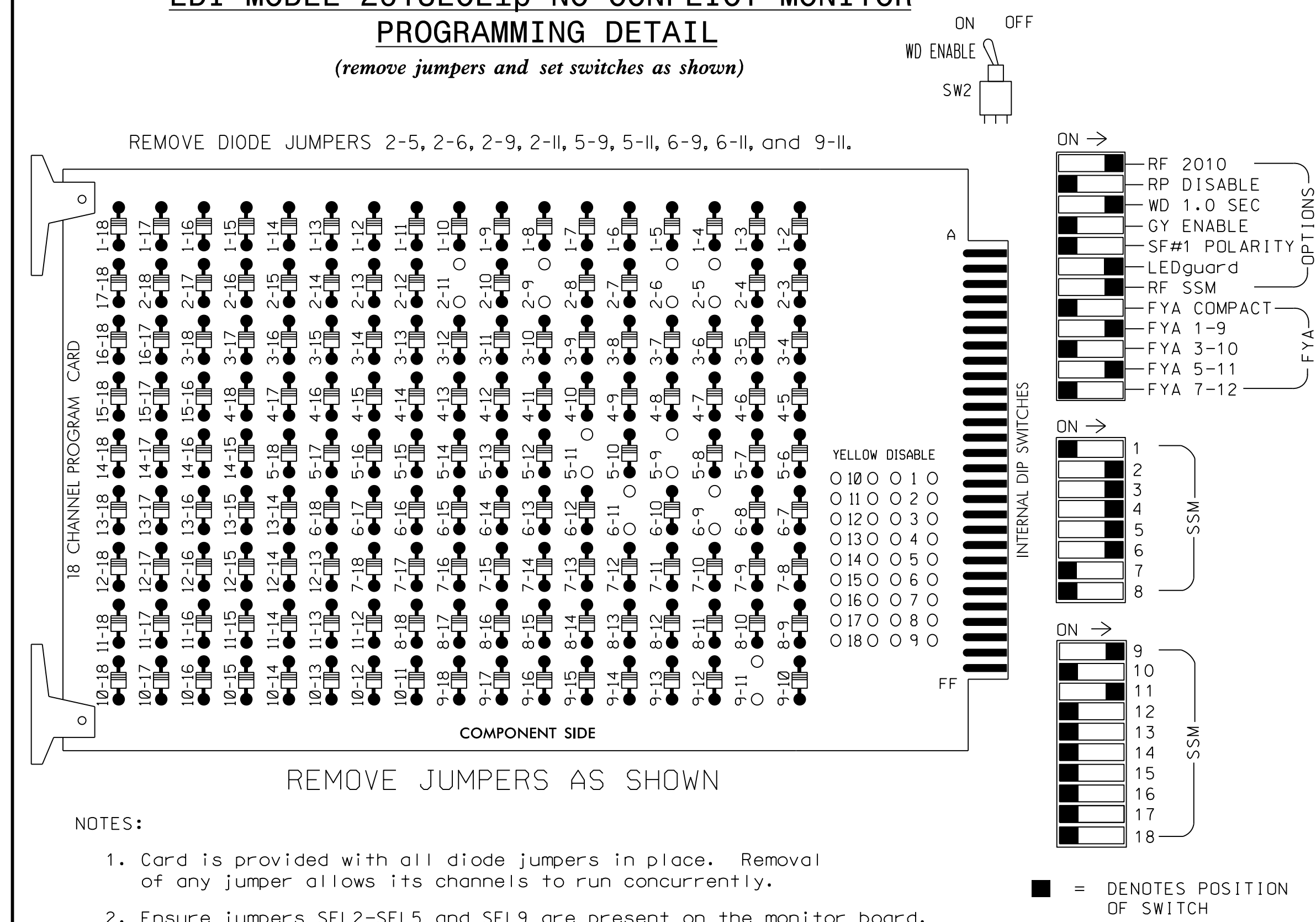

- ### NOTES
- To prevent "flash-conflict" problems, insert red flash program blocks for all unused vehicle load switches in the output file. The installer shall verify that signal heads flash in accordance with the Signal Plans.
  - Program controller to start up in phase 2 Green and 6 Green.
  - The cabinet and controller are part of the Fayetteville Signal System.

### EQUIPMENT INFORMATION

CONTROLLER.....2070  
 CABINET.....332 W/AUX  
 SOFTWARE.....ECONOLITE ASC/3-2070  
 CABINET MOUNT.....BASE  
 OUTPUT FILE POSITIONS...18 WITH AUX. OUTPUT FILE  
 LOAD SWITCHES USED.....S2,S4,S5,S7,S8,  
 AUX S1,AUX S4  
 PHASES USED.....2,3,4,5,6  
 OVERLAP "A".....\*  
 OVERLAP "B".....NOT USED  
 OVERLAP "C".....\*  
 OVERLAP "D".....NOT USED  
 \* See overlap programming detail on sheet 2

### SIGNAL HEAD HOOK-UP CHART

LOAD SWITCH NO.	S1	S2	S3	S4	S5	S6	S7	S8	S9	S10	S11	S12	AUX S1	AUX S2	AUX S3	AUX S4	AUX S5	AUX S6
CMU CHANNEL NO.	1	2	13	3	4	14	5	6	15	7	8	16	9	10	17	11	12	18
PHASE	1	2	2 PED	3	4	4 PED	5	6	6 PED	7	8	8 PED	OLA	OLB	SPARE	OLC	OLD	SPARE
SIGNAL HEAD NO.	NU	21,22	NU	31,32	33,34	41	42,43	NU	51	43	62,63	NU	61	NU	NU	51	NU	NU
RED		128		116	101	101		*		134								
YELLOW		129		117	102	102				135								
GREEN		130		118	103	103				136								
RED ARROW				116									A121			A114		
YELLOW ARROW				117					132				A122			A115		
FLASHING YELLOW ARROW													A123			A116		
GREEN ARROW				118	103		133	133										

NU = Not Used

\* Denotes install load resistor. See load resistor installation detail this sheet.

★ See pictorial of head wiring in detail this sheet.

### DETECTOR NOTES

- For all loops, install a video detection system for vehicle detection. Perform installation according to manufacturer's directions and NCDOT engineer-approved mounting locations to accomplish the detection schemes shown on the Signal Design Plans.
- For loop 5A, detector card placement and slot reserved for wired inputs are typical for a NCDOT installation. Inputs associated with this slot are compatible with time of day instructions located on sheet 2 of this electrical detail.

### INPUT FILE POSITION LAYOUT

(front view)

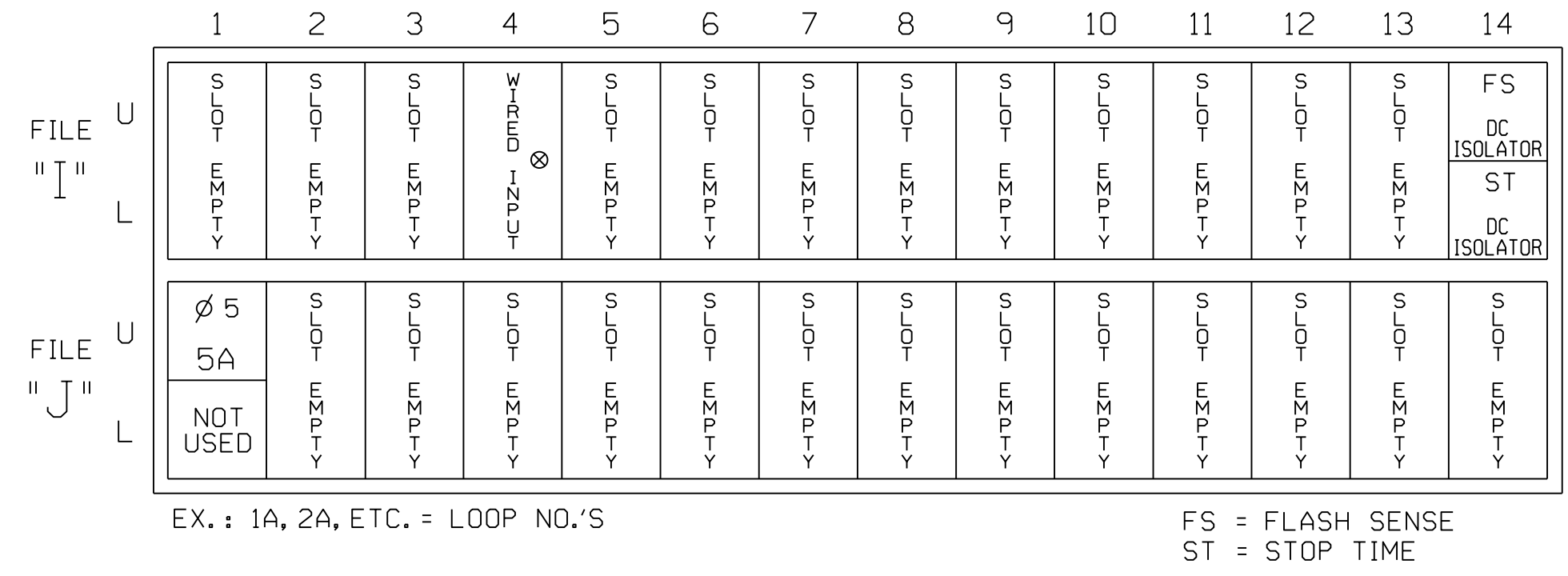

### FYA SIGNAL WIRING DETAIL

(wire signal heads as shown)

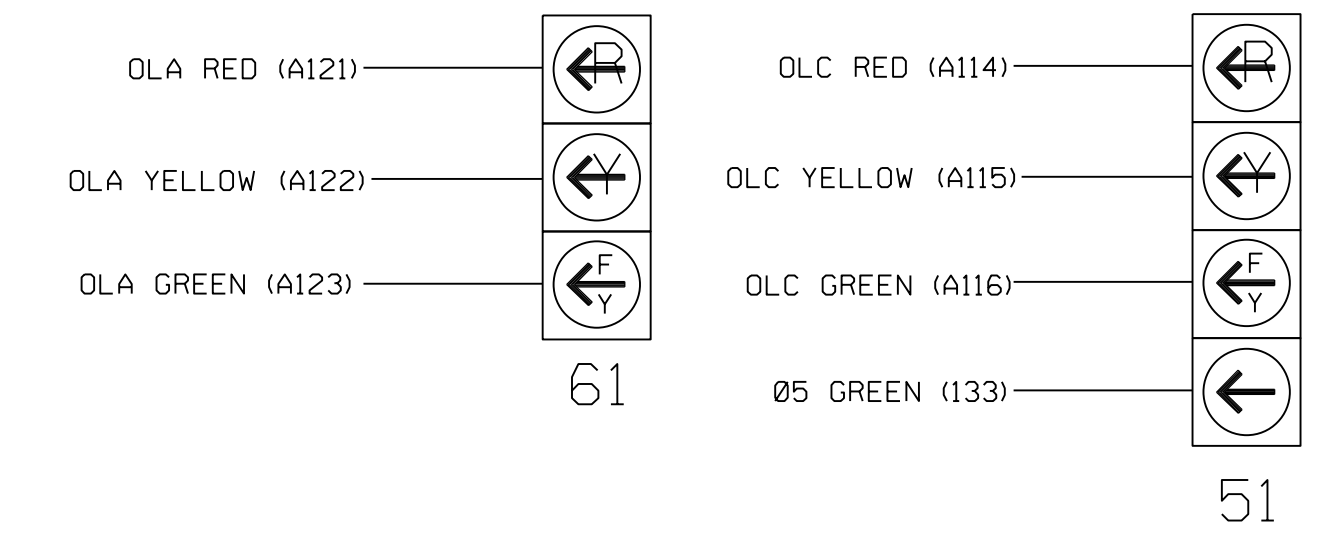

### LOAD RESISTOR INSTALLATION DETAIL

(install resistor as shown)

VALUE (ohms)	WATTAGE
1.5K - 1.9K	25W (min)
2.0K - 3.0K	10W (min)

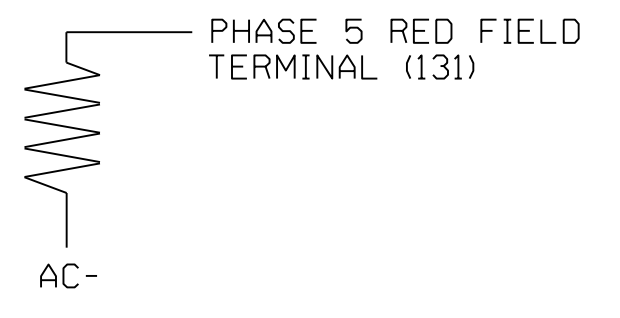

### INPUT FILE CONNECTION & PROGRAMMING CHART

LOOP NO.	LOOP TERMINAL	INPUT FILE POS.	PIN NO.	DETECTOR NO.	NEMA PHASE	CALL	EXTEND TIME	DELAY TIME	ADDED INITIAL	DETECTOR TYPE
5A <sup>1</sup>	-	J1U	58	5 ★	5	YES		15		S
	-	14U	47	22 ★	2	YES				S

<sup>1</sup>Add jumper from J1-W to 14-W, on rear of input file.

★ See vehicle detector setup programming detail for alternate phasing on sheet 2.

INPUT FILE POSITION LEGEND: J2L

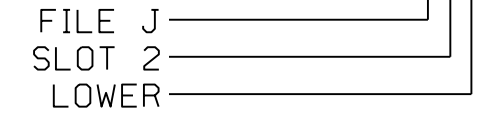

THIS ELECTRICAL DETAIL IS FOR THE SIGNAL DESIGN: 06-0002T1  
 DESIGNED: March 2018  
 SEALED: 03-29-2018  
 REVISED: N/A

Temporary Design 1 - TMP Phase I  
 Electrical Detail - Sheet 1 of 2

Stantec Consulting Services Inc.  
 801 Jones Franklin Road-Suite 300  
 Raleigh, NC 27606  
 Tel. (919) 851-6866  
 Fax. (919) 851-7024  
 www.stantec.com  
 License No. F-0672

Lawrence E. Overn  
 Professional Engineer  
 License No. 045933

ELECTRICAL AND PROGRAMMING DETAILS FOR:		US 401 Bus./SR 1414 (Raeford Road)	
Prepared in the Offices of:		at	
US 401 Bus. (Robeson Street)		/McPhee Drive	
Division 6	Cumberland County	Fayetteville	
PLAN DATE: March 2018	REVIEWED BY: L Overn		
PREPARED BY: G B Spell	REVIEWED BY:		
REVISIONS	INIT.	DATE	

SEAL

06-0002T1

3/29/2018

DATE

SIG. INVENTORY NO. 06-0002T1