

RAILROAD PREEMPTION WIRING DETAIL FOR RR2 (LINKED RR PREEMPTS 3 & 4)

(wire as shown below)

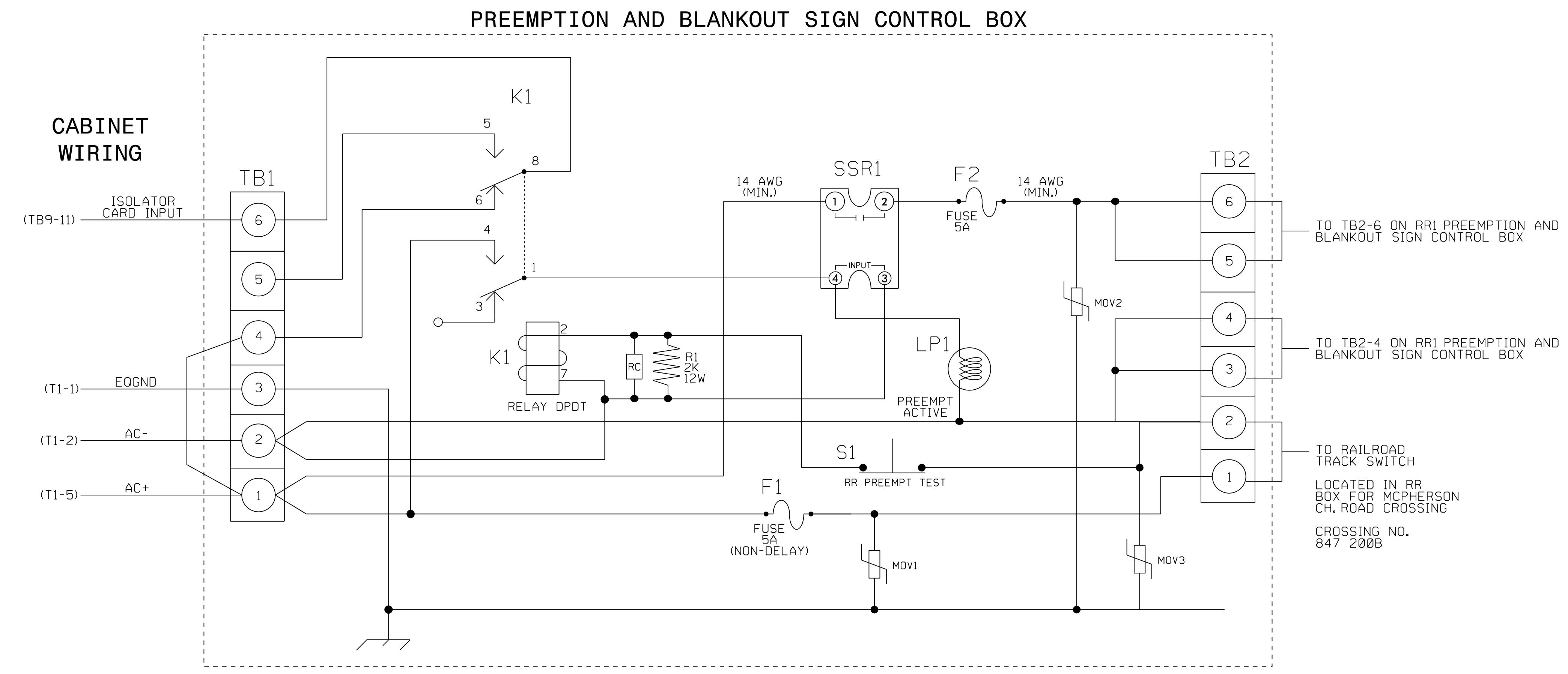

NOTES

1. Relay K1 is shown in the energized (Preempt not active) normal operation state.
2. Relay K1 is a DPDT with 120VAC coil with octabase.
3. Relay SSR1 is a SPST (normally open) Solid State Relay with AC input and AC (25 amp) output.
4. AC Isolator Card shall activate preemption upon removal of AC+ from the input (as shown above). To accomplish this set invert dip switch on AC Isolator Card. See AC Isolator Output Programming Detail on Sheet 1.

FRONT VIEW

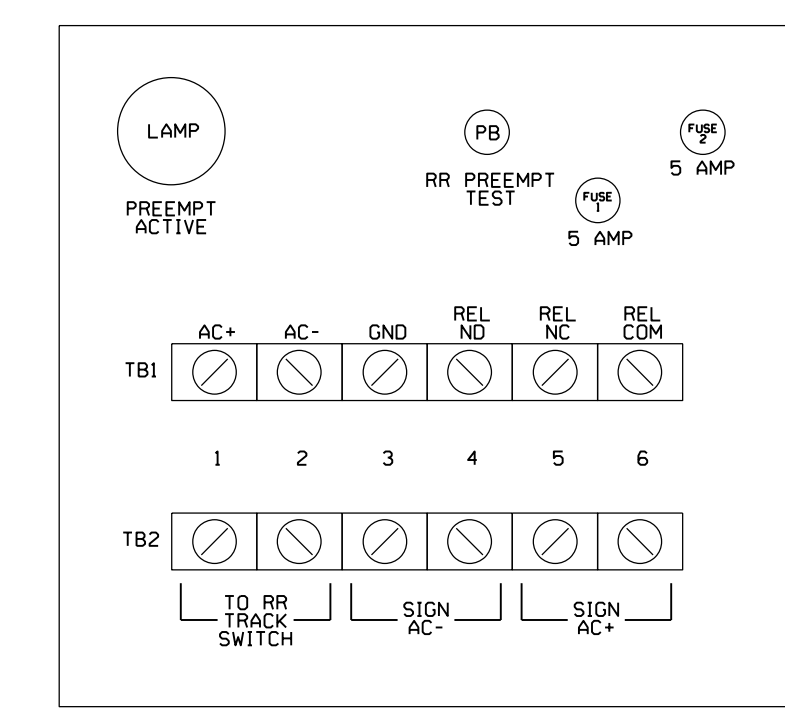

THIS ELECTRICAL DETAIL IS FOR THE SIGNAL DESIGN: 06-005472
DESIGNED: March 2018
SEALED: 03-29-2018
REVISED: N/A

Temporary Design 2 - TMP Phase II
Electrical Detail - Sheet 3 of 5

Stantec Consulting Services Inc.
801 Jones Franklin Road-Suite 300
Raleigh, NC 27606
Tel. (919) 851-6866
Fax. (919) 851-7024
www.stantec.com
License No. F-0672

Prepared in the Offices of:

750 N. Greenfield Pkwy, Garner, NC 27529

US 401 Business (Raeford Road)
at
McPherson Church Road/
Owen Drive
Division 6 Cumberland County Fayetteville

PLAN DATE: March 2018	REVIEWED BY: L Overn
PREPARED BY: G B Spell	REVIEWED BY:
REVISIONS	INIT. DATE

SEAL
NORTH CAROLINA
PROFESSIONAL
ENGINEER
LAWRENCE E. OVERN
045933
3/29/2018
DATE
SIG. INVENTORY NO. 06-005472

DATE: 03/29/2018 10:45:12 AM User: rfmancey