

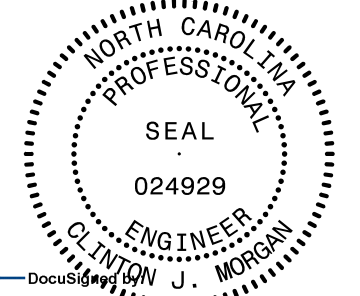

8/17/19

PROJECT REFERENCE NO. U-4405		SHEET NO. 6	
ROADWAY DESIGN ENGINEER		HYDRAULICS ENGINEER	
			
Date: 3/13/2018 Location: Morganton, NC		Date: 3/13/2018 Location: Morganton, NC	
DOCUMENT NOT CONSIDERED FINAL UNLESS ALL SIGNATURES COMPLETED			

NOTE: COORDINATION WITH RESIDENT ENGINEER IS REQUIRED PRIOR TO ANY TREE REMOVAL ON PARCEL 55

MATCHLINE SEE SHEET 28  
-SR3- STA 13+50

MATCHLINE SEE SHEET 28  
-Y4- STA 16+50

MATCHLINE SEE SHEET 5  
-L- STA 35+50

MATCHLINE SEE SHEET 7  
-L- STA 48+00

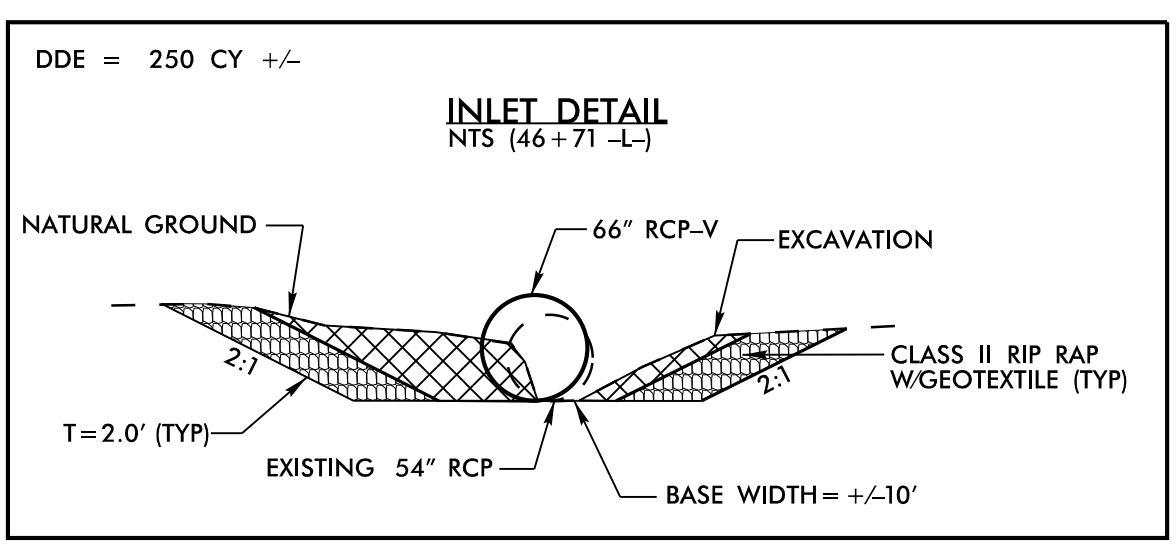
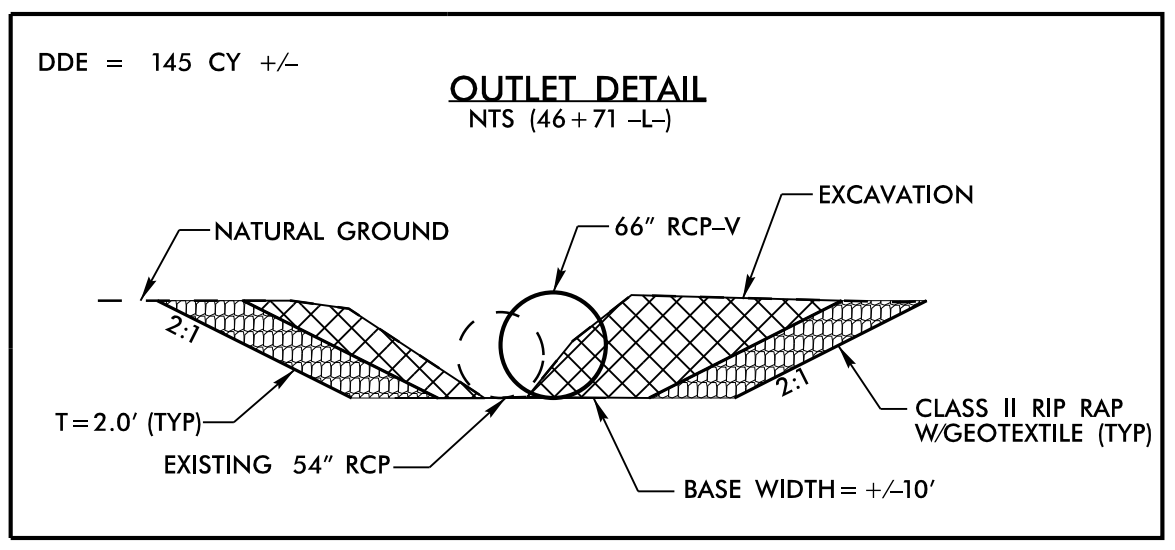
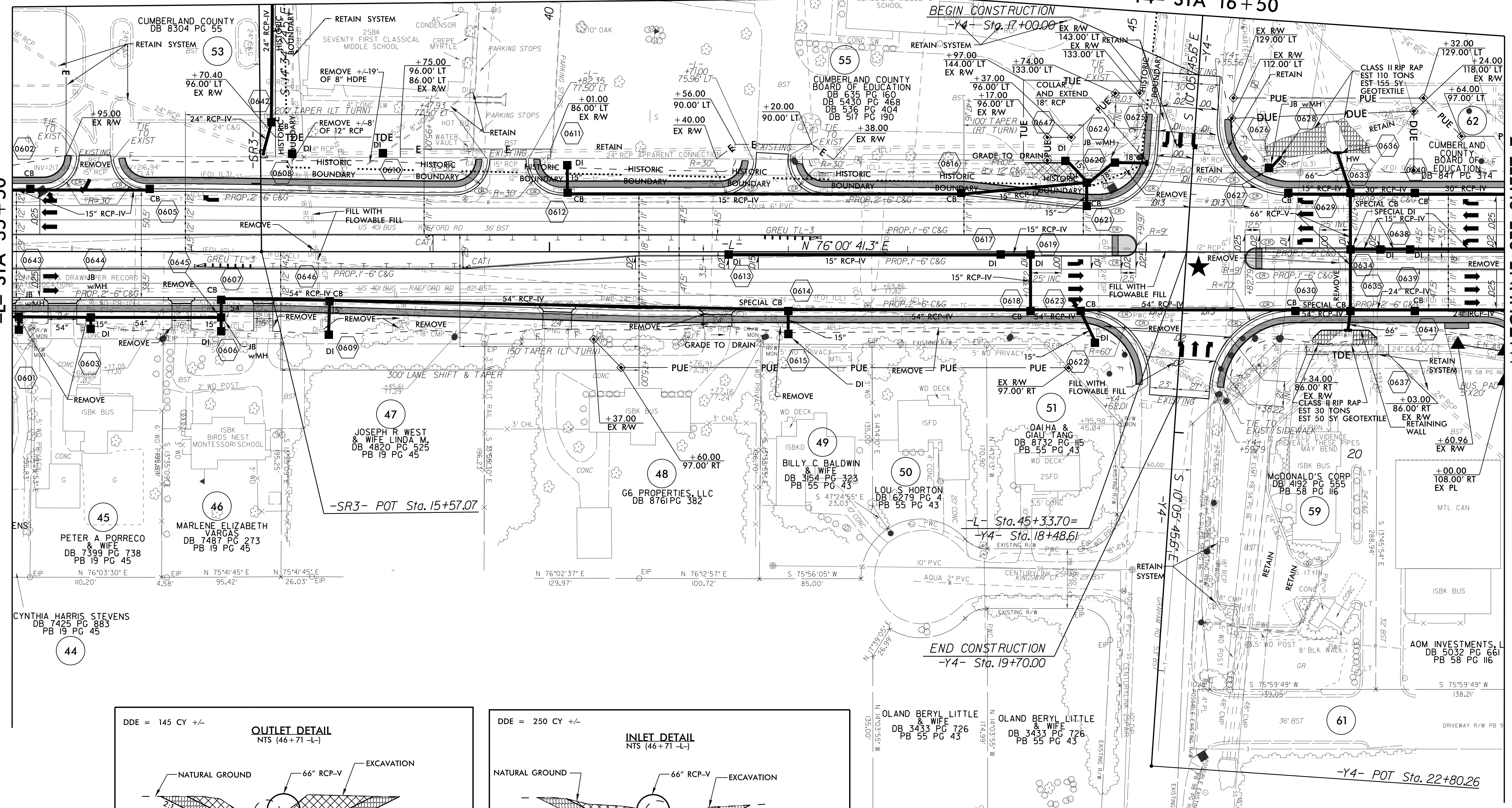

NOTE: BUS PADS WILL BE PAID FOR AS SIDEWALK  
SEE SHEET 33 & 34 FOR -L- PROFILE  
SEE SHEET 46 FOR -Y4- PROFILE  
SEE SHEET C1-1 THRU C1-18 FOR CULVERT PLANS

★ PROPOSED SIGNAL

▬ PROP CONC SIDEWALK

07-JUL-2018 12:22  
 R2:\Projects\4405\rdw\_psh\_06.dgn  
 8:58 AM