

**This electronic collection of documents is provided
for the convenience of the user
and is Not a Certified Document –**

**The documents contained herein were originally issued
and sealed by the individuals whose names and license
numbers appear on each page, on the dates appearing
with their signature on that page.**

**This file or an individual page
shall not be considered a certified document.**

**STATE OF NORTH CAROLINA
DEPARTMENT OF TRANSPORTATION**

**SIGNING PLAN
WAKE & FRANKLIN COUNTY**

LOCATION: US 401 FROM NC 96 TO NORTH OF SR 1103 (FLAT ROCK CHURCH RD/CLIFTON POND RD)

T.I.P.: R-2814C

CONTRACT: C204105

ROADWAY STANDARD DRAWING

THE FOLLOWING ROADWAY STANDARDS AS APPEAR IN "ROADWAY STANDARD DRAWINGS" - PROJECT SERVICES UNIT - N.C. DEPARTMENT OF TRANSPORTATION - RALEIGH, N.C., DATED JANUARY 2018 ARE APPLICABLE TO THIS PROJECT AND BY REFERENCE HEREBY ARE CONSIDERED A PART OF THESE PLANS:

STD. NO.	TITLE
901.50	ARROWS AND SHIELDS
903.10	GROUND MOUNTED SIGN SUPPORTS
904.10	ORIENTATION OF GROUND MOUNTED SIGNS
904.50	MOUNTING OF TYPE 'D', 'E' AND 'F' SIGNS ON 'U' CHANNEL POSTS
910.30	SIGNING SIGNALIZED AND UNSIGNALIZED SUPERSTREET

GENERAL NOTES

- . SIGNS FURNISHED BY STATE
- . CONFIRM IN WRITING AT LEAST 4 MONTHS IN ADVANCE, THE ACTUAL DATE THE DEPARTMENT FURNISHED SIGNS WILL BE REQUIRED.
- . ALL TYPE 'D' SIGNS SHALL BE MOUNTED ON TWO U-CHANNEL POSTS UNLESS OTHERWISE INDICATED ON THE PLANS.
- . IF REMOVAL OR RELOCATION OF SIGNS ON PRIVATE STREET (NON-STATE MAINTAINED) IS REQUIRED DUE TO CONSTRUCTION, THE CONTRACTOR SHALL INFORM THE ENGINEER. THE WORK WILL BE COMPLETED BY OTHERS.
- . WHEN NOT STATIONED OR DIMENSIONED ON PLANS, ALL 'E' AND 'F' SIGNS SHALL BE FIELD LOCATED BY THE ENGINEER
- . ALL EXISTING SIGNS ON "U" CHANNEL POST WITHIN THE PROJECT LIMITS SHALL BE REMOVED AND DISPOSED OF UNLESS OTHERWISE NOTED ON PLANS.
- . WHEN EXISTING SIGNS ARE REMOVED AND INSTALLED ON NEW SUPPORTS, THE RE-ERECTION SHALL IMMEDIATELY FOLLOW THE REMOVAL.
- . THE BACKGROUND FOR TYPE E & F SIGNS SHALL BE TYPE C REFLECTIVE SHEETING.
- . DO NOT BEGIN FABRICATION FOR TYPES A & B SIGNS MOUNTED ON OVERHEAD STRUCTURES OR STEEL SUPPORTS UNTIL "S" DIMENSIONS HAVE BEEN FIELD VERIFIED.
- . SEE ROADWAY PLANS FOR GUARD/GUIDE RAIL DETAILS.

SUMMARY OF QUANTITIES

ITEM NO.		ITEM DESCRIPTION	QUANTITY	UNIT
DESC. NO.	SECT. NO.			
4072000000	903	SUPPORTS, 3 LB STEEL U-CHANNEL	4300	L.F.
4096000000	904	SIGN ERECTION, TYPE D	9	EA.
4102000000	904	SIGN ERECTION, TYPE E	165	EA.
4108000000	904	SIGN ERECTION, TYPE F	52	EA.
4116100000	904	SIGN ERECTION, RELOCATE SIGN TYPE E	10	EA.
4155000000	907	DISPOSAL OF SIGN SYSTEM, U-CHANNEL	66	EA.
4192000000	907	DISPOSAL OF SUPPORT, U-CHANNEL	10	EA.

INDEX

SHEET NO.	DESCRIPTION
SIGN-1	TITLE SHEET
SIGN-2 & 2A	E AND F SHEETS
SIGN-3-3B	SIGN DESIGNS
SIGN-4-23	SIGNING PLAN SHEETS

PLAN PREPARED BY: N.C.D.O.T. SIGNING AND DELINEATION UNIT

AYMAN ALQUDWAH, P.E. SIGNING & DELINEATION REGIONAL ENGINEER

STACEY JOHNS SIGNING & DELINEATION PROJECT DESIGN ENGINEER

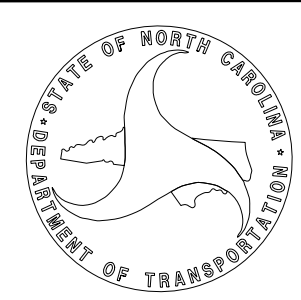

APPROVED: *Asman Alqudwah*
Professional Engineer - License No. 13243
 DATE: 4/24/2018

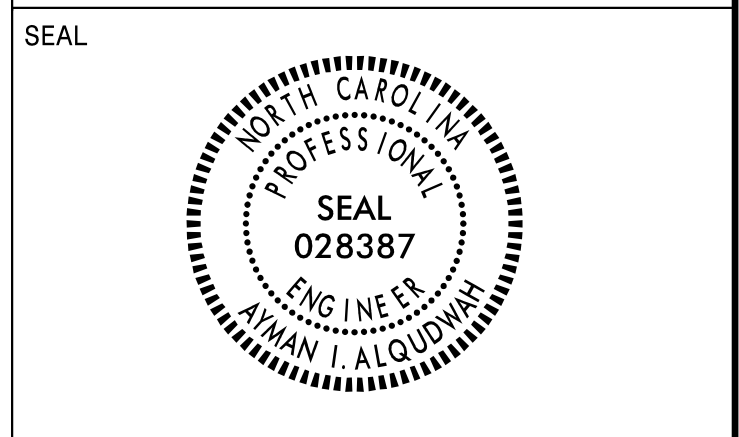

**DOCUMENT NOT CONSIDERED FINAL
 UNLESS ALL SIGNATURES COMPLETED**

401 QUANTITY REQ'D 16



MOUNT BACK TO BACK WITH SIGN 414
 IN 1 INSTALLATIONS
 TWO "U" POSTS PER SIGN

406 QUANTITY REQ'D 1

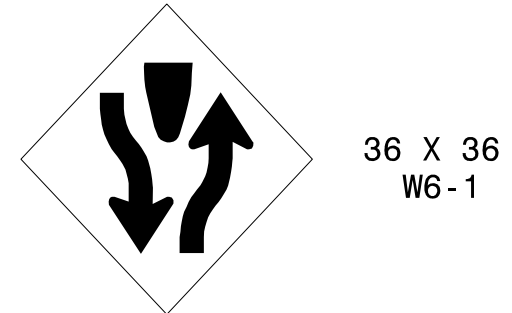

ONE "U" POST PER SIGN

411 QUANTITY REQ'D 20

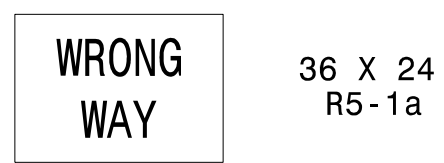

ONE "U" POST PER SIGN

402 QUANTITY REQ'D 27

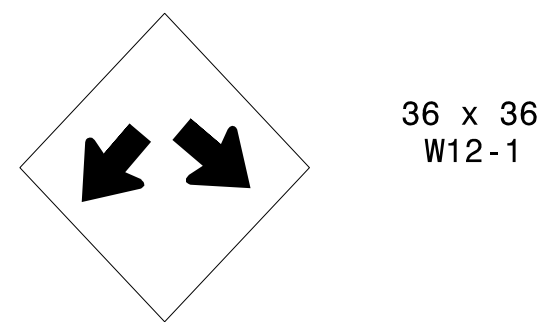

ONE "U" POSTS PER SIGN

407 QUANTITY REQ'D 17



MOUNT ABOVE SIGN 405
 IN 17 INSTALLATIONS
 TWO "U" POSTS PER SIGN

412 QUANTITY REQ'D 2



TWO "U" POSTS PER SIGN

403 QUANTITY REQ'D 12



ONE "U" POST PER SIGN

408 QUANTITY REQ'D 8

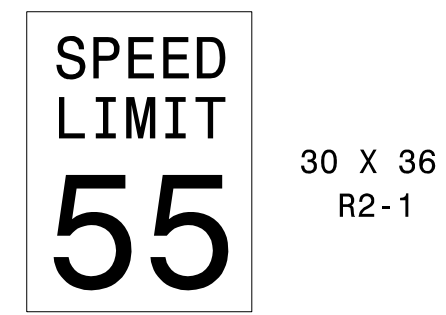

ONE "U" POST PER SIGN

413 QUANTITY REQ'D 2

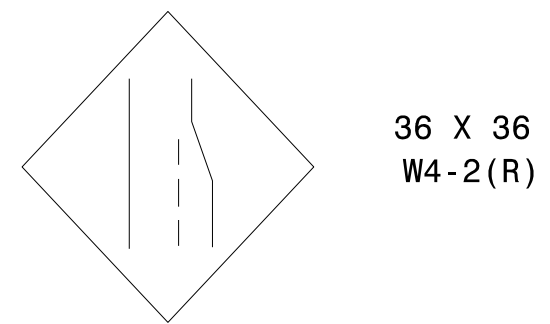

TWO "U" POSTS PER SIGN

404 QUANTITY REQ'D 10

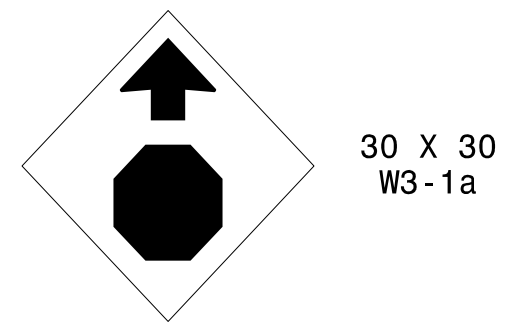

ONE "U" POST PER SIGN

409 QUANTITY REQ'D 10

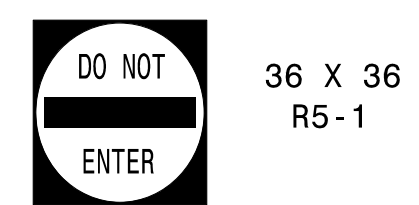

ONE "U" POST PER SIGN

414 QUANTITY REQ'D 1

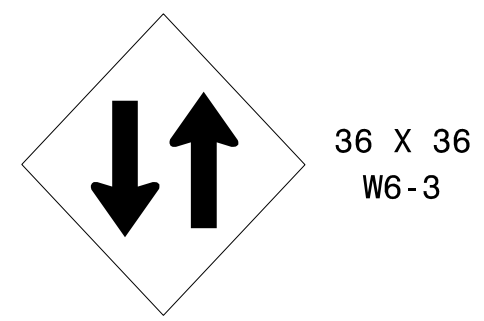

ONE "U" POST PER SIGN

405 QUANTITY REQ'D 17



ONE "U" POST PER SIGN

410 QUANTITY REQ'D 22



ONE "U" POST PER SIGN

TYPE "E" SIGNS

APPROVED: *Asman Alqudwah*
Professional Engineer
 DATE: 4/24/2018

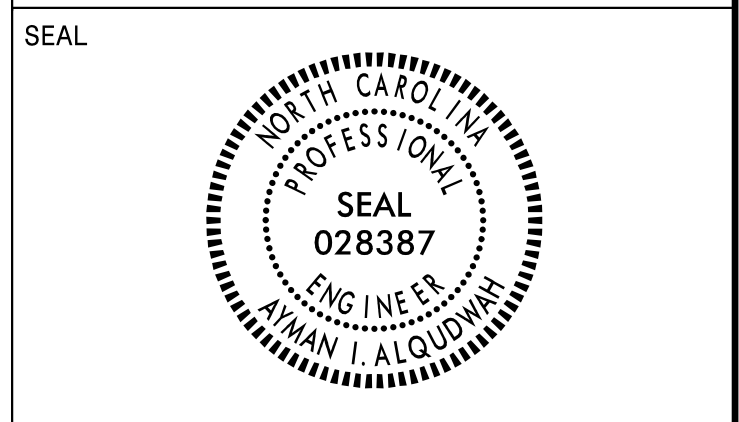

**DOCUMENT NOT CONSIDERED FINAL
 UNLESS ALL SIGNATURES COMPLETED**

501

2 - 24 X 12
 2 - 24 X 24
 2 - 21 X 15

MOUNTED BELOW SIGN 301

506

1 - 24 X 12
 1 - 24 X 24

ONE "U" POST PER SIGN

512 520 536 539 543 547

1 - 24 X 12
 1 - 30 X 24
 1 - 24 X 24

ONE "U" POST PER SIGN

527

1 - 24 X 12
 1 - 24 X 24

ONE "U" POST PER SIGN

502 511 523 535 538 541 546 552

1 - 24 X 12
 1 - 30 X 24

ONE "U" POST PER SIGN

507 515 519 528 534 550

1 - 24 X 12
 2 - 24 X 12
 2 - 30 X 24
 2 - 21 X 15

TWO "U" POSTS PER SIGN

514 518 533 540 544 549

1 - 24 X 12
 1 - 30 X 24
 1 - 24 X 24

ONE "U" POST PER SIGN

529

1 - 24 X 12
 2 - 24 X 12
 1 - 30 X 24
 1 - 24 X 24
 2 - 24 X 24

TWO "U" POSTS PER SIGN

503

1 - 24 X 12
 1 - 24 X 24

ONE "U" POST PER SIGN

508

1 - 24 X 12
 2 - 24 X 12
 1 - 30 X 24
 1 - 24 X 24
 2 - 24 X 24

TWO "U" POSTS PER SIGN

522

2 - 24 X 12
 2 - 24 X 24
 2 - 21 X 15

MOUNTED BELOW SIGN 306

531

2 - 24 X 12
 2 - 24 X 24
 2 - 21 X 15

MOUNTED BELOW SIGN 307

504 513 517 525 532 548

1 - 24 X 12
 2 - 24 X 12
 2 - 30 X 24
 2 - 21 X 15

TWO "U" POST PER SIGN

509

2 - 24 X 12
 2 - 24 X 24
 2 - 21 X 15

MOUNTED BELOW SIGN 302

524

1 - 24 X 12
 1 - 24 X 24

ONE "U" POST PER SIGN

505

1 - 24 X 12
 2 - 24 X 12
 1 - 30 X 24
 1 - 24 X 24
 2 - 24 X 24

TWO "U" POSTS PER SIGN

510 516 521 530 537 542 545 551

1 - 24 X 12
 1 - 30 X 24

ONE "U" POST PER SIGN

526

1 - 24 X 12
 2 - 24 X 12
 1 - 30 X 24
 1 - 24 X 24
 2 - 24 X 24

TWO "U" POSTS PER SIGN

TYPE "F" SIGNS

04/24/18
 N:\Projects-R\2814c\Traffic\Signing\CADD\Signing\Layout\Plans\2814C_Signs_1.dgn
 Insert:johns

APPROVED: *Ayman Alqudwah*
 DATE: 4/24/2018

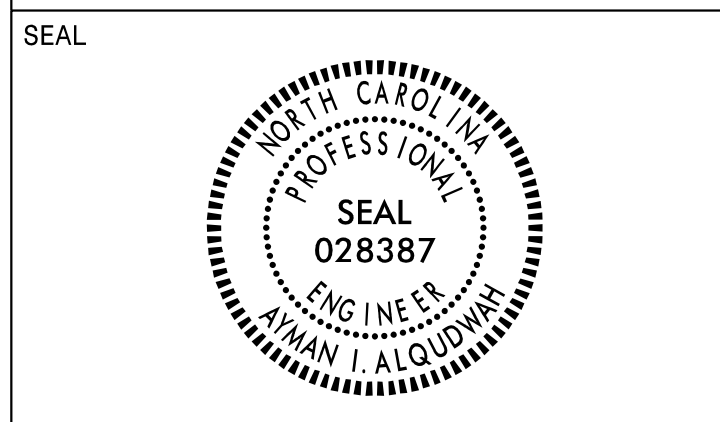

**DOCUMENT NOT CONSIDERED FINAL
 UNLESS ALL SIGNATURES COMPLETED**

SIGN NUMBER: 301 TYPE: D QUANTITY: 1 SIGN WIDTH: 7'-6" HEIGHT: 3'-0" TOTAL AREA: 22.5 Sq.Ft. BORDER TYPE: FLUSH RECESS: 0" WIDTH: 1" RADII: 3" NO. Z BARS: 1 LENGTH:	BACKG COLOR: Green / Green COPY COLOR: White SYMBOL X Y WID HT AR_Type D 7.2 23.3 8 12 AR_Type D 62 4.7 8 12	DESIGN BY: S.JOHNS PROJECT ID: R-2814C CHECKED BY: A.ALQUDWAH LOCATION: US 401 Mar 21, 2018 DIV: 5	<p style="text-align: center;">MOUNT ABOVE SIGN 501</p> <p style="text-align: center;">Spacing Factor is 1 unless specified otherwise</p>																																																																															
USE NOTES: 1,2 1. Legend and border(except those that are colored black) shall be direct applied Grade C sheeting. 2. Background shall be Grade C reflective sheeting.																																																																																		
<p style="text-align: center;">LETTER POSITIONS</p> <table border="1" style="width:100%; border-collapse: collapse;"> <thead> <tr> <th colspan="12">Letter spacings are to start of next letter</th> <th>Series/Size</th> </tr> <tr> <th colspan="12"></th> <th>Text Length</th> </tr> </thead> <tbody> <tr> <td>27.2</td><td>7.6</td><td>6.1</td><td>6.3</td><td>5.9</td><td>5.9</td><td>4.2</td><td>6.6</td><td>2.9</td><td>2.9</td><td>2.6</td><td>4.7</td><td>7.2</td> <td>D 2000</td> </tr> <tr> <td colspan="12"></td> <td>55.7</td> </tr> <tr> <td>16</td><td>6.3</td><td>5.8</td><td>6</td><td>6.3</td><td>2.6</td><td>6.2</td><td>4.7</td><td>36</td><td colspan="3"></td> <td>D 2000</td> </tr> <tr> <td colspan="12"></td> <td>37.9</td> </tr> </tbody> </table> <p style="text-align: right;">FILENAME: Sign Designs NORTH CAROLINA D.O.T. SIGN DETAIL</p>				Letter spacings are to start of next letter												Series/Size													Text Length	27.2	7.6	6.1	6.3	5.9	5.9	4.2	6.6	2.9	2.9	2.6	4.7	7.2	D 2000													55.7	16	6.3	5.8	6	6.3	2.6	6.2	4.7	36				D 2000													37.9
Letter spacings are to start of next letter												Series/Size																																																																						
												Text Length																																																																						
27.2	7.6	6.1	6.3	5.9	5.9	4.2	6.6	2.9	2.9	2.6	4.7	7.2	D 2000																																																																					
												55.7																																																																						
16	6.3	5.8	6	6.3	2.6	6.2	4.7	36				D 2000																																																																						
												37.9																																																																						

SIGN NUMBER: 302 TYPE: D QUANTITY: 1 SIGN WIDTH: 7'-6" HEIGHT: 3'-0" TOTAL AREA: 22.5 Sq.Ft. BORDER TYPE: FLUSH RECESS: 0" WIDTH: 1" RADII: 3" NO. Z BARS: 1 LENGTH:	BACKG COLOR: Green / Green COPY COLOR: White SYMBOL X Y WID HT AR_Type D 16 22.2 8 12 AR_Type D 70.8 5.8 8 12	DESIGN BY: S.JOHNS PROJECT ID: R-2814C CHECKED BY: A.ALQUDWAH LOCATION: US 401 Mar 21, 2018 DIV: 5	<p style="text-align: center;">MOUNT ABOVE SIGN 509</p> <p style="text-align: center;">Spacing Factor is 1 unless specified otherwise</p>																																																																															
USE NOTES: 1,2 1. Legend and border(except those that are colored black) shall be direct applied Grade C sheeting. 2. Background shall be Grade C reflective sheeting.																																																																																		
<p style="text-align: center;">LETTER POSITIONS</p> <table border="1" style="width:100%; border-collapse: collapse;"> <thead> <tr> <th colspan="12">Letter spacings are to start of next letter</th> <th>Series/Size</th> </tr> <tr> <th colspan="12"></th> <th>Text Length</th> </tr> </thead> <tbody> <tr> <td>36</td><td>6.3</td><td>5.8</td><td>6</td><td>6.3</td><td>2.6</td><td>6.2</td><td>4.7</td><td>16</td><td colspan="3"></td> <td>D 2000</td> </tr> <tr> <td colspan="12"></td> <td>37.9</td> </tr> <tr> <td>7.2</td><td>7.6</td><td>6.1</td><td>6.3</td><td>5.9</td><td>5.9</td><td>4.2</td><td>6.6</td><td>2.9</td><td>2.9</td><td>2.6</td><td>4.7</td><td>27.2</td> <td>D 2000</td> </tr> <tr> <td colspan="12"></td> <td>55.7</td> </tr> </tbody> </table> <p style="text-align: right;">FILENAME: Sign Designs NORTH CAROLINA D.O.T. SIGN DETAIL</p>				Letter spacings are to start of next letter												Series/Size													Text Length	36	6.3	5.8	6	6.3	2.6	6.2	4.7	16				D 2000													37.9	7.2	7.6	6.1	6.3	5.9	5.9	4.2	6.6	2.9	2.9	2.6	4.7	27.2	D 2000													55.7
Letter spacings are to start of next letter												Series/Size																																																																						
												Text Length																																																																						
36	6.3	5.8	6	6.3	2.6	6.2	4.7	16				D 2000																																																																						
												37.9																																																																						
7.2	7.6	6.1	6.3	5.9	5.9	4.2	6.6	2.9	2.9	2.6	4.7	27.2	D 2000																																																																					
												55.7																																																																						

SIGN NUMBER: 303 TYPE: D QUANTITY: 1 SIGN WIDTH: 7'-6" HEIGHT: 3'-0" TOTAL AREA: 22.5 Sq.Ft. BORDER TYPE: FLUSH RECESS: 0" WIDTH: 1" RADII: 3" NO. Z BARS: 1 LENGTH:	BACKG COLOR: Green COPY COLOR: White SYMBOL X Y WID HT	DESIGN BY: S.JOHNS PROJECT ID: R-2814C CHECKED BY: A.ALQUDWAH LOCATION: US 401 Nov 09, 2016 DIV: 5	<p style="text-align: center;">MOUNT ABOVE SIGN 501</p> <p style="text-align: center;">Spacing Factor is 1 unless specified otherwise</p>																																																																																																																																				
USE NOTES: 1,2 1. Legend and border(except those that are colored black) shall be direct applied Grade C sheeting. 2. Background shall be Grade C reflective sheeting.																																																																																																																																							
<p style="text-align: center;">LETTER POSITIONS</p> <table border="1" style="width:100%; border-collapse: collapse;"> <thead> <tr> <th colspan="12">Letter spacings are to start of next letter</th> <th>Series/Size</th> </tr> <tr> <th colspan="12"></th> <th>Text Length</th> </tr> </thead> <tbody> <tr> <td>8</td><td>5.7</td><td>6.1</td><td>6.3</td><td>2.4</td><td>4.8</td><td>6</td><td>6.3</td><td>3.7</td><td>4.8</td><td>35.9</td><td colspan="2"></td> <td>D 2000</td> </tr> <tr> <td colspan="12"></td> <td>46.1</td> </tr> <tr> <td>72.2</td><td>4.4</td><td>5.4</td><td>8</td><td colspan="8"></td> <td>D 2000</td> </tr> <tr> <td colspan="12"></td> <td>9.8</td> </tr> <tr> <td>8</td><td>7.8</td><td>6.1</td><td>4</td><td>3.7</td><td>5.8</td><td>5.5</td><td>3.8</td><td>6.2</td><td>4.7</td><td>34.5</td><td colspan="2"></td> <td>D 2000</td> </tr> <tr> <td colspan="12"></td> <td>47.5</td> </tr> <tr> <td>69.5</td><td>7</td><td>5.4</td><td>8</td><td colspan="8"></td> <td>D 2000</td> </tr> <tr> <td colspan="12"></td> <td>12.5</td> </tr> </tbody> </table> <p style="text-align: right;">FILENAME: Sign Designs NORTH CAROLINA D.O.T. SIGN DETAIL</p>				Letter spacings are to start of next letter												Series/Size													Text Length	8	5.7	6.1	6.3	2.4	4.8	6	6.3	3.7	4.8	35.9			D 2000													46.1	72.2	4.4	5.4	8									D 2000													9.8	8	7.8	6.1	4	3.7	5.8	5.5	3.8	6.2	4.7	34.5			D 2000													47.5	69.5	7	5.4	8									D 2000													12.5
Letter spacings are to start of next letter												Series/Size																																																																																																																											
												Text Length																																																																																																																											
8	5.7	6.1	6.3	2.4	4.8	6	6.3	3.7	4.8	35.9			D 2000																																																																																																																										
												46.1																																																																																																																											
72.2	4.4	5.4	8									D 2000																																																																																																																											
												9.8																																																																																																																											
8	7.8	6.1	4	3.7	5.8	5.5	3.8	6.2	4.7	34.5			D 2000																																																																																																																										
												47.5																																																																																																																											
69.5	7	5.4	8									D 2000																																																																																																																											
												12.5																																																																																																																											

SIGN NUMBER: 304 TYPE: D QUANTITY: 1 SIGN WIDTH: 6'-0" HEIGHT: 3'-6" TOTAL AREA: 21.0 Sq.Ft. BORDER TYPE: FLUSH RECESS: 0" WIDTH: 1" RADII: 3" NO. Z BARS: 1 LENGTH:	BACKG COLOR: Green COPY COLOR: White SYMBOL X Y WID HT	DESIGN BY: S.JOHNS PROJECT ID: R-2814C CHECKED BY: A.ALQUDWAH LOCATION: US 401 Feb 19, 2018 DIV: 5	<p style="text-align: center;">MOUNT ABOVE SIGN 501</p> <p style="text-align: center;">Spacing Factor is 1 unless specified otherwise</p>																																																																																																												
USE NOTES: 1,2 1. Legend and border(except those that are colored black) shall be direct applied Grade C sheeting. 2. Background shall be Grade C reflective sheeting.																																																																																																															
<p style="text-align: center;">LETTER POSITIONS</p> <table border="1" style="width:100%; border-collapse: collapse;"> <thead> <tr> <th colspan="12">Letter spacings are to start of next letter</th> <th>Series/Size</th> </tr> <tr> <th colspan="12"></th> <th>Text Length</th> </tr> </thead> <tbody> <tr> <td>8.4</td><td>7.3</td><td>5.8</td><td>3.1</td><td>5.3</td><td>5.9</td><td>8.5</td><td>4</td><td>6</td><td>5.3</td><td>4.1</td><td>8.4</td><td colspan="2"></td> <td>EW 2000</td> </tr> <tr> <td colspan="12"></td> <td>55.2</td> </tr> <tr> <td>14.2</td><td>5.5</td><td>5.5</td><td>7.1</td><td>6.4</td><td>5.9</td><td>5.5</td><td>2.6</td><td>4.9</td><td>14.2</td><td colspan="3"></td> <td>E 2000</td> </tr> <tr> <td colspan="12"></td> <td>43.6</td> </tr> <tr> <td>18.1</td><td>6.1</td><td>6.4</td><td>6.4</td><td>5.9</td><td>5</td><td>6.1</td><td>18.1</td><td colspan="5"></td> <td>E 2000</td> </tr> <tr> <td colspan="12"></td> <td>35.9</td> </tr> </tbody> </table> <p style="text-align: right;">FILENAME: Sign Designs NORTH CAROLINA D.O.T. SIGN DETAIL</p>				Letter spacings are to start of next letter												Series/Size													Text Length	8.4	7.3	5.8	3.1	5.3	5.9	8.5	4	6	5.3	4.1	8.4			EW 2000													55.2	14.2	5.5	5.5	7.1	6.4	5.9	5.5	2.6	4.9	14.2				E 2000													43.6	18.1	6.1	6.4	6.4	5.9	5	6.1	18.1						E 2000													35.9
Letter spacings are to start of next letter												Series/Size																																																																																																			
												Text Length																																																																																																			
8.4	7.3	5.8	3.1	5.3	5.9	8.5	4	6	5.3	4.1	8.4			EW 2000																																																																																																	
												55.2																																																																																																			
14.2	5.5	5.5	7.1	6.4	5.9	5.5	2.6	4.9	14.2				E 2000																																																																																																		
												43.6																																																																																																			
18.1	6.1	6.4	6.4	5.9	5	6.1	18.1						E 2000																																																																																																		
												35.9																																																																																																			

04/24/18
 N:\TIP-Projects-R\2814C\Traffic\Signing\CADD\Signing Layout\Plans\2814C_Sign_3.dgn
 Users\johns

SIGN DESIGNS

APPROVED: *Ayman Alqudwah*
 DATE: 4/24/2018

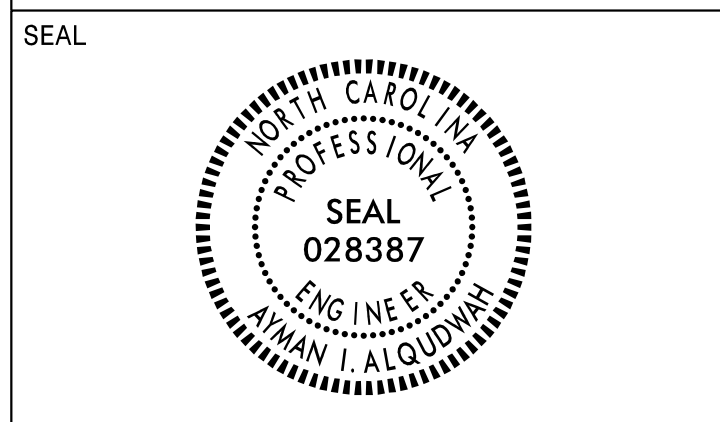

DOCUMENT NOT CONSIDERED FINAL UNLESS ALL SIGNATURES COMPLETED

SIGN NUMBER: 305 **BACKG COLOR: Green** **DESIGN BY: S.JOHNS** **CHECKED BY: A.ALOUDWAH** **Feb 20, 2018**
TYPE: D **COPY COLOR: White** **PROJECT ID: R-2814C** **LOCATION: US 401** **DIV: 5**

QUANTITY: 1

SYMBOL	X	Y	WID	HT
AR_Type D	7.8	22.2	8	12
AR_Type D	57.9	5.8	8	12

SIGN WIDTH: 6'-0"
 HEIGHT: 3'-6"
 TOTAL AREA: 21.0 Sq.Ft.

BORDER TYPE: FLUSH
 RECESS: 0"
 WIDTH: 1"
 RADII: 3"

MAT'L: 0.125" (3.2 mm) ALUMINUM

NO. Z BARS:
 LENGTH:

USE NOTES: 1,2
 1. Legend and border(except those that are colored black) shall be direct applied Grade C sheeting.
 2. Background shall be Grade C reflective sheeting.

Spacing Factor is 1 unless specified otherwise

LETTER POSITIONS

Letter spacings are to start of next letter													Series/Size
													Text Length
8.4	7.3	5.8	3.1	5.3	5.9	8.5	4	6	5.3	4.1	8.4		EM 2000
													55.2
23.8	6.8	7.1	5.9	4.5	23.8								E 2000
													24.4
18.1	6.1	6.4	6.4	5.9	5	6.1	18.1						E 2000
													35.9

FILENAME: Sign Designs **NORTH CAROLINA D.O.T. SIGN DETAIL**

SIGN NUMBER: 306 **BACKG COLOR: Green / Green** **DESIGN BY: S.JOHNS** **CHECKED BY: A.ALOUDWAH** **Mar 21, 2018**
TYPE: D **COPY COLOR: White** **PROJECT ID: R-2814C** **LOCATION: US 401** **DIV: 5**

QUANTITY: 1

SYMBOL	X	Y	WID	HT
AR_Type D	7.8	22.2	8	12
AR_Type D	57.9	5.8	8	12

SIGN WIDTH: 8'-0"
 HEIGHT: 3'-0"
 TOTAL AREA: 24.0 Sq.Ft.

BORDER TYPE: FLUSH
 RECESS: 0"
 WIDTH: 1"
 RADII: 3"

MAT'L: 0.125" (3.2 mm) ALUMINUM

NO. Z BARS:
 LENGTH:

USE NOTES: 1,2
 1. Legend and border(except those that are colored black) shall be direct applied Grade C sheeting.
 2. Background shall be Grade C reflective sheeting.

Spacing Factor is 1 unless specified otherwise

LETTER POSITIONS

Letter spacings are to start of next letter													Series/Size
													Text Length
27.8	7.8	6.1	5.8	4.7	8	5.7	6.2	3.7	5.4	4.1	3.2	7.8	D 2000
													60.5
26.1	6.6	6.3	6.2	4.7	46.1								D 2000
													23.8

FILENAME: Sign Designs **NORTH CAROLINA D.O.T. SIGN DETAIL**

SIGN NUMBER: 307 **BACKG COLOR: Green / Green** **DESIGN BY: S.JOHNS** **CHECKED BY: A.ALOUDWAH** **Mar 21, 2018**
TYPE: D **COPY COLOR: White** **PROJECT ID: R-2814C** **LOCATION: US 401** **DIV: 5**

QUANTITY: 1

SYMBOL	X	Y	WID	HT
AR_Type D	26.1	22.2	8	12
AR_Type D	76.2	5.8	8	12

SIGN WIDTH: 8'-0"
 HEIGHT: 3'-0"
 TOTAL AREA: 24.0 Sq.Ft.

BORDER TYPE: FLUSH
 RECESS: 0"
 WIDTH: 1"
 RADII: 3"

MAT'L: 0.125" (3.2 mm) ALUMINUM

NO. Z BARS:
 LENGTH:

USE NOTES: 1,2
 1. Legend and border(except those that are colored black) shall be direct applied Grade C sheeting.
 2. Background shall be Grade C reflective sheeting.

Spacing Factor is 1 unless specified otherwise

LETTER POSITIONS

Letter spacings are to start of next letter													Series/Size
													Text Length
46.1	6.6	6.3	6.2	4.7	26.1								D 2000
													23.8
7.8	7.8	6.1	5.8	4.7	8	5.7	6.2	3.7	5.4	4.1	3.2	27.8	D 2000
													60.5

FILENAME: Sign Designs **NORTH CAROLINA D.O.T. SIGN DETAIL**

SIGN NUMBER: 308 **BACKG COLOR: Green** **DESIGN BY: S.JOHNS** **CHECKED BY: A.ALOUDWAH** **Feb 20, 2018**
TYPE: D **COPY COLOR: White** **PROJECT ID: R-2814C** **LOCATION: US 401** **DIV: 5**

QUANTITY: 1

SYMBOL	X	Y	WID	HT
AR_Type D	7.8	22.2	8	12
AR_Type D	57.9	5.8	8	12

SIGN WIDTH: 7'-0"
 HEIGHT: 3'-0"
 TOTAL AREA: 21.0 Sq.Ft.

BORDER TYPE: FLUSH
 RECESS: 0"
 WIDTH: 1"
 RADII: 3"

MAT'L: 0.125" (3.2 mm) ALUMINUM

NO. Z BARS:
 LENGTH:

USE NOTES: 1,2
 1. Legend and border(except those that are colored black) shall be direct applied Grade C sheeting.
 2. Background shall be Grade C reflective sheeting.

Spacing Factor is 1 unless specified otherwise

LETTER POSITIONS

Letter spacings are to start of next letter													Series/Size
													Text Length
7.3	6.3	6.2	2.6	5.4	4.2	6.6	2.9	2.9	2.6	4.7	32.4		D 2000
													44.2
71.2	5.4	7.3											D 2000
													5.4
7.3	6.2	6.1	2.6	5.8	2.6	6.4	4.7	42.3					D 2000
													34.4
2	3												D 2000
													13.1

FILENAME: Sign Designs **NORTH CAROLINA D.O.T. SIGN DETAIL**

04/24/18
 N:\TIP-Projects-R\R2814C\Traffic\Signing\CADD\Signing Layout\Plans\R2814C_Sign_3.dgn
 Users\johns

SIGN DESIGNS

APPROVED: *Ayman Aloudwah*
DATE: 4/24/2018



**DOCUMENT NOT CONSIDERED FINAL
UNLESS ALL SIGNATURES COMPLETED**

SIGN NUMBER: 309	BACK COLOR: Green	DESIGN BY: S.JOHNS	CHECKED BY: A.ALQUDWAH	Feb 20, 2018
TYPE: D	COPY COLOR: White	PROJECT ID: R-2814C	LOCATION: US 401	DIV: 5
QUANTITY: 1				
SIGN WIDTH: 7'-0"				
HEIGHT: 3'-0"				
TOTAL AREA: 21.0 Sq.Ft.				
BORDER TYPE: FLUSH				
RECESS: 0"				
WIDTH: 1"				
RADII: 3"				
NO. Z BARS:	MAT'L: 0.125" (3.2 mm) ALUMINUM			
LENGTH:				

USE NOTES: 1,2

- Legend and border(except those that are colored black) shall be direct applied Grade C sheeting.
- Background shall be Grade C reflective sheeting.

Spacing Factor is 1 unless specified otherwise

LETTER POSITIONS													Series/Size
Letter spacings are to start of next letter													Text Length
	L	o	u	i	s	b	u	r	g				D 2000
8.4	5.7	6.1	6.3	2.4	4.8	6	6.3	3.7	4.8	29.5			46.1
	7												D 2000
70.1	5.4	8.4											5.4
	W	a	r	r	e	n	t	o	n				D 2000
8.4	7.8	6.1	4	3.7	5.8	5.5	3.8	6.2	4.7	28			47.5
	3	1											D 2000
66.5	7	2	8.4										9

FILENAME: Sign Designs NORTH CAROLINA D.O.T. SIGN DETAIL

04/24/18
N:\TIP-Projects-R\R2814C\Traffic\Signing\CADD\Signing Layout\Plans\R2814C_Sign_3.dgn
Users\johns

SIGN DESIGNS

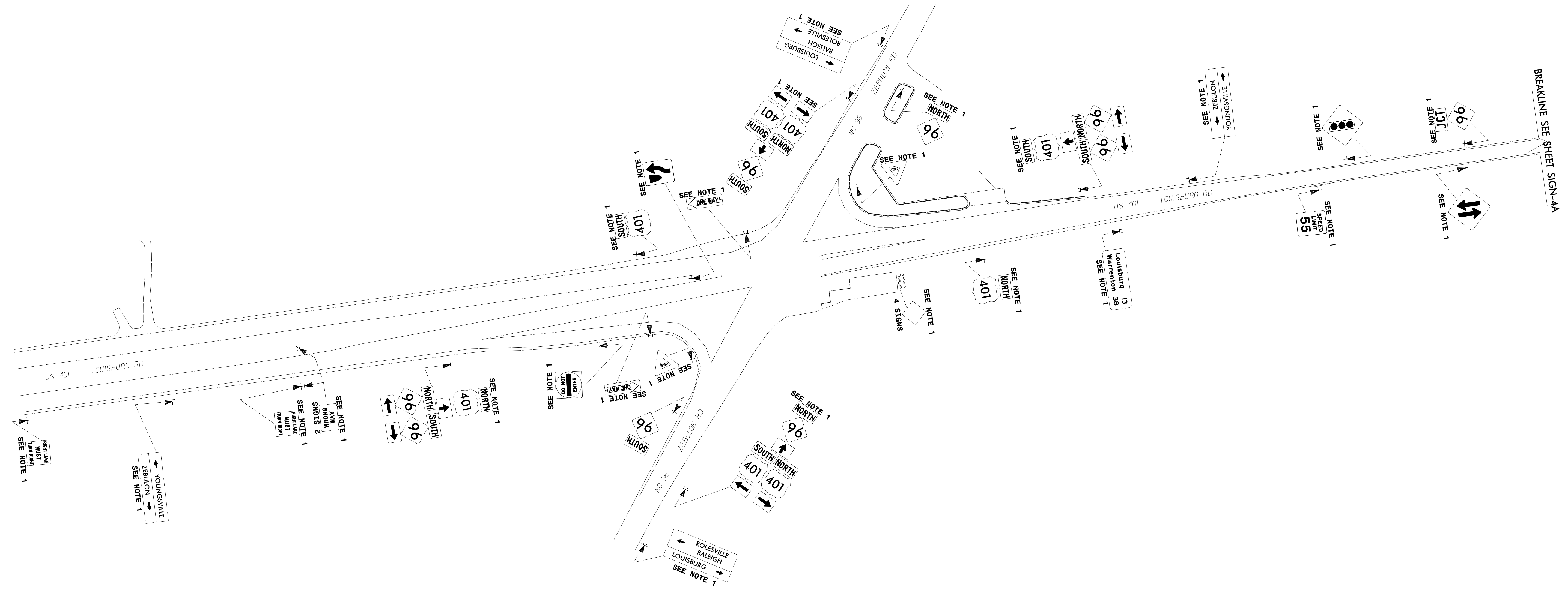

1. DISPOSAL OF SIGN SYSTEM, U-CHANNEL
2. DISPOSAL OF SUPPORT, U-CHANNEL
3. SIGN ERECTION, RELOCATE SIGN TYPE E

**EXISTING SIGNS
-L- US 401(LOUISBURG RD)**

04/24/18
 N:\TIP\Projects-R\R2814c\Traffic\Signing\CADD\Signing_Layout\Plans\R-2814C_Sign_4.dgn
 Users\johns

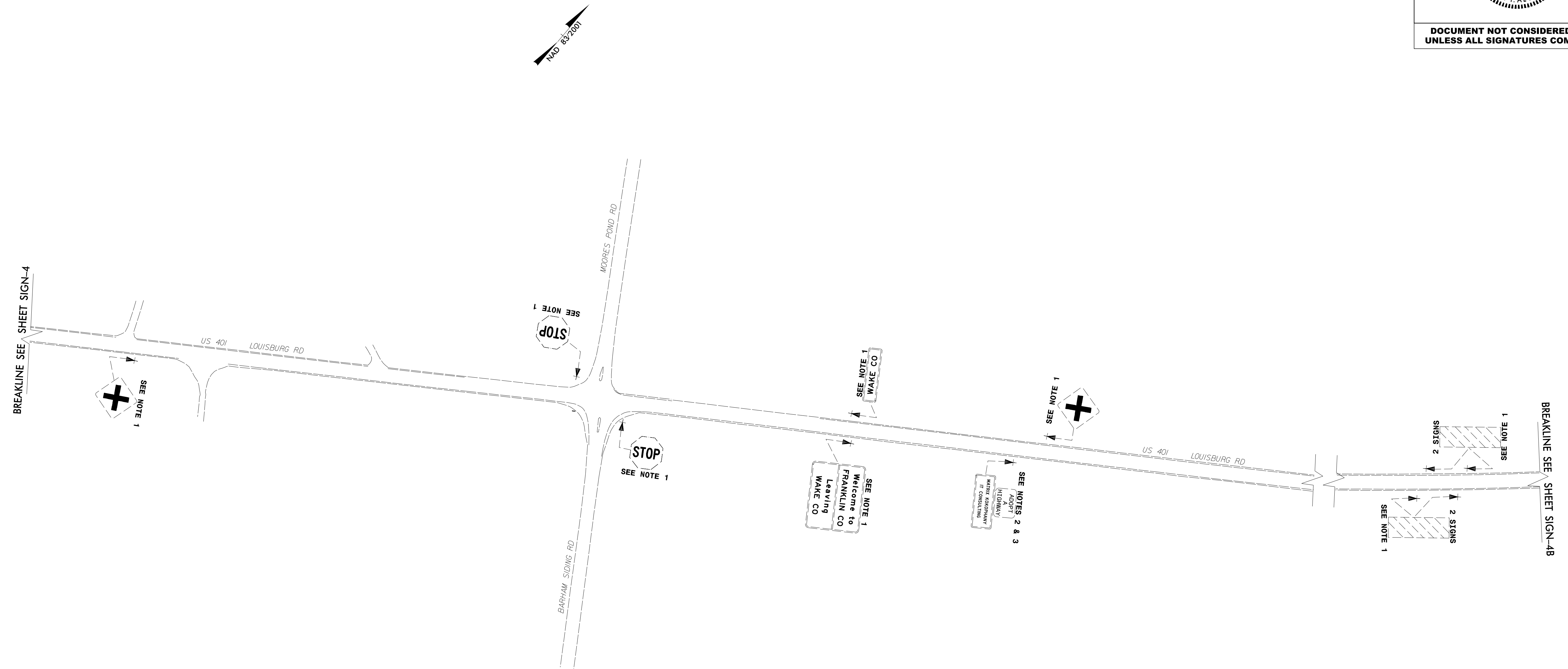

1. DISPOSAL OF SIGN SYSTEM, U-CHANNEL
2. DISPOSAL OF SUPPORT, U-CHANNEL
3. SIGN ERECTION, RELOCATE SIGN TYPE E

**EXISTING SIGNS
-L- US 401(LOUISBURG RD)**

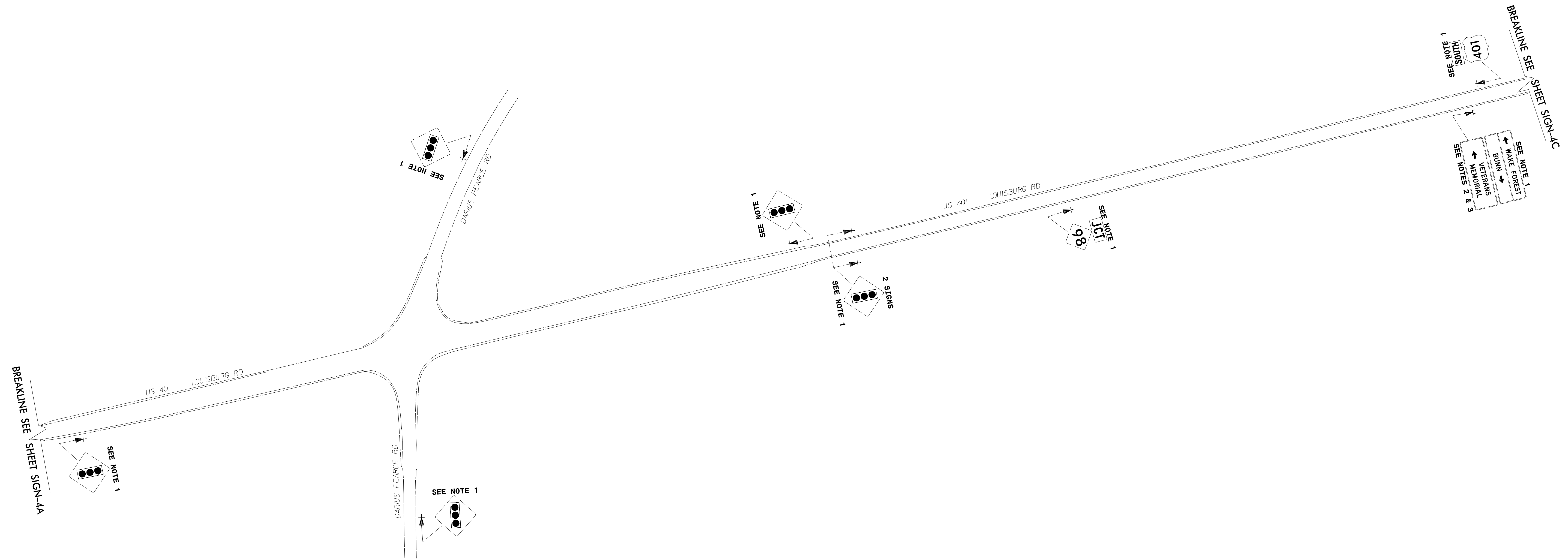

PROJECT NOTES

1. DISPOSAL OF SIGN SYSTEM, U-CHANNEL
2. DISPOSAL OF SUPPORT, U-CHANNEL
3. SIGN ERECTION, RELOCATE SIGN TYPE E

**EXISTING SIGNS
-L- US 401 (LOUISBURG RD)**

APPROVED: *Ayman Alqudwah*
DATE: 4/24/2018



DOCUMENT NOT CONSIDERED FINAL
UNLESS ALL SIGNATURES COMPLETED

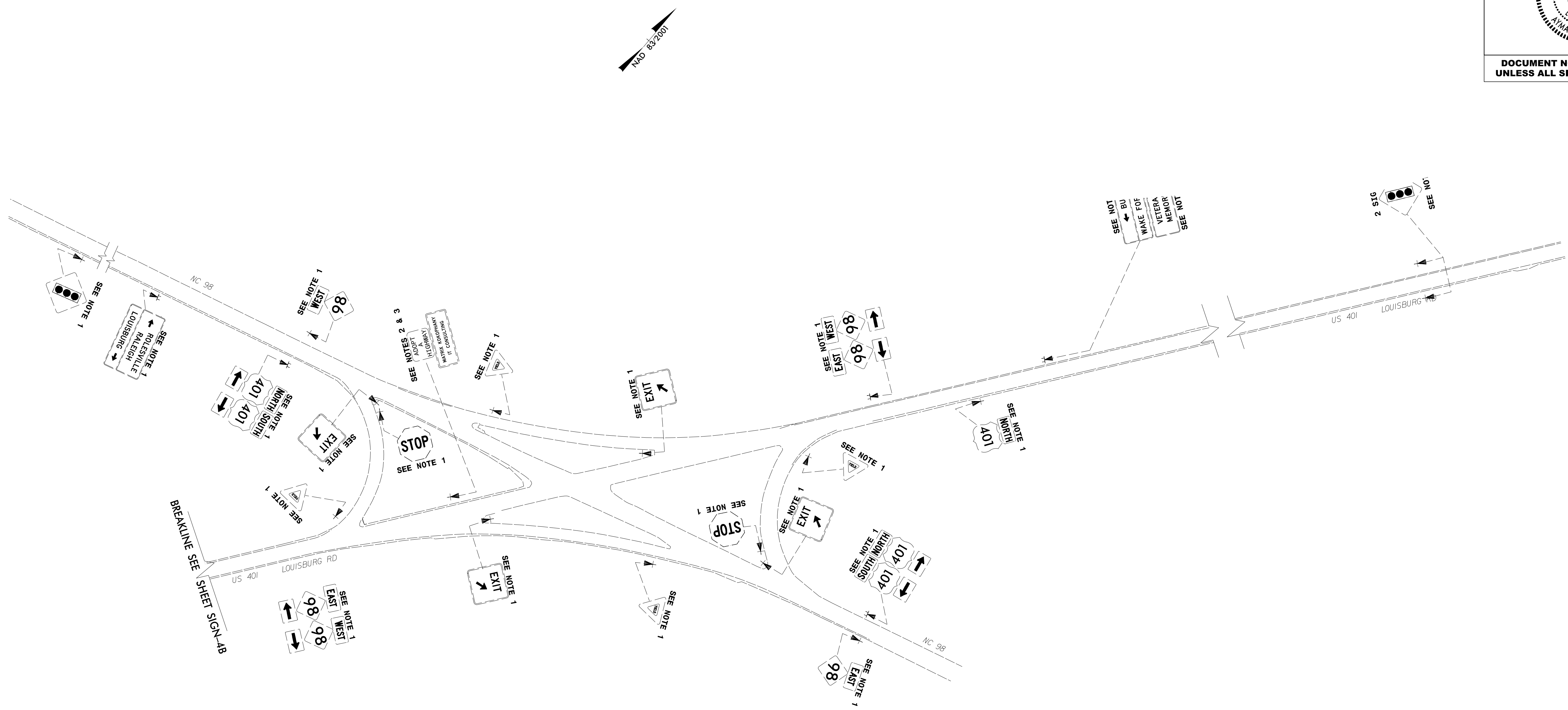

PROJECT NOTES

1. DISPOSAL OF SIGN SYSTEM, U-CHANNEL
2. DISPOSAL OF SUPPORT, U-CHANNEL
3. SIGN ERECTION, RELOCATE SIGN TYPE E

**EXISTING SIGNS
-L- US 401 (LOUISBURG RD)**

04/24/18
N:\TIP\Projects-R\R2814c\Traffic\Signing\CADD\Signing_Layout\Plans\R-2814C_Sign_4C.dgn
Users\johns

TIP NO. R-2814C	SHEET NO. SIGN-6
Approved by: <i>Ayman Alqudwah</i> <small>F3243CAF98472...</small>	
DATE: 4/24/2018	
SEAL 	
DOCUMENT NOT CONSIDERED FINAL UNLESS ALL SIGNATURES COMPLETED	

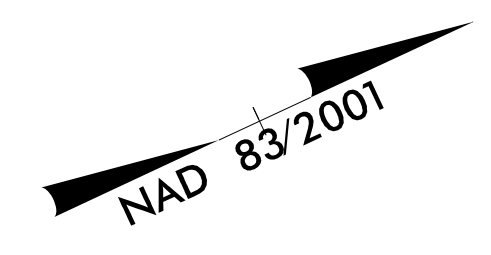

50

55

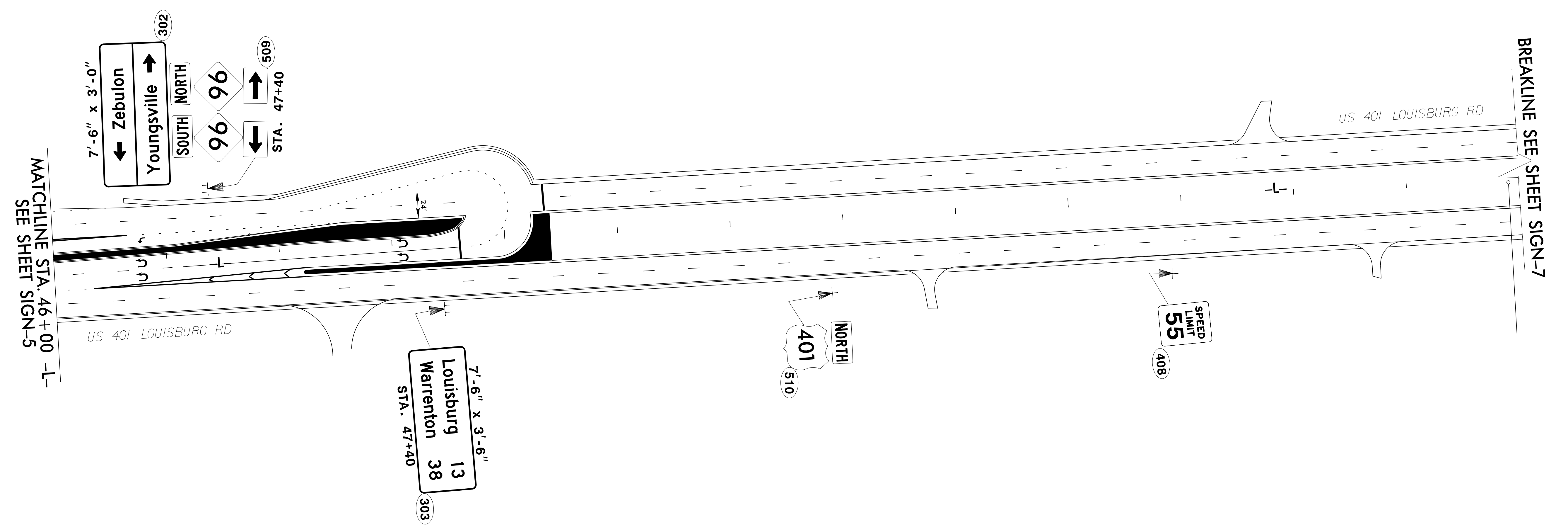

MATCHLINE STA. 46+00 -L- SEE SHEET SIGN-5

BREAKLINE SEE SHEET SIGN-7

**PROPOSED SIGNS
STA. 46+00 TO STA. 59+00
-L- US 401 (LOUISBURG RD)**

04/24/18
N:\TIP\Projects-R\R2814c\Traffic\Signing\CADD\Signing Layout\Plans\R2814C_Sign_6.dgn
Users\johns

TIP NO. R-2814C	SHEET NO. SIGN-7
APPROVED: <i>Ayman Alquodwah</i> <small>Professional Engineer</small>	
DATE: 4/24/2018	
SEAL	
DOCUMENT NOT CONSIDERED FINAL UNLESS ALL SIGNATURES COMPLETED	

NAD 83 NSRS 2007

75

80

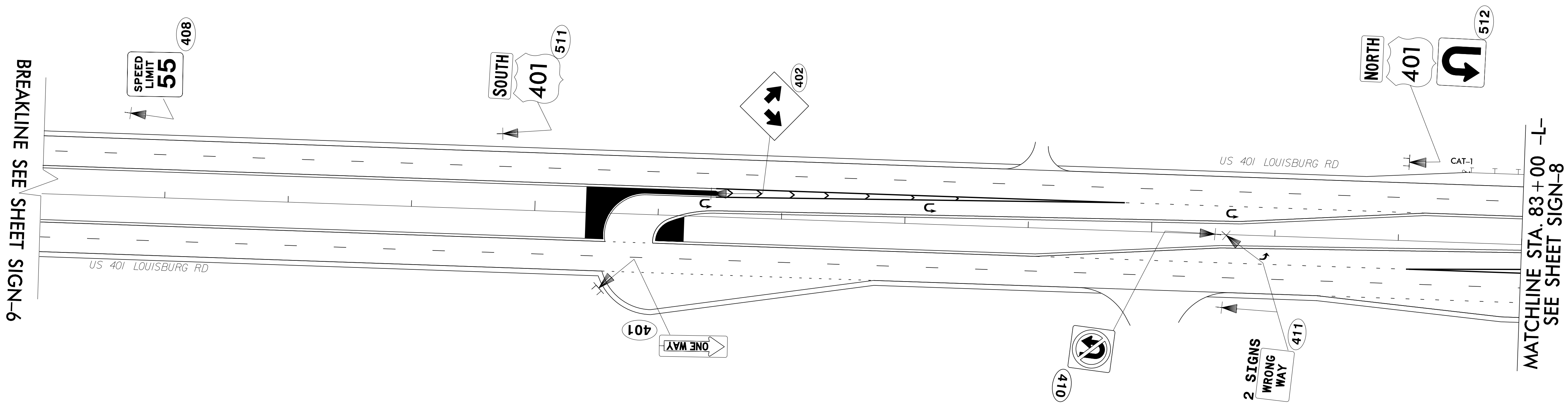

**PROPOSED SIGNS
STA. 71+00 TO STA. 83+00
-L- US 401 (LOUISBURG RD)**

04/24/18
 N:\TIP\Projects-R\R2814c\Traffic\Signing\CADD\Signing_Layout\Plans\R2814C_Sign-7.dgn
 Users\johns

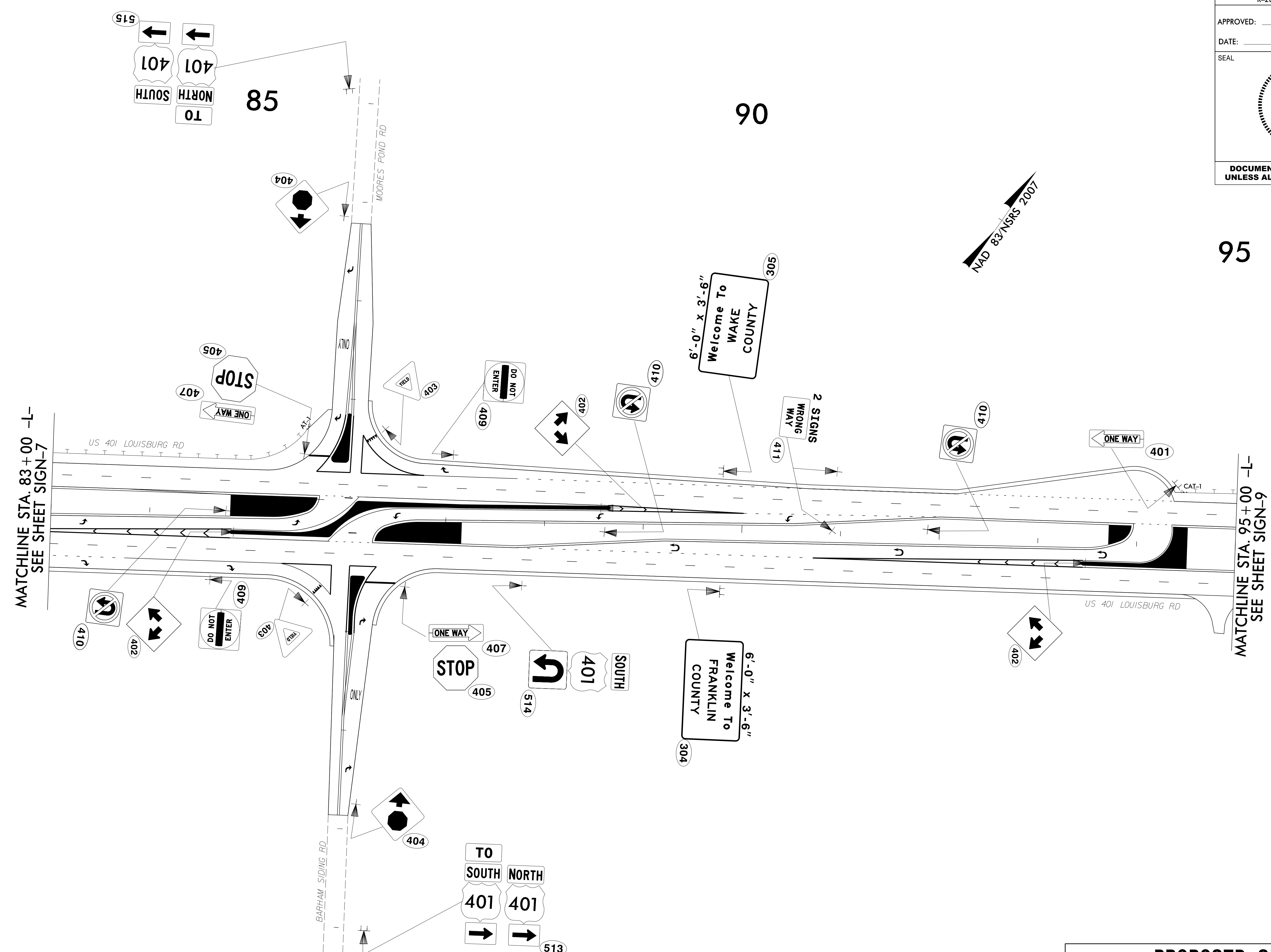

**PROPOSED SIGNS
STA. 83+00 TO STA. 95+00
-L- US 401 (LOUISBURG RD)**

04/24/18
N:\TIP\Projects-R\R2814c\Traffic\Signing\CADD\Signing_Layout\Plans\R2814C_Sign_8.dgn
Users\johns

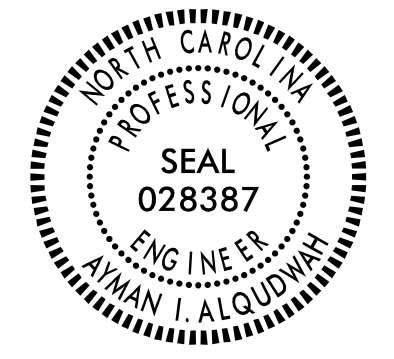
TIP NO. R-2814C	SHEET NO. SIGN-9
APPROVED: <i>Ayman Alqudus</i> <small>F3242SCAF198472</small>	
DATE: 4/24/2018	
SEAL 	
DOCUMENT NOT CONSIDERED FINAL UNLESS ALL SIGNATURES COMPLETED	

NAD 83 NGRS 2007

95

100

105

MATCHLINE STA. 95+00 -L-
SEE SHEET SIGN-8

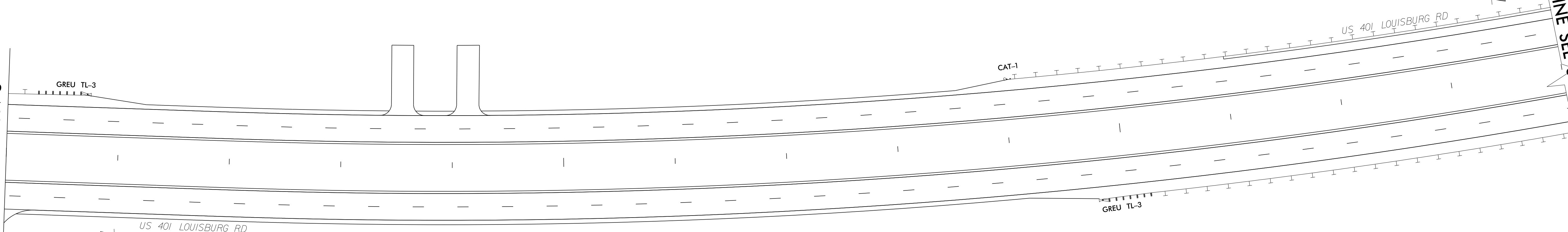

BREAKLINE SEE SHEET SIGN-10

04/24/18
 N:\TIP\Projects-R\R2814\Traffic\Signing\CADD\Signing_Layout\Plans\R2814C_Sign_9.dgn
 Users\johns

**PROPOSED SIGNS
STA. 95+00 TO STA. 109+00
-L- US 401 (LOUISBURG RD)**

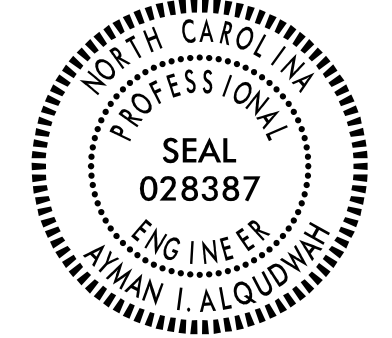
TIP NO. R-2814C	SHEET NO. SIGN-10
APPROVED: <i>Ayman Alqudwah</i> F53ACSCAF98472...	
DATE: 4/24/2018	
SEAL 	
DOCUMENT NOT CONSIDERED FINAL UNLESS ALL SIGNATURES COMPLETED	

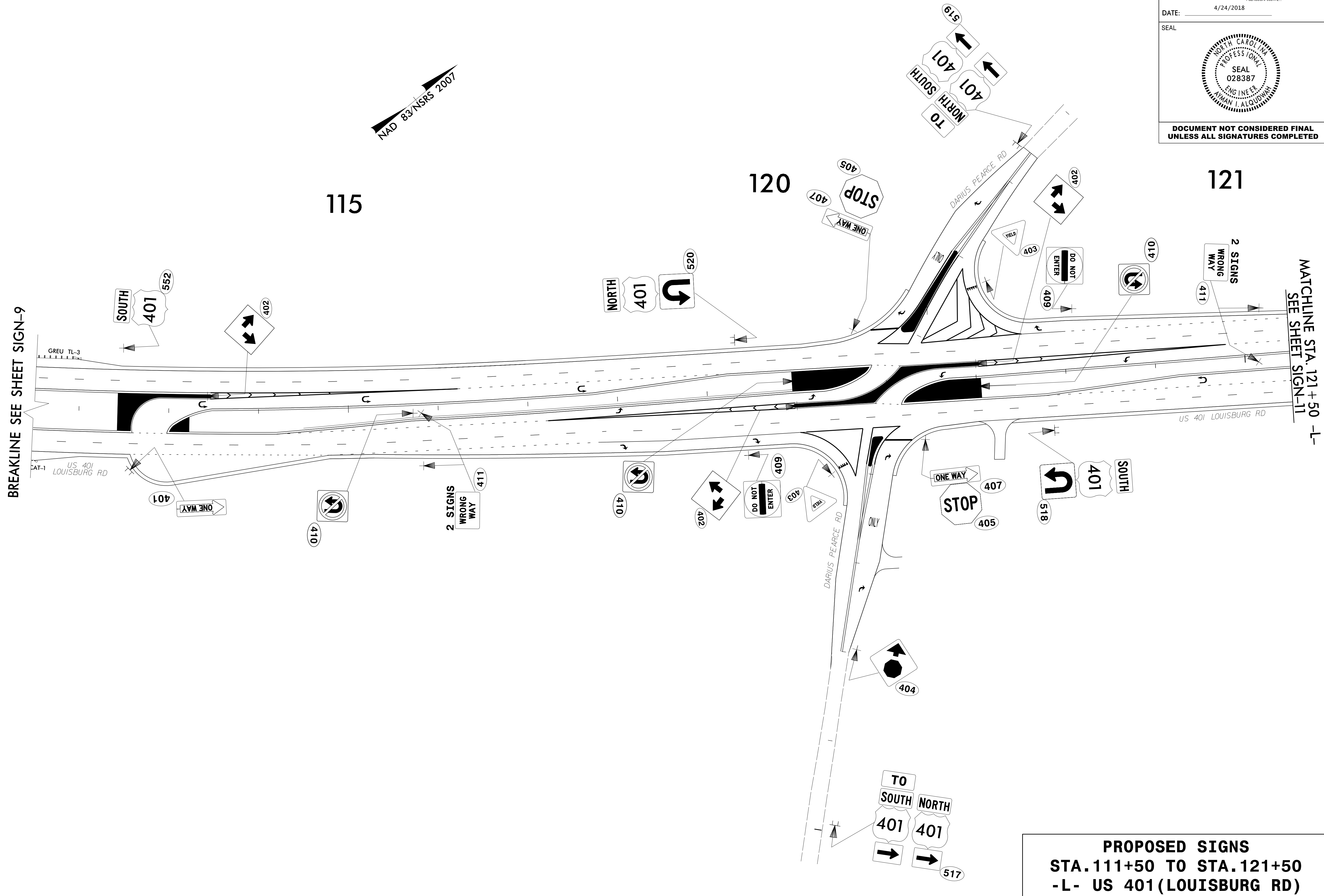

PROPOSED SIGNS
STA. 111+50 TO STA. 121+50
-L- US 401 (LOUISBURG RD)

04/24/18
 N:\TIP\Projects-R\R2814C\Traffic\Signing\CADD\Signing\Layout\Plans\R2814C_Sign_10.dgn
 Users\johns

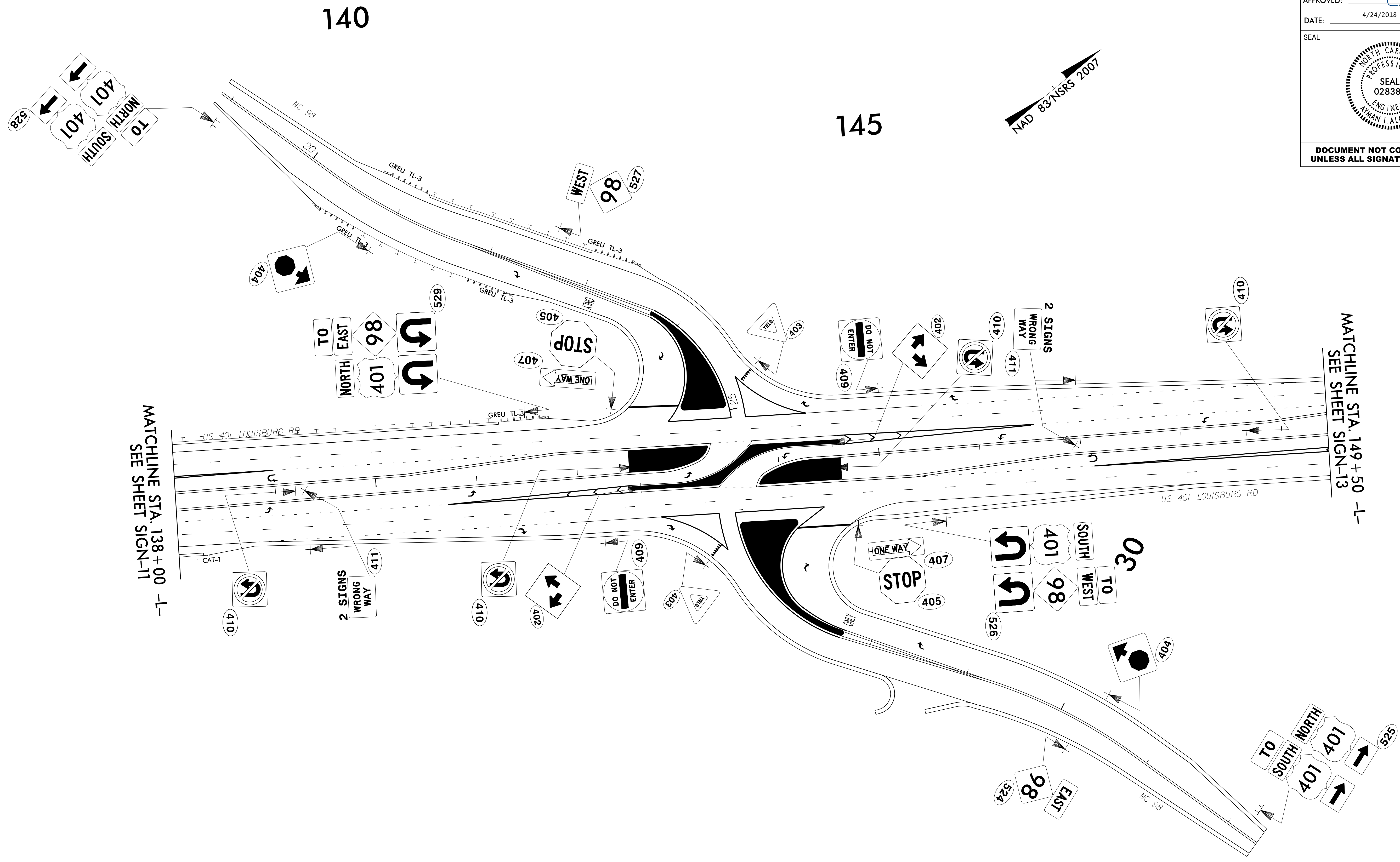

04/24/18
 N:\TIP\Projects-R\R2814C-Traffic\Signing\CADD\Signing_Layout\Plans\R2814C_Sign_12.dgn
 Users\johns

PROPOSED SIGNS
STA. 138+00 TO STA. 149+50
-L- US 401 (LOUISBURG RD)

150

155

160

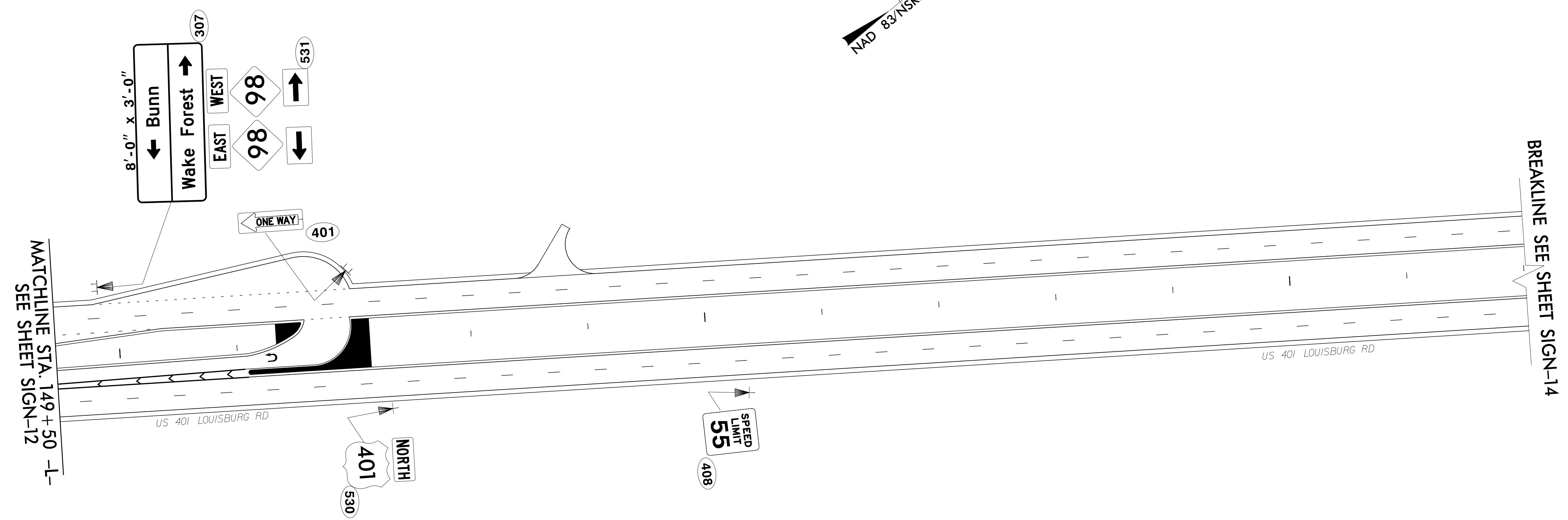

PROPOSED SIGNS
STA. 149+50 TO STA. 162+00
-L- US 401 (LOUISBURG RD)

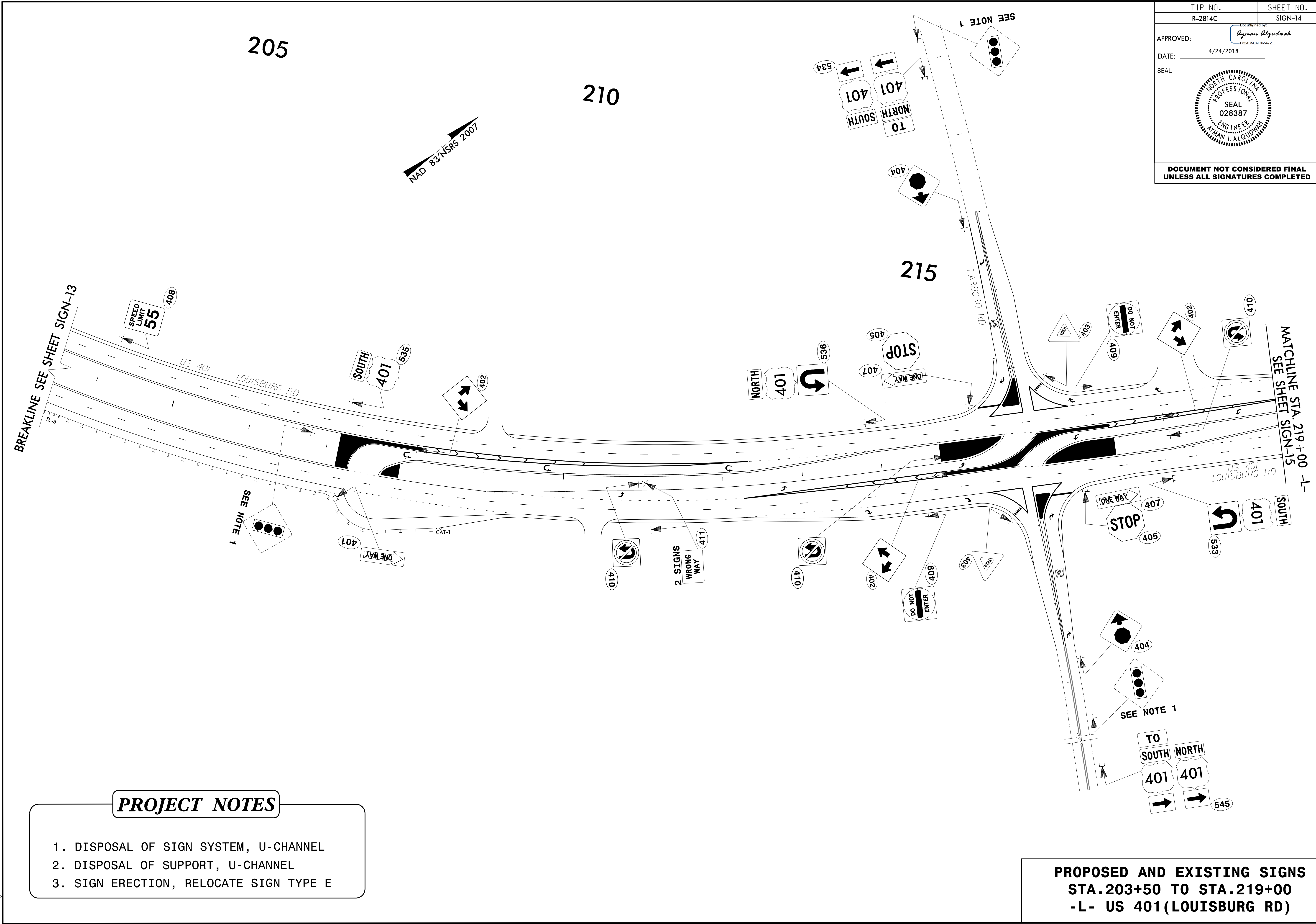

PROJECT NOTES

1. DISPOSAL OF SIGN SYSTEM, U-CHANNEL
2. DISPOSAL OF SUPPORT, U-CHANNEL
3. SIGN ERECTION, RELOCATE SIGN TYPE E

**PROPOSED AND EXISTING SIGNS
STA. 203+50 TO STA. 219+00
-L- US 401 (LOUISBURG RD)**

04/24/18
 N:\TIP\Projects-R\R2814C-Traffic\Signing\CADD\Signing_Layout\Plans\R2814C_Sign_14.dgn
 Users\johns

220

225

230

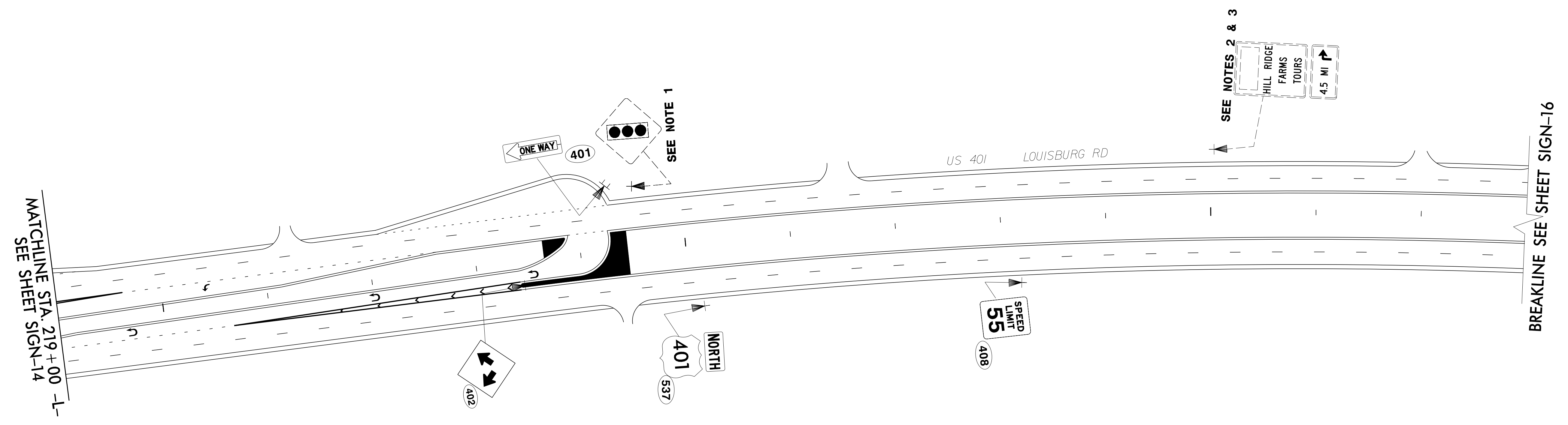
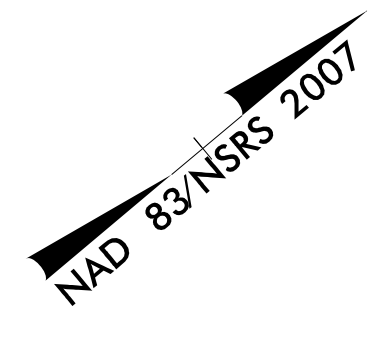

MATCHLINE STA. 219+00 -L-
SEE SHEET SIGN-14

BREAKLINE SEE SHEET SIGN-16

PROJECT NOTES

1. DISPOSAL OF SIGN SYSTEM, U-CHANNEL
2. DISPOSAL OF SUPPORT, U-CHANNEL
3. SIGN ERECTION, RELOCATE SIGN TYPE E

**PROPOSED AND EXISTING SIGNS
STA. 219+00 TO STA. 233+00
-L- US 401 (LOUISBURG RD)**

250

255

260

265

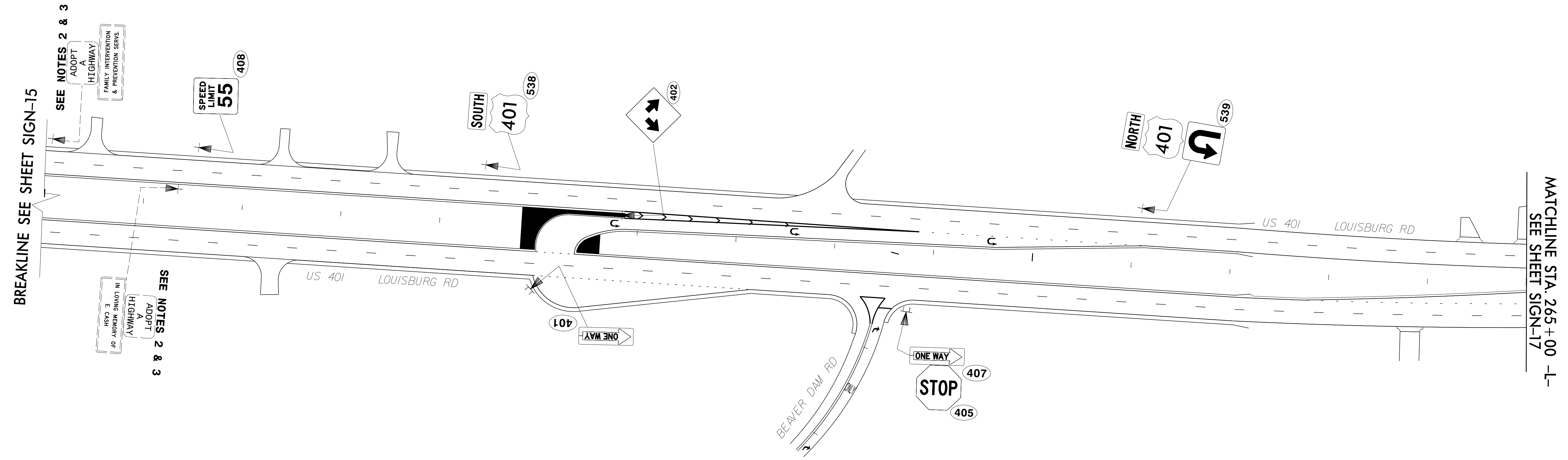
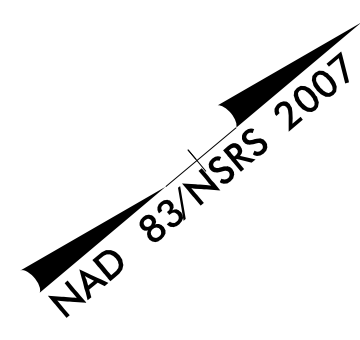

PROJECT NOTES

1. DISPOSAL OF SIGN SYSTEM, U-CHANNEL
2. DISPOSAL OF SUPPORT, U-CHANNEL
3. SIGN ERECTION, RELOCATE SIGN TYPE E

**PROPOSED AND EXISTING SIGNS
STA.250+00 TO STA.265+00
-L- US 401(LOUISBURG RD)**

04/24/18
 N:\TIP\Projects-R\R2814c\Traffic\Signing\CADD\Signing Layout\Plans\R2814C_Sign-16.dgn
 Users\johns

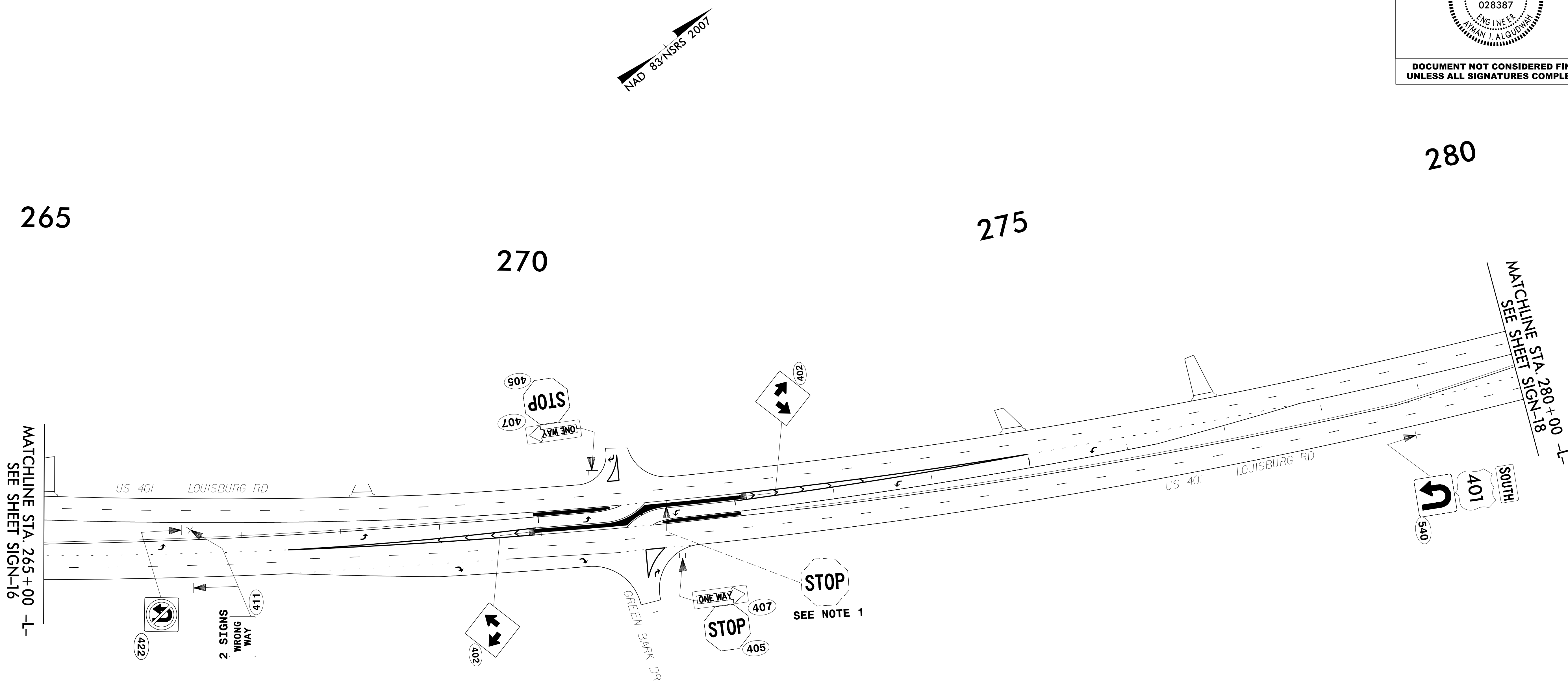

PROJECT NOTES

1. DISPOSAL OF SIGN SYSTEM, U-CHANNEL
2. DISPOSAL OF SUPPORT, U-CHANNEL
3. SIGN ERECTION, RELOCATE SIGN TYPE E

**PROPOSED AND EXISTING SIGNS
STA. 265+00 TO STA. 280+00
-L- US 401 (LOUISBURG RD)**

04/24/18
 N:\TIP\Projects-R\R2814C\Traffic\Signing\CADD\Signing_Layout\Plans\R2814C_Sign_17.dgn
 Users\johns

TIP NO. R-2814C	SHEET NO. SIGN-18
APPROVED: <i>Ayman Alqudus</i> F3045CAF98472	
DATE: 4/24/2018	
SEAL 	
DOCUMENT NOT CONSIDERED FINAL UNLESS ALL SIGNATURES COMPLETED	

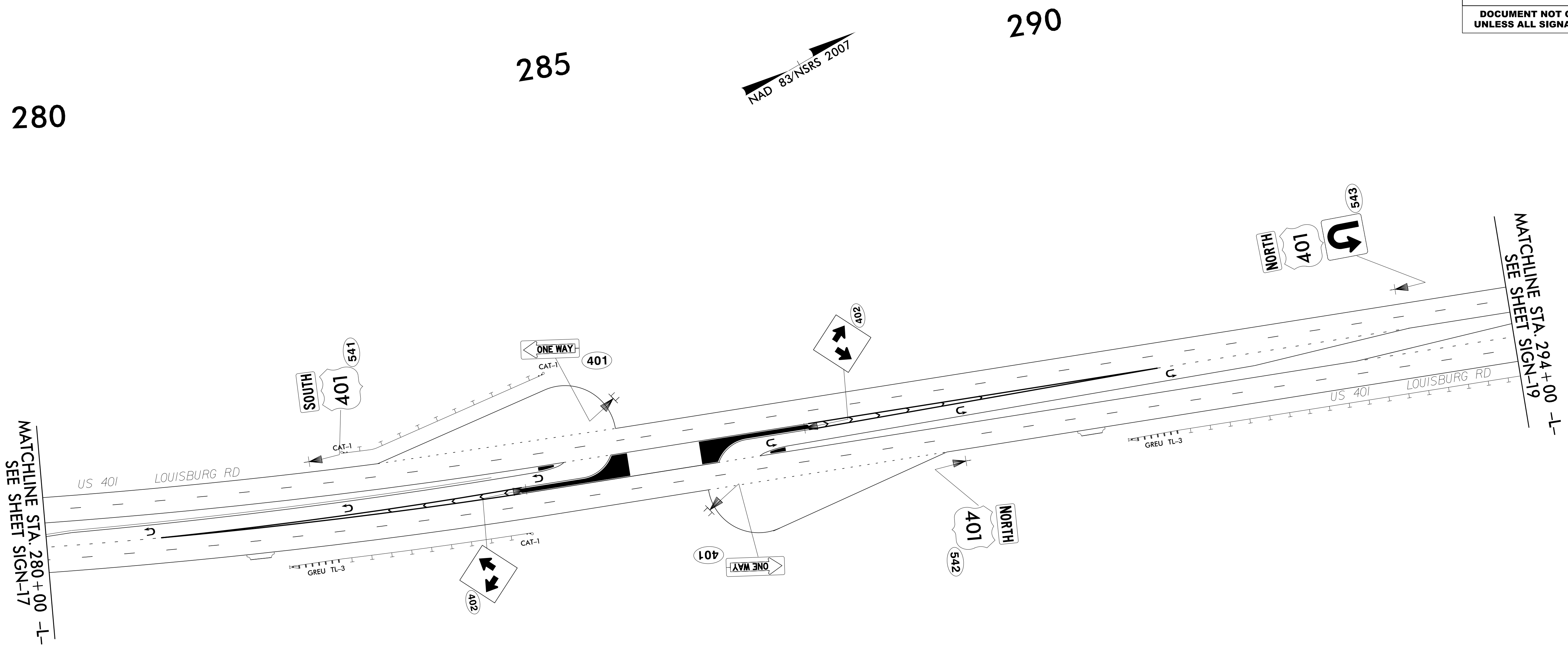

**PROPOSED SIGNS
 STA.280+00 TO STA.294+00
 -L- US 401(LOUISBURG RD)**

04/24/18
 N:\TIP\Projects-R\R2814c\Traffic\Signing\CADD\Signing Layout\Plans\R2814C_Sign-18.dgn
 Users\johns

295

300

305

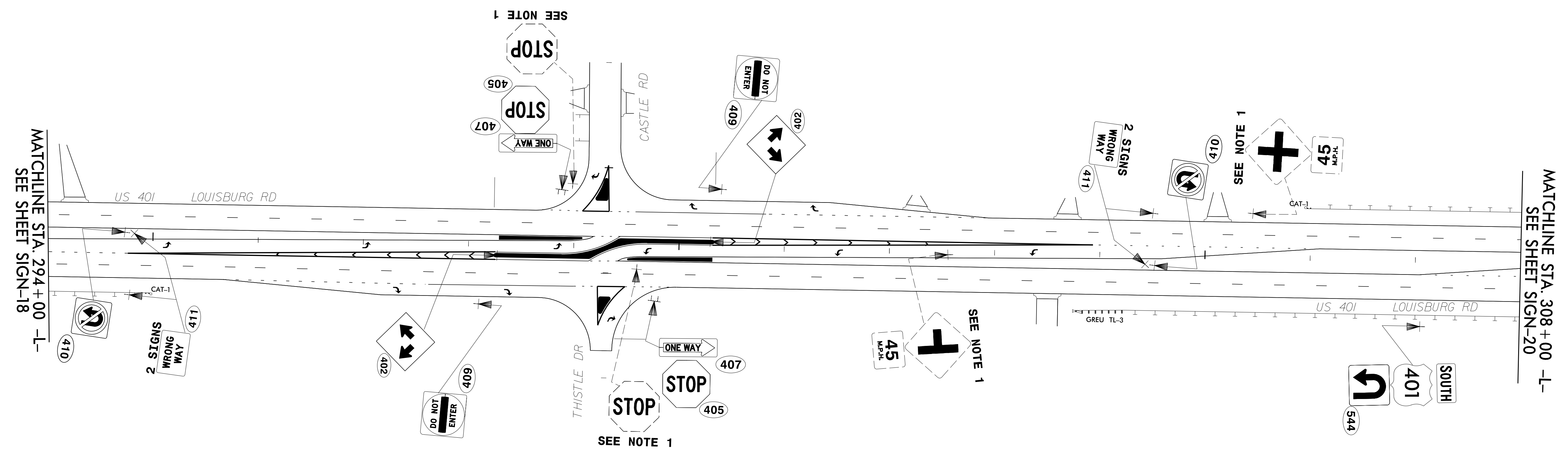
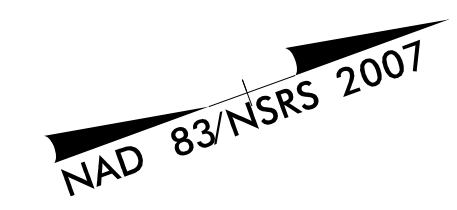

PROJECT NOTES

1. DISPOSAL OF SIGN SYSTEM, U-CHANNEL
2. DISPOSAL OF SUPPORT, U-CHANNEL
3. SIGN ERECTION, RELOCATE SIGN TYPE E

**PROPOSED AND EXISTING SIGNS
STA. 294+00 TO STA. 308+00
-L- US 401 (LOUISBURG RD)**

04/24/18
 N:\TIP\Projects-R\R2814c\Traffic\Signing\CADD\Signing_Layout\Plans\R2814C_Sign-19.dgn
 Users\johns

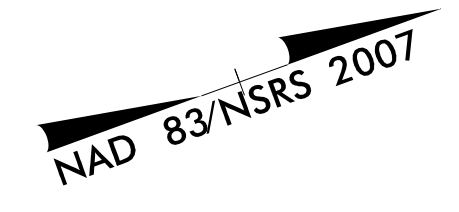

310

315

320

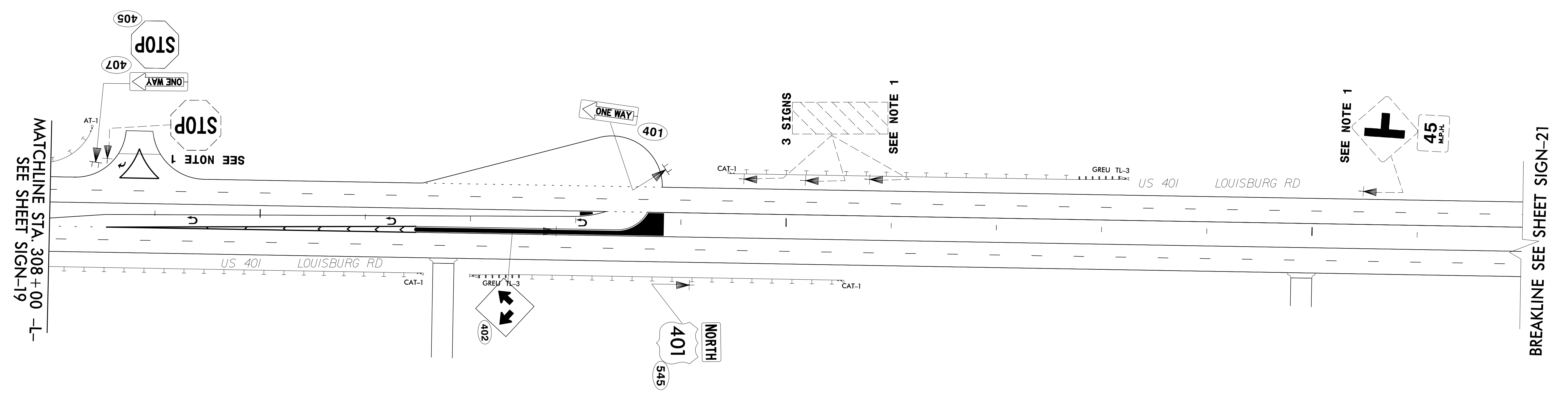

PROJECT NOTES

1. DISPOSAL OF SIGN SYSTEM, U-CHANNEL
2. DISPOSAL OF SUPPORT, U-CHANNEL
3. SIGN ERECTION, RELOCATE SIGN TYPE E

**PROPOSED AND EXISTING SIGNS
STA. 308+00 TO STA. 322+00
-L- US 401 (LOUISBURG RD)**

04/24/18
 N:\TIP\Projects-R\R2814C\Traffic\Signing\CADD\Signing Layout\Plans\R2814C_Sign-20.dgn
 Users\johns

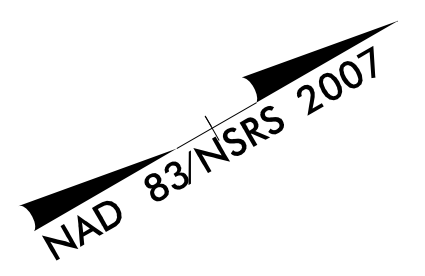

345

350

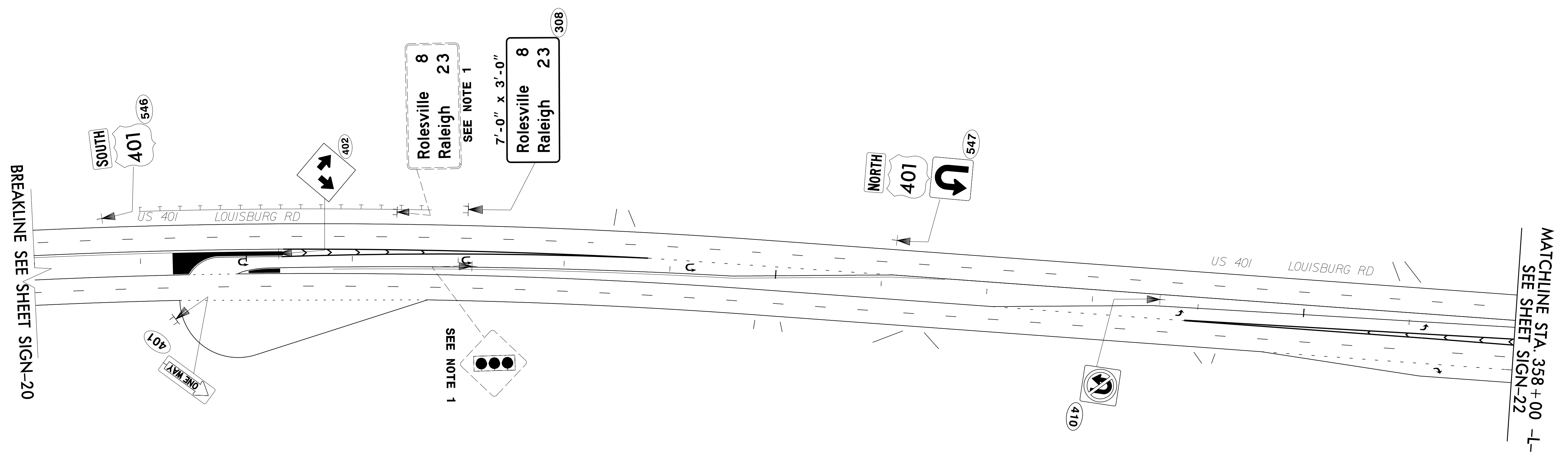

PROJECT NOTES

1. DISPOSAL OF SIGN SYSTEM, U-CHANNEL
2. DISPOSAL OF SUPPORT, U-CHANNEL
3. SIGN ERECTION, RELOCATE SIGN TYPE E

**PROPOSED AND EXISTING SIGNS
STA.343+00 TO STA.385+00
-L- US 401(LOUISBURG RD)**

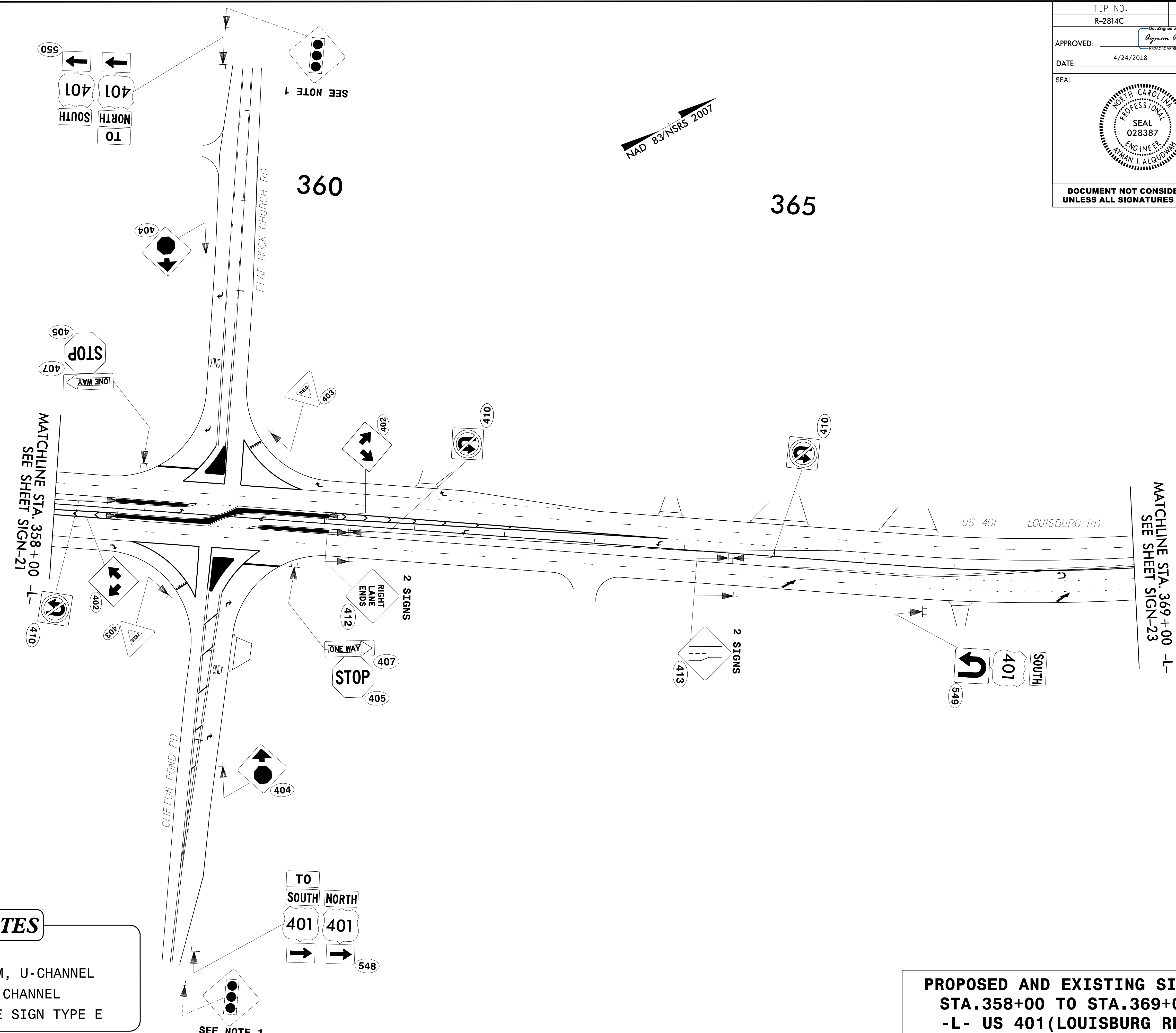

PROJECT NOTES

1. DISPOSAL OF SIGN SYSTEM, U-CHANNEL
2. DISPOSAL OF SUPPORT, U-CHANNEL
3. SIGN ERECTION, RELOCATE SIGN TYPE E

**PROPOSED AND EXISTING SIGNS
STA. 358+00 TO STA. 369+00
-L- US 401 (LOUISBURG RD)**

04/24/18
 N:\TIP\Projects-R\R2814c\Traffic\Signing\CADD\Signing_Layout\Plans\R2814C_Sign-22.dgn
 Users\johns

NAD 83/NSRS 2007

370

375

380

END SIGNING PROJECT R-2814C
-L- STA. 381+40

MATCHLINE STA. 369+00 -L-
SEE SHEET SIGN-22

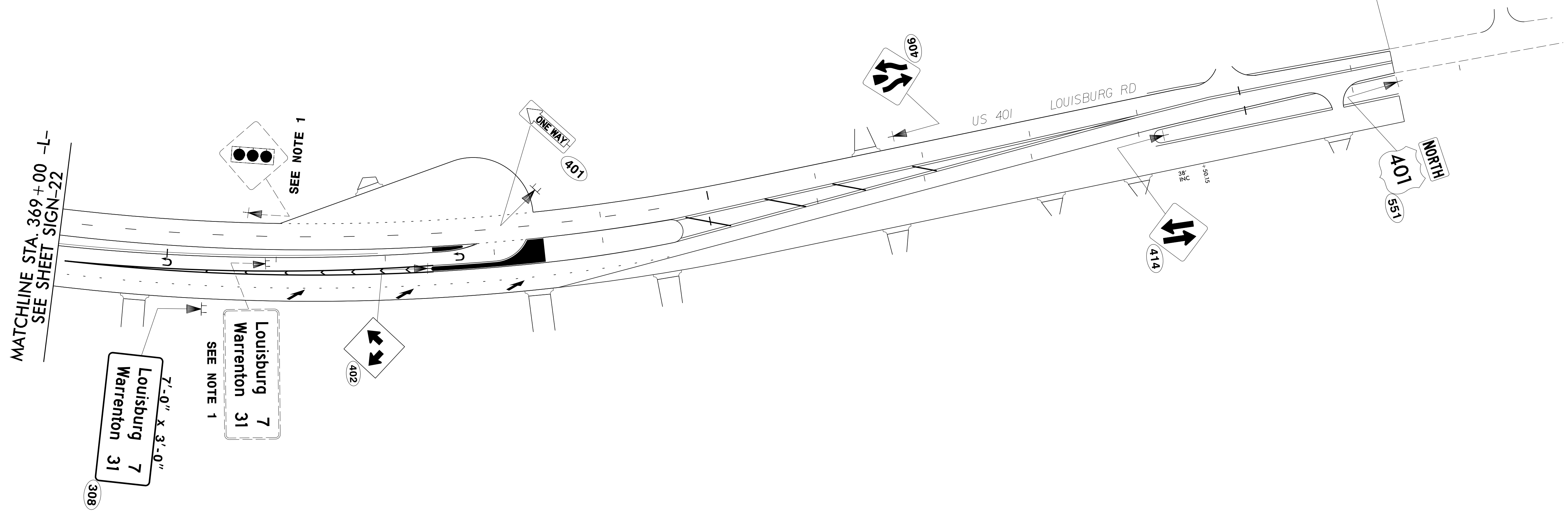

PROJECT NOTES

1. DISPOSAL OF SIGN SYSTEM, U-CHANNEL
2. DISPOSAL OF SUPPORT, U-CHANNEL
3. SIGN ERECTION, RELOCATE SIGN TYPE E

**PROPOSED AND EXISTING SIGNS
STA. 369+00 TO STA. 381+40
-L- US 401 (LOUISBURG RD)**

04/24/18
 N:\TIP\Projects-R\R2814c\Traffic\Signing\CADD\Signing\Layout\Plans\R2814C_Sign-23.dgn
 Users\johnh