

**This electronic collection of documents is provided
for the convenience of the user
and is Not a Certified Document –**

**The documents contained herein were originally issued
and sealed by the individuals whose names and license
numbers appear on each page, on the dates appearing
with their signature on that page.**

**This file or an individual page
shall not be considered a certified document.**

TIP PROJECT: U-2412A

CONTRACT:

**STATE OF NORTH CAROLINA
DEPARTMENT OF TRANSPORTATION**

**PAVEMENT MARKING PLAN
GUILFORD COUNTY**

**LOCATION: SR 1486/SR 4121 (GREENSBORO/HIGH POINT RD) FROM PROPOSED
US 311 BYPASS TO WEST OF SR 1480 (VICKERY CHAPEL RD)**

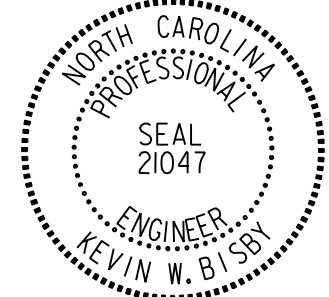
<small>PROJECT REFERENCE NO.</small> U-2412A	<small>SHEET NO.</small> PMP-1
<small>DocuSigned by:</small> <i>Kevin W. Bishop</i>	
<small>APPROVED:</small>	
<small>DATE:</small> 3/18/2018	
<small>SEAL</small>	
	
<small>DOCUMENT NOT CONSIDERED FINAL UNLESS ALL SIGNATURES COMPLETED</small>	

ROADWAY STANDARD DRAWING

THE FOLLOWING ROADWAY STANDARDS AS APPEAR IN "ROADWAY STANDARD DRAWINGS" - PROJECT SERVICES UNIT - N.C. DEPARTMENT OF TRANSPORTATION - RALEIGH, N.C., DATED JANUARY 2018 ARE APPLICABLE TO THIS PROJECT AND BY REFERENCE HEREBY ARE CONSIDERED A PART OF THESE PLANS:

<u>STD. NO.</u>	<u>TITLE</u>
1205.01	PAVEMENT MARKINGS - LINE TYPES AND OFFSETS
1205.02	PAVEMENT MARKINGS - TWO-LANE AND MULTILANE ROADWAYS
1205.04	PAVEMENT MARKINGS - INTERSECTIONS
1205.05	PAVEMENT MARKINGS - TURN LANES
1205.06	PAVEMENT MARKINGS - LANE DROPS
1205.08	PAVEMENT MARKINGS - SYMBOLS AND WORD MESSAGES
1205.09	PAVEMENT MARKINGS - PAINTED ISLANDS
1205.10	PAVEMENT MARKINGS - SCHOOL AREAS
1250.01	RAISED PAVEMENT MARKERS - INSTALLATION SPACING
1251.01	RAISED PAVEMENT MARKERS - PERMANENT AND TEMPORARY
1253.01	RAISED PAVEMENT MARKERS - SNOWPLOWABLE
1261.01	GUARDRAIL AND BARRIER DELINEATORS - INSTALLATION SPACING
1261.02	GUARDRAIL AND BARRIER DELINEATORS - TYPES AND MOUNTING
1262.01	GUARDRAIL END DELINEATION

**PAVEMENT MARKING
SCHEDULE**

THERMOPLASTIC PAVEMENT MARKING LINES

T2	WHITE STOPBAR (24", 120 MIL)
T6	WHITE EDGELINE (6", 90 MIL)
T7	YELLOW EDGELINE (6", 90 MIL)
T8	2 FT. - 6 FT./SP WHITE MINISKIP (4", 120 MIL)
T13	3 FT. - 9 FT./SP WHITE MINISKIP (8", 120 MIL)
TA	WHITE EDGELINE (4", 90 MIL)
TB	YELLOW EDGELINE (4", 90 MIL)
TC	10 FT. WHITE SKIP (4", 120 MIL)
TD	3 FT. - 9 FT./SP WHITE MINISKIP (4", 120 MIL)
TE	WHITE SOLID LANE LINE (4", 120 MIL)
TF	10 FT. YELLOW SKIP (4", 120 MIL)
TH	YELLOW SINGLE CENTER (4", 120 MIL)
TI	YELLOW DOUBLE CENTER (4", 120 MIL)
TL	WHITE SOLID LANE LINE (6", 120 MIL)
TN	WHITE GORELINE (8", 90 MIL)
TO	WHITE DIAGONAL (8", 90 MIL)
TP	YELLOW DIAGONAL (8", 90 MIL)
TR	WHITE SOLID LANE LINE (8", 120 MIL)
TU	WHITE DIAGONAL (12", 90 MIL)

THERMOPLASTIC PAVEMENT MARKING SYMBOLS

UA	LEFT TURN ARROW (90 MIL)
UB	RIGHT TURN ARROW (90 MIL)
UC	STRAIGHT ARROW (90 MIL)
UD	COMBO. LEFT/STRAIGHT ARROW (90 MIL)
UE	COMBO. RIGHT/STRAIGHT ARROW (90 MIL)
UI	ALPHANUMERIC CHAR. (120 MIL)
UN	24" YIELD LINE TRIANGLE (90 MIL)
UT	U-TURN ARROW (90 MIL)

POLYUREA PAVEMENT MARKING LINES

VA	WHITE EDGELINE (4", 20 MIL)
VB	YELLOW EDGELINE (4", 20 MIL)
VC	10 FT. WHITE SKIP (4", 20 MIL)

PAVEMENT MARKERS

MA	PERMANENT RAISED MARKER	Yellow & Yellow
MB	PERMANENT RAISED MARKER	Crystal & Red
MF	SNOWPLOWABLE MARKER	Crystal & Red

GENERAL NOTES

THE FOLLOWING GENERAL NOTES APPLY AT ALL TIMES FOR THE DURATION OF THE CONSTRUCTION PROJECT, EXCEPT WHEN OTHERWISE NOTED IN THE PLAN, OR DIRECTED BY THE ENGINEER.

- A) INSTALL PAVEMENT MARKINGS AND PAVEMENT MARKERS ON THE FINAL SURFACE AS FOLLOWS:

ROAD NAME	MARKING	MARKER
-L-	THERMOPLASTIC	SNOWPLOWABLE
-Y- LINES	THERMOPLASTIC	PERMANENT RAISED
BRIDGE DECKS	POLYUREA WITH HIGHLY REFLECTIVE MEDIA	PERMANENT RAISED

- B) TIE PROPOSED PAVEMENT MARKING LINES TO EXISTING PAVEMENT MARKING LINES.
- C) REMOVE/REPLACE ANY CONFLICTING/DAMAGED PAVEMENT MARKINGS AND MARKERS.
- D) STOP BAR LOCATION AT NON-SIGNALIZED INTERSECTIONS MAY BE ADJUSTED AS DIRECTED BY THE ENGINEER.
- E) REMOVE ALL RESIDUE AND SURFACE LAITANCE BY ACCEPTABLE METHODS ON CONCRETE BRIDGE DECKS PRIOR TO PLACING POLYUREA PAVEMENT MARKING MATERIAL.
- F) UNLESS OTHERWISE SPECIFIED, HEATED-IN-PLACE THERMOPLASTIC MAY BE USED IN LIEU OF EXTRUDED THERMOPLASTIC FOR STOP BARS, SYMBOLS, CHARACTERS AND DIAGONALS. IF HEATED-IN-PLACE IS USED, IT SHALL BE PAID FOR USING THE EXTRUDED THERMOPLASTIC PAY ITEM.
- G) TYPE III COLD APPLIED PLASTIC MAY BE USED IN LIEU OF TYPE II COLD APPLIED PLASTIC. IF TYPE III COLD APPLIED PLASTIC IS USED, IT SHALL BE PAID FOR USING THE TYPE II COLD APPLIED PLASTIC PAY ITEM.

INDEX

<u>SHEET NO.</u>	<u>DESCRIPTION</u>
PMP-1	PAVEMENT MARKING PLAN TITLE
PMP-2 THROUGH 26	PAVEMENT MARKING PLAN DETAILS

PLAN PREPARED FOR: N.C.D.O.T. SIGNING AND DELINEATION UNIT

K. L. JORDAN _____ SIGNING & DELINEATION REGIONAL ENGINEER
D. H. BEARD _____ SIGNING & DELINEATION PROJECT DESIGN ENGINEER

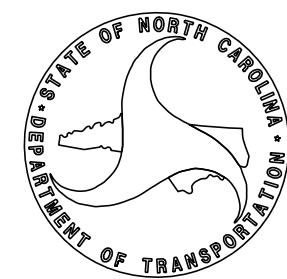

PLANS PREPARED BY :

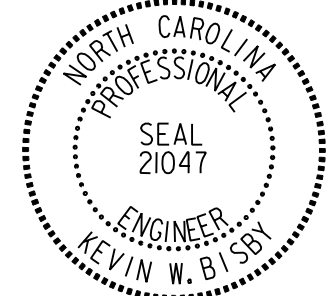

RUMMEL, KLEPPER & KAHL, LLP
900 RIDGEFIELD DRIVE SUITE 350
RALEIGH, NORTH CAROLINA 27609-3960
NC LICENSE NO. F-0112 • (919) 878-9560

PROJECT REFERENCE NO. U-2412A	SHEET NO. PMP-2
APPROVED: <i>Erwin W. Bisky</i> 3CE3C9ABDF4681	
DATE: 3/18/2018	
SEAL 	
DOCUMENT NOT CONSIDERED FINAL UNLESS ALL SIGNATURES COMPLETED	

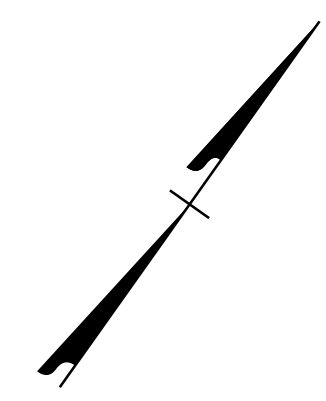
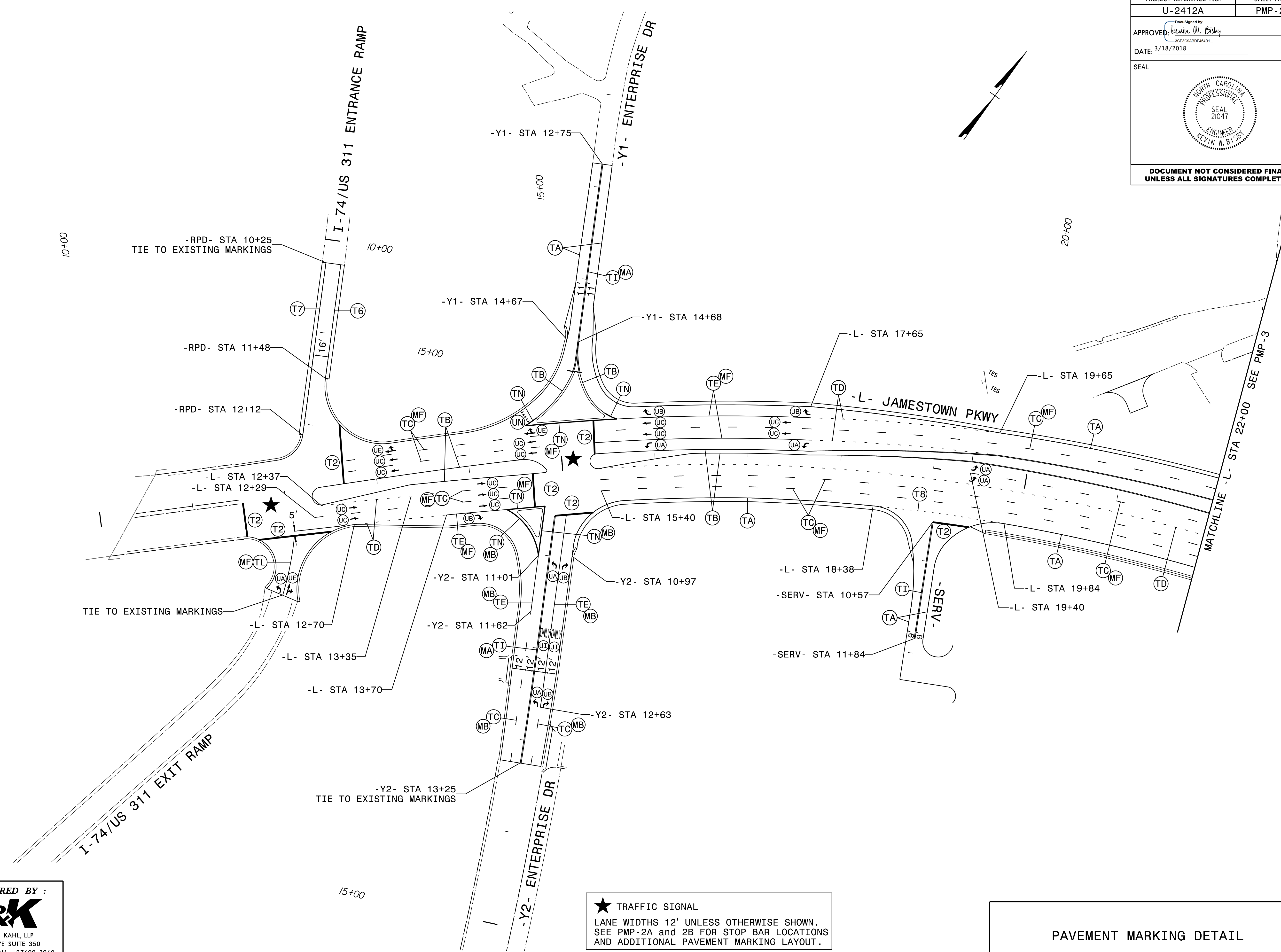

PLANS PREPARED BY :



RK&K

RUMMEL, KLEPPER & KAHL, LLP
 900 RIDGEFIELD DRIVE SUITE 350
 RALEIGH, NORTH CAROLINA 27609-3940
 NC LICENSE NO. F-0112 • (919) 878-9560

★ TRAFFIC SIGNAL
 LANE WIDTHS 12' UNLESS OTHERWISE SHOWN.
 SEE PMP-2A and 2B FOR STOP BAR LOCATIONS
 AND ADDITIONAL PAVEMENT MARKING LAYOUT.

PAVEMENT MARKING DETAIL

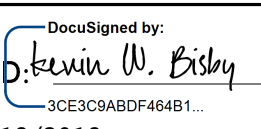
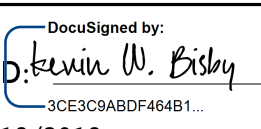
3/18/2018 PMP_PSH02.dgn

PROJECT REFERENCE NO. U-2412A	SHEET NO. PMP-2B
APPROVED:  DESIGNED BY:  DATE: 3/18/2018	
SEAL 	
DOCUMENT NOT CONSIDERED FINAL UNLESS ALL SIGNATURES COMPLETED	

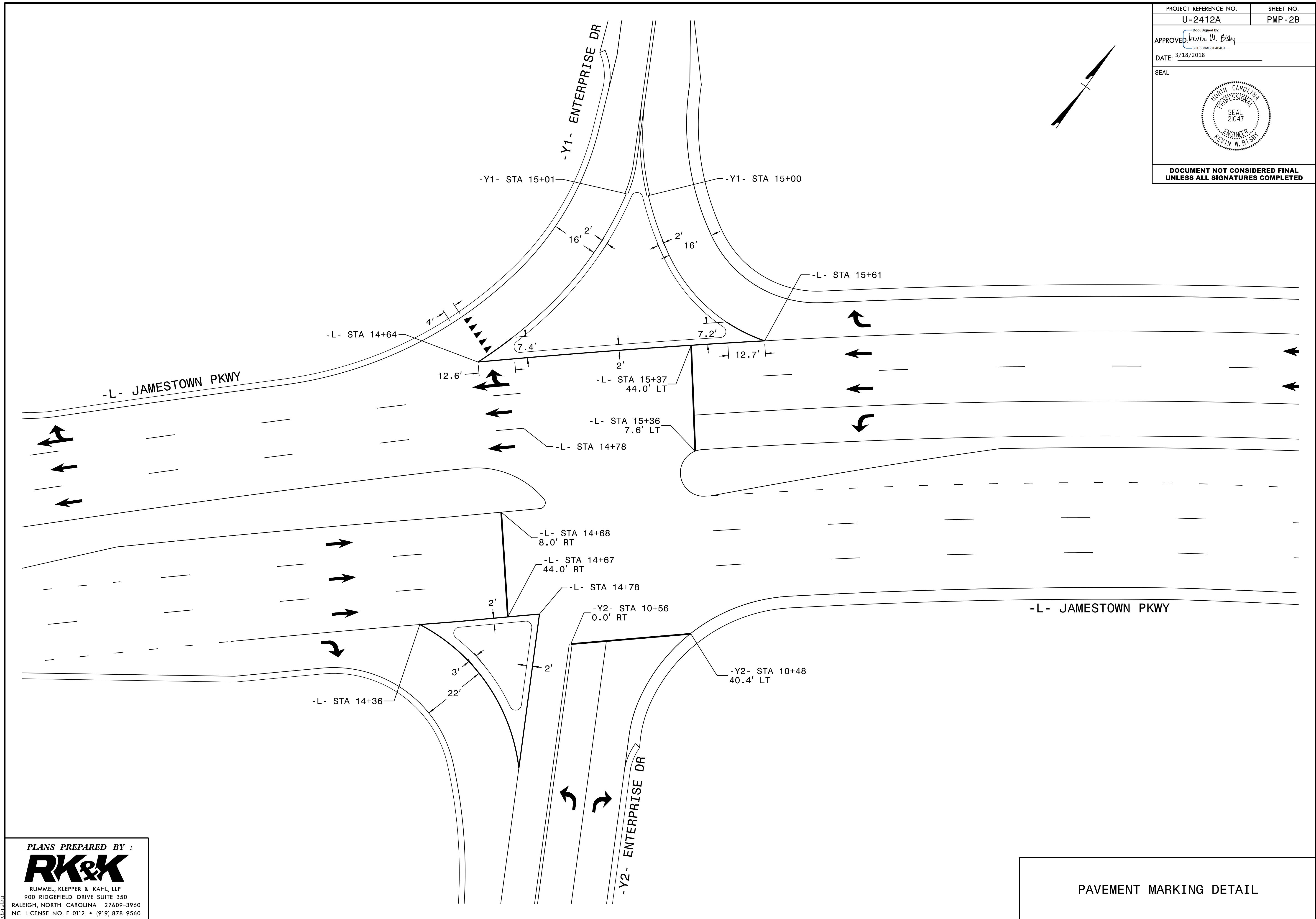
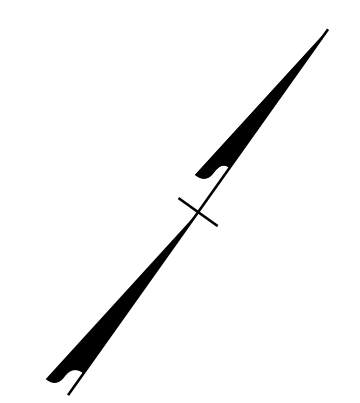

3/18/2018 12:50 PM PMP_PSH02B.dgn
K. Bisky

PLANS PREPARED BY :



RUMMEL, KLEPPER & KAHL, LLP
900 RIDGEFIELD DRIVE SUITE 350
RALEIGH, NORTH CAROLINA 27609-3960
NC LICENSE NO. F-0112 • (919) 878-9560

PAVEMENT MARKING DETAIL

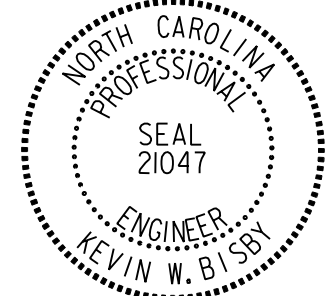
PROJECT REFERENCE NO. U-2412A	SHEET NO. PMP-3
APPROVED: <i>Kevin W. Esby</i> <small>3CE3C9A8DF464B1</small>	
DATE: 3/18/2018	
SEAL 	
DOCUMENT NOT CONSIDERED FINAL UNLESS ALL SIGNATURES COMPLETED	

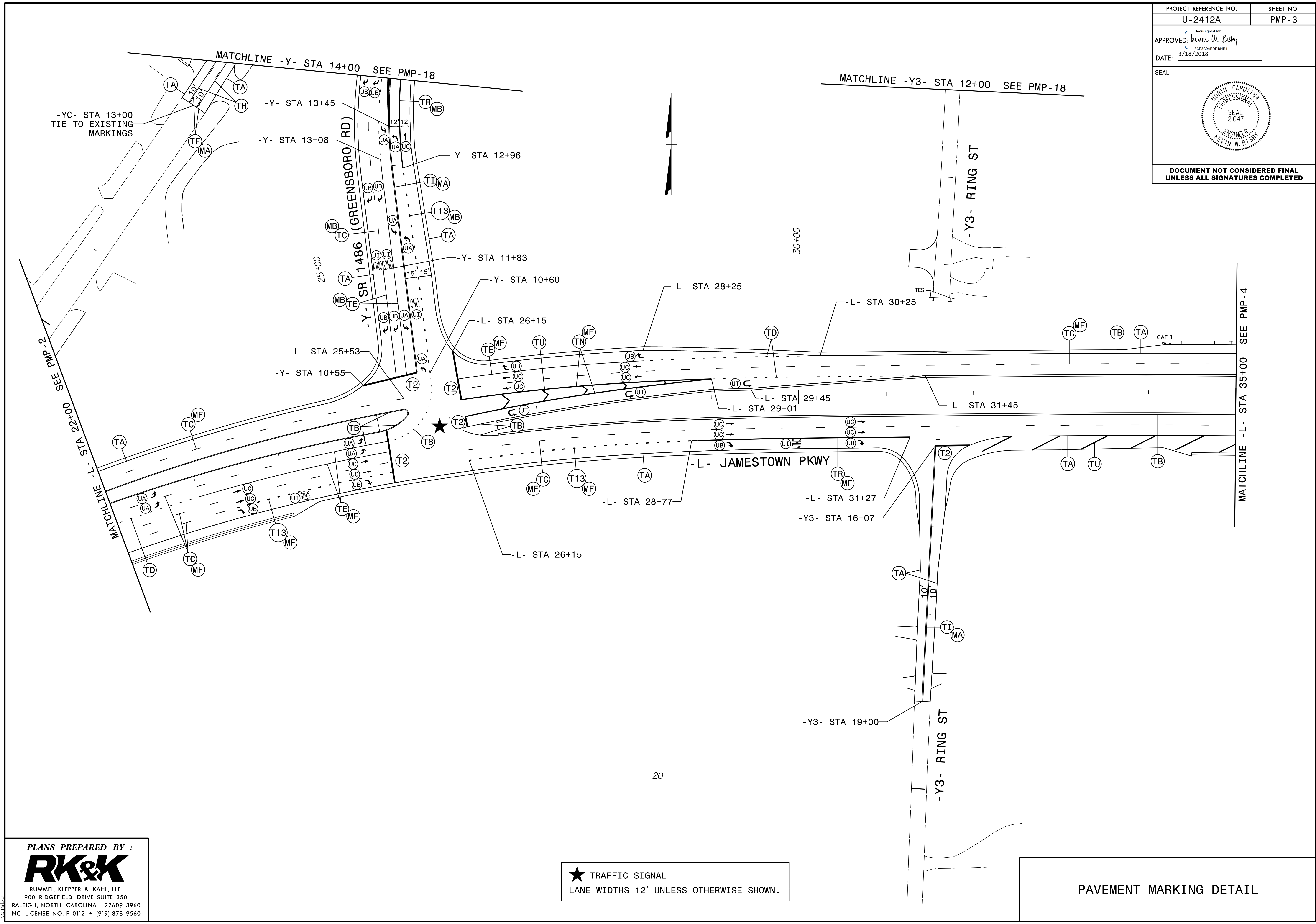

PLANS PREPARED BY :





RUMMEL, KLEPPER & KAHL, LLP
900 RIDGEFIELD DRIVE SUITE 350
RALEIGH, NORTH CAROLINA 27609-3940
NC LICENSE NO. F-0112 • (919) 878-9560

★ TRAFFIC SIGNAL
LANE WIDTHS 12' UNLESS OTHERWISE SHOWN.

PAVEMENT MARKING DETAIL

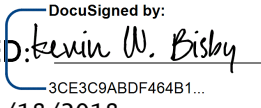
3/18/2018 PMP_PSH03.dgn

PROJECT REFERENCE NO.	SHEET NO.
U-2412A	PMP-4
APPROVED:  DocuSigned by: Kevin W. Esby 3CE3CBADF4861	
DATE: 3/18/2018	
SEAL	
	
DOCUMENT NOT CONSIDERED FINAL UNLESS ALL SIGNATURES COMPLETED	

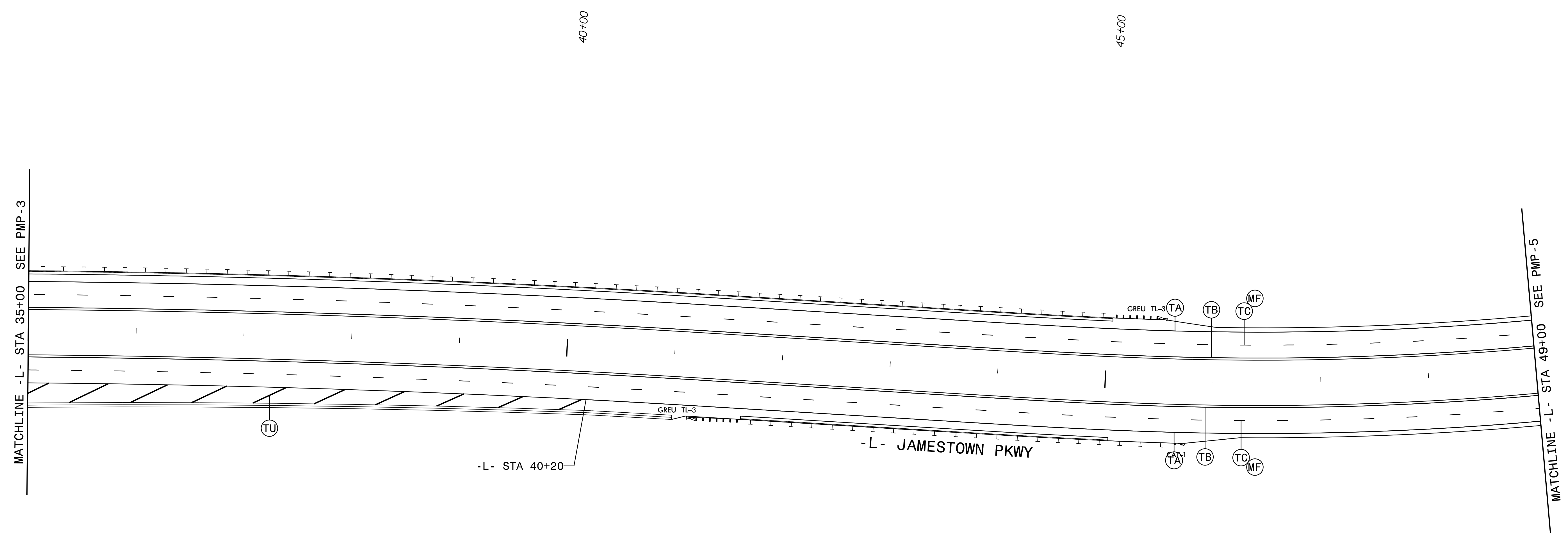

3/18/2018 PMP_PSH04.dgn

PLANS PREPARED BY :

RK&K

RUMMEL, KLEPPER & KAHL, LLP
 900 RIDGEFIELD DRIVE SUITE 350
 RALEIGH, NORTH CAROLINA 27609-3960
 NC LICENSE NO. F-0112 • (919) 878-9560

LANE WIDTHS 12' UNLESS OTHERWISE SHOWN.

PAVEMENT MARKING DETAIL

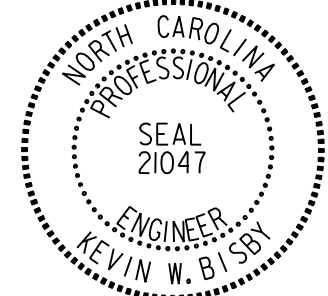
PROJECT REFERENCE NO. U-2412A	SHEET NO. PMP-5
APPROVED: <i>Kevin W. Esby</i> <small>DocuSigned by: Kevin W. Esby 3CE3C8ABDF464B1</small>	
DATE: 3/18/2018	
SEAL 	
DOCUMENT NOT CONSIDERED FINAL UNLESS ALL SIGNATURES COMPLETED	

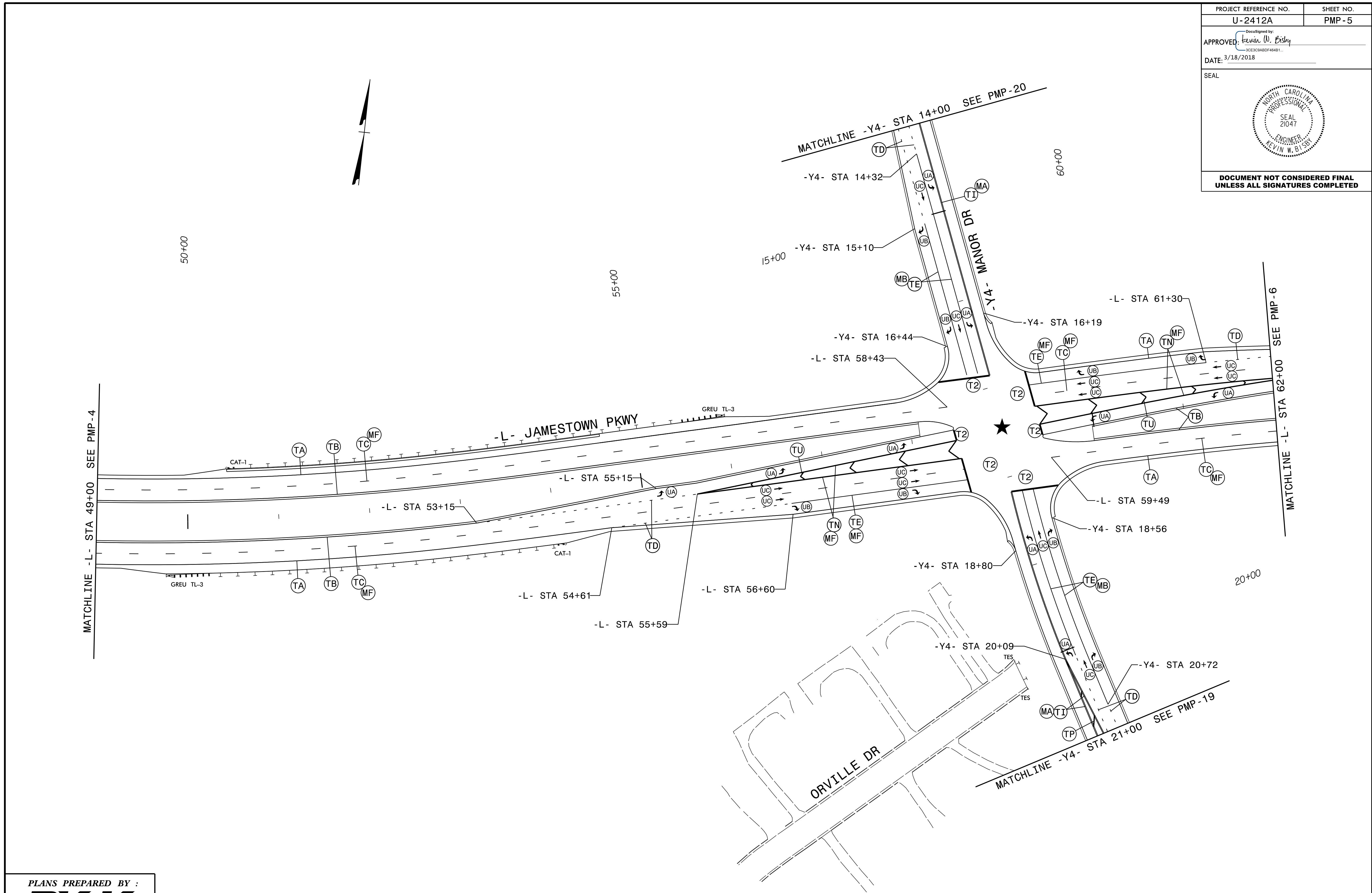

PLANS PREPARED BY :



RUMMEL, KLEPPER & KAHL, LLP
900 RIDGEFIELD DRIVE SUITE 350
RALEIGH, NORTH CAROLINA 27609-3960
NC LICENSE NO. F-0112 • (919) 878-9560

★ TRAFFIC SIGNAL
LANE WIDTHS 12' UNLESS OTHERWISE SHOWN.
SEE PMP-5A FOR STOP BAR LOCATIONS.

PAVEMENT MARKING DETAIL

3/18/2018 10:20 AM PMP_PSH05.dgn

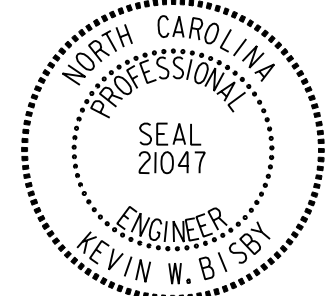
PROJECT REFERENCE NO. U-2412A	SHEET NO. PMP-5A
APPROVED: <i>Kevin W. Esley</i> 3CE3C8ABDF4481	
DATE: 3/18/2018	
SEAL 	
DOCUMENT NOT CONSIDERED FINAL UNLESS ALL SIGNATURES COMPLETED	

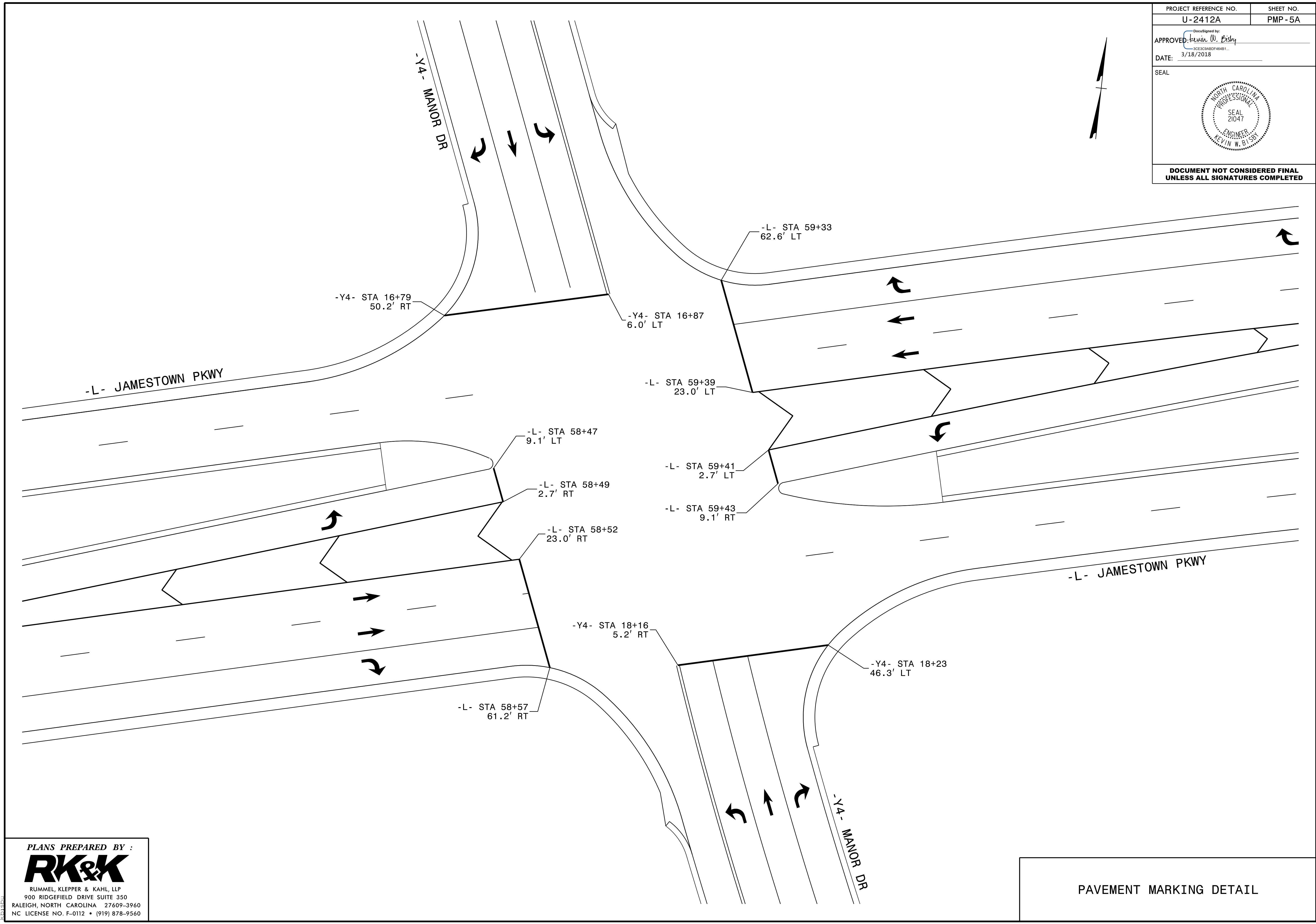
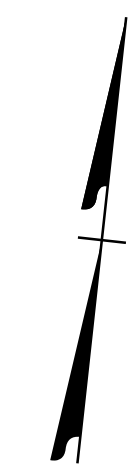

3/18/2018 12:50 PM PSH05A.dgn

PLANS PREPARED BY :



RUMMEL, KLEPPER & KAHL, LLP
900 RIDGEFIELD DRIVE SUITE 350
RALEIGH, NORTH CAROLINA 27609-3940
NC LICENSE NO. F-0112 • (919) 878-9560

PAVEMENT MARKING DETAIL

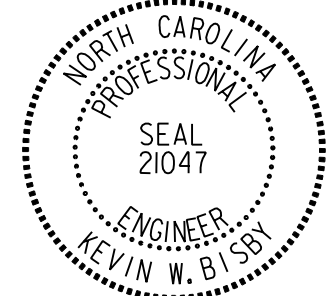
PROJECT REFERENCE NO. U-2412A	SHEET NO. PMP-6
APPROVED: <i>Kevin W. Esby</i> <small>DocuSigned by: Kevin W. Esby 3CE3C8ABDF44B1</small>	
DATE: 3/18/2018	
SEAL 	
DOCUMENT NOT CONSIDERED FINAL UNLESS ALL SIGNATURES COMPLETED	

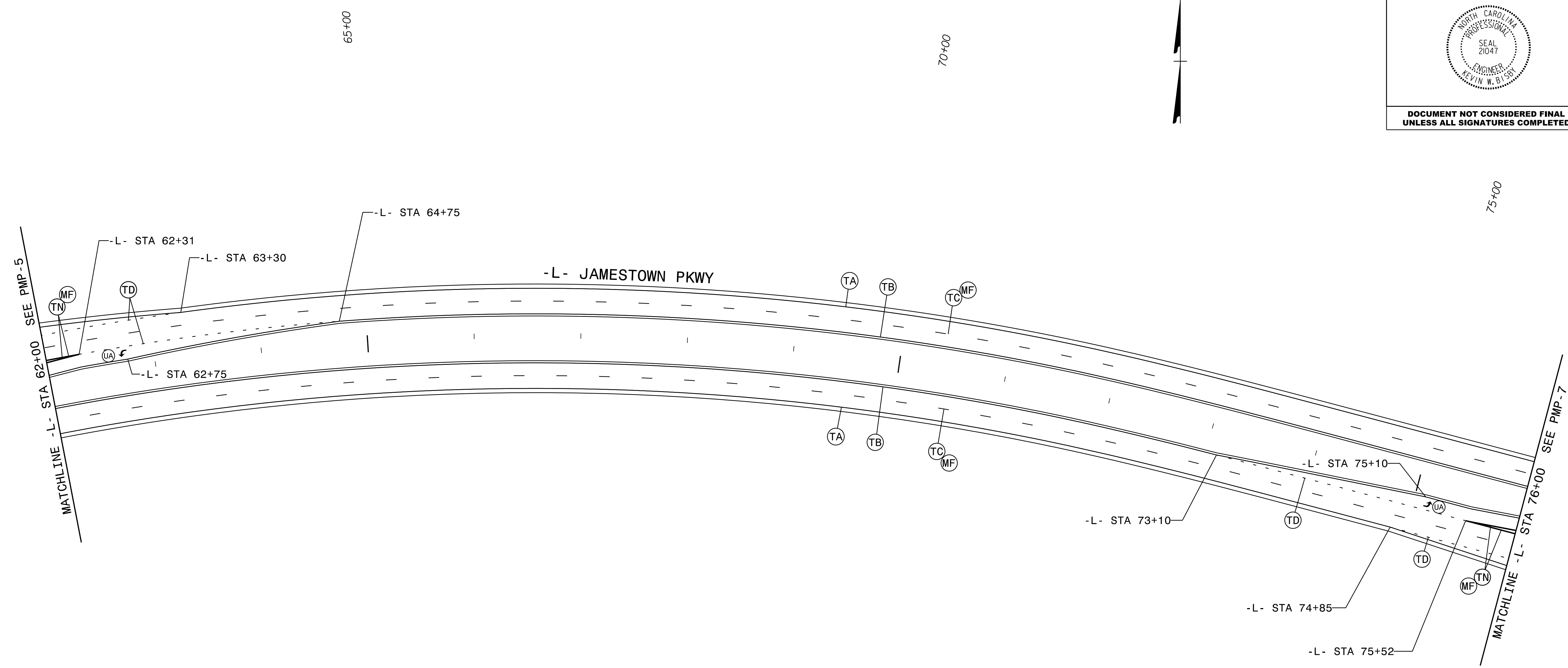

3/18/2018 12:50 PMP_PSH06.dgn
K:\11111

PLANS PREPARED BY :
RK&K
 RUMMEL, KLEPPER & KAHL, LLP
 900 RIDGEFIELD DRIVE SUITE 350
 RALEIGH, NORTH CAROLINA 27609-3960
 NC LICENSE NO. F-0112 • (919) 878-9560

PAVEMENT MARKING DETAIL

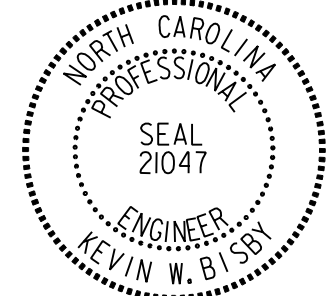
PROJECT REFERENCE NO. U-2412A	SHEET NO. PMP-7
APPROVED <i>Kevin W. Bishop</i> 3/18/2018	
DATE: 3/18/2018	
SEAL	
	
DOCUMENT NOT CONSIDERED FINAL UNLESS ALL SIGNATURES COMPLETED	

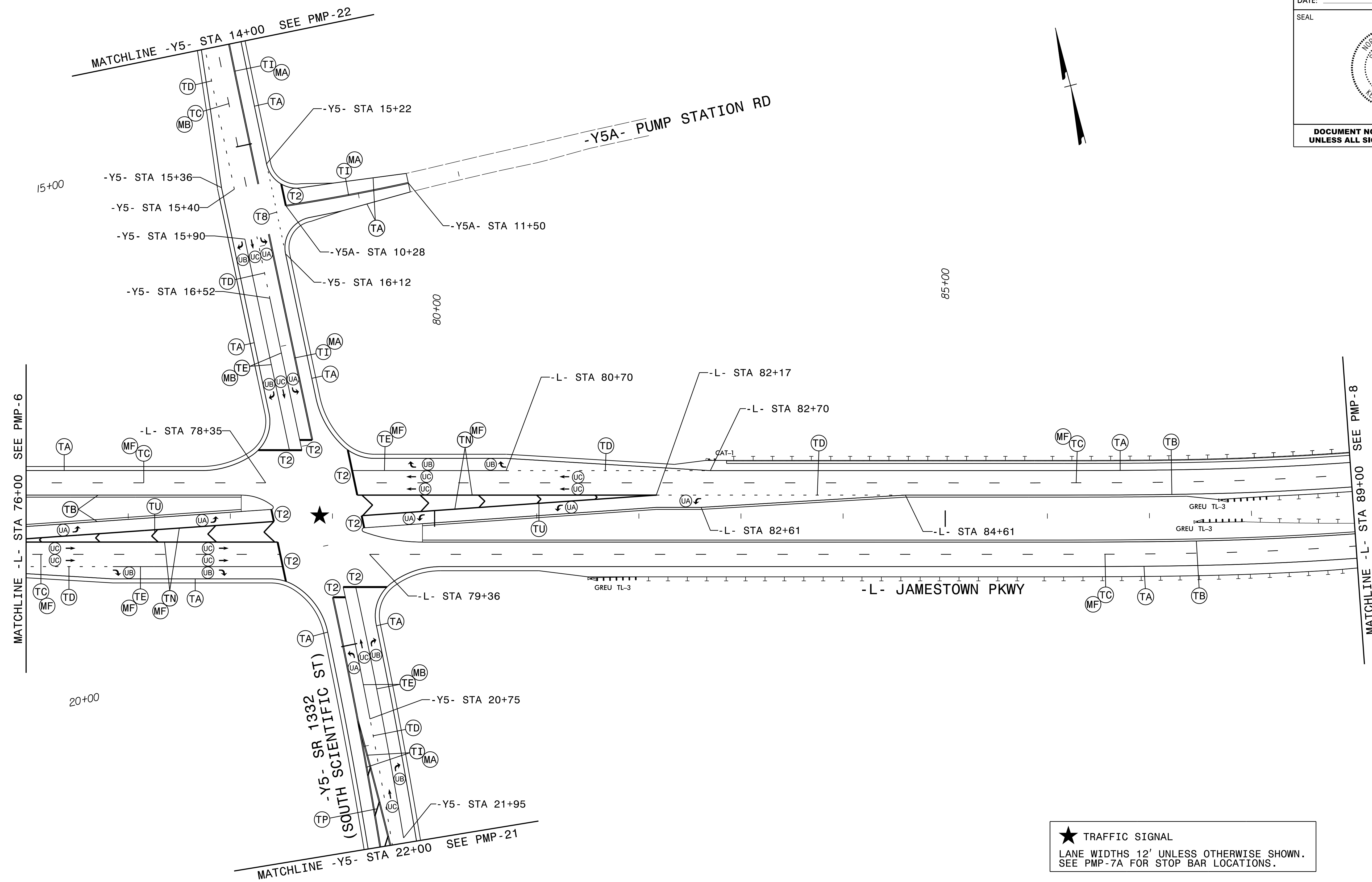

★ TRAFFIC SIGNAL
 LANE WIDTHS 12' UNLESS OTHERWISE SHOWN.
 SEE PMP-7A FOR STOP BAR LOCATIONS.

PLANS PREPARED BY :



RUMMEL, KLEPPER & KAHL, LLP
 900 RIDGEFIELD DRIVE SUITE 350
 RALEIGH, NORTH CAROLINA 27609-3960
 NC LICENSE NO. F-0112 • (919) 878-9560

PAVEMENT MARKING DETAIL

3/18/2018 PMP_PSH07.dgn

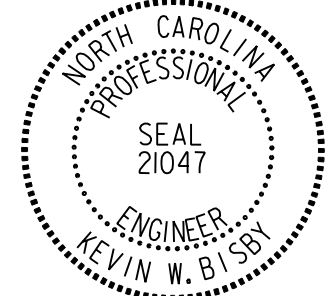
PROJECT REFERENCE NO. U-2412A	SHEET NO. PMP-7A
APPROVED: <i>Kevin W. Bisby</i> DATE: 3/18/2018	
SEAL 	
DOCUMENT NOT CONSIDERED FINAL UNLESS ALL SIGNATURES COMPLETED	

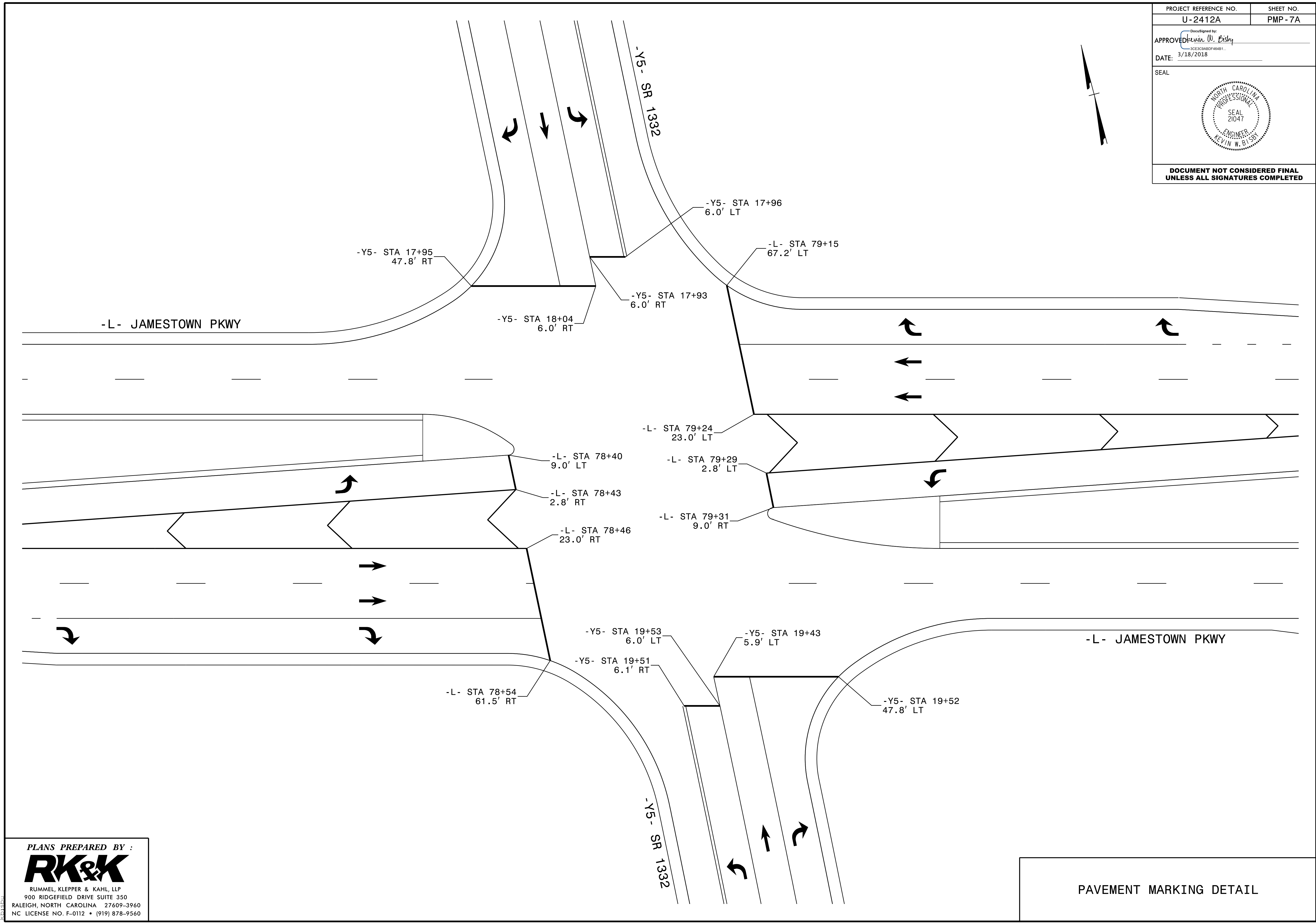

3/18/2018 12:50 PM PMP_PSH07A.dgn

PLANS PREPARED BY :



RUMMEL, KLEPPER & KAHL, LLP
900 RIDGEFIELD DRIVE SUITE 350
RALEIGH, NORTH CAROLINA 27609-3960
NC LICENSE NO. F-0112 • (919) 878-9560

PAVEMENT MARKING DETAIL

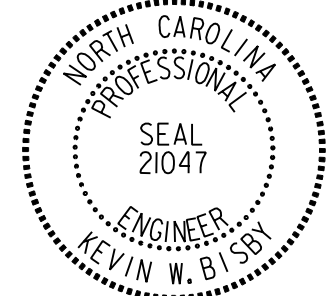
PROJECT REFERENCE NO. U-2412A	SHEET NO. PMP-8
APPROVED: <i>Kevin W. Bishop</i> 3CE3C9A8DF44B1	
DATE: 3/18/2018	
SEAL 	
DOCUMENT NOT CONSIDERED FINAL UNLESS ALL SIGNATURES COMPLETED	

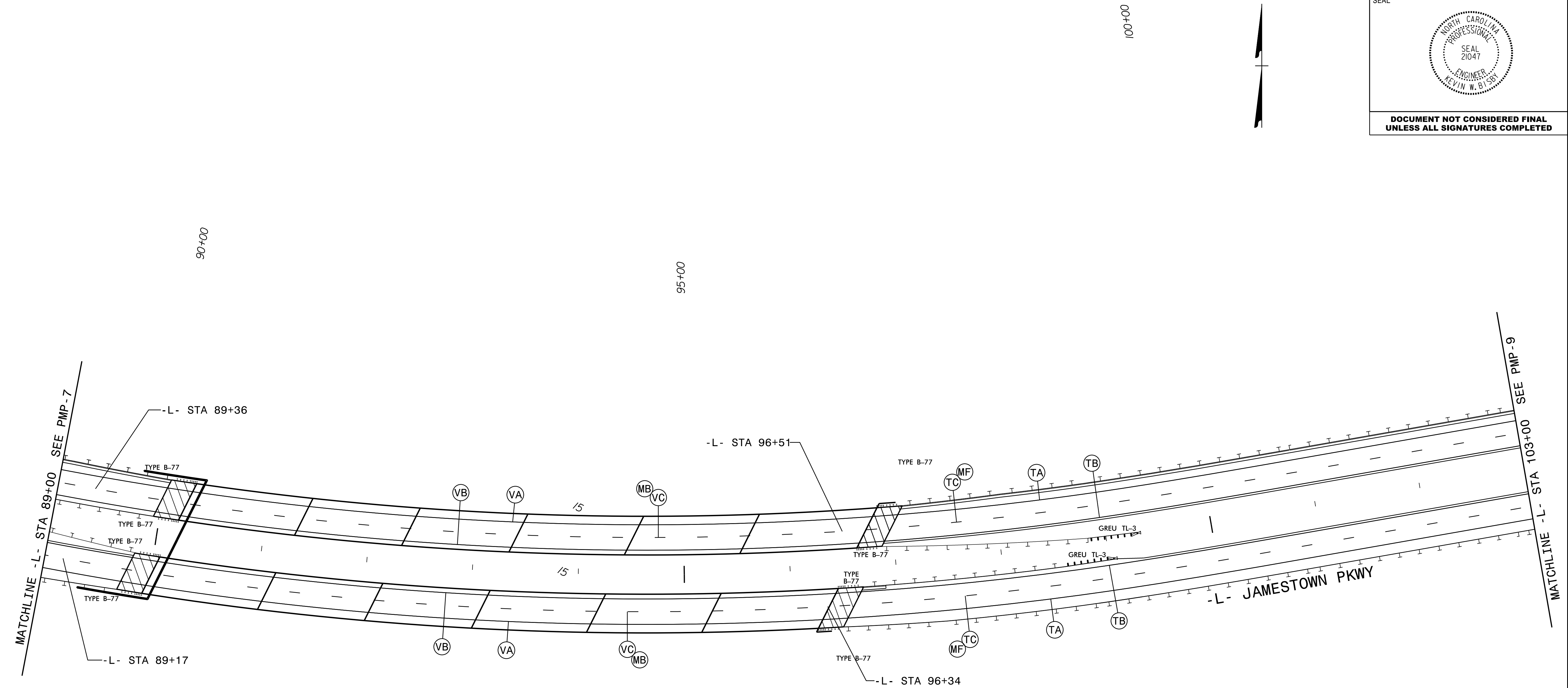

3/18/2018 PMP_PSH08.dgn

PLANS PREPARED BY :



RUMMEL, KLEPPER & KAHL, LLP
900 RIDGEFIELD DRIVE SUITE 350
RALEIGH, NORTH CAROLINA 27609-3960
NC LICENSE NO. F-0112 • (919) 878-9560

LANE WIDTHS 12' UNLESS OTHERWISE SHOWN.

PAVEMENT MARKING DETAIL

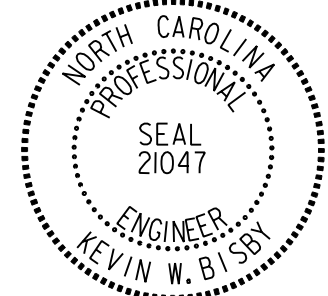
PROJECT REFERENCE NO. U-2412A	SHEET NO. PMP-9
APPROVED <i>Kevin W. Bishop</i> 3/18/2018	
DATE: 3/18/2018	
SEAL 	
DOCUMENT NOT CONSIDERED FINAL UNLESS ALL SIGNATURES COMPLETED	

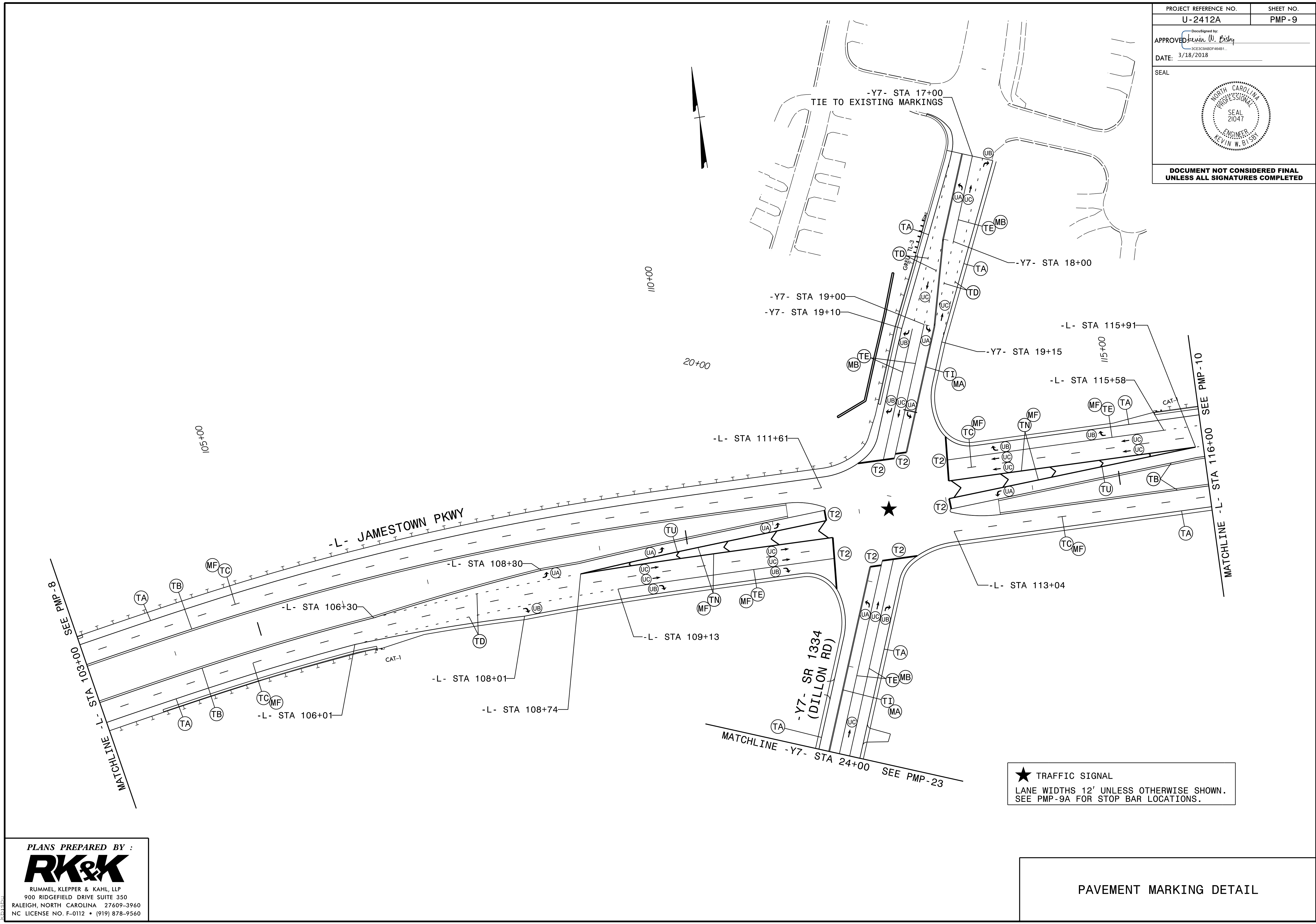

★ TRAFFIC SIGNAL
LANE WIDTHS 12' UNLESS OTHERWISE SHOWN.
SEE PMP-9A FOR STOP BAR LOCATIONS.



PLANS PREPARED BY :



RUMMEL, KLEPPER & KAHL, LLP
900 RIDGEFIELD DRIVE SUITE 350
RALEIGH, NORTH CAROLINA 27609-3960
NC LICENSE NO. F-0112 • (919) 878-9560

PAVEMENT MARKING DETAIL

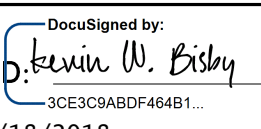
3/18/2018 PMP_PSH09.dgn

PROJECT REFERENCE NO. U-2412A	SHEET NO. PMP-9A
APPROVED:  3CE3C8AB0F481	
DATE: 3/18/2018	
SEAL 	
DOCUMENT NOT CONSIDERED FINAL UNLESS ALL SIGNATURES COMPLETED	

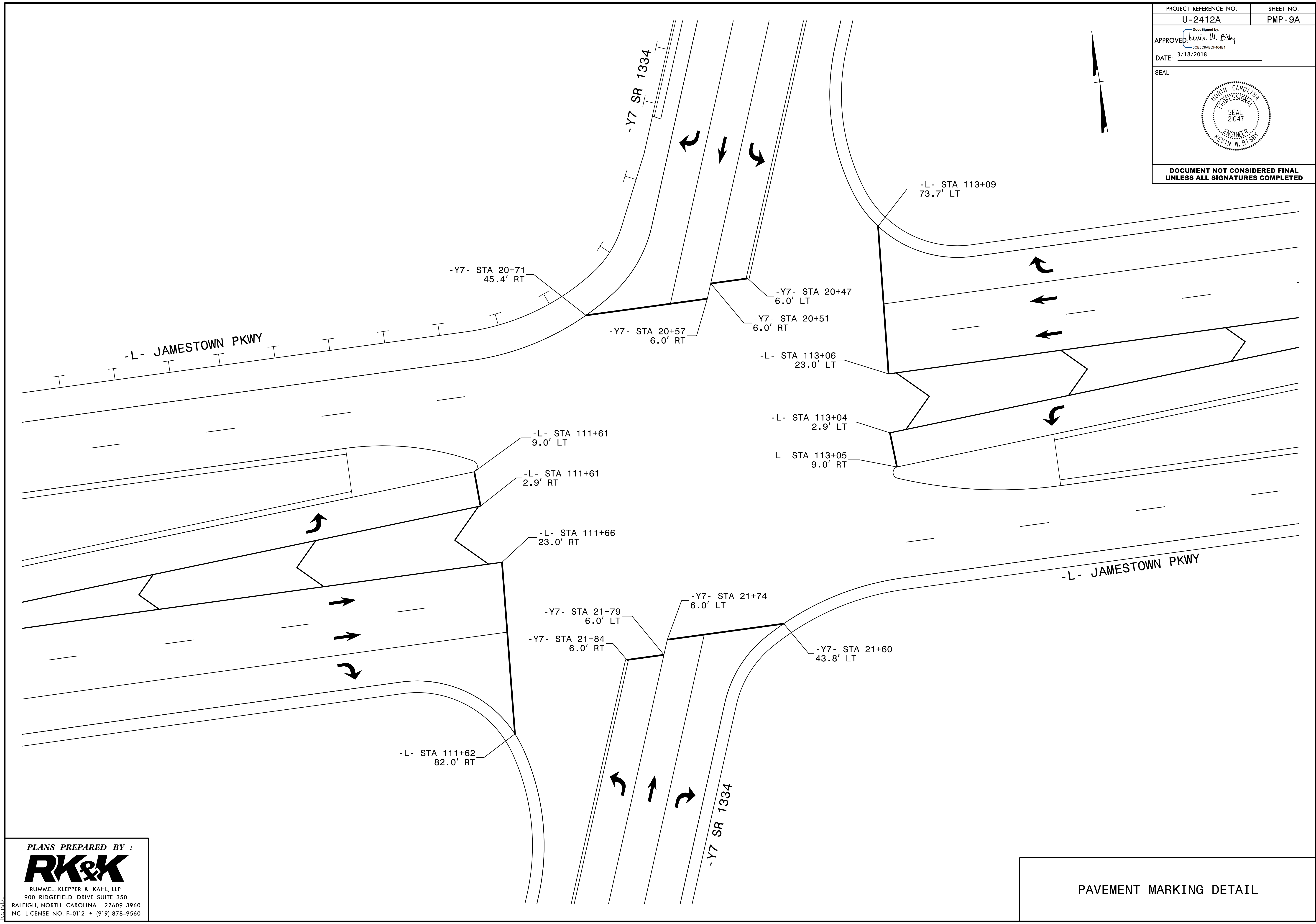

PLANS PREPARED BY :



RUMMEL, KLEPPER & KAHL, LLP
900 RIDGEFIELD DRIVE SUITE 350
RALEIGH, NORTH CAROLINA 27609-3960
NC LICENSE NO. F-0112 • (919) 878-9560

PAVEMENT MARKING DETAIL

3/18/2018 10:50 AM P:\SH09A.dgn

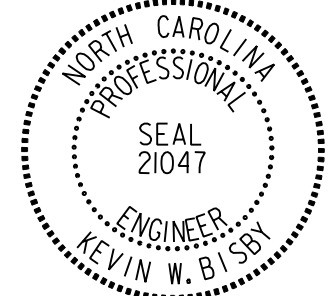
PROJECT REFERENCE NO. U-2412A	SHEET NO. PMP-10
APPROVED: <i>Kevin W. Bisy</i> <small>DocuSigned by: 3CE3C9ABDF46481</small>	
DATE: 3/18/2018	
SEAL 	
DOCUMENT NOT CONSIDERED FINAL UNLESS ALL SIGNATURES COMPLETED	

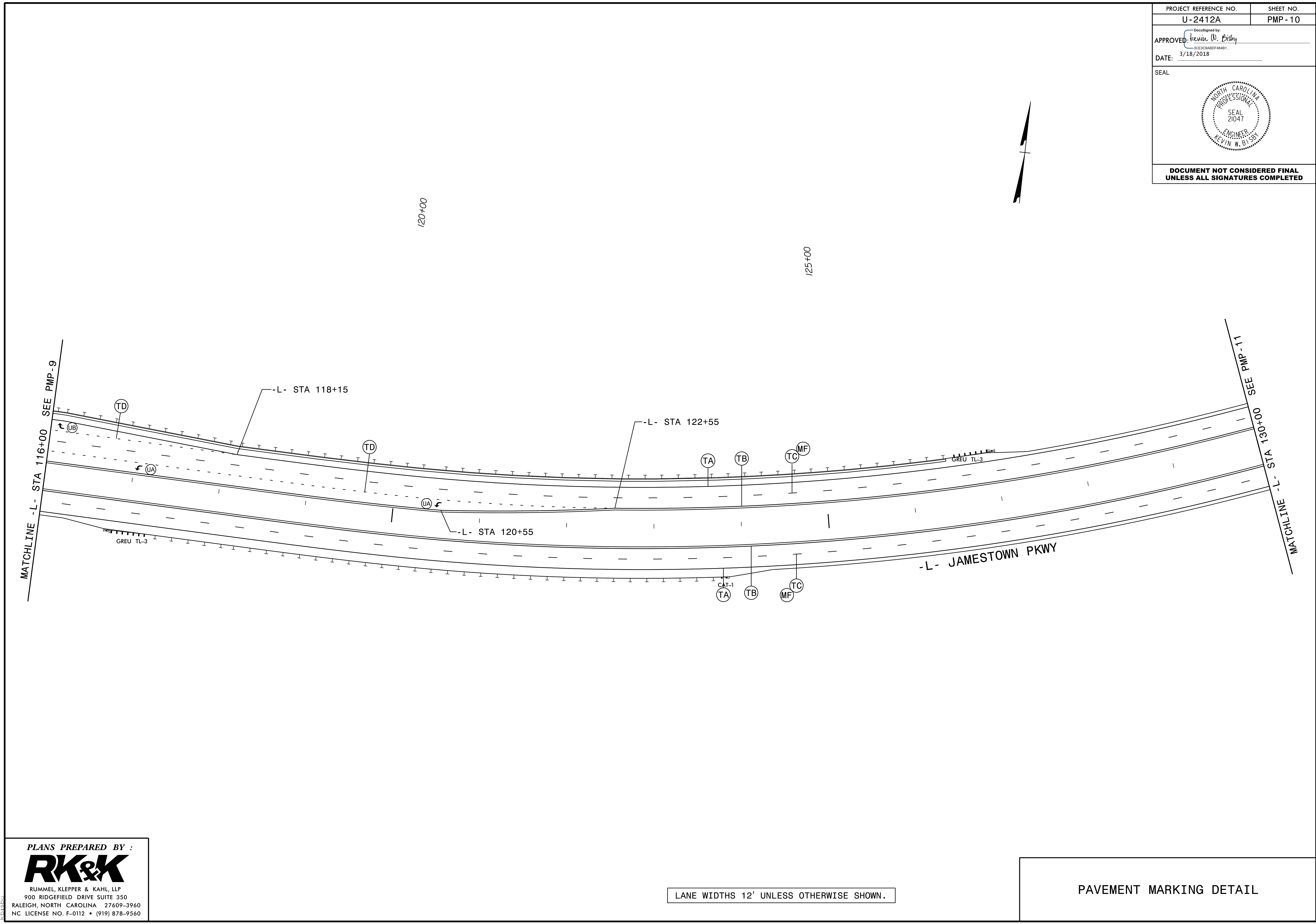

3/18/2018 PMP_PSH10.dgn

PLANS PREPARED BY :



RUMMEL, KLEPPER & KAHL, LLP
900 RIDGEFIELD DRIVE SUITE 350
RALEIGH, NORTH CAROLINA 27609-3960
NC LICENSE NO. F-0112 • (919) 878-9560

LANE WIDTHS 12' UNLESS OTHERWISE SHOWN.

PAVEMENT MARKING DETAIL

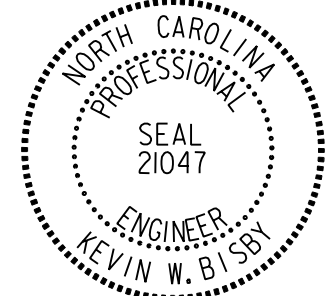
PROJECT REFERENCE NO. U-2412A	SHEET NO. PMP-11
APPROVED: <i>Kevin W. Bishop</i> 3/18/2018	
DATE: 3/18/2018	
SEAL	
	
DOCUMENT NOT CONSIDERED FINAL UNLESS ALL SIGNATURES COMPLETED	

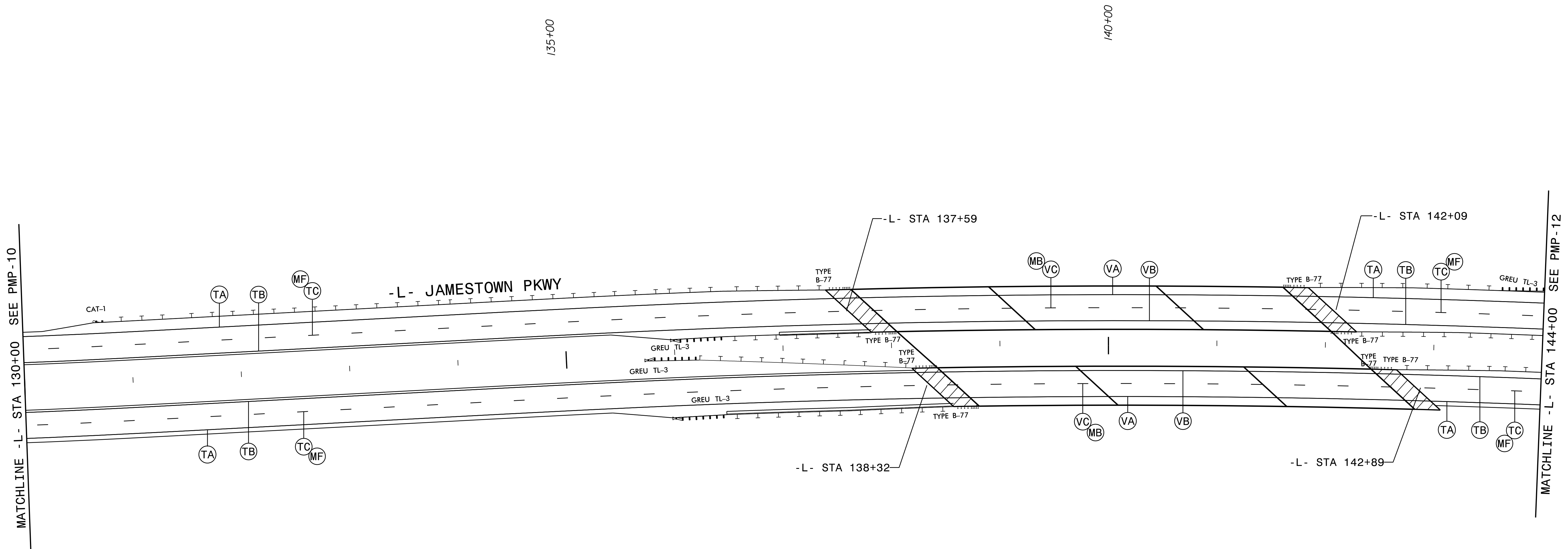
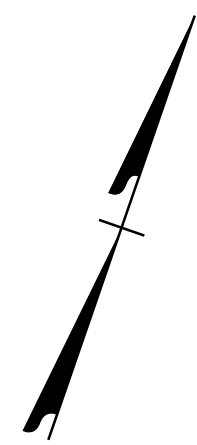

PLANS PREPARED BY :
RK&K
 RUMMEL, KLEPPER & KAHL, LLP
 900 RIDGEFIELD DRIVE SUITE 350
 RALEIGH, NORTH CAROLINA 27609-3960
 NC LICENSE NO. F-0112 • (919) 878-9560

LANE WIDTHS 12' UNLESS OTHERWISE SHOWN.

PAVEMENT MARKING DETAIL

3/18/2018 PMP_PSH11.dgn

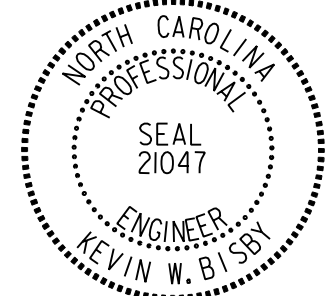
PROJECT REFERENCE NO. U-2412A	SHEET NO. PMP-12
APPROVED: <i>Kevin W. Biskay</i> 3CE3C9ABDF4861	
DATE: 3/18/2018	
SEAL 	
DOCUMENT NOT CONSIDERED FINAL UNLESS ALL SIGNATURES COMPLETED	

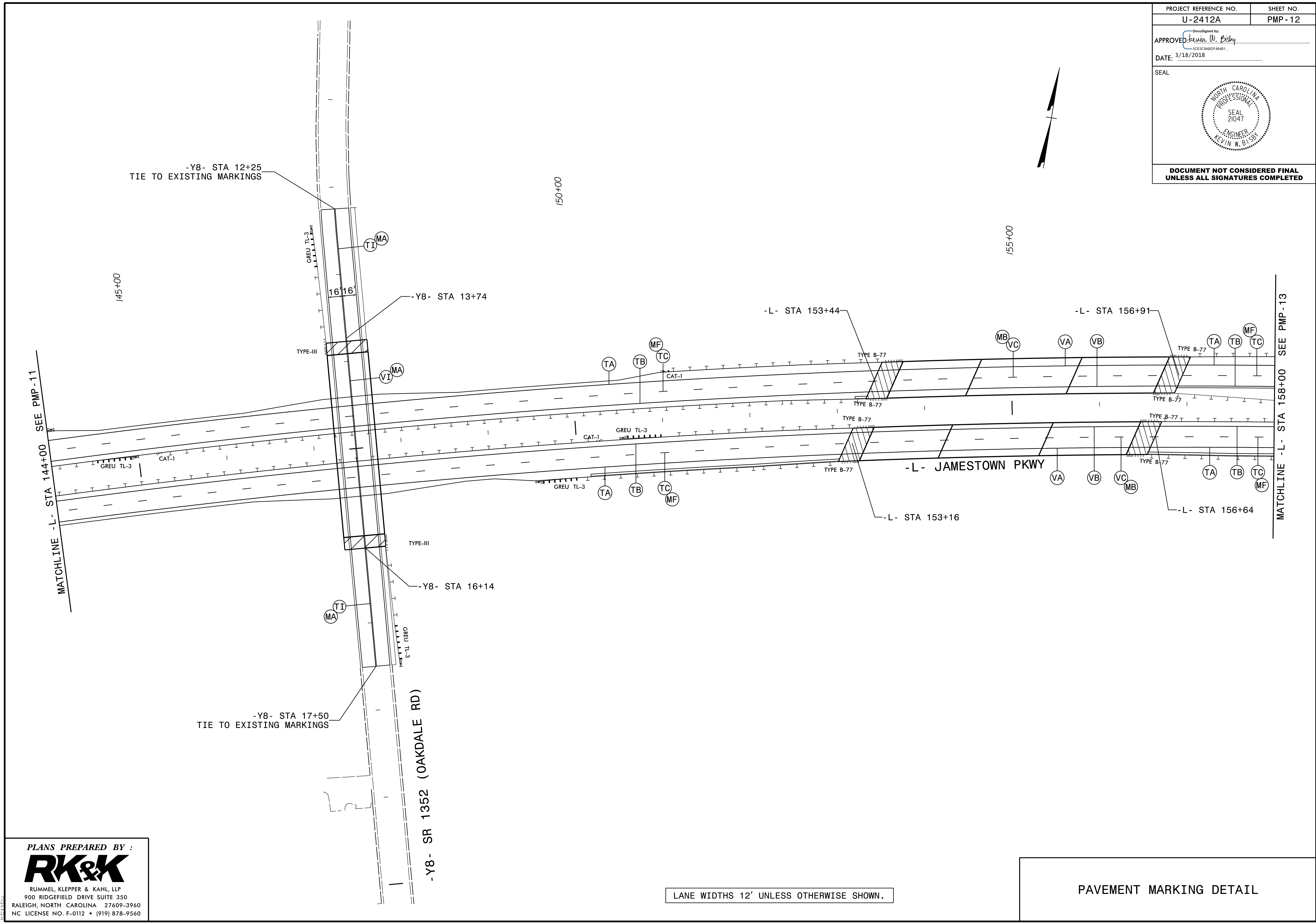

PLANS PREPARED BY :

 RUMMEL, KLEPPER & KAHL, LLP
 900 RIDGEFIELD DRIVE SUITE 350
 RALEIGH, NORTH CAROLINA 27609-3960
 NC LICENSE NO. F-0112 • (919) 878-9560

LANE WIDTHS 12' UNLESS OTHERWISE SHOWN.

PAVEMENT MARKING DETAIL

3/18/2018 PMP_PSH12.dgn

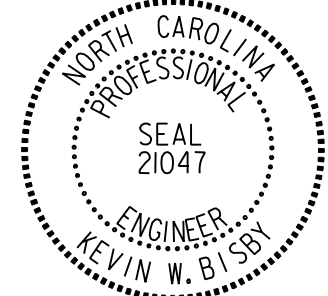
PROJECT REFERENCE NO. U-2412A	SHEET NO. PMP-13
APPROVED: <i>Kevin W. Esley</i> 3/18/2018	
DATE: 3/18/2018	
SEAL 	
DOCUMENT NOT CONSIDERED FINAL UNLESS ALL SIGNATURES COMPLETED	

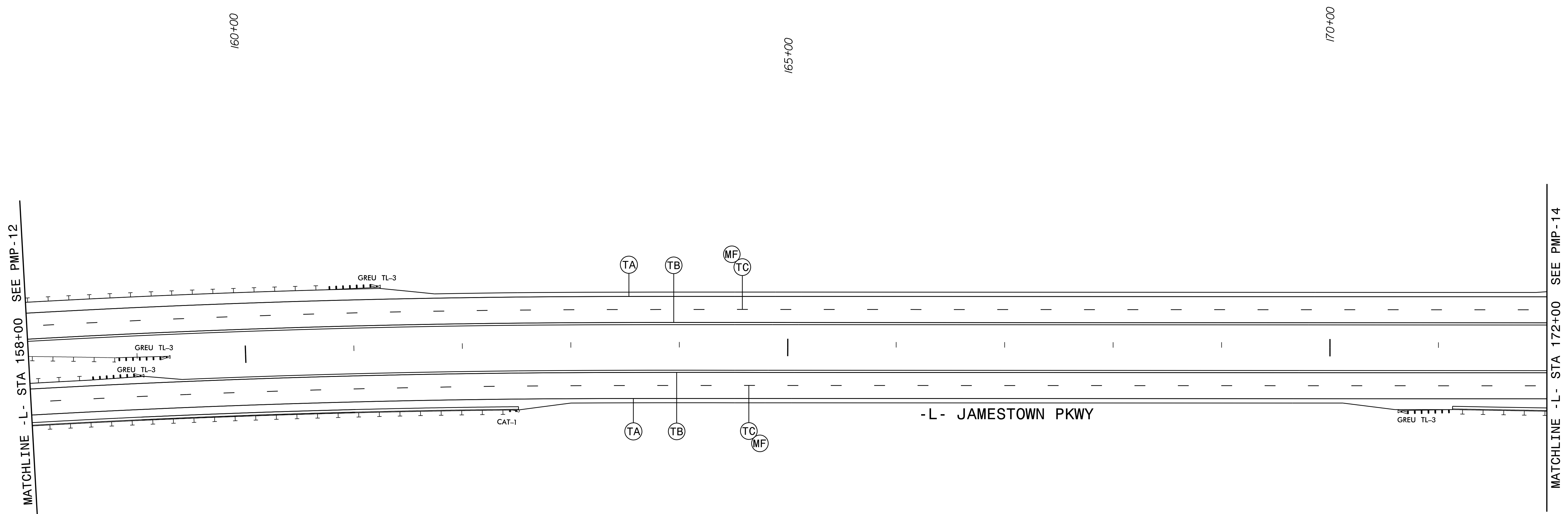
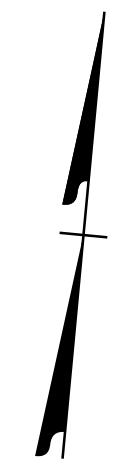

3/18/2018 PMP.PSH13.dgn
12:41:20
K&K

PLANS PREPARED BY :

RK&K

RUMMEL, KLEPPER & KAHL, LLP
900 RIDGEFIELD DRIVE SUITE 350
RALEIGH, NORTH CAROLINA 27609-3960
NC LICENSE NO. F-0112 • (919) 878-9560

LANE WIDTHS 12' UNLESS OTHERWISE SHOWN.

PAVEMENT MARKING DETAIL

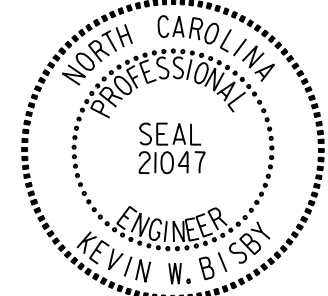
PROJECT REFERENCE NO. U-2412A	SHEET NO. PMP-14A
APPROVED: <i>Kevin W. Bishop</i> <small>DocuSigned by: Kevin W. Bishop 3CE3C9ABDF464B1</small>	
DATE: 3/18/2018	
SEAL 	
DOCUMENT NOT CONSIDERED FINAL UNLESS ALL SIGNATURES COMPLETED	

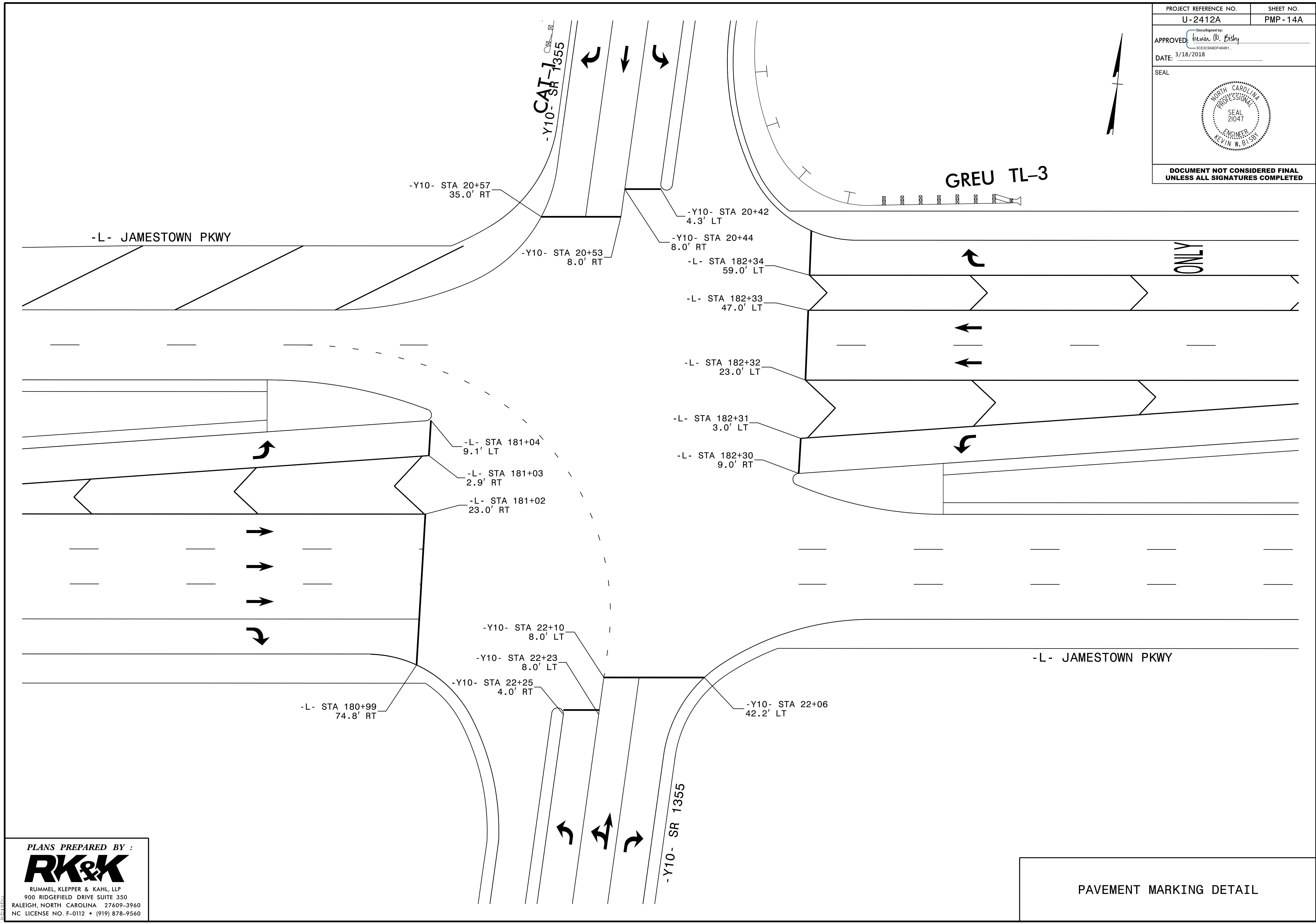



3/18/2018 10:20 AM PMP_PSH14A.dgn

PLANS PREPARED BY :



RUMMEL, KLEPPER & KAHL, LLP
900 RIDGEFIELD DRIVE SUITE 350
RALEIGH, NORTH CAROLINA 27609-3960
NC LICENSE NO. F-0112 • (919) 878-9560

PAVEMENT MARKING DETAIL

PROJECT REFERENCE NO. U-2412A	SHEET NO. PMP-15
APPROVED:  3CE3C9A8DF464B1	
DATE: 3/18/2018	
SEAL 	
DOCUMENT NOT CONSIDERED FINAL UNLESS ALL SIGNATURES COMPLETED	

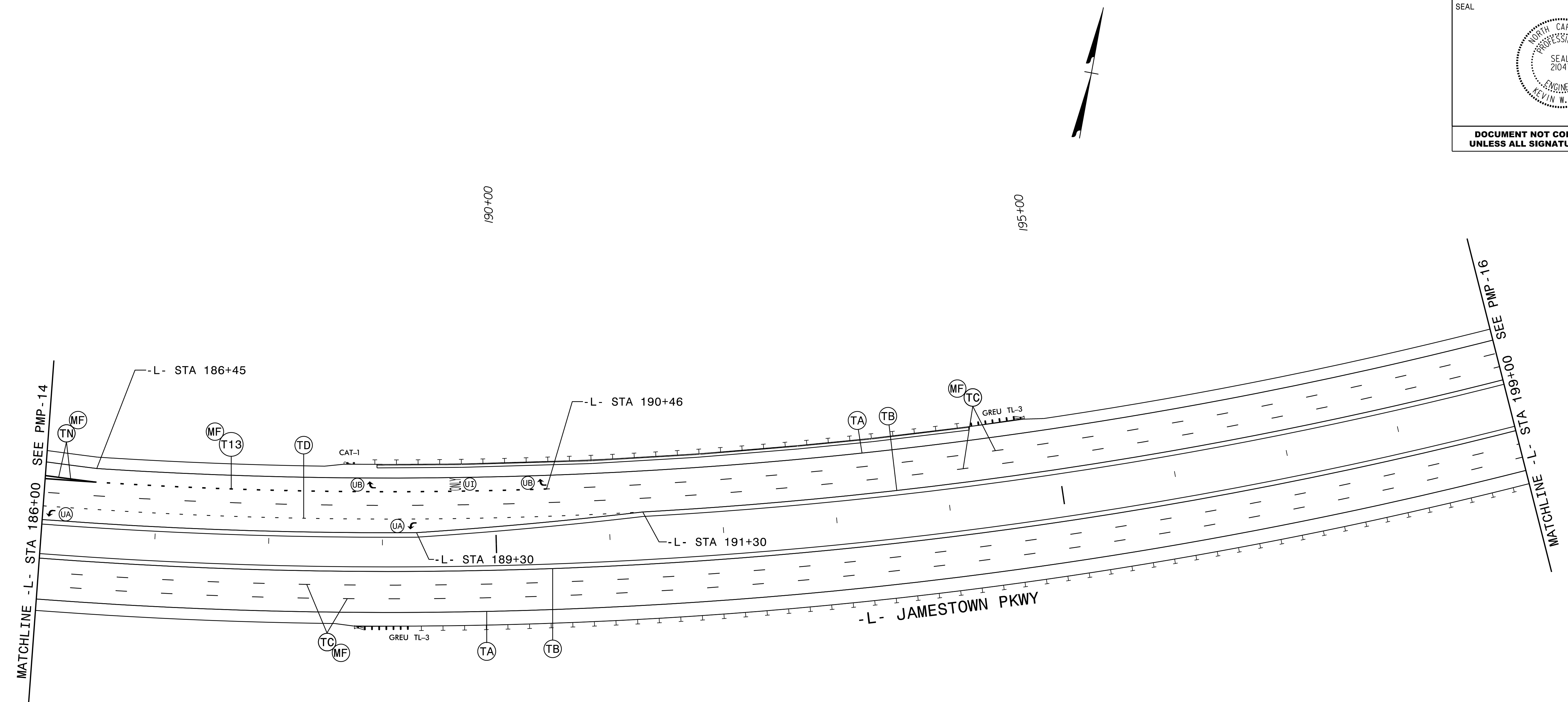

3/18/2018 PMP_PSH15.dgn

PLANS PREPARED BY :



RUMMEL, KLEPPER & KAHL, LLP
900 RIDGEFIELD DRIVE SUITE 350
RALEIGH, NORTH CAROLINA 27609-3960
NC LICENSE NO. F-0112 • (919) 878-9560

LANE WIDTHS 12' UNLESS OTHERWISE SHOWN.

PAVEMENT MARKING DETAIL

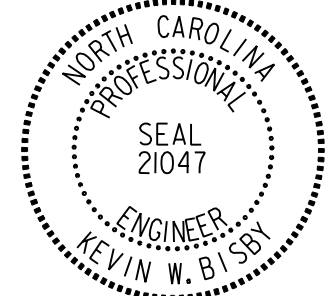
PROJECT REFERENCE NO. U-2412A	SHEET NO. PMP-16
APPROVED: <i>Kevin W. Eskey</i> DATE: 3/18/2018	
SEAL 	
DOCUMENT NOT CONSIDERED FINAL UNLESS ALL SIGNATURES COMPLETED	

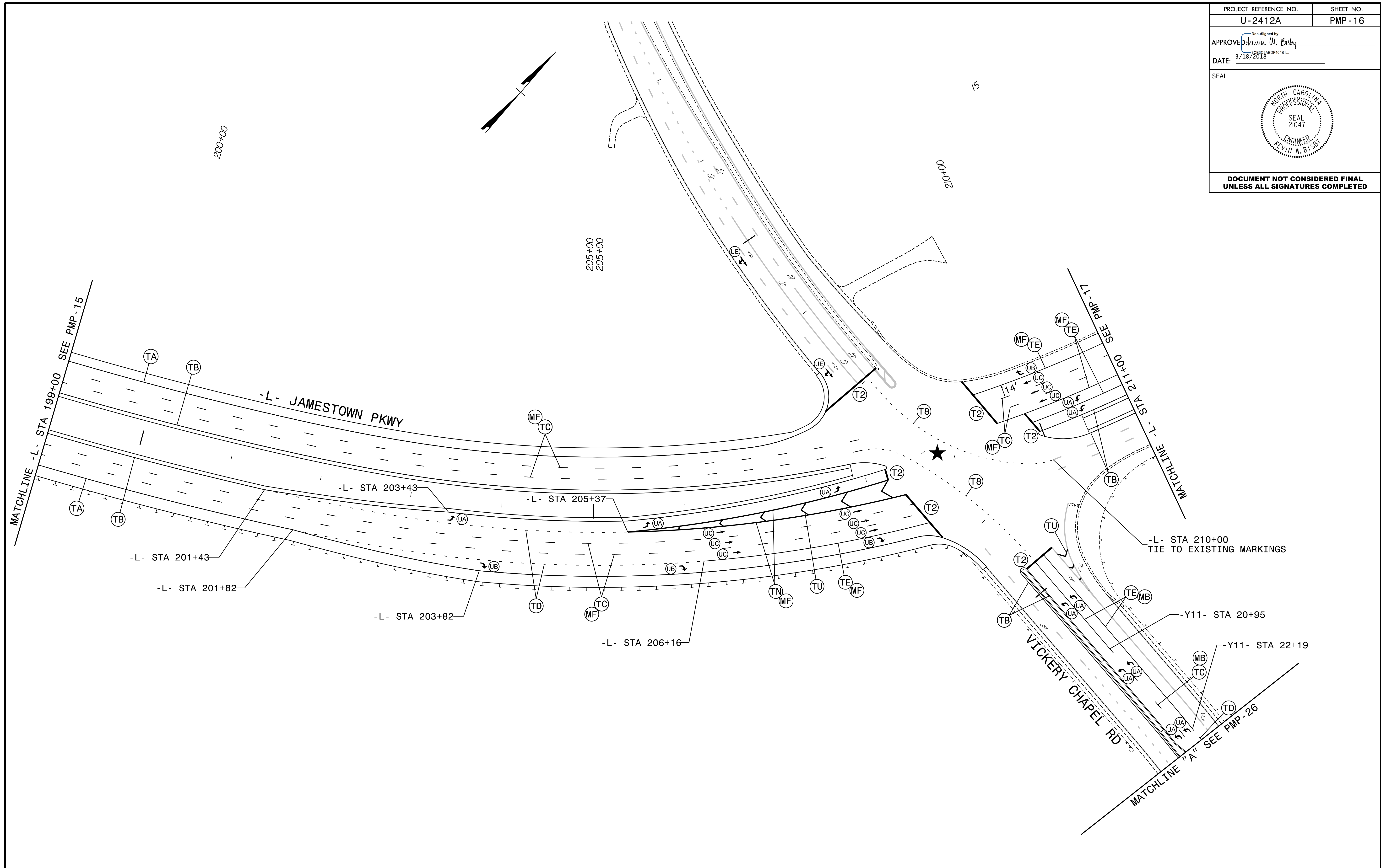

★ TRAFFIC SIGNAL
 LANE WIDTHS 12' UNLESS OTHERWISE SHOWN.
 SEE PMP-16A FOR STOP BAR LOCATIONS.



PAVEMENT MARKING DETAIL

PLANS PREPARED BY :

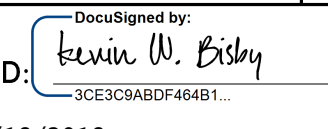

RUMMEL, KLEPPER & KAHL, LLP
 900 RIDGEFIELD DRIVE SUITE 350
 RALEIGH, NORTH CAROLINA 27609-3960
 NC LICENSE NO. F-0112 • (919) 878-9560

3/18/2018 PMP_PSH16.dgn

PROJECT REFERENCE NO. U-2412A	SHEET NO. PMP-16A
APPROVED:  30E3C8A0DF464B1	
DATE: 3/18/2018	
SEAL 	
DOCUMENT NOT CONSIDERED FINAL UNLESS ALL SIGNATURES COMPLETED	

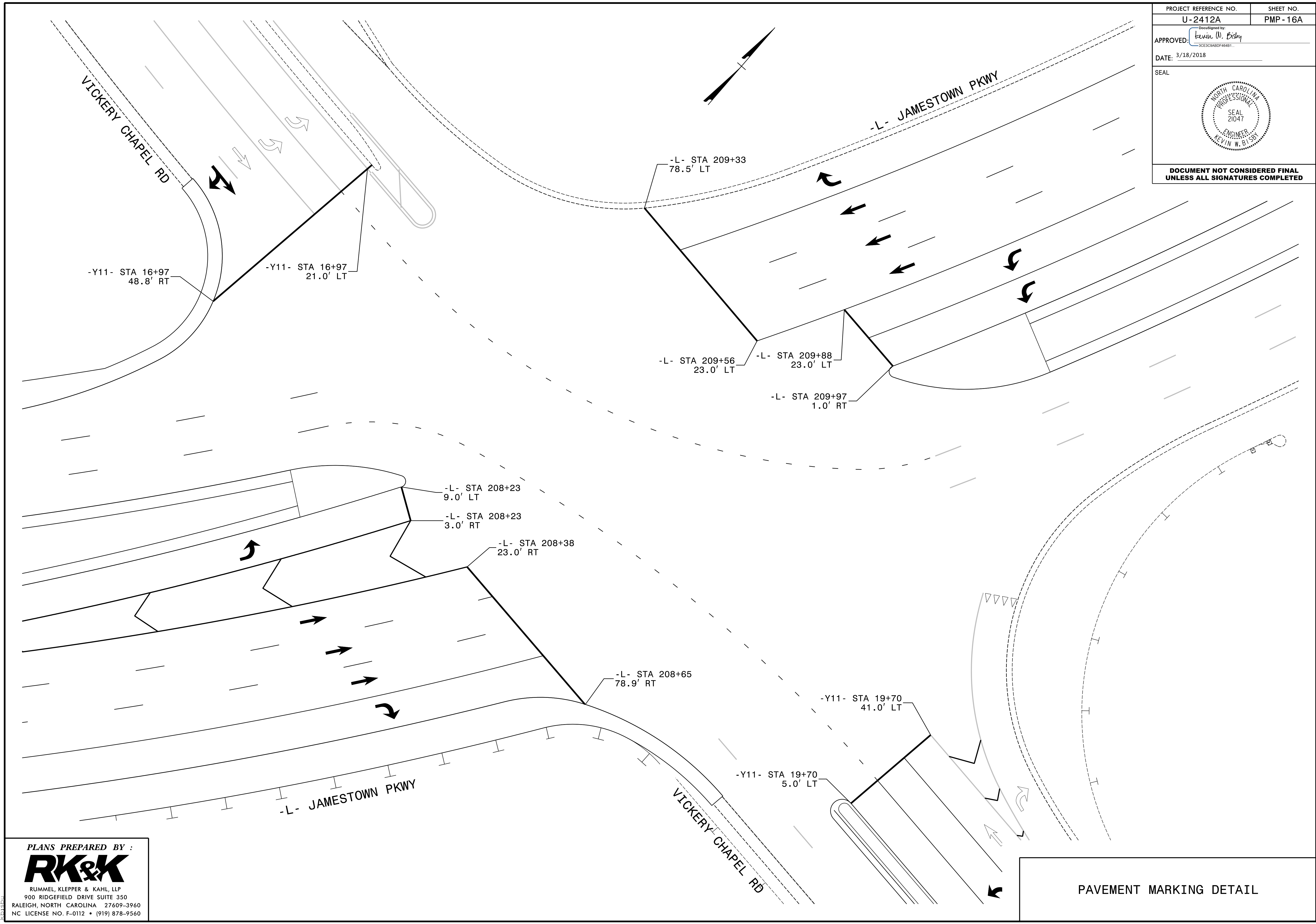

3/18/2018 PMP_PSH16A.dgn

PLANS PREPARED BY :



RUMMEL, KLEPPER & KAHL, LLP
900 RIDGEFIELD DRIVE SUITE 350
RALEIGH, NORTH CAROLINA 27609-3960
NC LICENSE NO. F-0112 • (919) 878-9560

PAVEMENT MARKING DETAIL

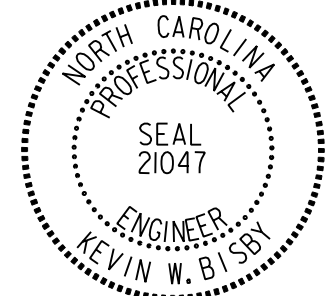
PROJECT REFERENCE NO. U-2412A	SHEET NO. PMP-17
APPROVED: <i>Kevin W. Bishop</i> <small>DocuSigned by: Kevin W. Bishop 3CE3C9ADF464B1...</small>	
DATE: 3/18/2018	
SEAL	
	
DOCUMENT NOT CONSIDERED FINAL UNLESS ALL SIGNATURES COMPLETED	

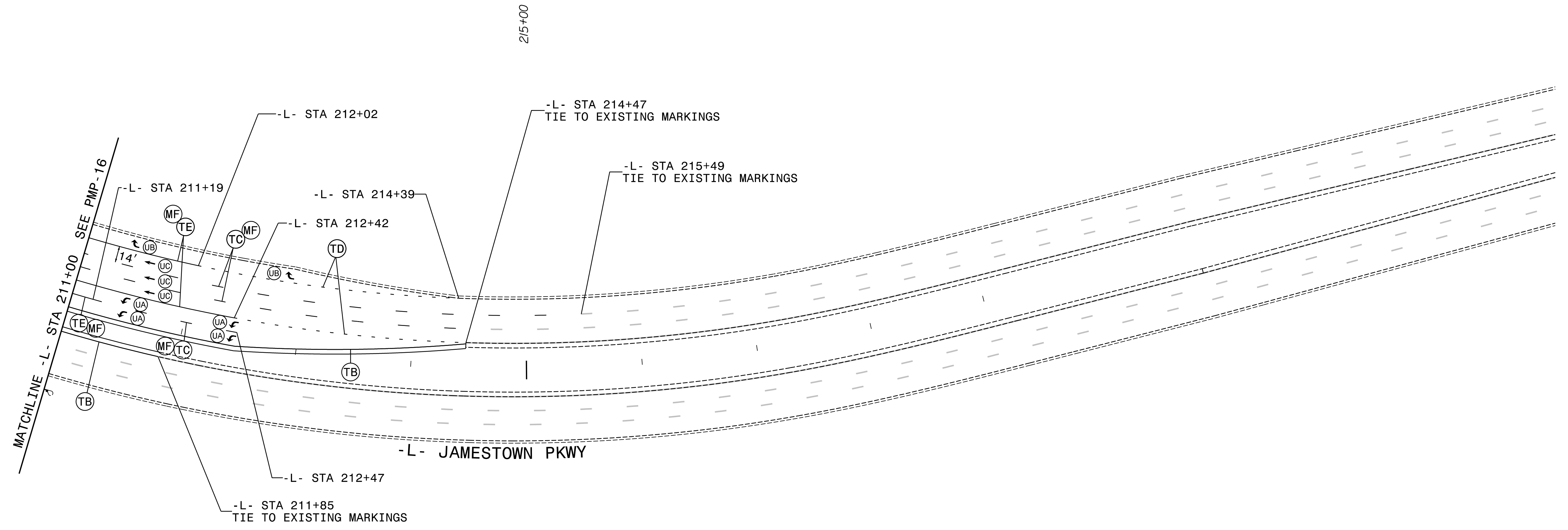

3/18/2018 PMP_PSH17.dgn

PLANS PREPARED BY :

RK&K

RUMMEL, KLEPPER & KAHL, LLP
 900 RIDGEFIELD DRIVE SUITE 350
 RALEIGH, NORTH CAROLINA 27609-3960
 NC LICENSE NO. F-0112 • (919) 878-9560

LANE WIDTHS 12' UNLESS OTHERWISE SHOWN.

PAVEMENT MARKING DETAIL

LANE WIDTHS 12' UNLESS OTHERWISE SHOWN.

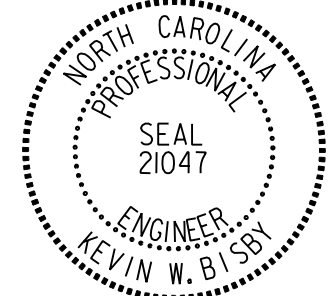
PROJECT REFERENCE NO. U-2412A	SHEET NO. PMP-18
APPROVED: <i>Kevin W. Bisby</i> SCE3C8ADF6481	
DATE: 3/18/2018	
SEAL	
	
DOCUMENT NOT CONSIDERED FINAL UNLESS ALL SIGNATURES COMPLETED	

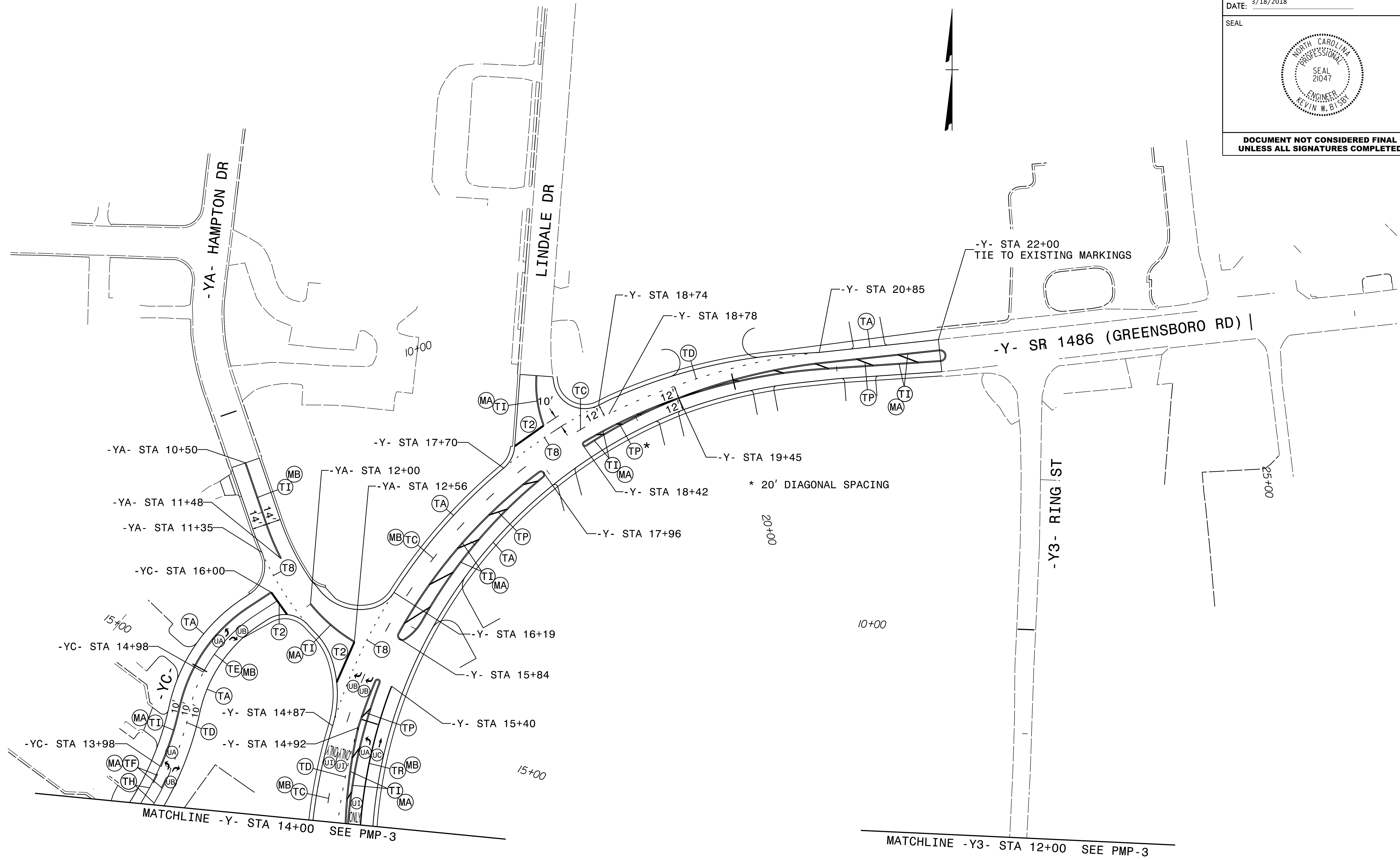

3/18/2018 12:50 PMP_PSH18.dgn

PLANS PREPARED BY :



RUMMEL, KLEPPER & KAHL, LLP
900 RIDGEFIELD DRIVE SUITE 350
RALEIGH, NORTH CAROLINA 27609-3960
NC LICENSE NO. F-0112 • (919) 878-9560

PAVEMENT MARKING DETAIL

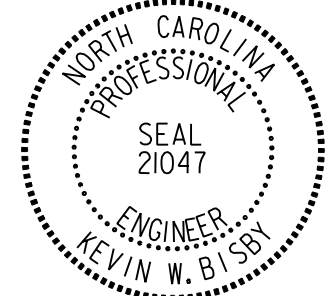
PROJECT REFERENCE NO. U-2412A	SHEET NO. PMP-19
APPROVED: <i>Kevin W. Esling</i> <small>DocuSigned by: 3CE3C9ABDF484B1</small>	
DATE: 3/18/2018	
SEAL	
	
DOCUMENT NOT CONSIDERED FINAL UNLESS ALL SIGNATURES COMPLETED	

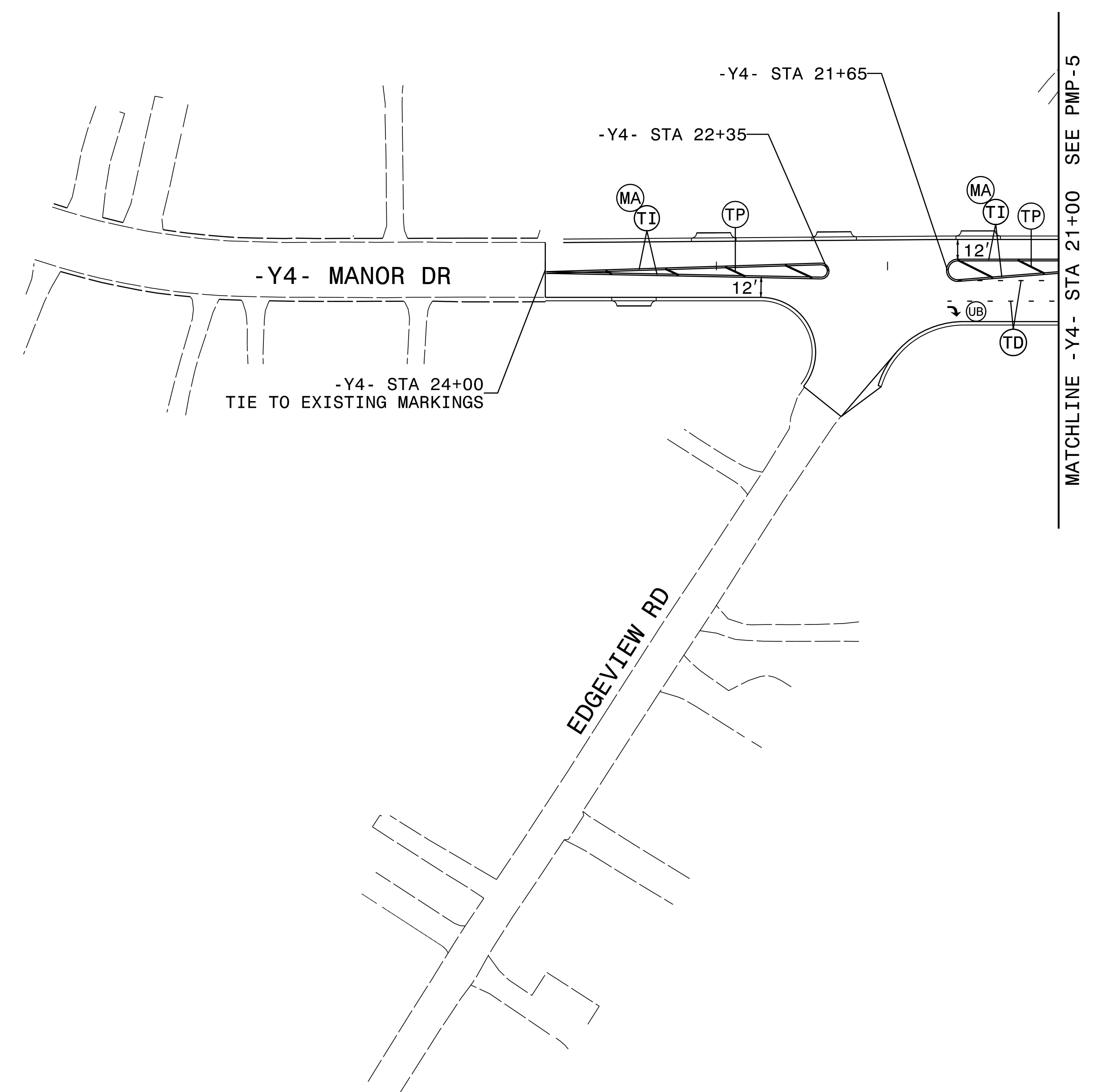

3/18/2018 PMP_PSH19.dgn

PLANS PREPARED BY :

 RUMMEL, KLEPPER & KAHL, LLP
 900 RIDGEFIELD DRIVE SUITE 350
 RALEIGH, NORTH CAROLINA 27609-3960
 NC LICENSE NO. F-0112 • (919) 878-9560

DTHS 12' UNLESS OTHERWISE SHOWN.

PAVEMENT MARKING DETAIL

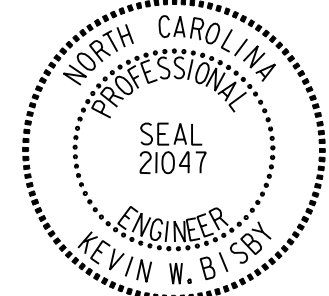
PROJECT REFERENCE NO. U-2412A	SHEET NO. PMP-20
APPROVED: <i>Kevin W. Bishop</i> <small>DocuSigned by: 3CE3C9ABDF46491</small>	
DATE: 3/18/2018	
SEAL	
	
DOCUMENT NOT CONSIDERED FINAL UNLESS ALL SIGNATURES COMPLETED	

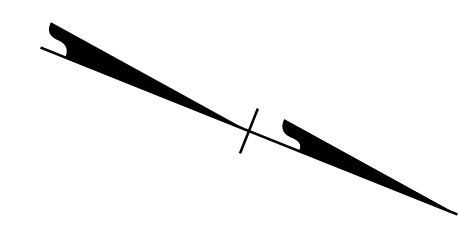

00+01

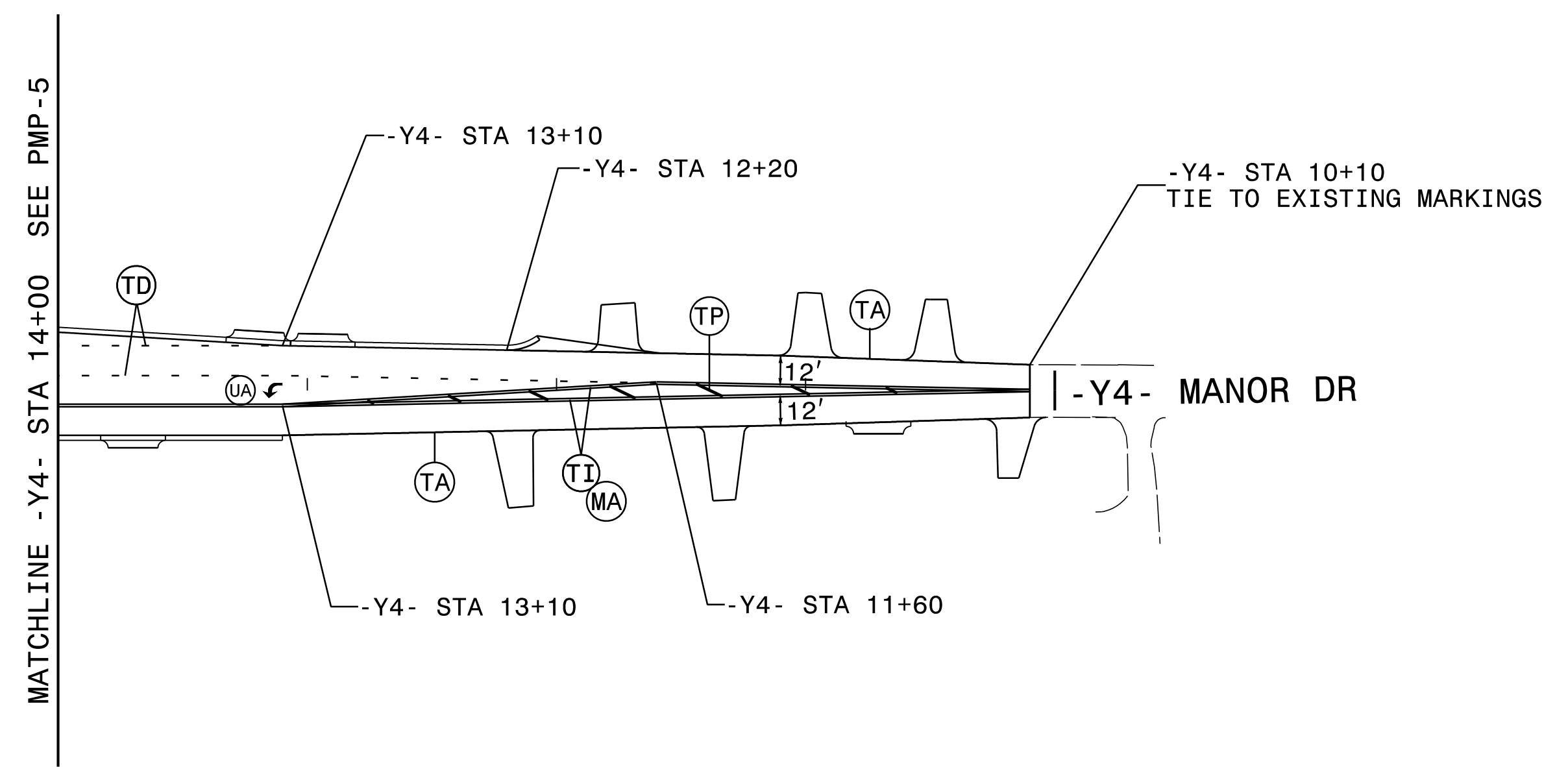



3/18/2018 PMP.PSH20.dgn

PLANS PREPARED BY :

 RUMMEL, KLEPPER & KAHL, LLP
 900 RIDGEFIELD DRIVE SUITE 350
 RALEIGH, NORTH CAROLINA 27609-3960
 NC LICENSE NO. F-0112 • (919) 878-9560

LANE WIDTHS 12' UNLESS OTHERWISE SHOWN.

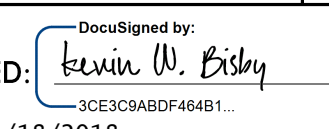
PAVEMENT MARKING DETAIL

PROJECT REFERENCE NO. U-2412A	SHEET NO. PMP-21
APPROVED:  3CE3C8ABDF4481	
DATE: 3/18/2018	
SEAL 	
DOCUMENT NOT CONSIDERED FINAL UNLESS ALL SIGNATURES COMPLETED	

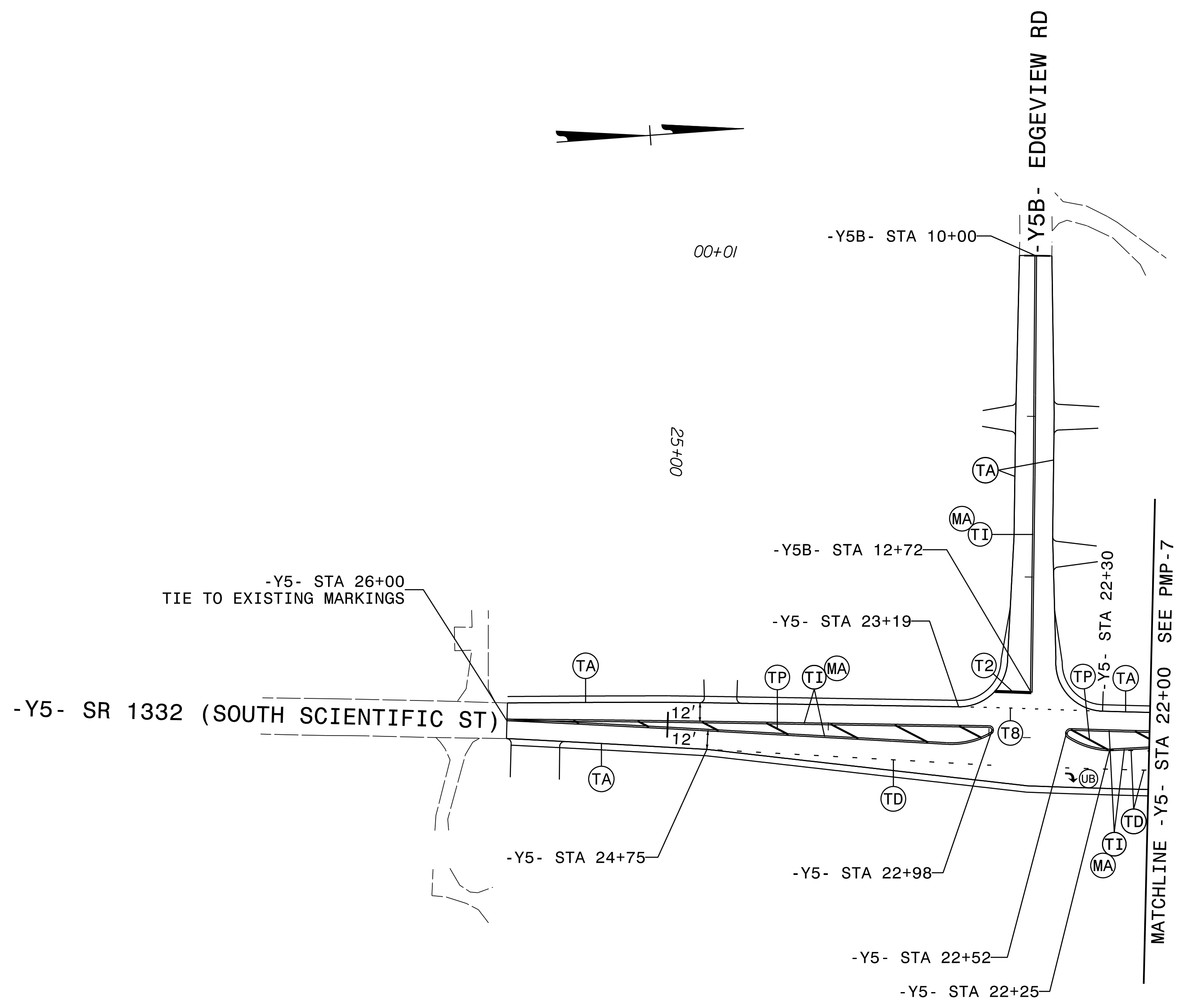

3/18/2018 12:50 PMP_PSH21.dgn
K:\11111

PLANS PREPARED BY :
RK&K
 RUMMEL, KLEPPER & KAHL, LLP
 900 RIDGEFIELD DRIVE SUITE 350
 RALEIGH, NORTH CAROLINA 27609-3960
 NC LICENSE NO. F-0112 • (919) 878-9560

LANE WIDTHS 12' UNLESS OTHERWISE SHOWN.

PAVEMENT MARKING DETAIL

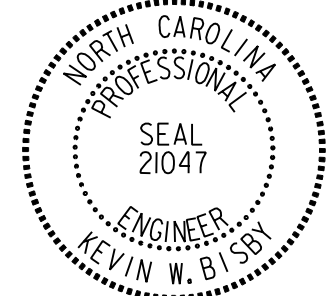
PROJECT REFERENCE NO. U-2412A	SHEET NO. PMP-22
APPROVED: <i>Kevin W. Bisby</i> <small>DocuSigned by: Kevin W. Bisby 3CE3C9A8DF464B1...</small>	
DATE: 3/18/2018	
SEAL	
	
DOCUMENT NOT CONSIDERED FINAL UNLESS ALL SIGNATURES COMPLETED	

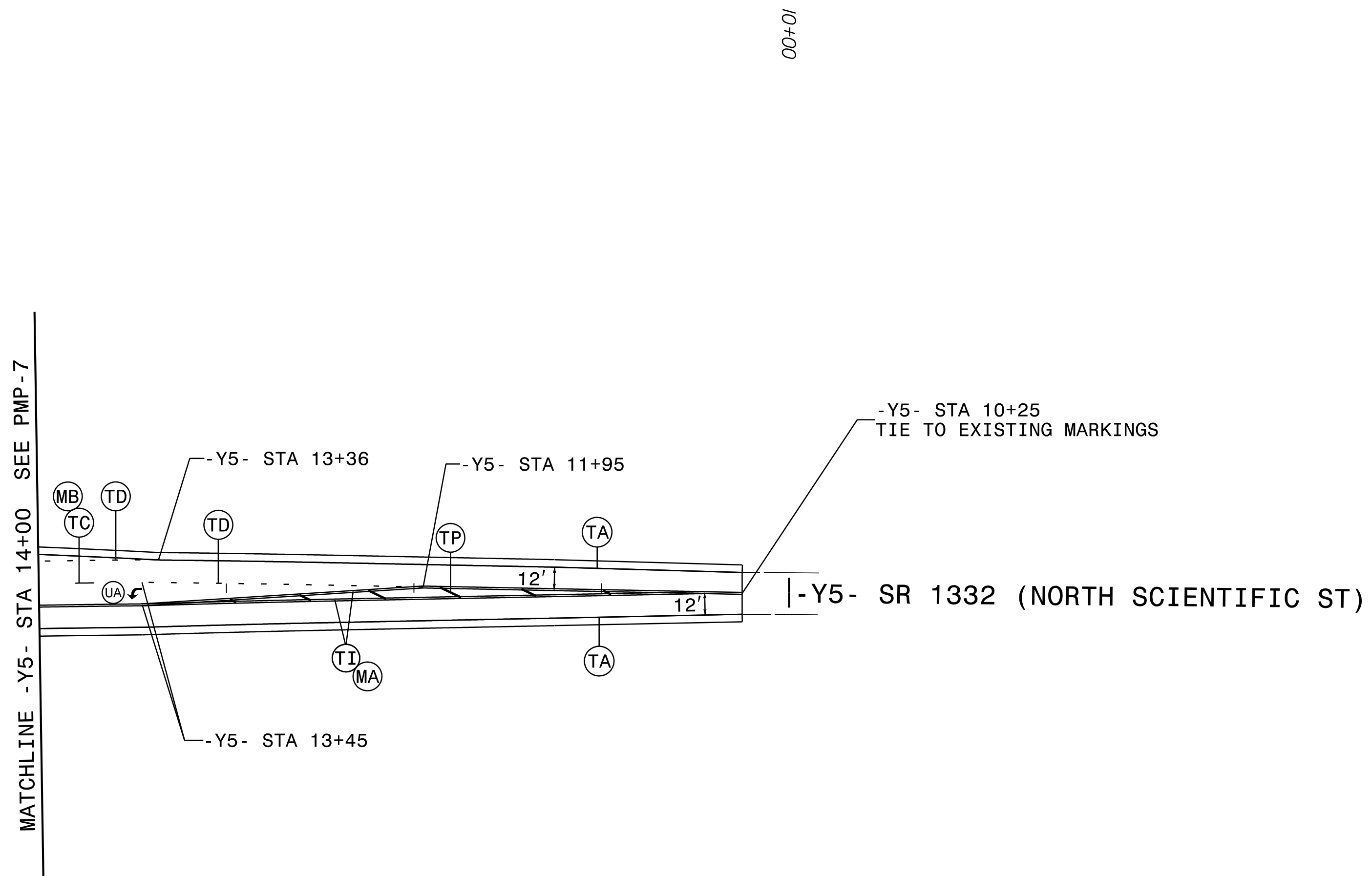

3/18/2018 PMP_PSH22.dgn

PLANS PREPARED BY :

 RUMMEL, KLEPPER & KAHL, LLP
 900 RIDGEFIELD DRIVE SUITE 350
 RALEIGH, NORTH CAROLINA 27609-3960
 NC LICENSE NO. F-0112 • (919) 878-9560

LANE WIDTHS 12' UNLESS OTHERWISE SHOWN.

PAVEMENT MARKING DETAIL

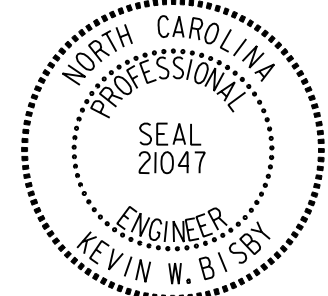
PROJECT REFERENCE NO. U-2412A	SHEET NO. PMP-23
APPROVED: <i>Kevin W. Bisby</i> <small>DocuSigned by: Kevin W. Bisby 3CE3C8ADF6481...</small>	
DATE: 3/18/2018	
SEAL 	
DOCUMENT NOT CONSIDERED FINAL UNLESS ALL SIGNATURES COMPLETED	

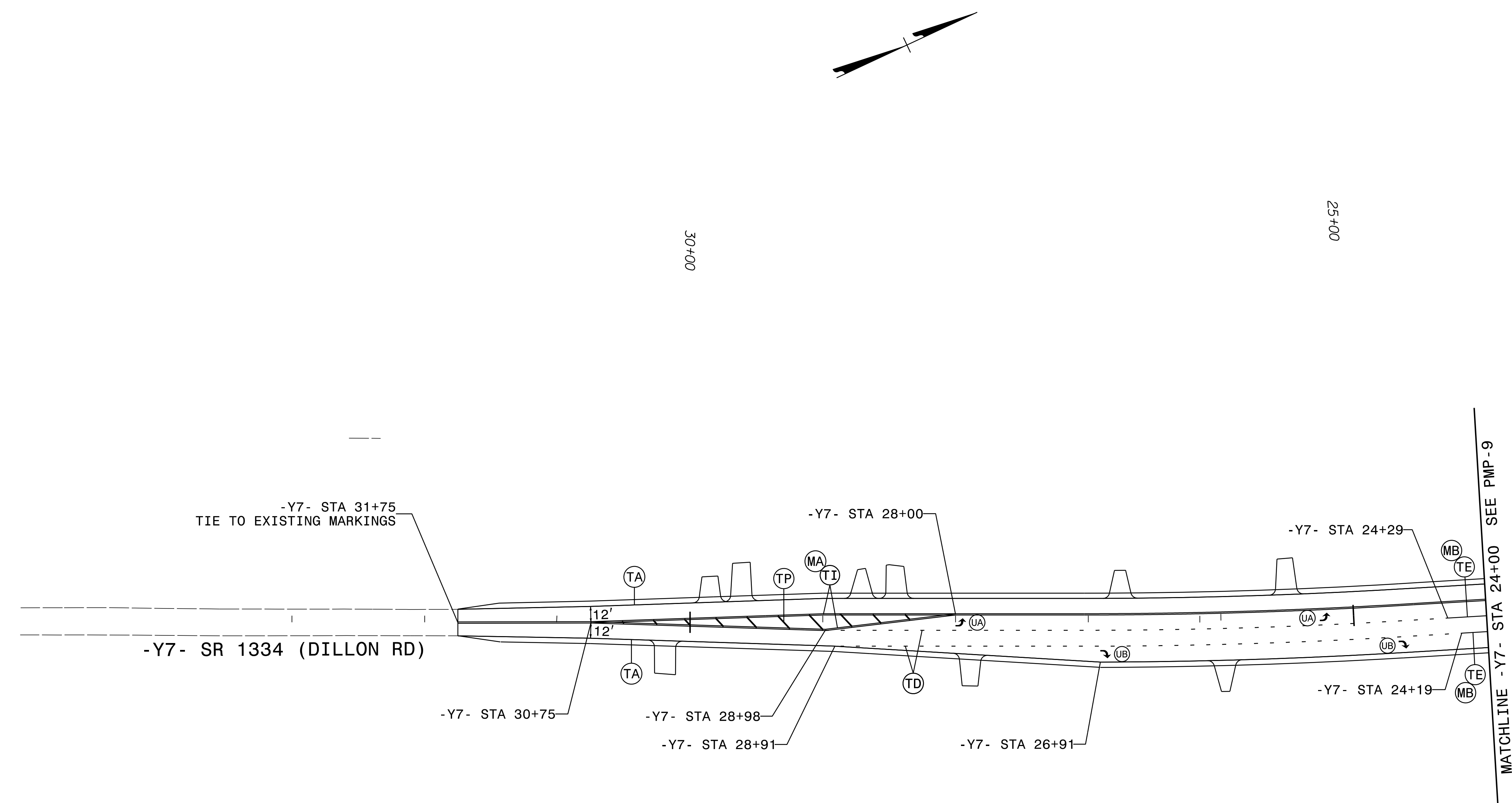

3/18/2018 10:50 AM PMP_PSH23.dgn
K. Bisby

PLANS PREPARED BY :

RK&K

RUMMEL, KLEPPER & KAHL, LLP
900 RIDGEFIELD DRIVE SUITE 350
RALEIGH, NORTH CAROLINA 27609-3960
NC LICENSE NO. F-0112 • (919) 878-9560

LANE WIDTHS 12' UNLESS OTHERWISE SHOWN.

PAVEMENT MARKING DETAIL

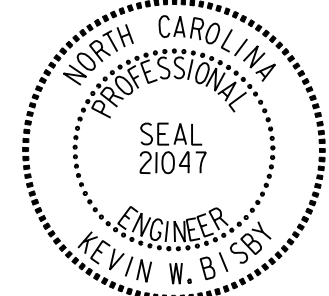
PROJECT REFERENCE NO. U-2412A	SHEET NO. PMP-24
APPROVED: <i>Kevin W. Bishop</i> <small>DocuSigned by: Kevin W. Bishop 3CE3C9ABDF464B1</small>	
DATE: 3/18/2018	
SEAL	
	
DOCUMENT NOT CONSIDERED FINAL UNLESS ALL SIGNATURES COMPLETED	

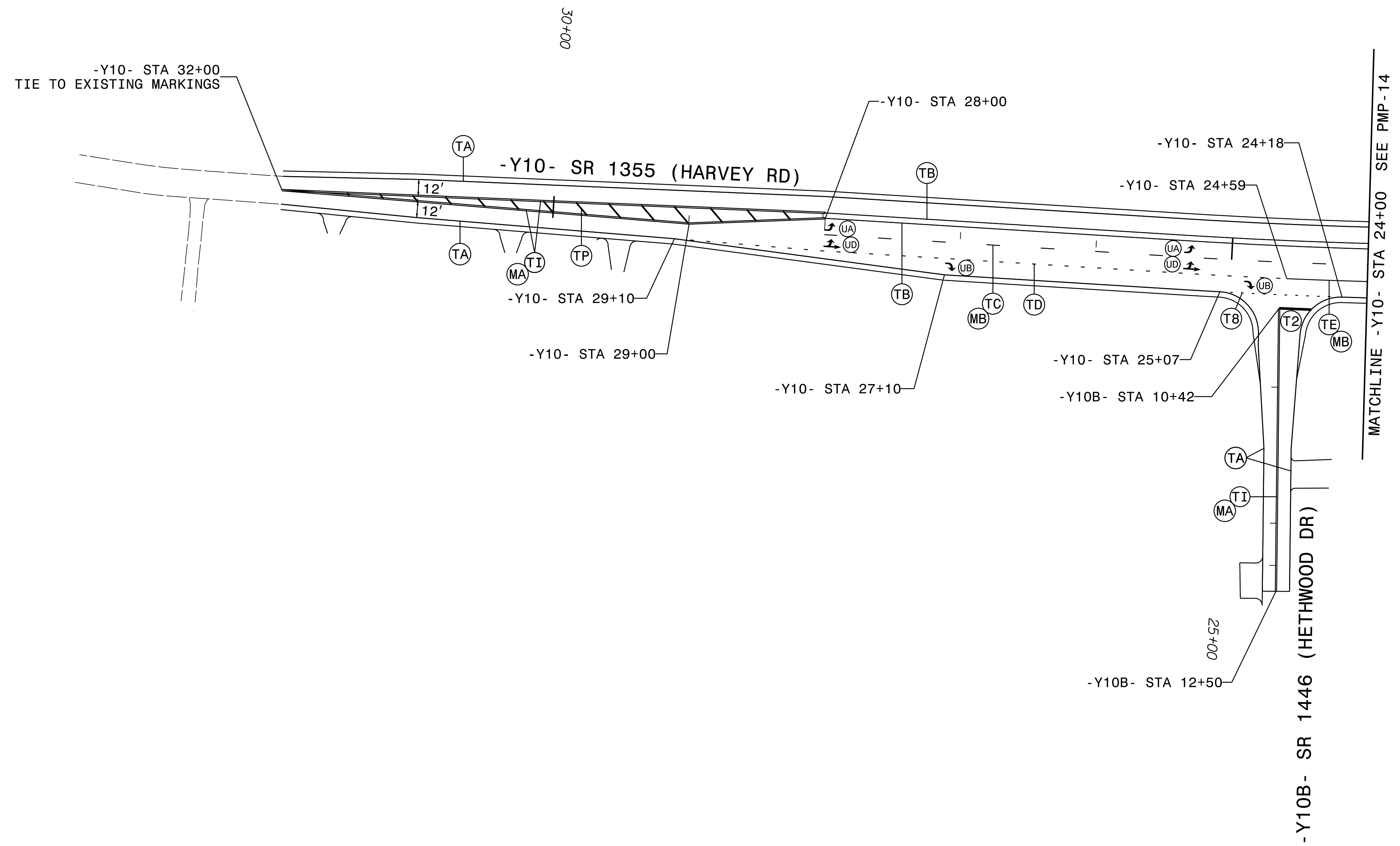

LANE WIDTHS 12' UNLESS OTHERWISE SHOWN.

PAVEMENT MARKING DETAIL

PLANS PREPARED BY :



RUMMEL, KLEPPER & KAHL, LLP
900 RIDGEFIELD DRIVE SUITE 350
RALEIGH, NORTH CAROLINA 27609-3960
NC LICENSE NO. F-0112 • (919) 878-9560

3/18/2018 PMP_PSH24.dgn

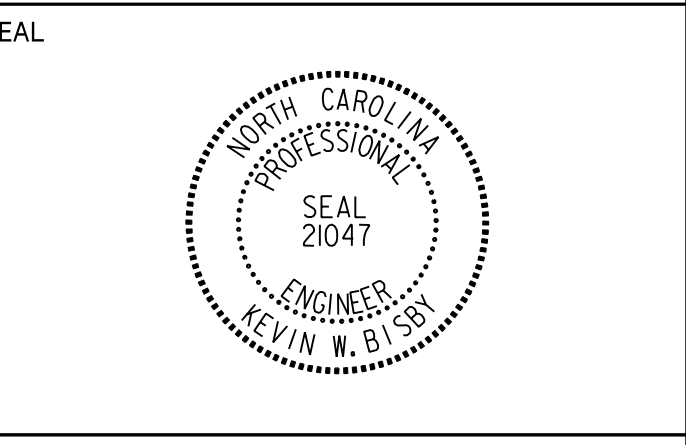

DOCUMENT NOT CONSIDERED FINAL
UNLESS ALL SIGNATURES COMPLETED

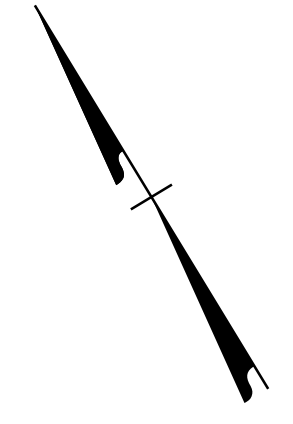

30

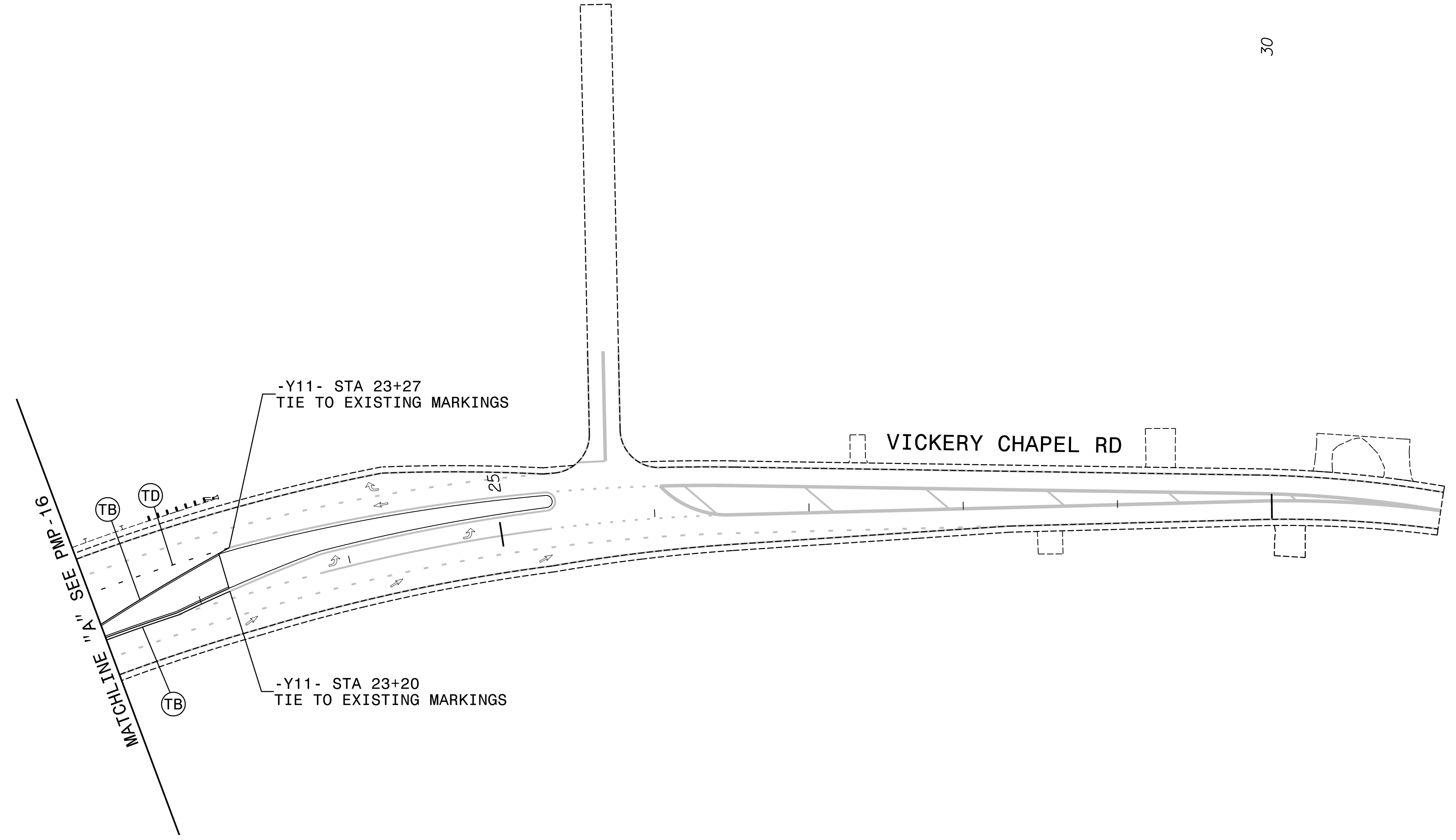

PLANS PREPARED BY :

RUMMEL, KLEPPER & KAHL, LLP
 900 RIDGEFIELD DRIVE SUITE 350
 RALEIGH, NORTH CAROLINA 27609-3960
 NC LICENSE NO. F-0112 • (919) 878-9560

LANE WIDTHS 12' UNLESS OTHERWISE SHOWN.

PAVEMENT MARKING DETAIL

3/18/2018 10:28 AM PMP-26.dgn