

Note:  
 1. Opening in pole base plate shall be equal to pole base inside diameter minus 3 1/2" but shall not be less than 8 1/2".

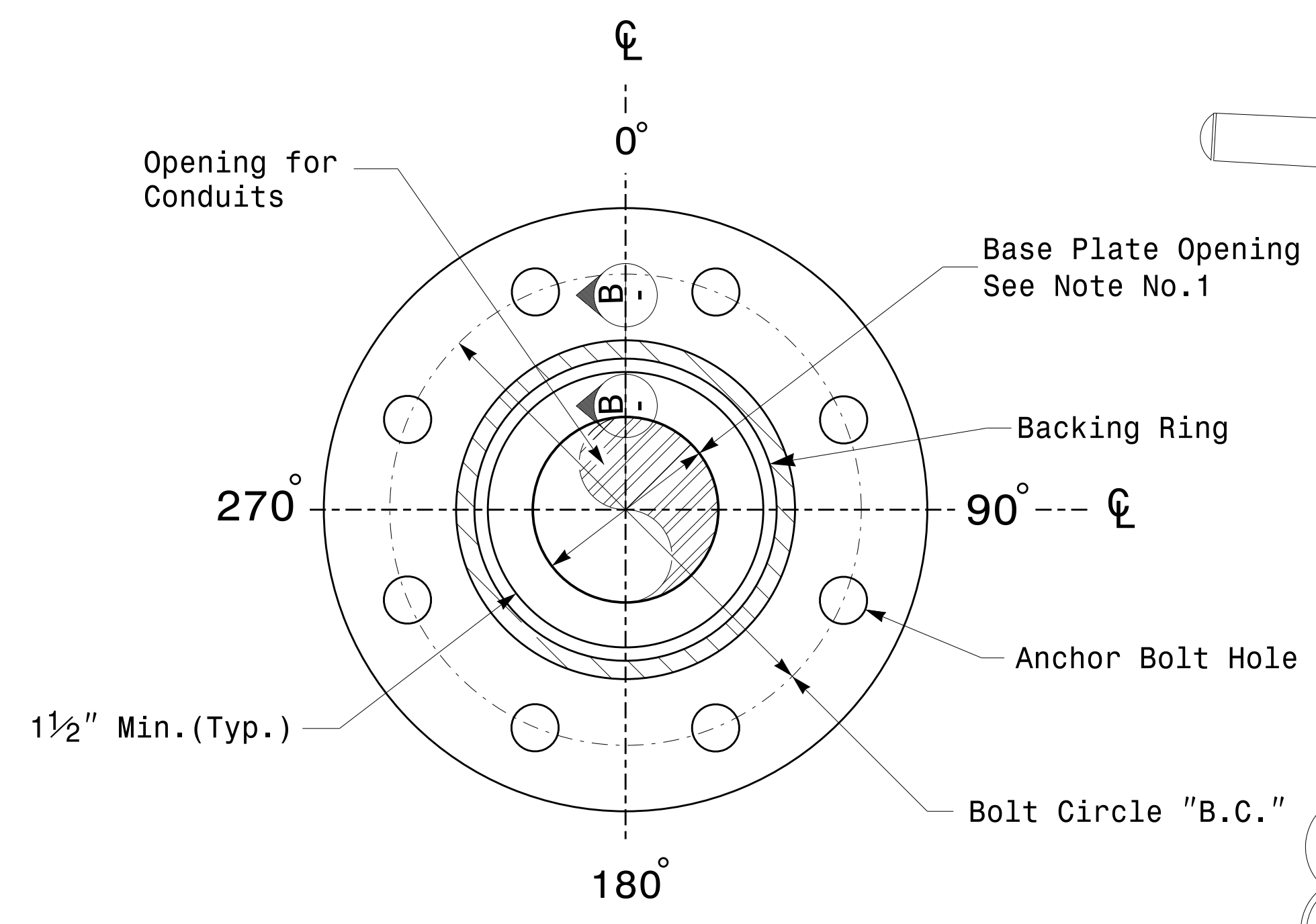

**Section A-A**  
**Pole Base Plate Details**

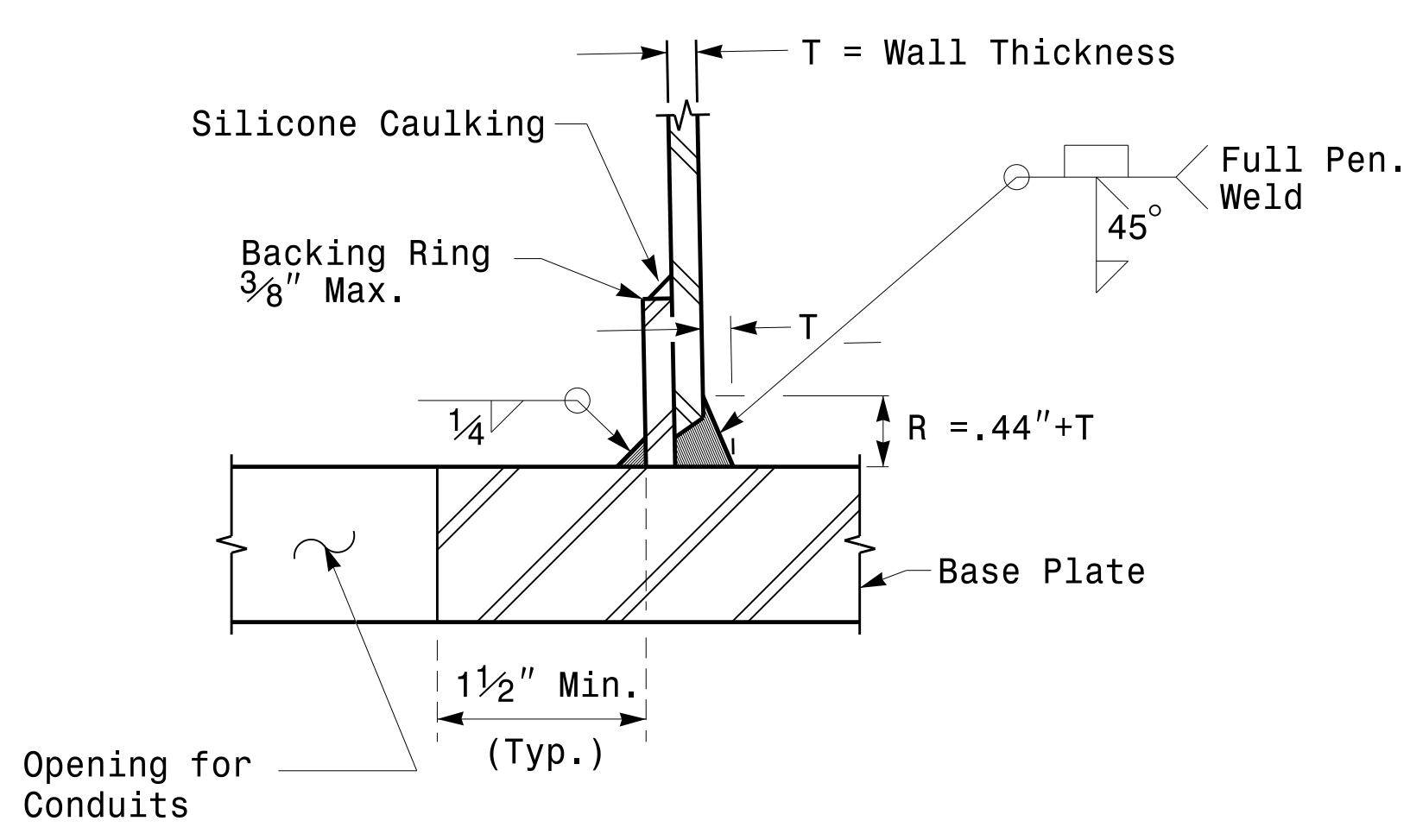

**Section B-B**  
 (Pole Attachment to Base Plate)  
**Full-Penetration Groove Weld Detail**

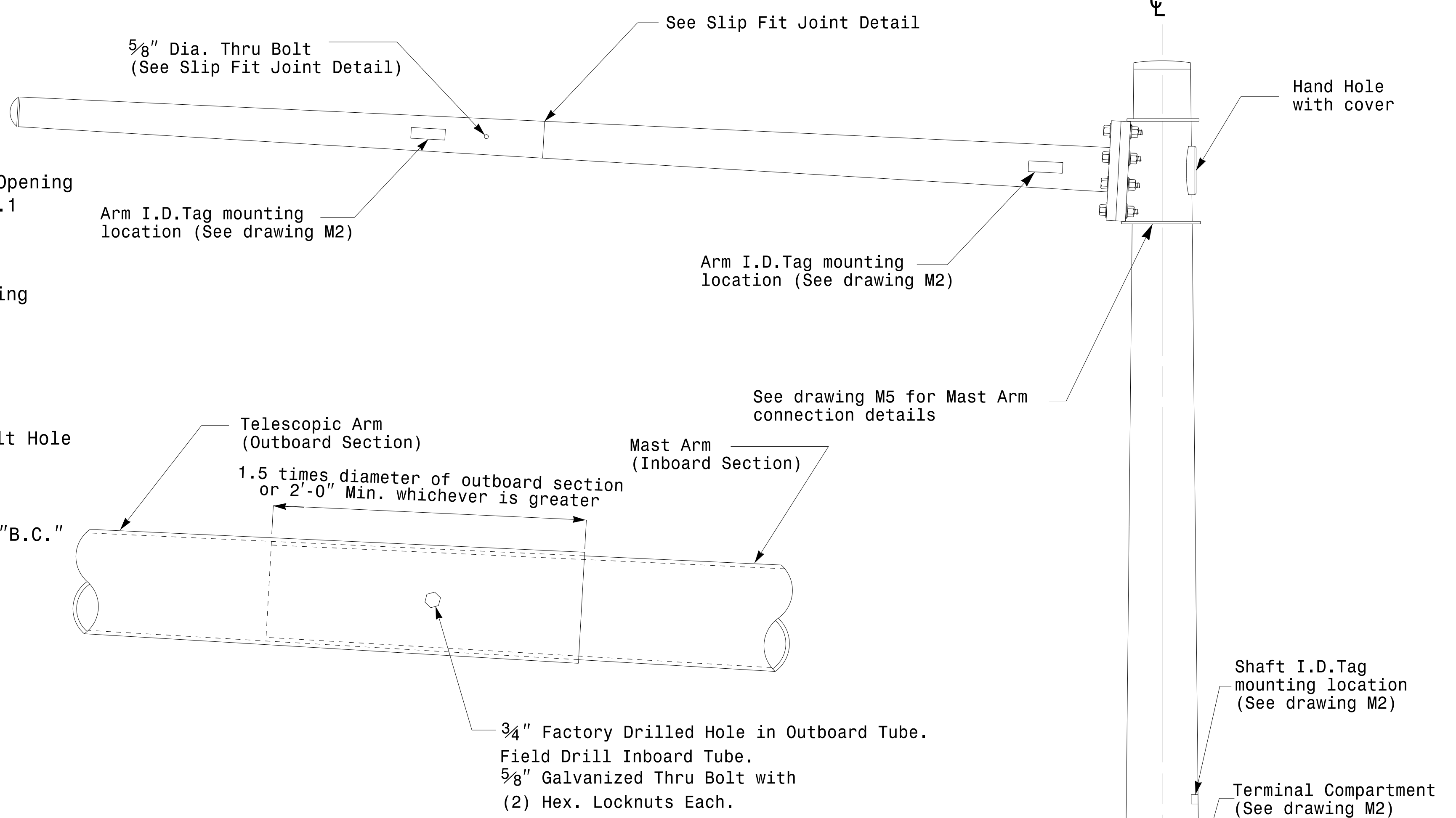

**Slip Fit Joint Detail for Mast Arm**

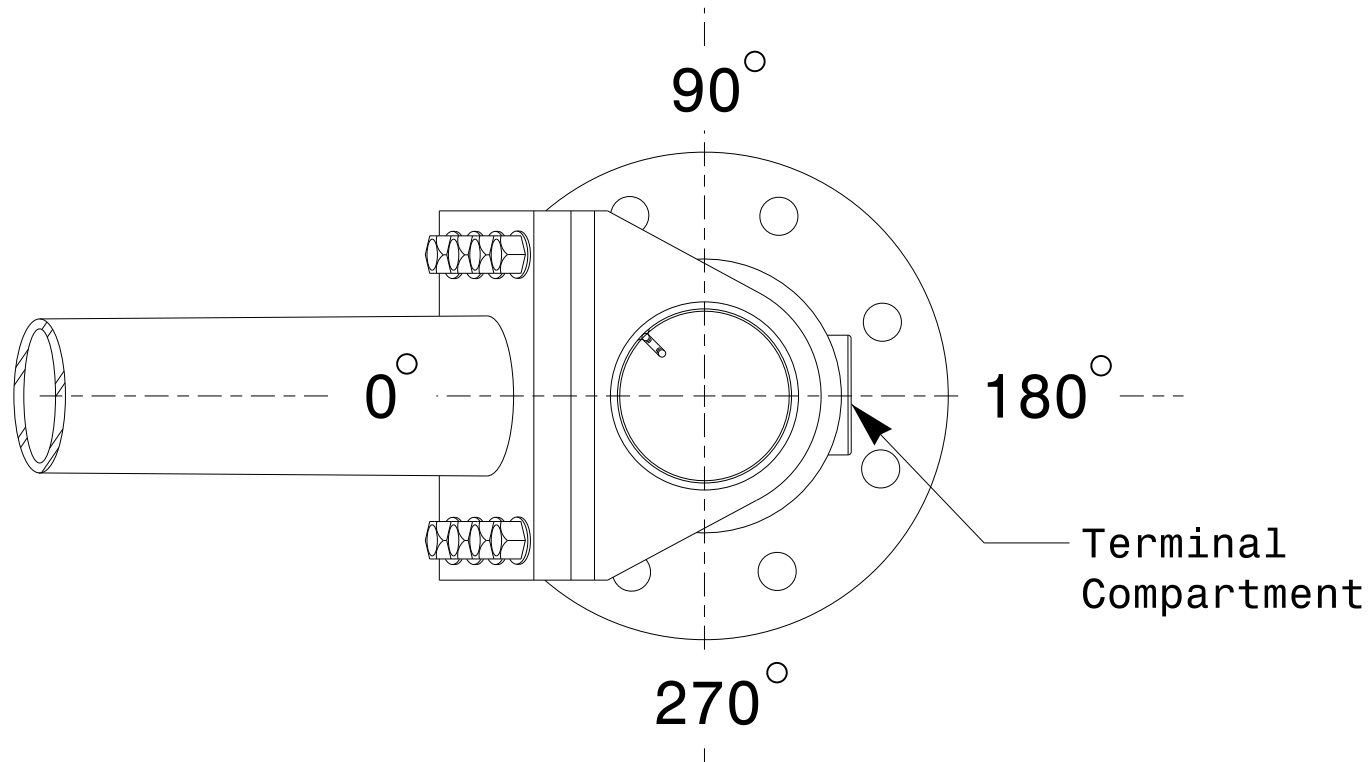

**Mast Arm Radial Orientation**

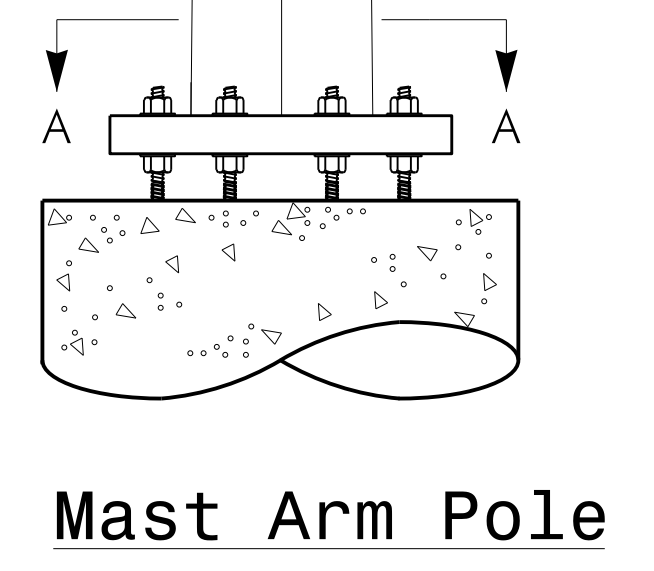

**Mast Arm Pole**

11-0CT-2017 08:33  
 136504115 Signal&Sgnl Design Section Eastern Region\MS Sheets\2016\2014 Sig.M4 Std. Fabrication Detail\Mast Arm Poles.dgn  
 P1/2/2017

**Fabrication Details - Mast Arm Poles**

Prepared in the Offices of:  750 N. Greenfield Pkwy, Garner, NC 27529	<b>Typical Fabrication Details For Mast Arm Poles</b>		SEAL  D. C. SARKAR
	PLAN DATE: OCTOBER 2017 PREPARED BY: N. BITTING	DESIGNED BY: K.C. DURIGON REVIEWED BY: D.C. SARKAR	
SCALE: 0 NA NONE	DocuSigned by: Dinesh C. Sarkar 10/11/2017		DATE