

**This electronic collection of documents is provided  
for the convenience of the user  
and is Not a Certified Document –**



**The documents contained herein were originally issued  
and sealed by the individuals whose names and license  
numbers appear on each page, on the dates appearing  
with their signature on that page.**

**This file or an individual page  
shall not be considered a certified document.**

**STATE OF NORTH CAROLINA  
DEPARTMENT OF TRANSPORTATION**

**SIGNING PLAN  
EDGECOMBE COUNTY**

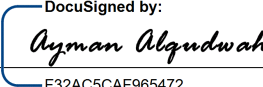
**LOCATION: BRIDGE NO.28 OVER TAR RIVER ON NC 42**

PROJECT REFERENCE NO. <b>B-4932</b>	SHEET NO. <b>SIGN-1</b>
APPROVED:  DocuSigned by: Aymon Alquodwah #324C3CAF96472...	
DATE: <u>2/1/2018</u>	
SEAL 	
<b>DOCUMENT NOT CONSIDERED FINAL UNLESS ALL SIGNATURES COMPLETED</b>	

**T.I.P.: B-4932**

**CONTRACT: C203938**

**SUMMARY OF QUANTITIES**

ITEM NO.		ITEM DESCRIPTION	QUANTITY	UNIT
DESC. NO.	SECT. NO.			
4025000000	901	CONTRACTOR FURNISHED, TYPE D SIGN	6	S.F.
4025000000	901	CONTRACTOR FURNISHED, TYPE E SIGN	13.5	S.F.
4025000000	901	CONTRACTOR FURNISHED, TYPE F SIGN	18.38	S.F.
4072000000	903	SUPPORTS, 3 LB STEEL U-CHANNEL	109	L.F.
4096000000	904	SIGN ERECTION, TYPE D	2	EA.
4102000000	904	SIGN ERECTION, TYPE E	3	EA.
4108000000	904	SIGN ERECTION, TYPE F	3	EA.
4116100000	904	SIGN ERECTION, RELOCATE SIGN TYPE F (GROUND MOUNTED)	1	EA.
4155000000	907	DISPOSAL OF SIGN SYSTEM, U-CHANNEL	7	EA.

**ROADWAY STANDARD DRAWING**

THE FOLLOWING ROADWAY STANDARDS AS APPEAR IN "ROADWAY STANDARD DRAWINGS" - PROJECT SERVICES UNIT - N.C. DEPARTMENT OF TRANSPORTATION - RALEIGH, N.C., DATED JANUARY 2018 ARE APPLICABLE TO THIS PROJECT AND BY REFERENCE HEREBY ARE CONSIDERED A PART OF THESE PLANS:

STD. NO.	TITLE
904.10	ORIENTATION OF GROUND MOUNTED SIGNS
904.50	MOUNTING OF TYPE 'D', 'E' AND 'F' SIGNS ON 'U' CHANNEL POSTS

**GENERAL NOTES**

- . SIGNS FURNISHED BY CONTRACTOR
- . IF REMOVAL OR RELOCATION OF SIGNS ON PRIVATE STREET (NON-STATE MAINTAINED) IS REQUIRED DUE TO CONSTRUCTION, THE CONTRACTOR SHALL INFORM THE ENGINEER. THE WORK WILL BE COMPLETED BY OTHERS.
- . WHEN NOT STATIONED OR DIMENSIONED ON PLANS, ALL 'E' AND 'F' SIGNS SHALL BE FIELD LOCATED BY THE ENGINEER
- . WHEN EXISTING SIGNS ARE REMOVED AND INSTALLED ON NEW SUPPORTS, THE RE-ERECTION SHALL IMMEDIATELY FOLLOW THE REMOVAL.
- . THE BACKGROUND FOR TYPE E & F SIGNS SHALL BE TYPE C REFLECTIVE SHEETING.
- . SEE ROADWAY PLANS FOR GUARD/GUIDE RAIL DETAILS.

**INDEX**

SHEET NO.	DESCRIPTION
SIGN-1	TITLE SHEET
SIGN-2	SIGN DESIGNS AND E AND F SIGNS
SIGN-3	SIGN DETAIL SHEET

PLAN PREPARED BY: N.C.D.O.T. SIGNING AND DELINEATION UNIT

A. I. ALQUDWAH, P.E. SIGNING & DELINEATION REGIONAL ENGINEER

D. M. EATON, P.E. SIGNING & DELINEATION PROJECT DESIGN ENGINEER

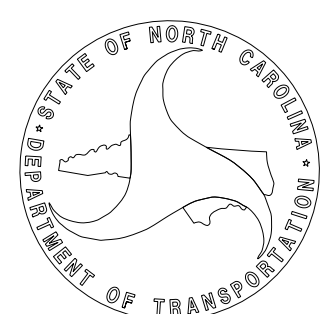

SYSTEMS DESIGN CONSULTANTS

APPROVED: *Ayman Aljoudah*  
F32AC5CAE965472  
 DATE: 12/12/2017



**DOCUMENT NOT CONSIDERED FINAL  
UNLESS ALL SIGNATURES COMPLETED**

**401** QUANTITY REQ'D   1  

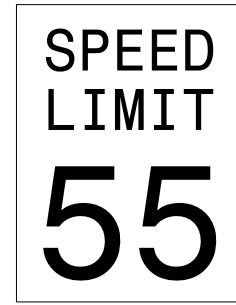

24" X 30"  
R2-1

ONE "U" POST PER SIGN

**501** QUANTITY REQ'D   1  



24" X 12"



24" X 24"

ONE "U" POST PER SIGN

**402** QUANTITY REQ'D   1  

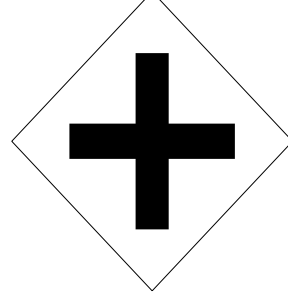

30" X 30"  
W2-1

ONE "U" POST PER SIGN

**502** QUANTITY REQ'D   1  

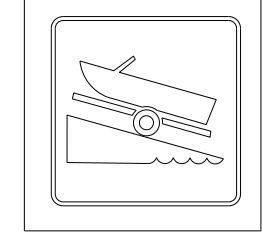

24" X 24"  
RS-054

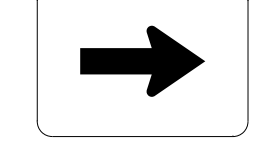

21" X 15"  
M6-1

WHITE LEGEND/BORDER  
BROWN BACKGROUND

ONE "U" POST PER SIGN

**403** QUANTITY REQ'D   1  



18" X 18"  
W13-1P

MOUNT BELOW SIGN 402  
IN .1. INSTALLATIONS

**503** QUANTITY REQ'D   1  

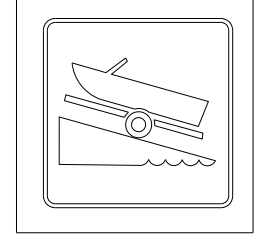

24" X 24"  
RS-054

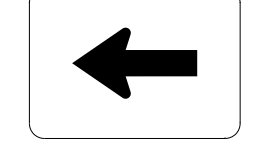

21" X 15"  
M6-1

WHITE LEGEND/BORDER  
BROWN BACKGROUND

ONE "U" POST PER SIGN

SIGN NUMR: 301,302 TYPE: D Ground QUANTITY: 2	BACKG. COLOR: Green COPY COLOR: White	DESIGN BY: DME PROJECT ID: B-4932	CHECKED BY: AIA LOCATION: Edgecombe Co.	DATE: Nov 09, 2017 DIV: 04	N. C. DEPARTMENT OF TRANSPORTATION DIVISION OF HIGHWAYS TRANSPORTATION MOBILITY AND SAFETY SIGNING AND DELINEATION
---	--	--------------------------------------	--	-------------------------------	---

SIGN WIDTH: 2'-0"  
HEIGHT: 1'-6"  
TOTAL AREA: 3.0 Sq.Ft.

SYMBOL	X	Y	WID	HT

MAT'L: 0.063" ALUMINUM

BORDER TYPE: FLUSH  
RECESS: 0"  
WIDTH: 0.5"  
RADII: 1.5"  
NO. Z BARS:  
LENGTH:

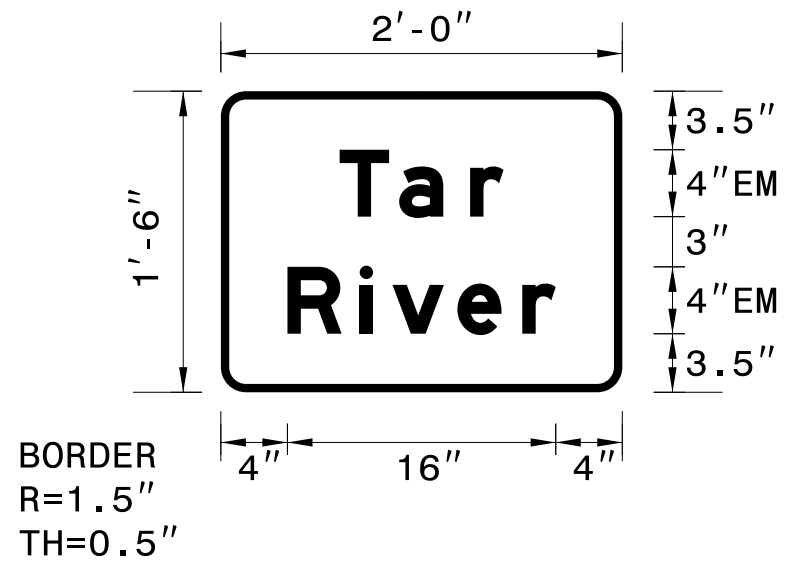

BORDER  
R=1.5"  
TH=0.5"

USE NOTES: 2,5

- Legend and border shall be direct applied Grade A reflective sheeting.
- Legend and border shall be direct applied Grade C reflective sheeting.
- Shields shall be Grade A reflective sheeting on 0.032" aluminum and demountable.
- Background shall be Grade B reflective sheeting.
- Background shall be Grade C reflective sheeting.
- Center arrow(s) vertically on sign.

Letter spacings are to start of next letter										Series/Size
										Text Length
	T	a	r							EM 2000
7.1	3.6	4.2	2	7.1						9.8
	R	i	v	e	r					EM 2000
4	4.3	2	3.9	3.9	2	4				16

Spacing Factor is 1 unless specified otherwise  
FILENAME: GSENG

**TYPE "D" SIGN DESIGN  
TYPE "E" & "F" SIGNS**

SYSTEMS DESIGN & CONSTRUCTION  
 1100 W. HARRIS STREET  
 RICHMOND, VA 23261  
 (804) 343-8800  
 WWW.SDCONSTRUCTION.COM

