

DocuSign 5/14/2018

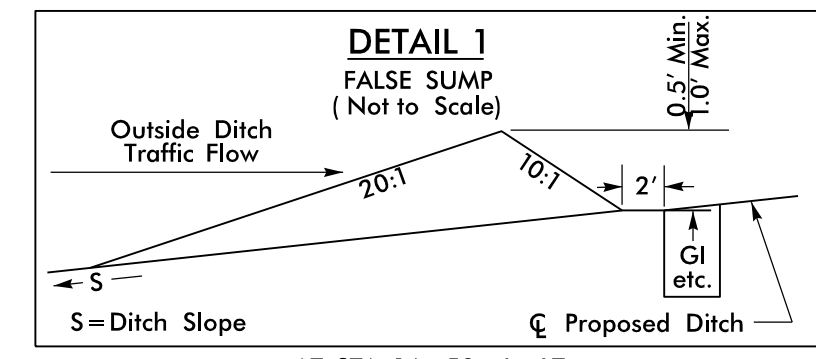

DOCUMENT NOT CONSIDERED FINAL UNLESS ALL SIGNATURES COMPLETED

SPECIAL DITCH DETAILS



AT STA. 14+59 -L- LT
 AT STA. 23+23 -L- LT
 AT STA. 10+75.3 -YIRPA- RT
 AT STA. 18+29 -YIRPB- RT
 AT STA. 21+14 -YIRPB- RT
 AT STA. 24+22 -YIRPB- LT
 AT STA. 17+45 -YIRPC- LT
 AT STA. 19+36 -YIRPC- LT

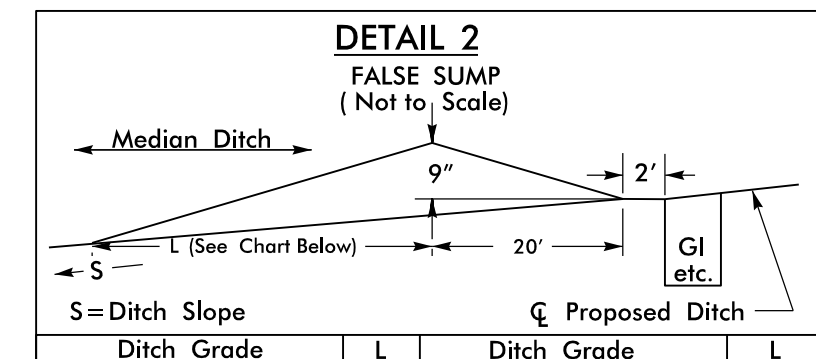

Ditch Grade	L	Ditch Grade	L
0.0% To 2.0%	20'	Over 4.0% To 6.0%	40'
Over 2.0% To 4.0%	30'	Over 6.0%	50'

AT STA. 17+79 -L- CL
 AT STA. 23+23 -L- CL
 AT STA. 27+13 -L- CL
 AT STA. 39+62.9 -L- CL

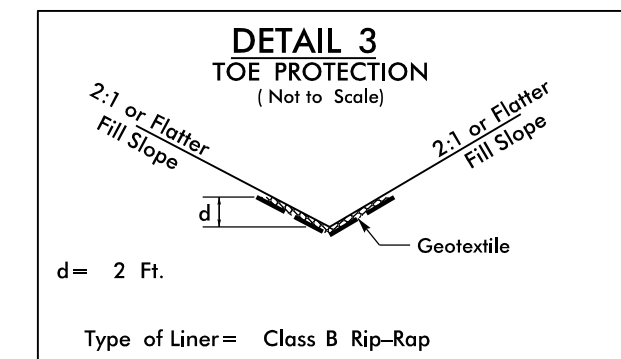

Type of Liner = Class B Rip-Rap
 FROM STA. 14+48 TO STA. 17+06 -YIRPB- LT
 FROM STA. 17+06 TO STA. 18+11 -YIRPB- LT
 FROM STA. 19+00 TO STA. 21+65 -YIRPB- LT

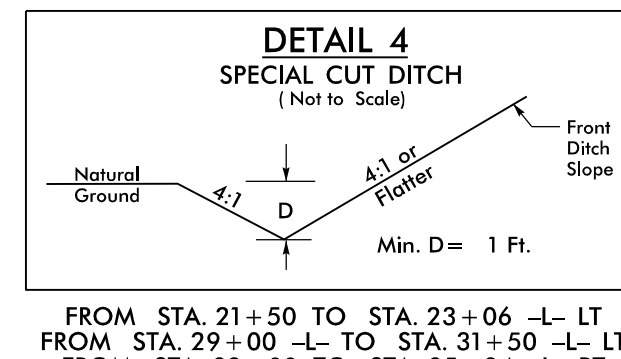

FROM STA. 21+50 TO STA. 23+06 -L- LT
 FROM STA. 29+00 -L- TO STA. 31+50 -L- LT
 FROM STA. 32+00 TO STA. 33+34 -L- RT
 FROM STA. 18+63 -YIRPA- TO STA. 21+67 -YIRPA- LT
 FROM STA. 21+28 TO STA. 21+88 -YIRPB- RT
 FROM STA. 15+93 TO STA. 19+26 -YIRPD- RT
 FROM STA. 21+03 TO STA. 21+77 -YIRPD- RT

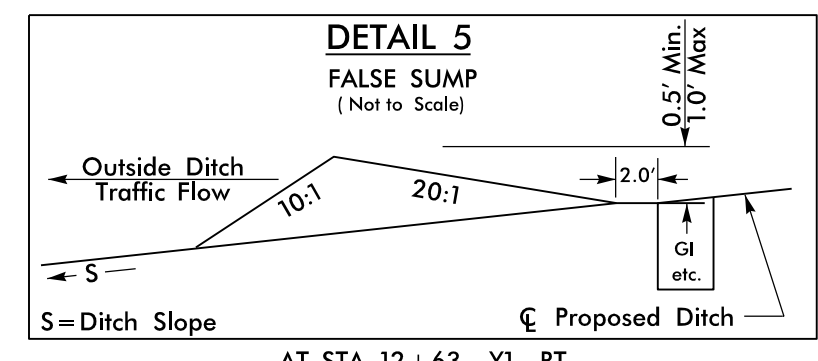

AT STA. 12+63 -YI- RT
 AT STA. 15+13 -YI- RT
 AT STA. 11+02 -YIRPD- LT
 AT STA. 19+40 -YIRPD- RT

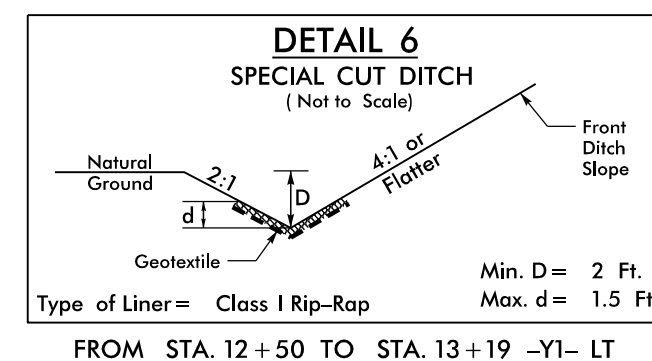

Type of Liner = Class I Rip-Rap
 Min. D = 2 Ft.
 Max. d = 1.5 Ft.
 FROM STA. 12+50 TO STA. 13+19 -YI- LT
 FROM STA. 15+50 TO 16+50 -YI- LT

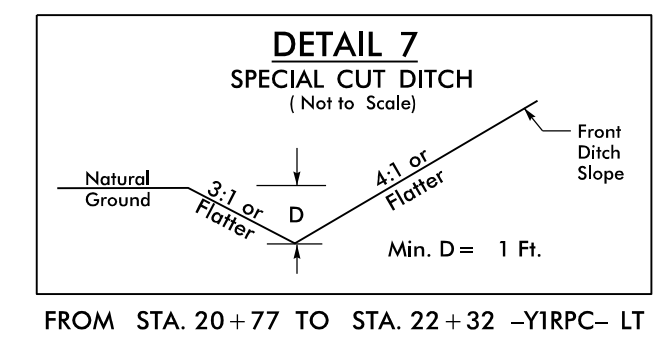

Min. D = 1 Ft.
 FROM STA. 20+77 TO STA. 22+32 -YIRPC- LT

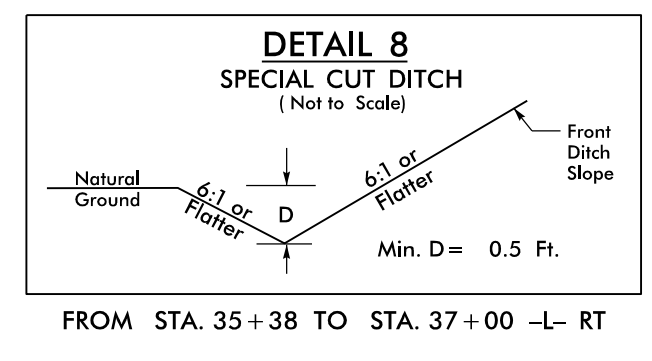

Min. D = 0.5 Ft.
 FROM STA. 35+38 TO STA. 37+00 -L- RT

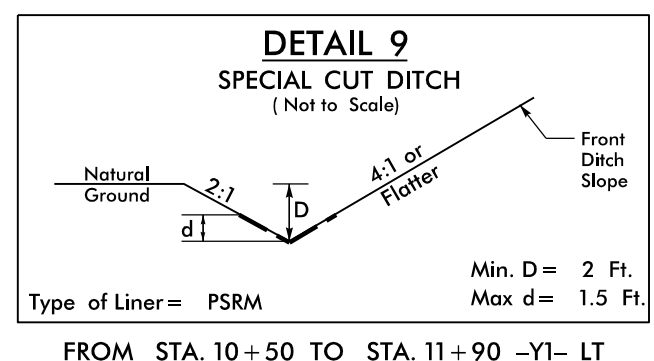

Type of Liner = PSRM
 Min. D = 2 Ft.
 Max. d = 1.5 Ft.
 FROM STA. 10+50 TO STA. 11+90 -YI- LT

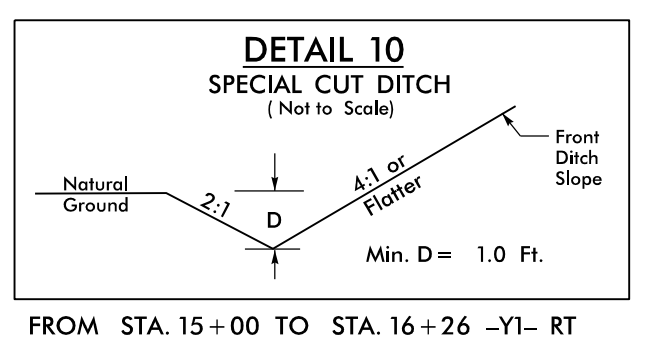

Min. D = 1.0 Ft.
 FROM STA. 15+00 TO STA. 16+26 -YI- RT

REVISIONS

5/14/18

5/10/2018 8:44:48 PM PS-H02D-1.dgn
 USER: jh02