

39

4

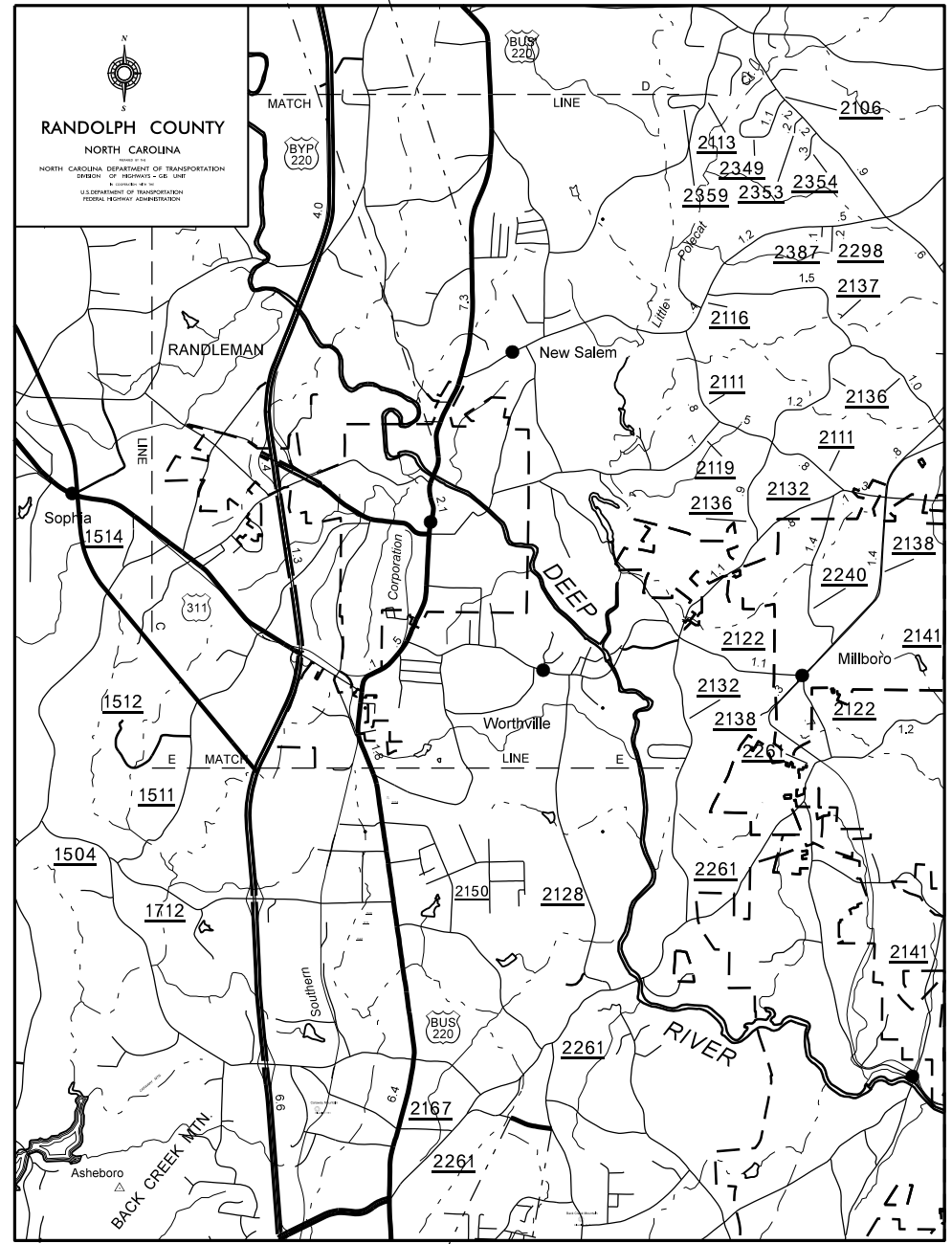
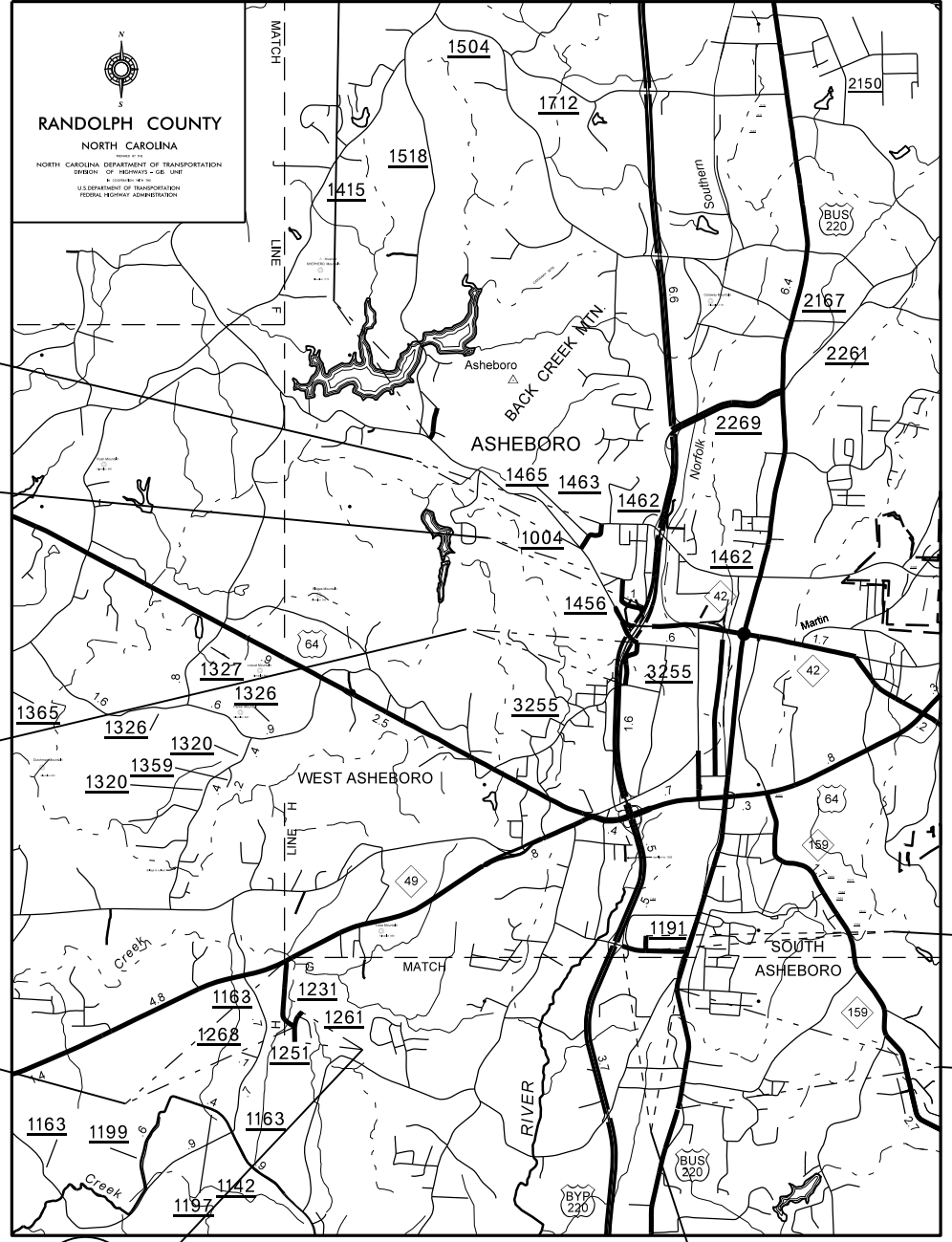

23

47

41

19

21

43

45

3

30

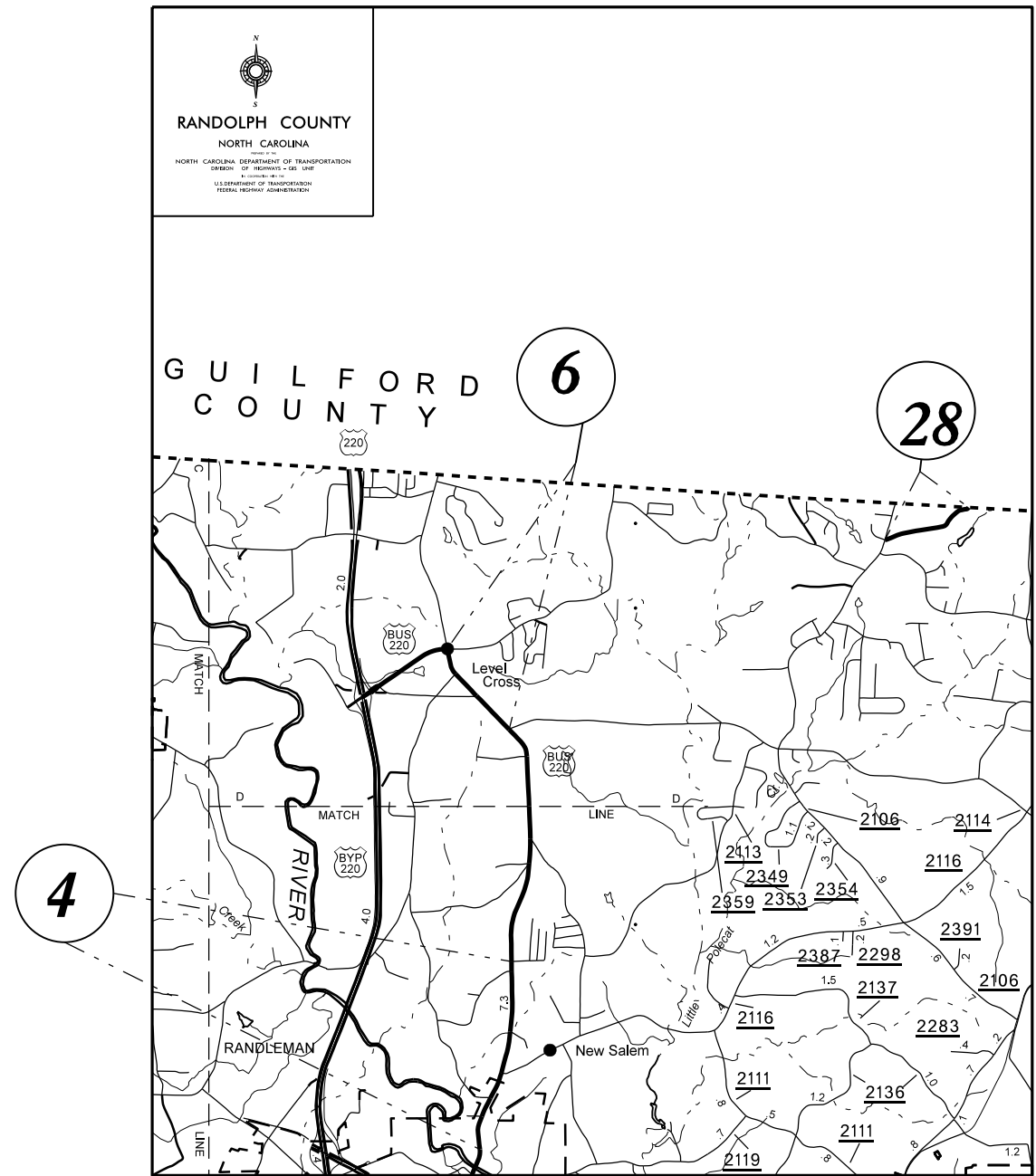
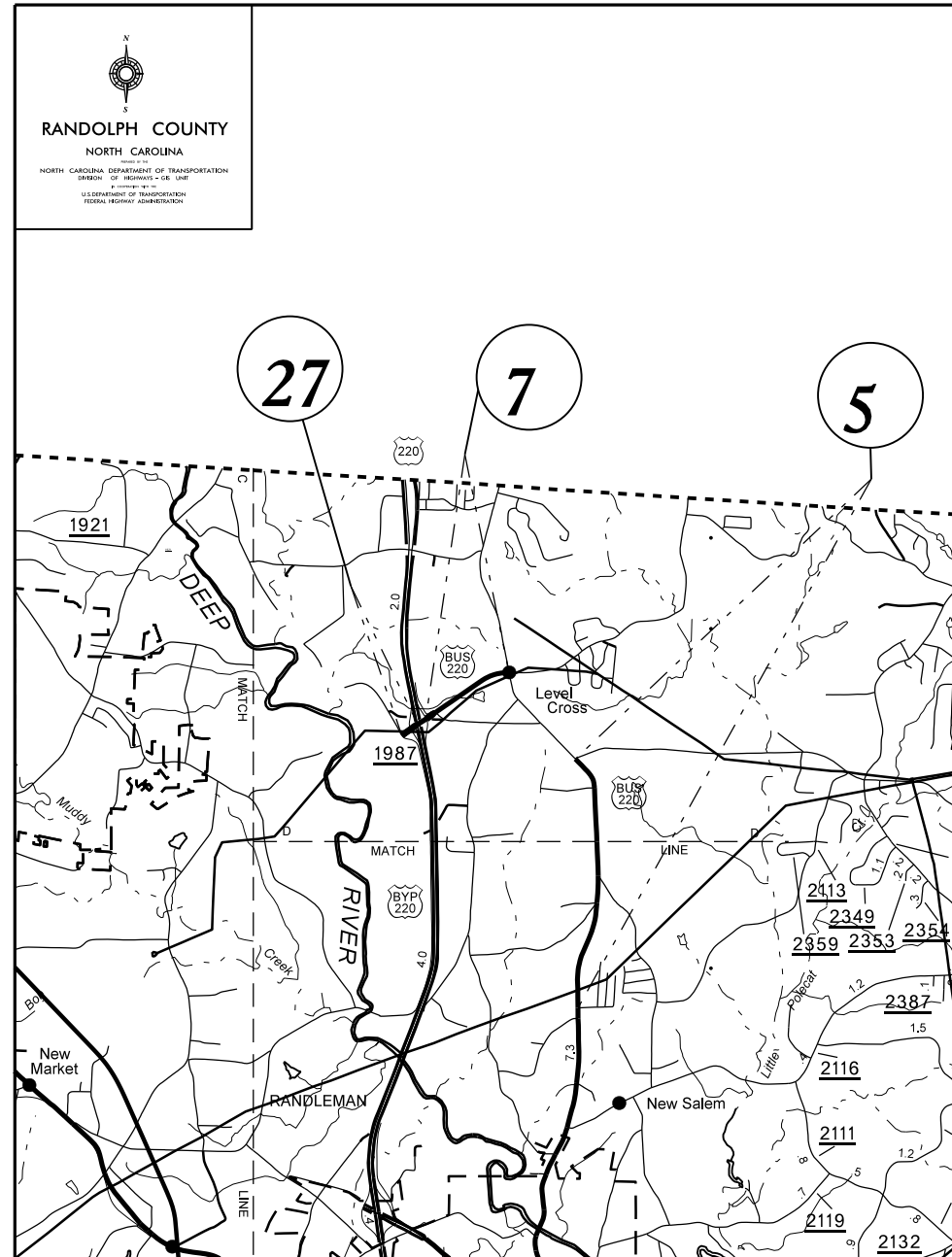

2018 MAR 20 08:49
 2018\N\Projects\2018\2018-Submittal\FY-2019_Randolph_Resurfacing_Overview_Map.dgn
 2018-03-20 08:49:49

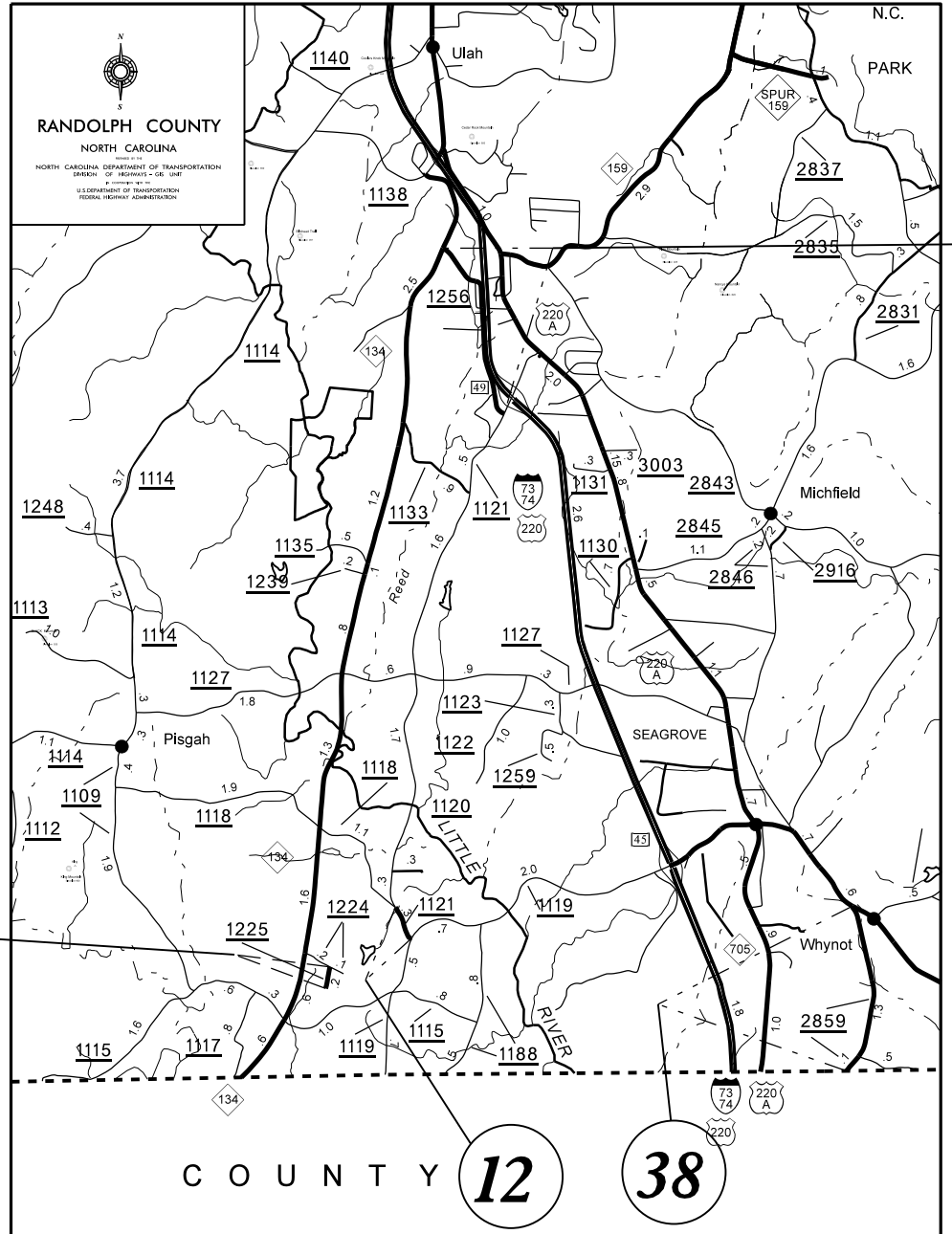
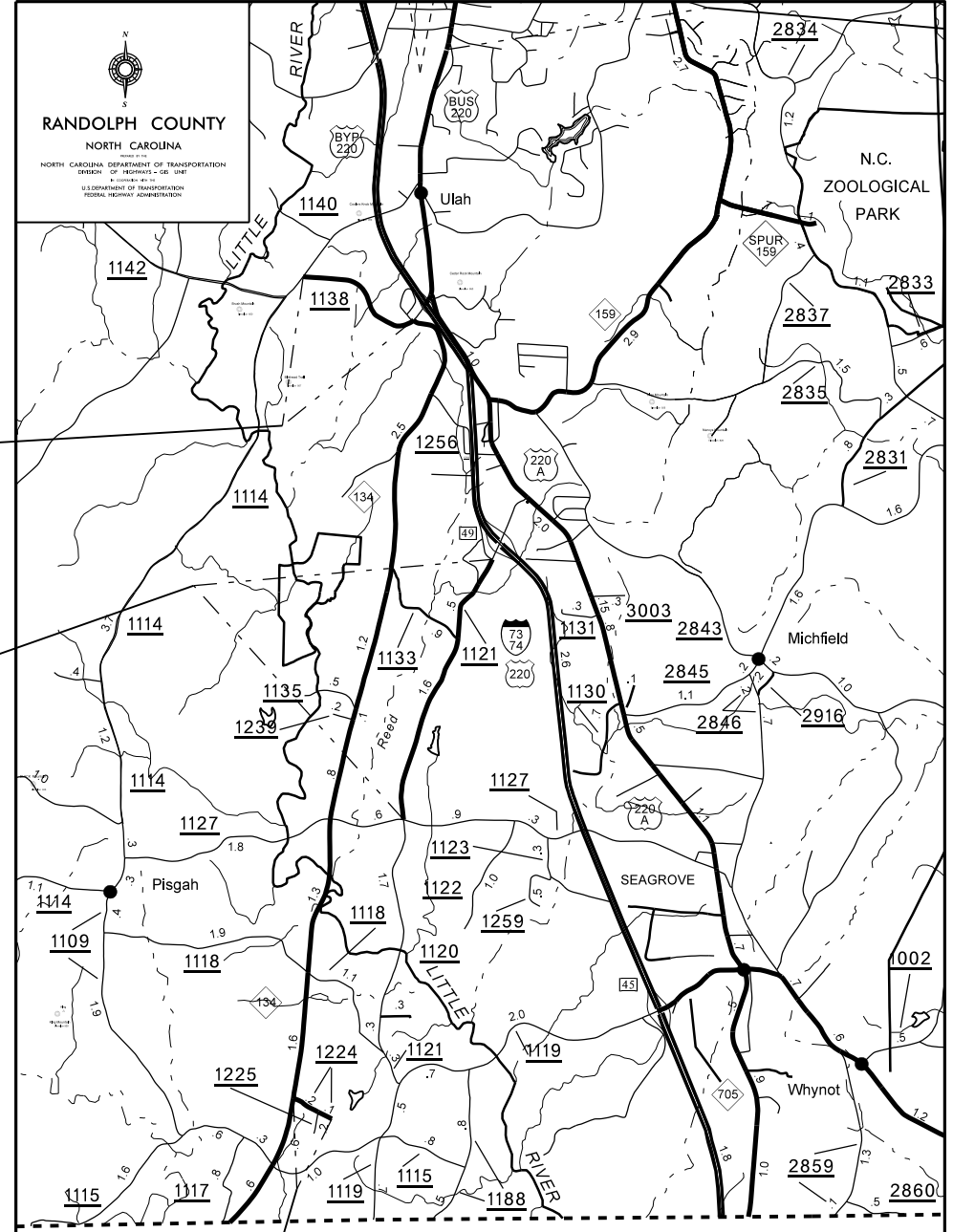

22

17

28 MAR 2018 09:49
 2018\N\Randolph_Mar-2018_Submittal\FY-2019_Randolph_Resurfacing_Overview_Map.dgn
 SAVES

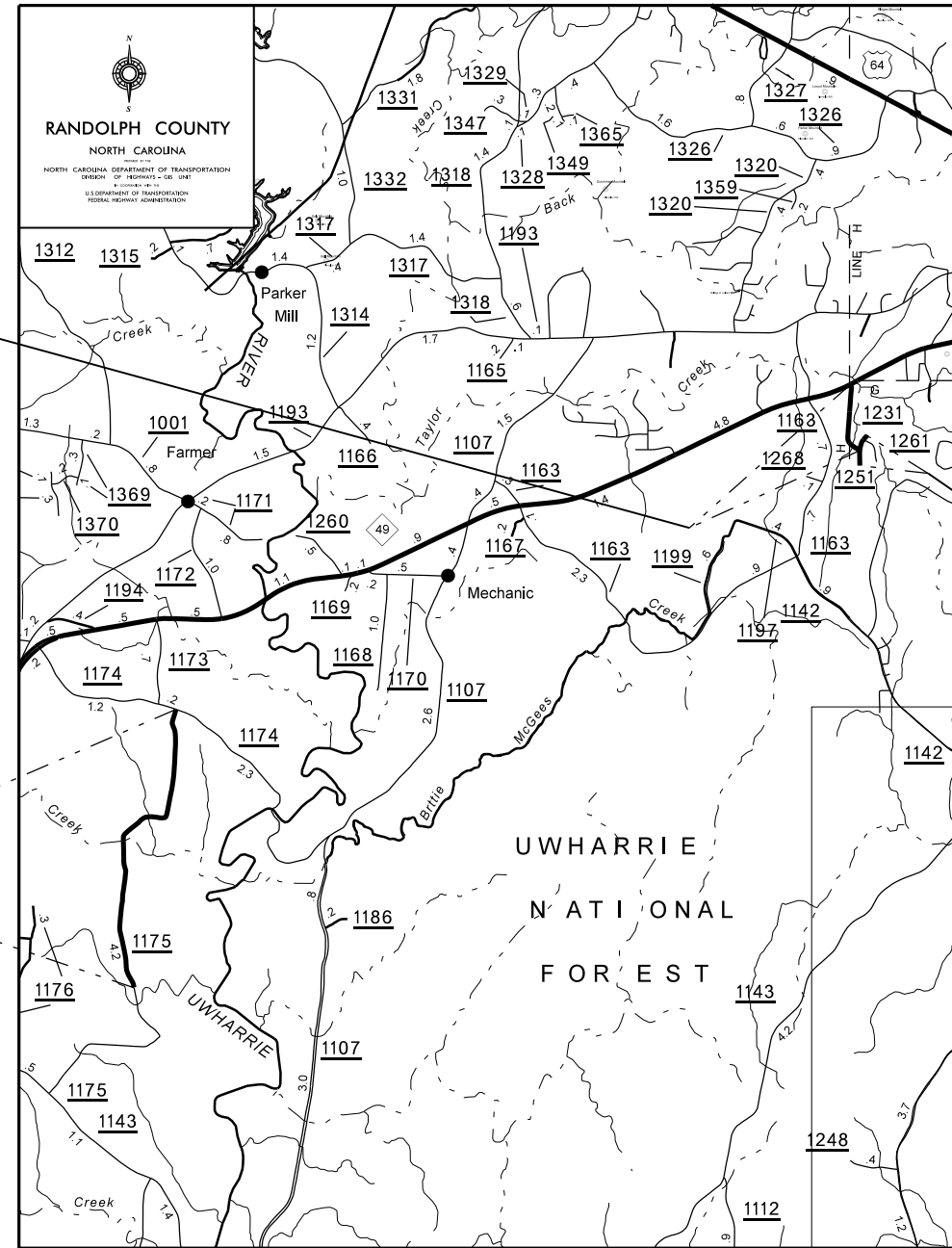
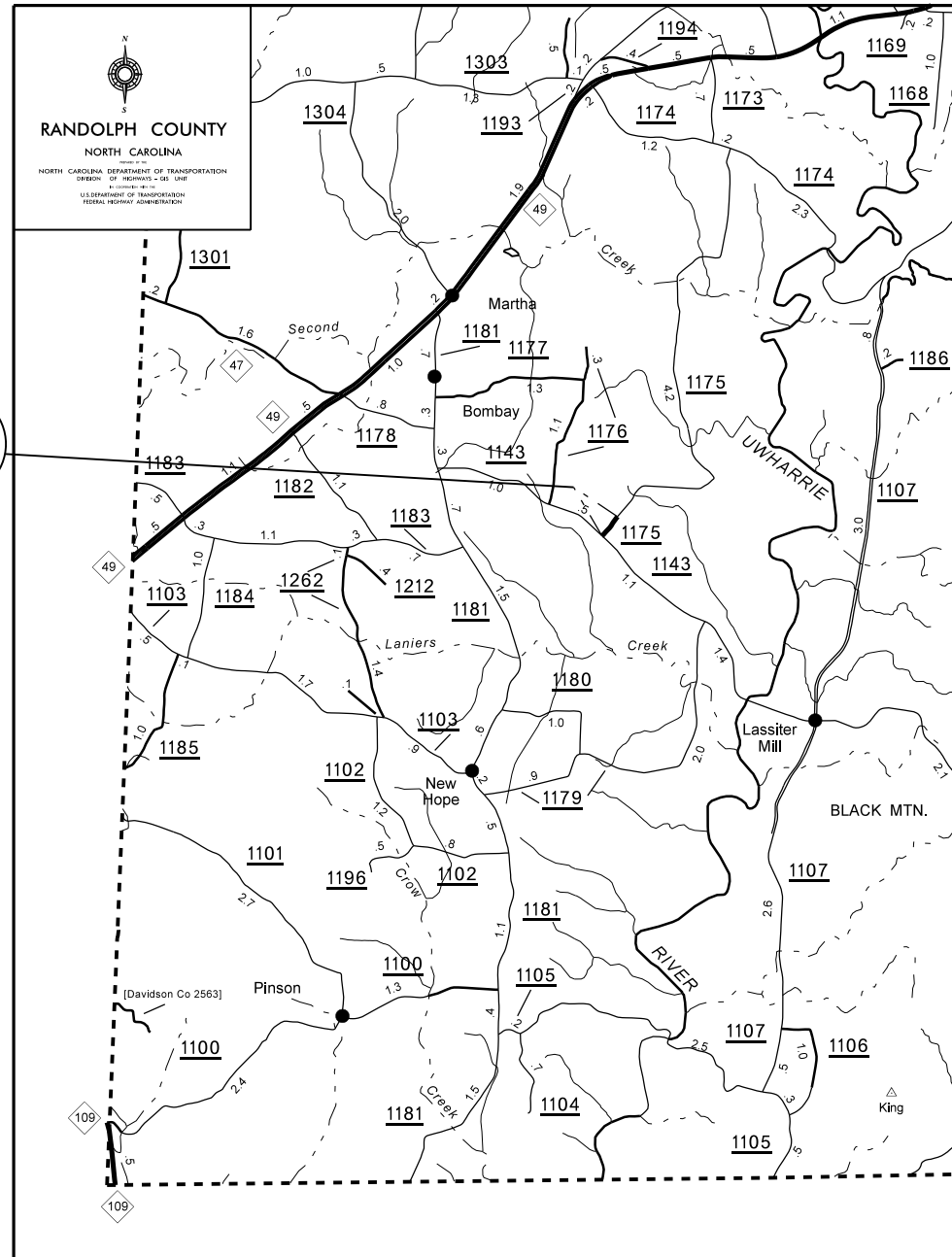

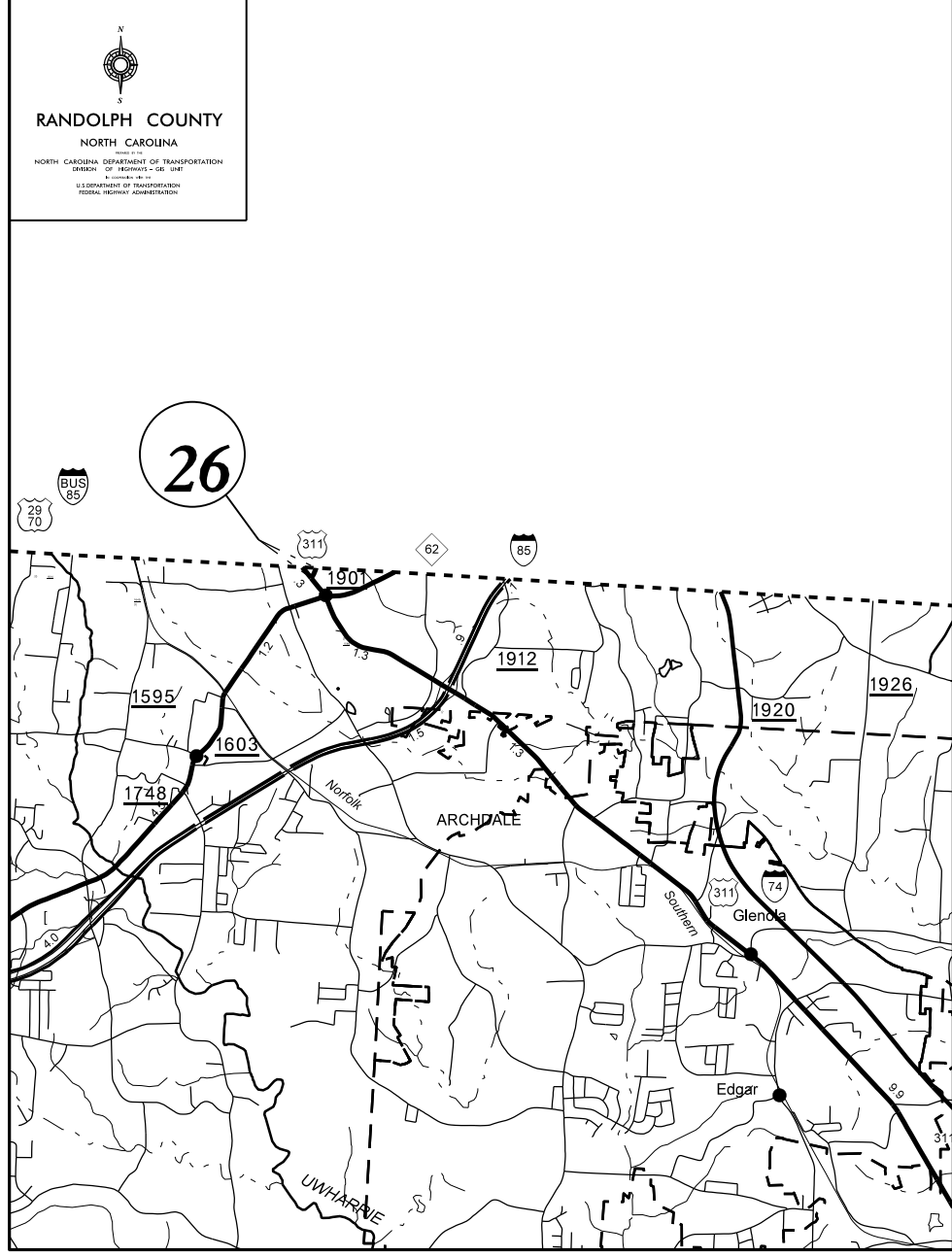
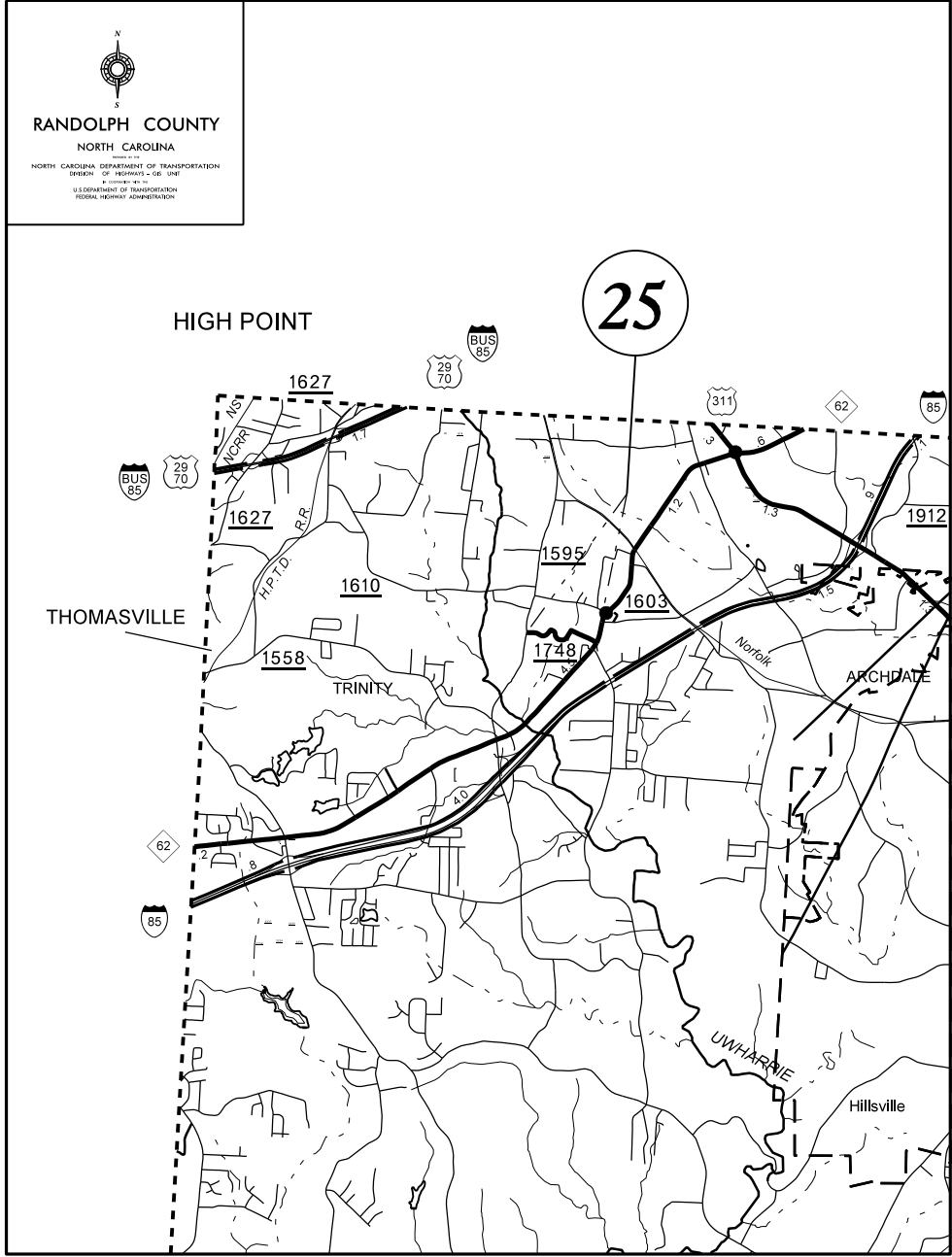

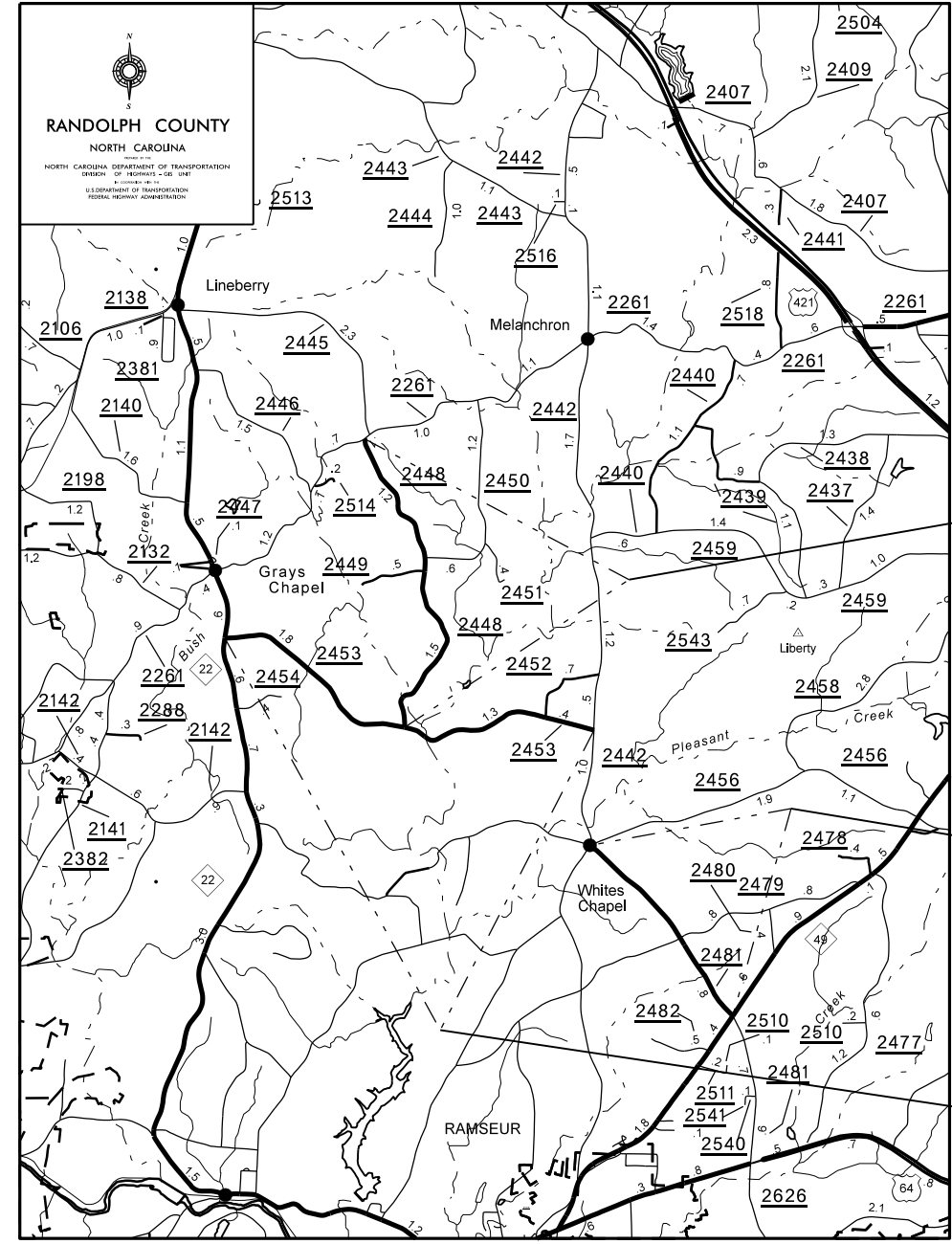
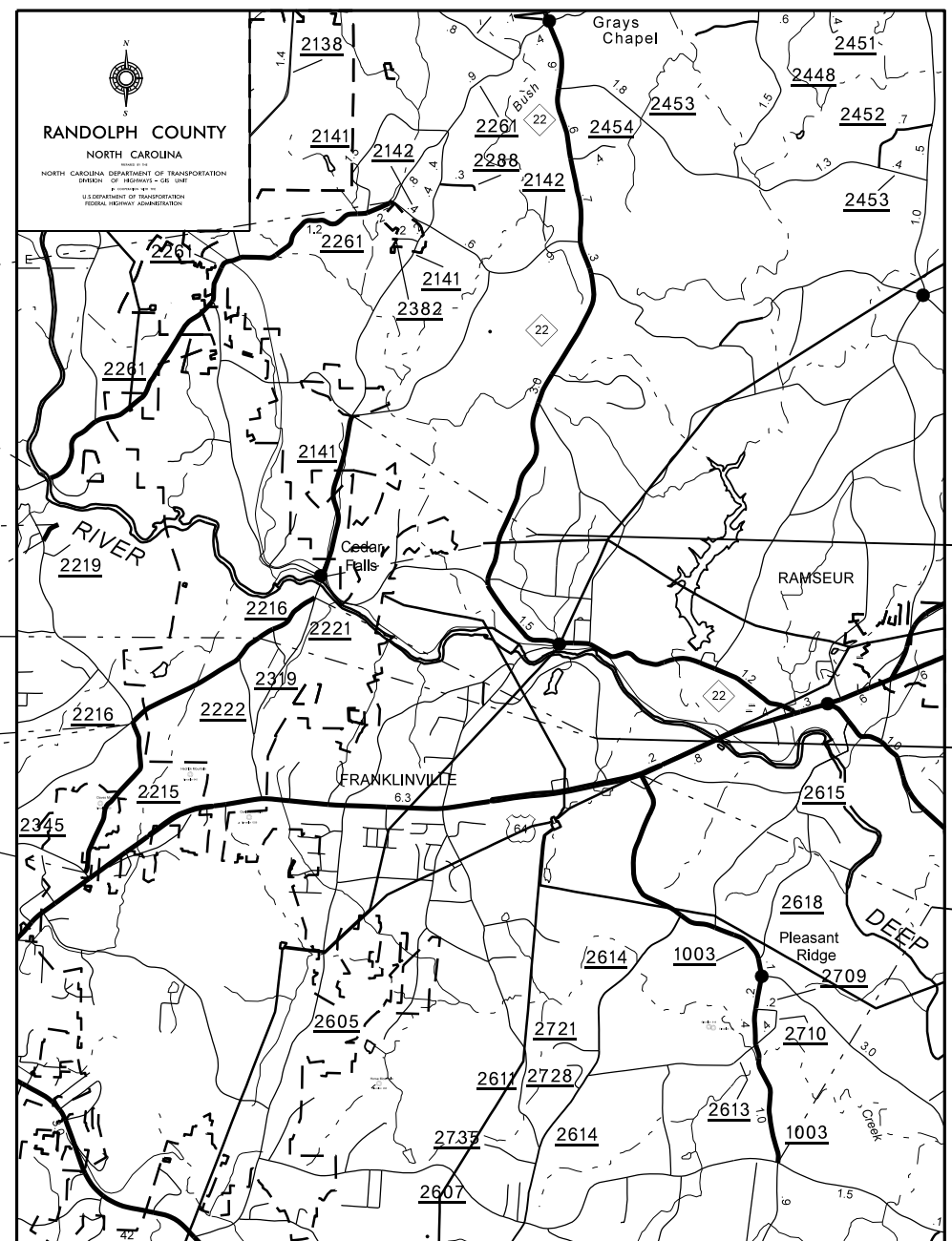

55

31

60

58

29

59

57

32

36

34

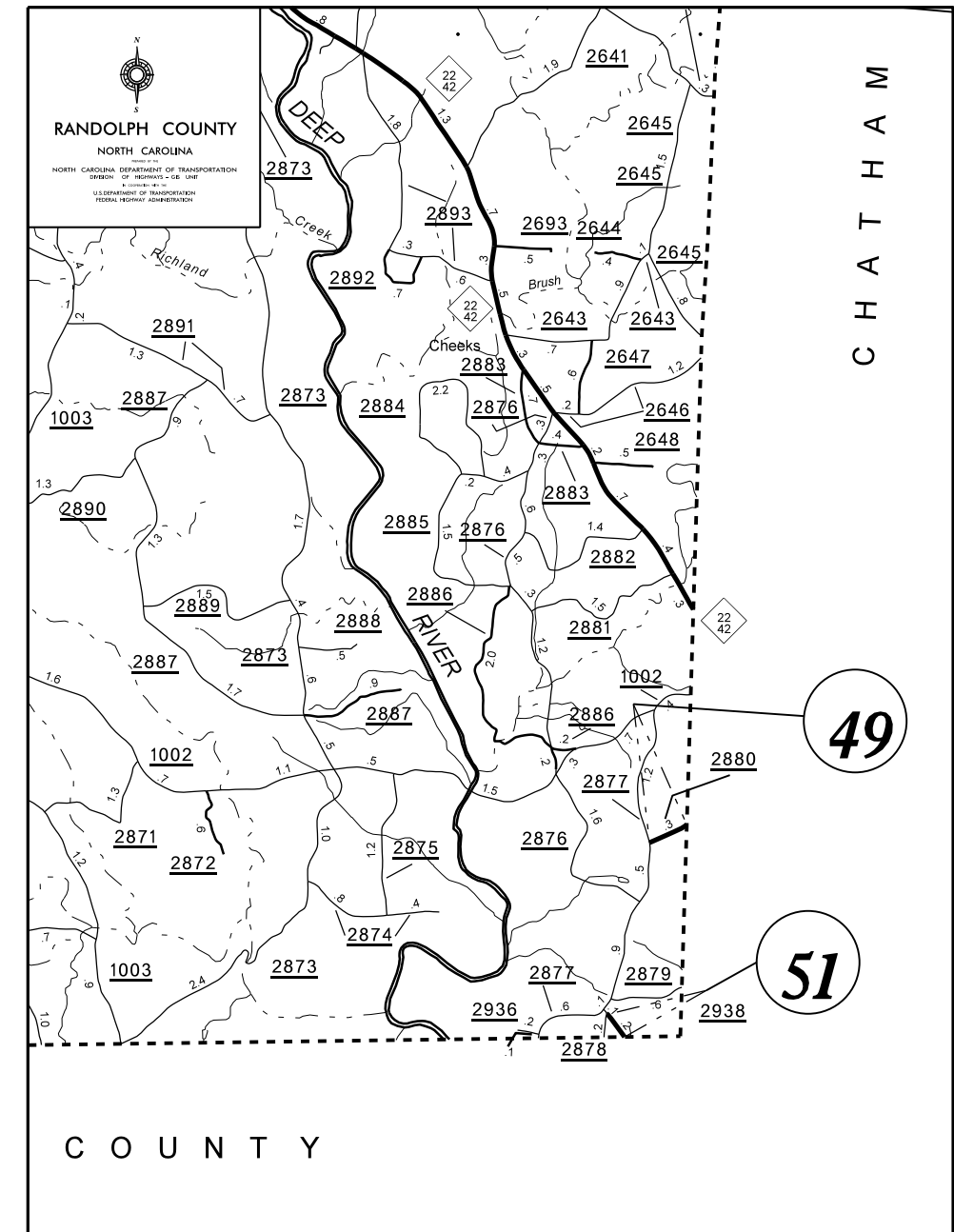
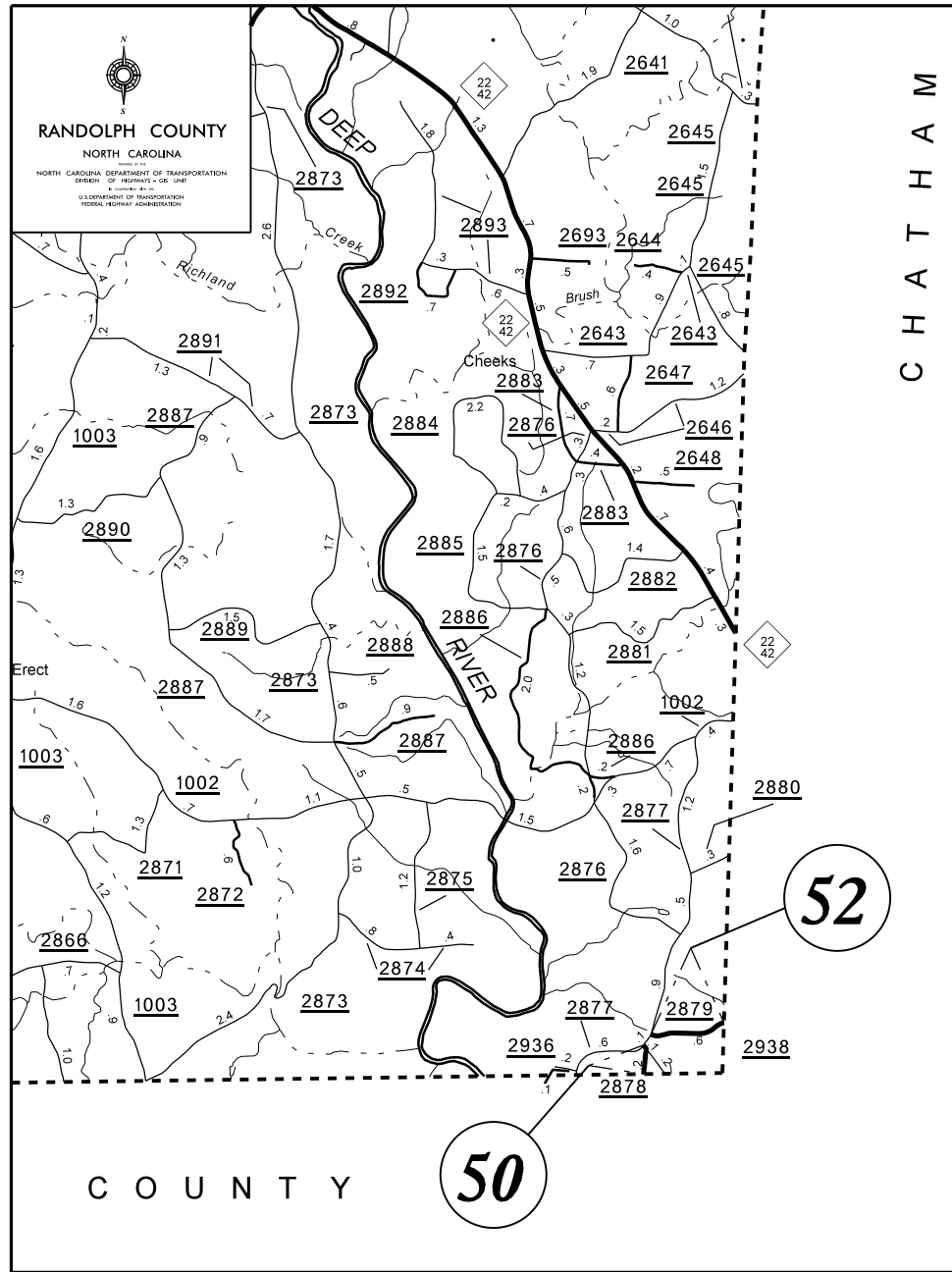

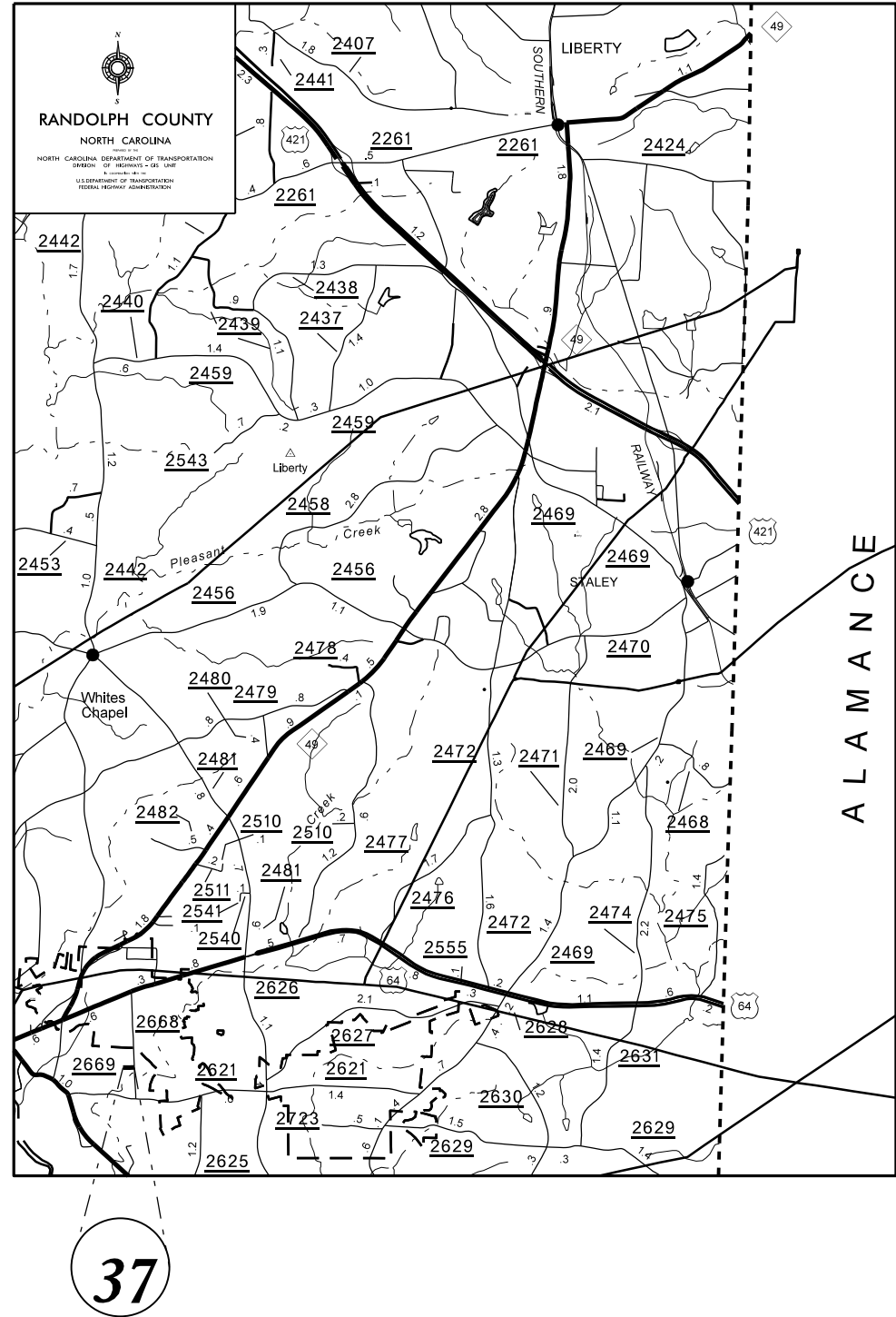
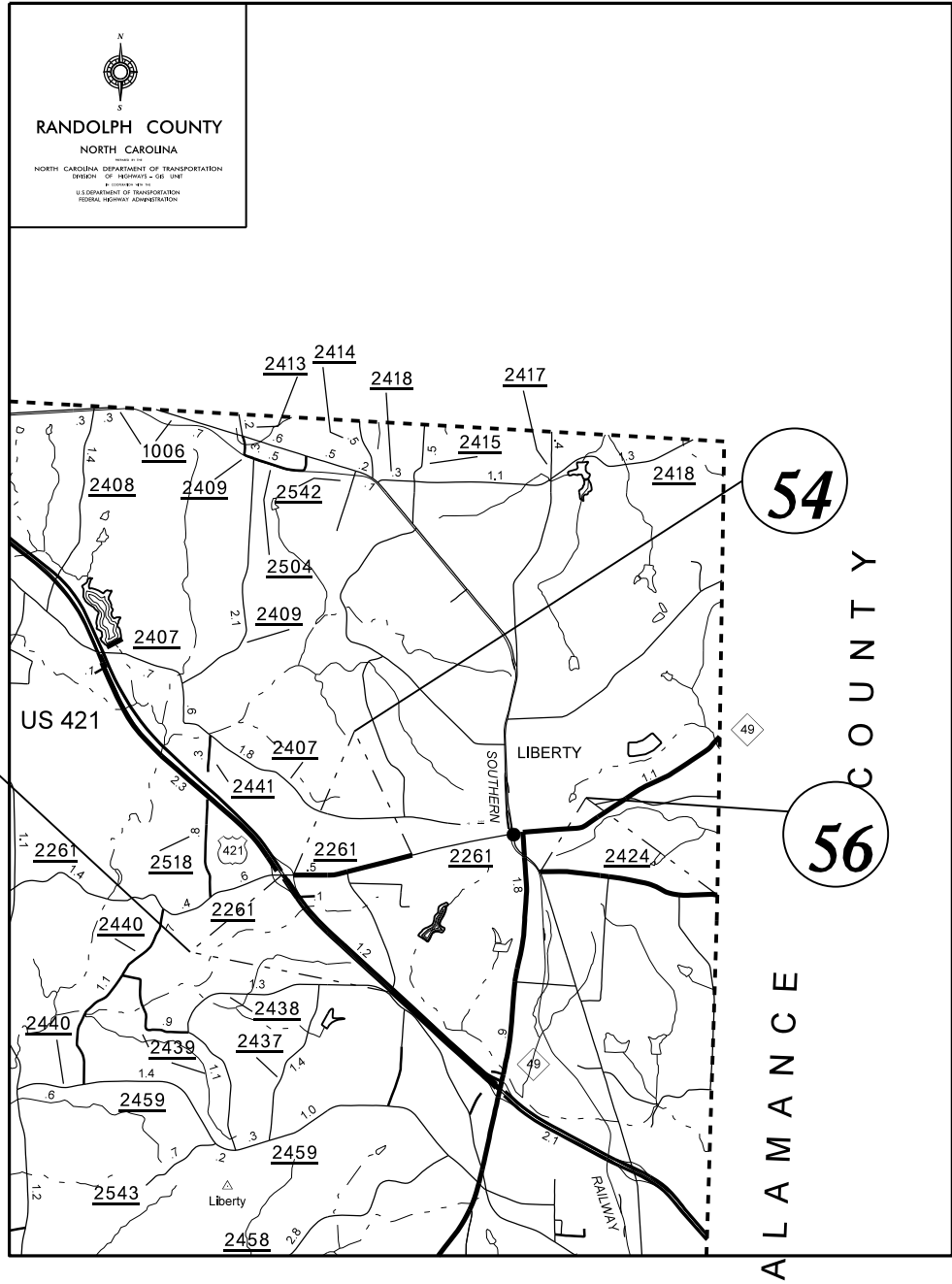

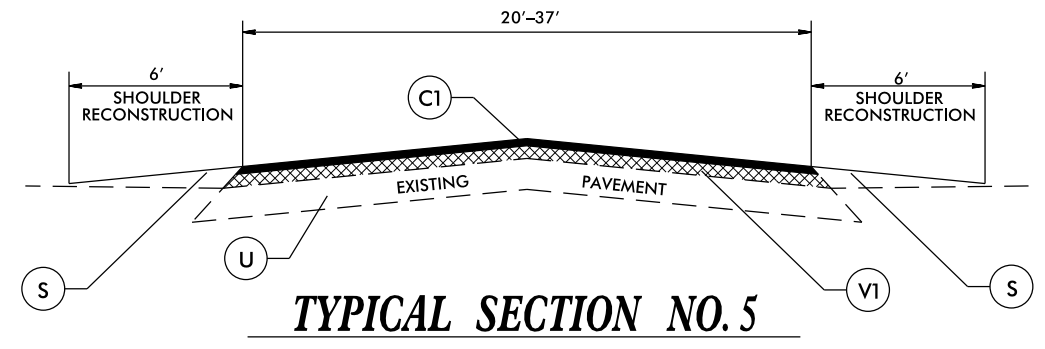
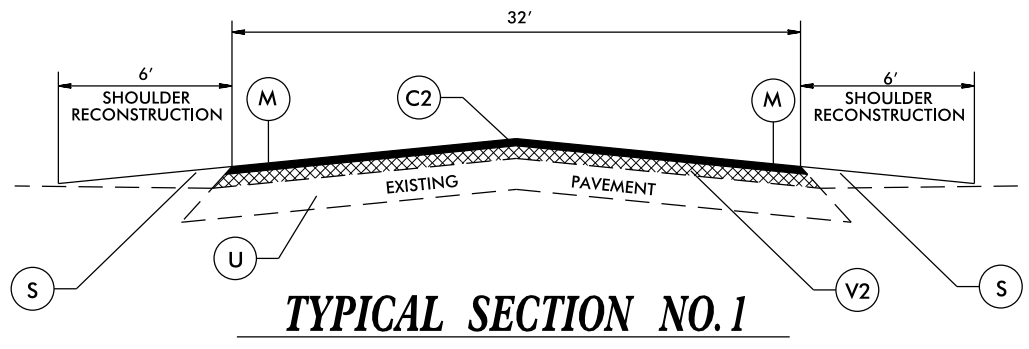

NOTE:
1. USE THIS TYPICAL ON MAPS 8 & 9 FOR RESURFACING RAMPS.

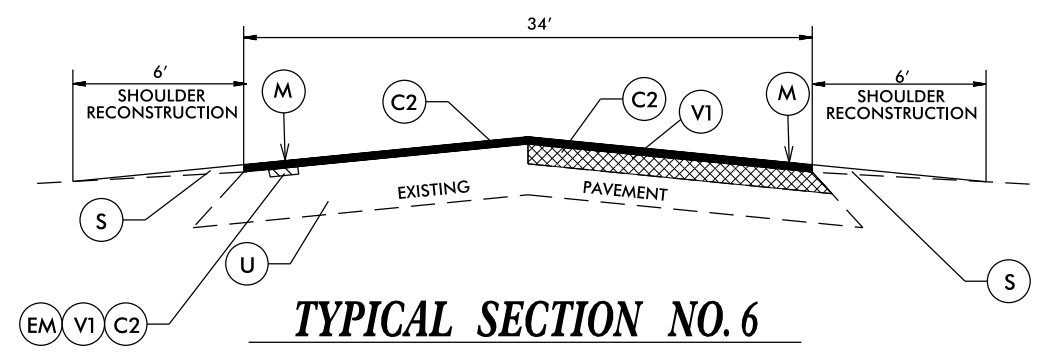
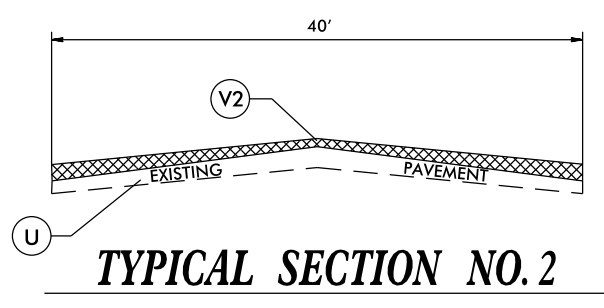

NOTE:
1. MILL 1.5" OUTSIDE LANE ONLY. MILL A SINGLE LANE & PAVE BACK BY THE END OF EACH DAY.
2. MILL 1.5" AND RESURFACE WITH 1.5" S9.5C. THE EXISTING RUMBLE STRIP TO MATCH EXISTING PAVEMENT LEVEL PRIOR TO RESURFACING ENTIRE ROADWAY AND PLACING NEW RUMBLE STRIPS.

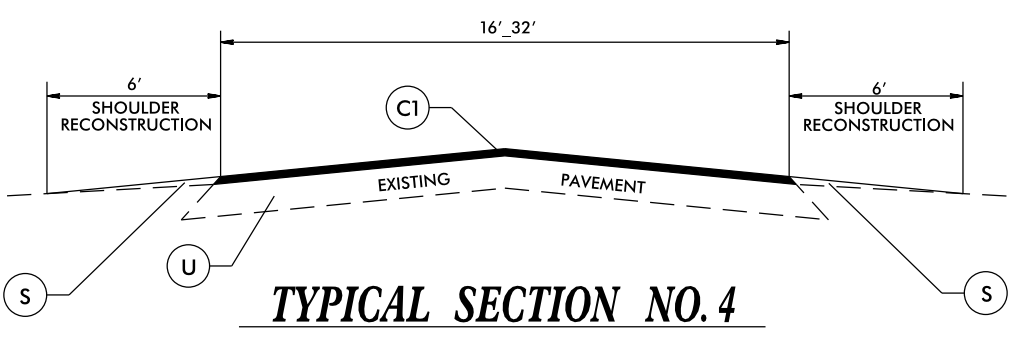
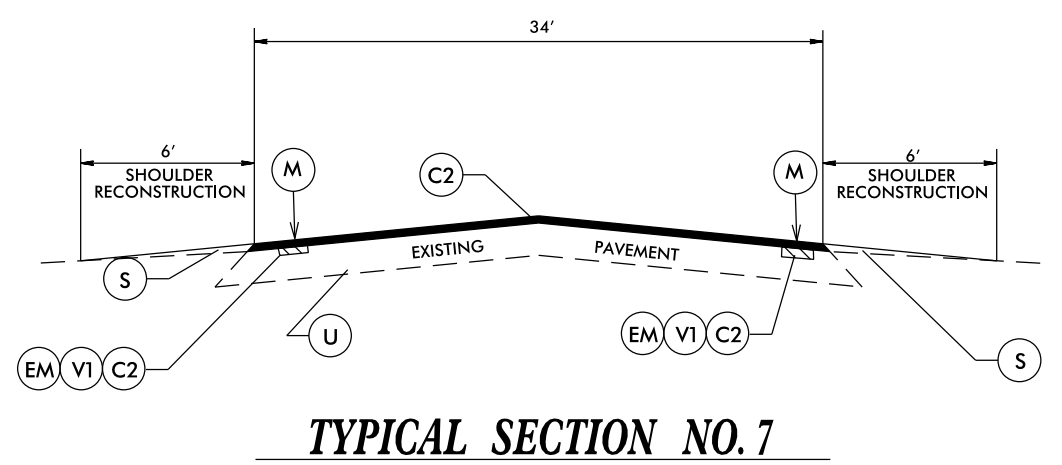
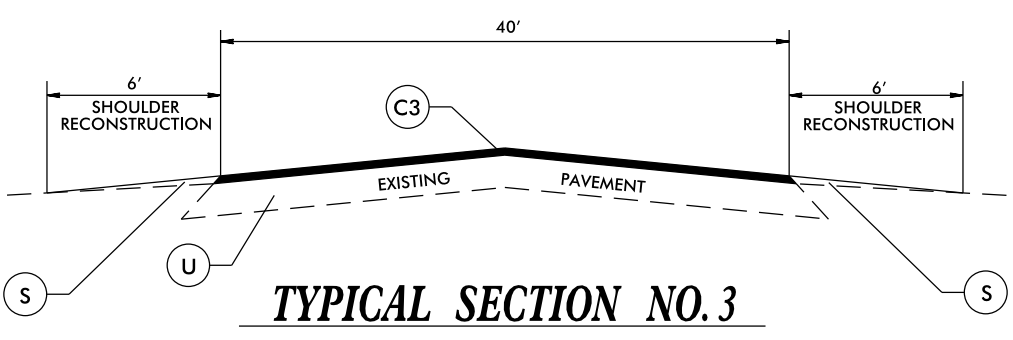

PAVEMENT SCHEDULE	
C1	PROP. APPROX. 1.5" ASPHALT CONCRETE SURFACE COURSE, TYPE S9.5B, AT AN AVERAGE RATE OF 165 LBS. PER SQ. YD.
C2	PROP. APPROX. 1.5" ASPHALT CONCRETE SURFACE COURSE, TYPE S9.5C, AT AN AVERAGE RATE OF 168 LBS. PER SQ. YD.
C3	PROP. APPROX. 2.0" ASPHALT CONCRETE SURFACE COURSE, TYPE S9.5B, AT AN AVERAGE RATE OF 220 LBS. PER SQ. YD.
C4	PROP. APPROX. 1" ASPHALT CONCRETE SURFACE COURSE, TYPE S4.75A, AT AN AVERAGE RATE OF 100 LBS. PER SQ. YD.
EM	EXIST. MILLED RUMBLE STRIPS
M	PROP. MILLED RUMBLE STRIPS
S	AGGREGATE SHOULDER BORROW
U	EXISTING PAVEMENT.
V1	MILLING 1.5" IN DEPTH
V2	MILLING 2.0" TO 1.5" AT CROWN
V3	MILLING 0.5" IN DEPTH

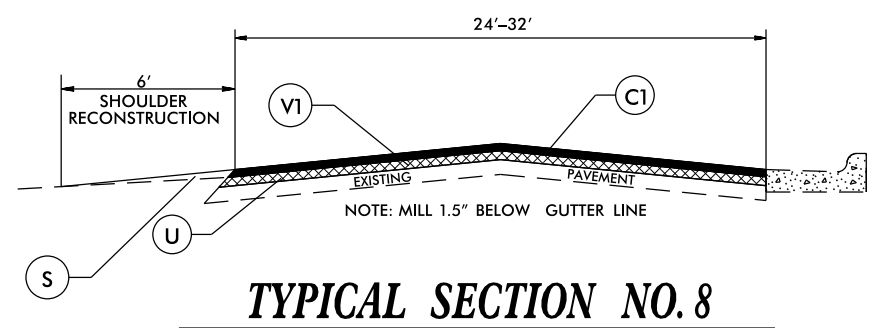

TYPICAL SECTION NO. 8

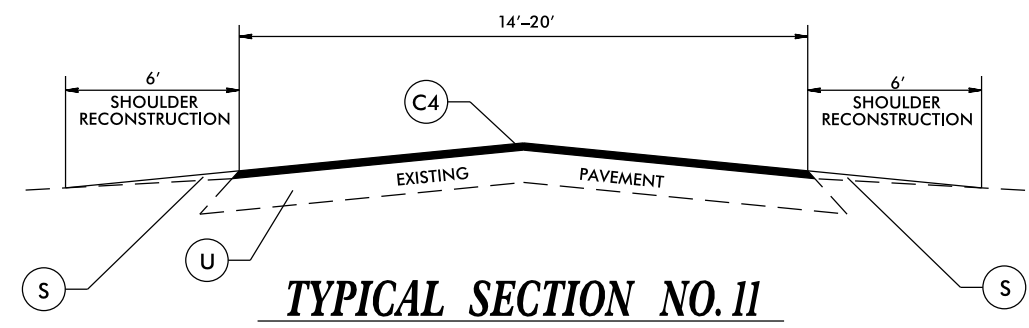

TYPICAL SECTION NO. 11

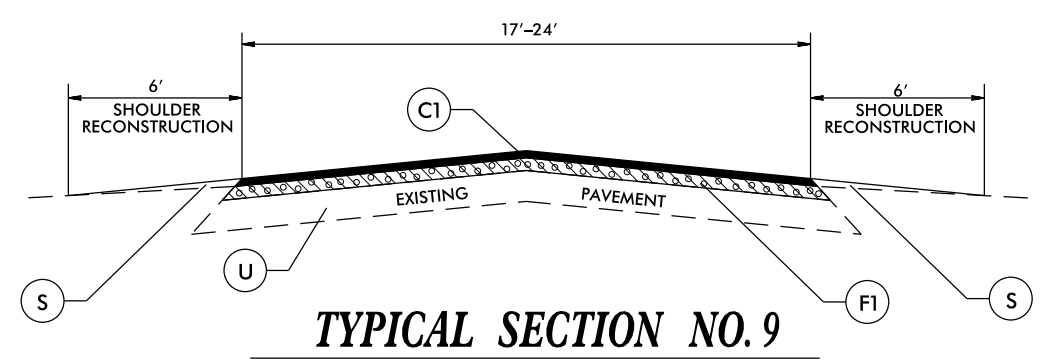

TYPICAL SECTION NO. 9

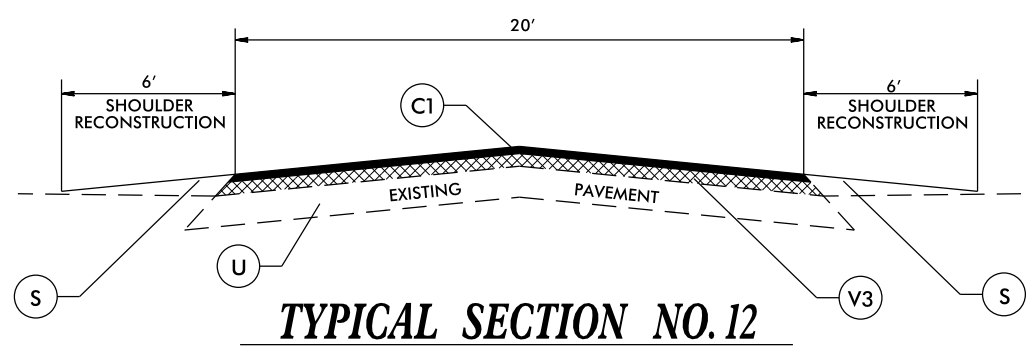

TYPICAL SECTION NO. 12

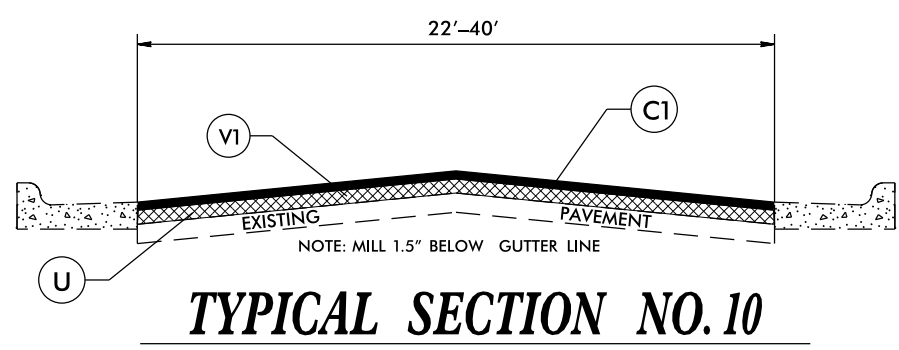

TYPICAL SECTION NO. 10

PAVEMENT SCHEDULE	
C1	PROP. APPROX. 1.5" ASPHALT CONCRETE SURFACE COURSE, TYPE S9.5B, AT AN AVERAGE RATE OF 165 LBS. PER SQ. YD.
C2	PROP. APPROX. 1.5" ASPHALT CONCRETE SURFACE COURSE, TYPE S9.5C, AT AN AVERAGE RATE OF 168 LBS. PER SQ. YD.
C3	PROP. APPROX. 2.0" ASPHALT CONCRETE SURFACE COURSE, TYPE S9.5B, AT AN AVERAGE RATE OF 220 LBS. PER SQ. YD.
C4	PROP. APPROX. 1.0" ASPHALT CONCRETE SURFACE COURSE, TYPE S4.75A, AT AN AVERAGE RATE OF 100 LBS. PER SQ. YD.
F1	PROPOSED ASPHALT SURFACE TREATMENT, MAT COAT WITH #67 STONE
M	PROP. MILLED RUMBLE STRIPS
S	AGGREGATE SHOULDER BORROW
U	EXISTING PAVEMENT.
V1	MILLING 1.5" IN DEPTH
V2	MILLING 2.0" TO 1.5" AT CROWN
V3	MILLING 0.5" IN DEPTH

040397
15-MAR-2018 16:29
M:\JULIAN\2018\18-001\18-001.dgn
15-MAR-2018 16:29
M:\JULIAN\2018\18-001\18-001.dgn

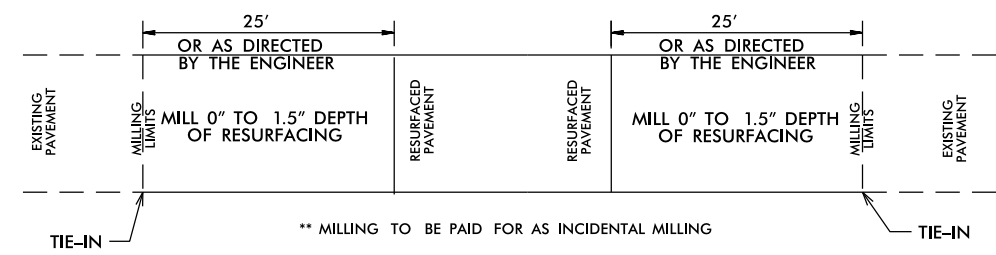
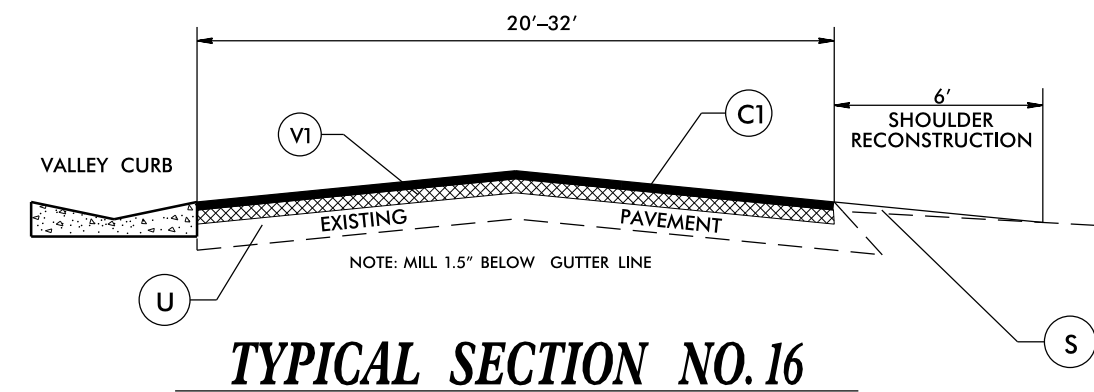
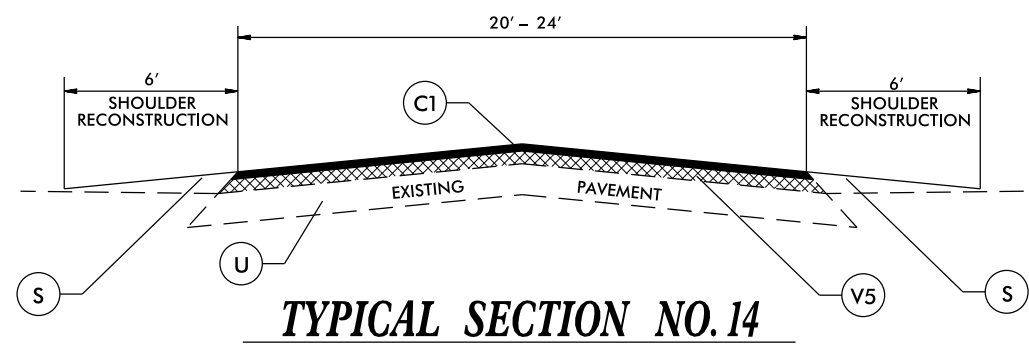
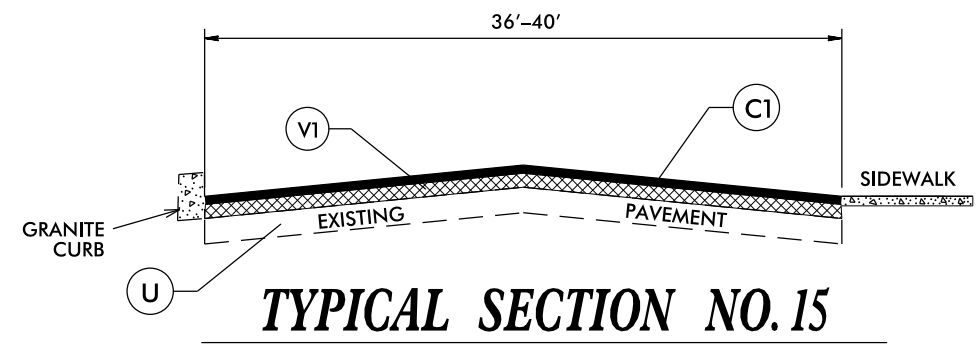
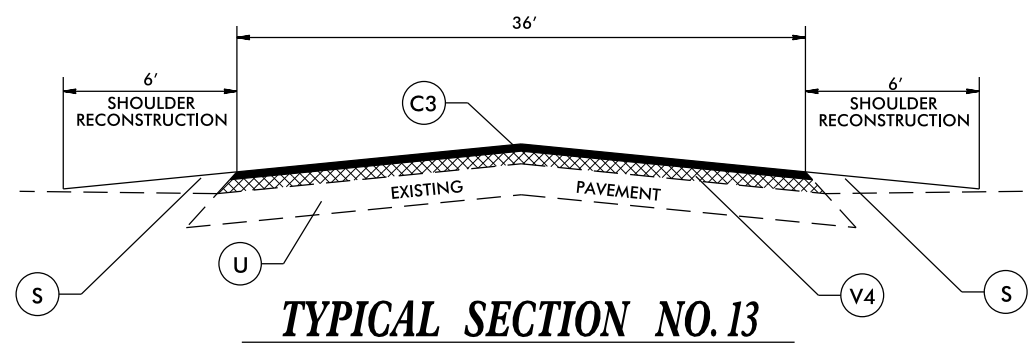

PAVEMENT SCHEDULE	
C1	PROP. APPROX. 1.5" ASPHALT CONCRETE SURFACE COURSE, TYPE S9.5B, AT AN AVERAGE RATE OF 165 LBS. PER SQ. YD.
C2	PROP. APPROX. 1.5" ASPHALT CONCRETE SURFACE COURSE, TYPE S9.5C, AT AN AVERAGE RATE OF 168 LBS. PER SQ. YD.
C3	PROP. APPROX. 2.0" ASPHALT CONCRETE SURFACE COURSE, TYPE S9.5B, AT AN AVERAGE RATE OF 220 LBS. PER SQ. YD.
C4	PROP. APPROX. 1.0" ASPHALT CONCRETE SURFACE COURSE, TYPE S4.75A, AT AN AVERAGE RATE OF 100 LBS. PER SQ. YD.
F1	PROPOSED ASPHALT SURFACE TREATMENT, MAT COAT WITH #67 STONE
M	PROP. MILLED RUMBLE STRIPS
S	AGGREGATE SHOULDER BORROW
U	EXISTING PAVEMENT.
V1	MILLING 1.5" IN DEPTH
V2	MILLING 2.0" TO 1.5" AT CROWN
V3	MILLING 0.50" IN DEPTH
V4	MILLING 2.0" IN DEPTH
V5	MILLING 1.0" IN DEPTH

040397
 15-MAR-2018 16:29
 M:\JUL-2018\18-Submittal\FY-2019_Rendolph_typical.dgn

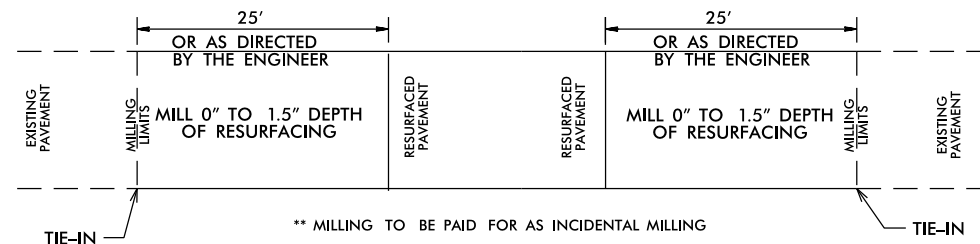
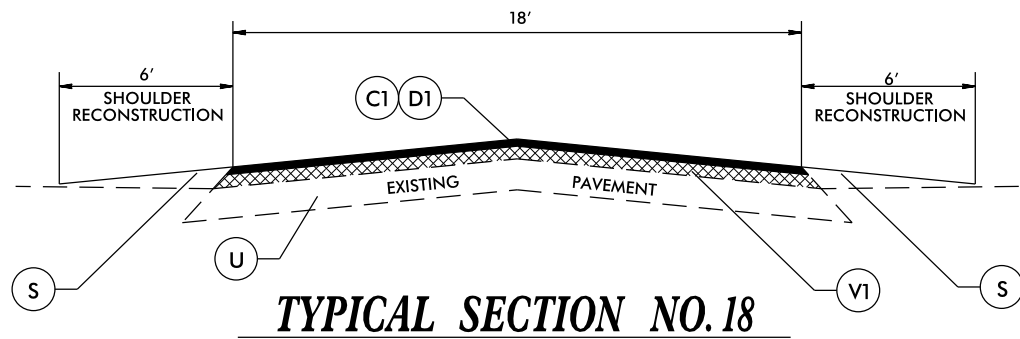
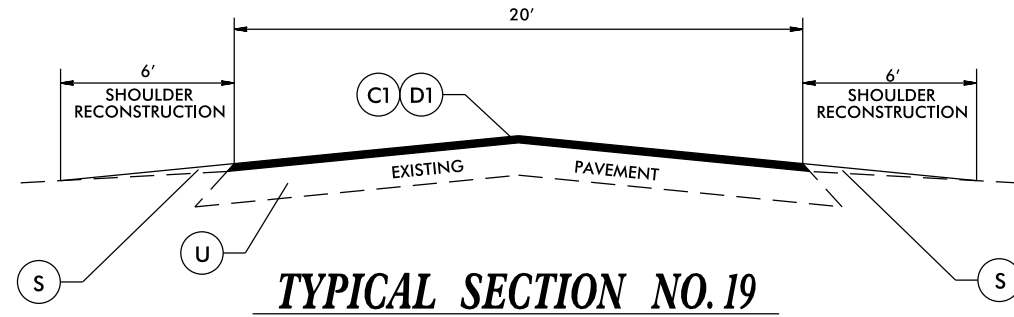
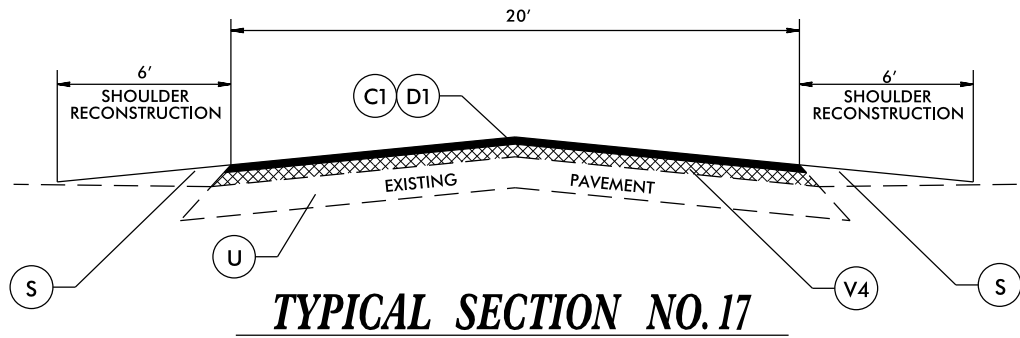

PAVEMENT SCHEDULE	
C1	PROP. APPROX. 1.5" ASPHALT CONCRETE SURFACE COURSE, TYPE S9.5B, AT AN AVERAGE RATE OF 165 LBS. PER SQ. YD.
C2	PROP. APPROX. 1.5" ASPHALT CONCRETE SURFACE COURSE, TYPE S9.5C, AT AN AVERAGE RATE OF 168 LBS. PER SQ. YD.
C3	PROP. APPROX. 2.0" ASPHALT CONCRETE SURFACE COURSE, TYPE S9.5B, AT AN AVERAGE RATE OF 220 LBS. PER SQ. YD.
C4	PROP. APPROX. 1.0" ASPHALT CONCRETE SURFACE COURSE, TYPE S4.75A, AT AN AVERAGE RATE OF 100 LBS. PER SQ. YD.
D1	PROP. APPROX. 2.5" ASPHALT CONCRETE INTERMEDIATE COURSE, TYPE I19.0C, AT AN AVERAGE RATE OF 285 LBS. PER SQ. YD.
F1	PROPOSED ASPHALT SURFACE TREATMENT, MAT COAT WITH #67 STONE
M	PROP. MILLED RUMBLE STRIPS
S	AGGREGATE SHOULDER BORROW
U	EXISTING PAVEMENT.
V1	MILLING 1.5" IN DEPTH
V2	MILLING 2.0" TO 1.5" AT CROWN
V3	MILLING 0.50" IN DEPTH
V4	MILLING 2.0" IN DEPTH
V5	MILLING 1.0" IN DEPTH

040397
 19-APR-2018 16:45
 M:\2018-Projects\2018-Submittals\FY_2019_Removal\ph_typical.dgn

BRIDGE TYPICALS

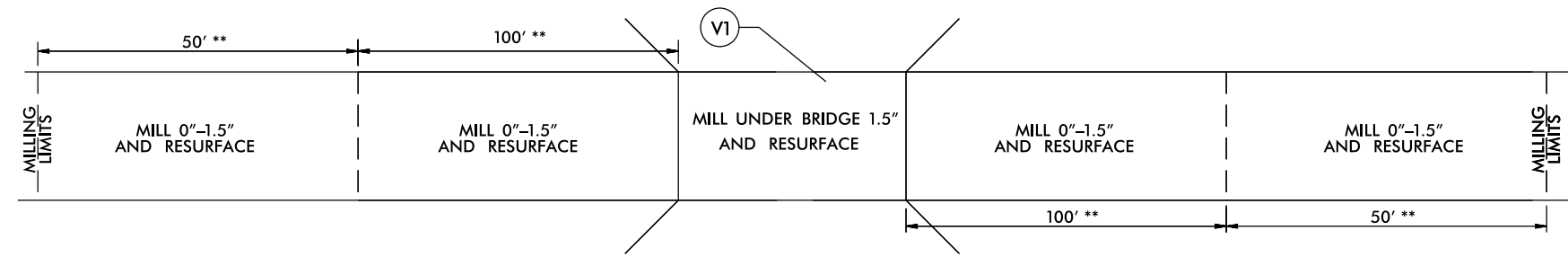

BRIDGE DRAWING FOR HWY# US 421 NB
 USE FOR MAP# 8, #42
 USE FOR BRIDGE# 142, # 203 AND # 182

* MILL TO MAINTAIN VERTICAL CLEARANCE
 ** MILLING SHALL BE PAID FOR UNDER INCIDENTAL MILLING

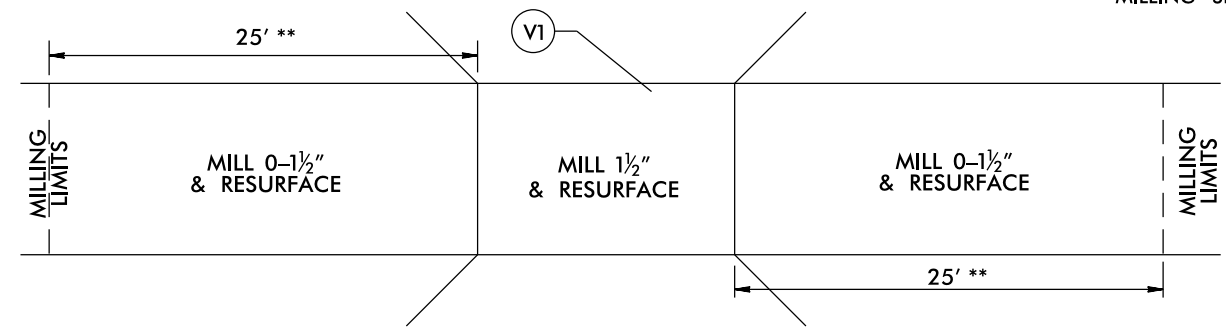

BRIDGE DRAWING
 USE FOR MAP #10, #15, #32, AND #34
 USE FOR BRIDGE# 15, #342, #152, AND #151
 ** MILLING SHALL BE PAID FOR UNDER INCIDENTAL MILLING

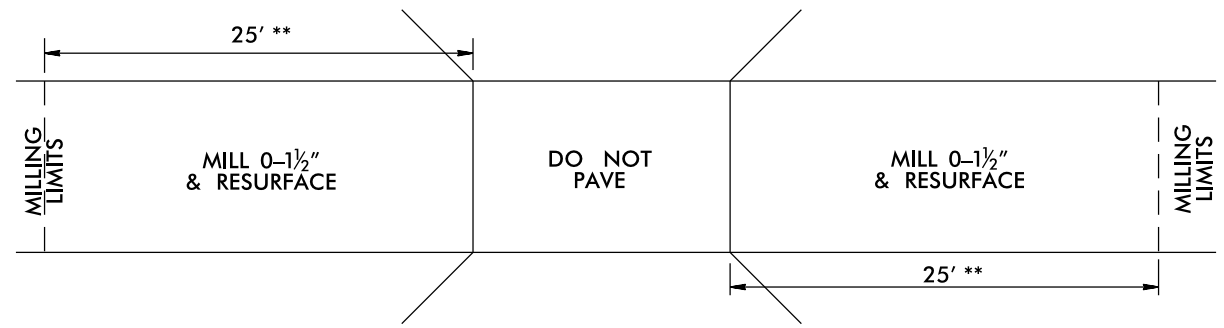

BRIDGE DRAWING
 USE FOR MAP #10,
 USE FOR BRIDGE #137
 ** MILLING SHALL BE PAID FOR UNDER INCIDENTAL MILLING

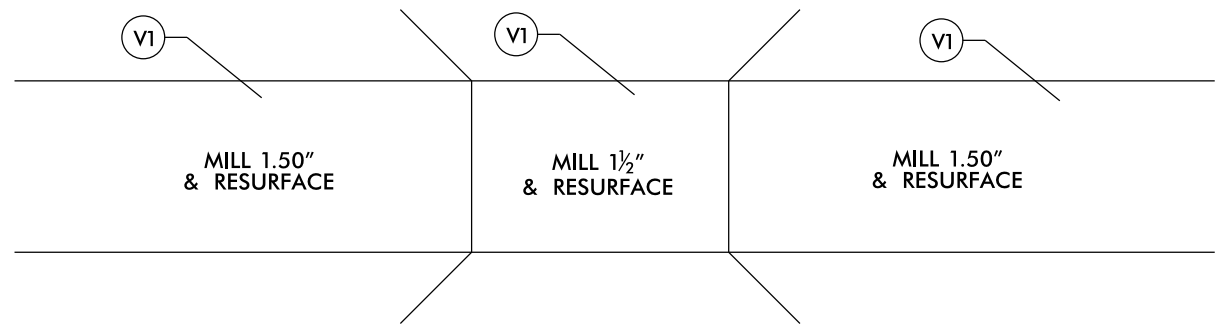

BRIDGE DRAWING
 USE FOR MAP #41, #48 AND #55
 USE FOR BRIDGE# 38, #375, AND #435

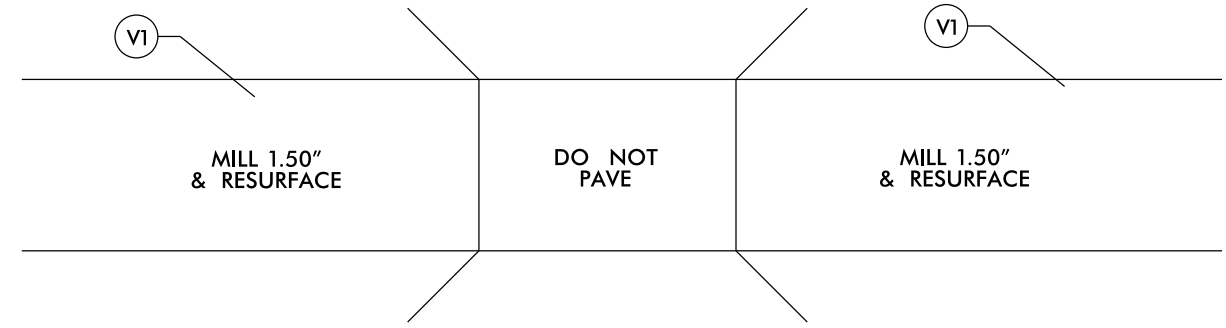

BRIDGE DRAWING
 USE FOR MAP #55 AND #7
 USE FOR BRIDGE# 434 AND #238

PAVEMENT SCHEDULE	
V1	MILLING 1.5" IN DEPTH

JOINT REPAIR

JOINT SCHEDULE	
MAP	# OF JOINTS
2	2
3	3
38	22

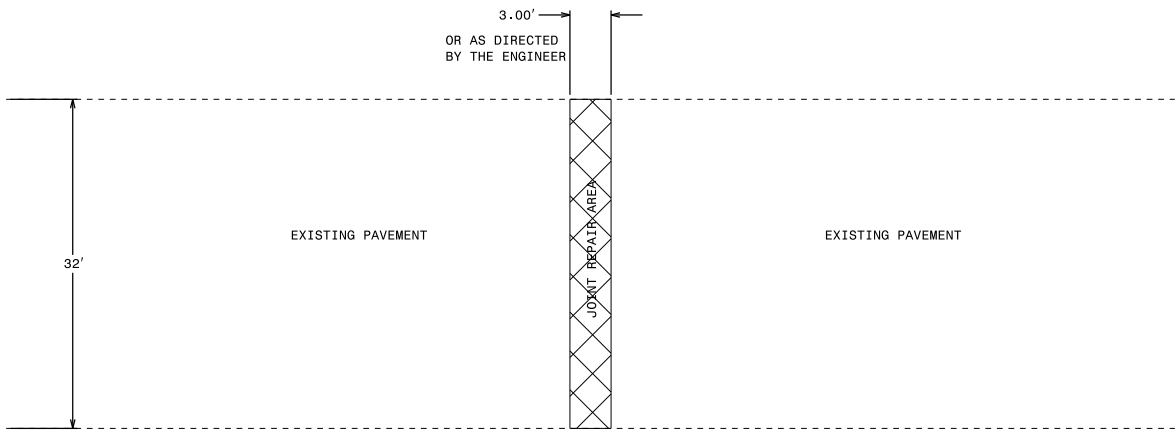

CONTRACTOR SHALL COORDINATE WITH RESIDENT ENGINEER'S OFFICE FOR LOCATION OF JOINTS TO BE REPAIRED.

CROSS-SECTION

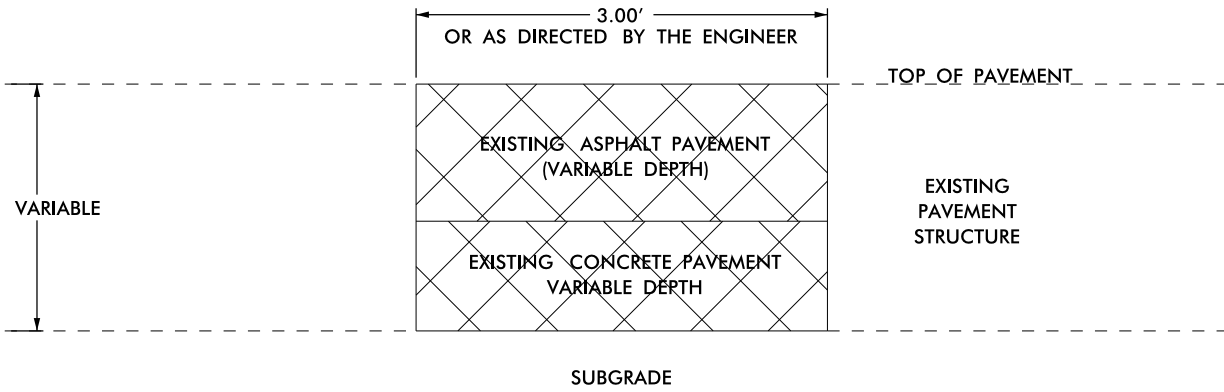

NOTE:
REMOVE ASPHALT AND CONCRETE AT JOINT LOCATIONS AS DIRECTED BY THE ENGINEER (BY SAWING CLEAN JOINTS). REMOVE A TOTAL WIDTH OF 3' (APPROX. 1.5' EACH SIDE OF JOINT). REMOVE AND REPLACE WITH ASPHALT CONCRETE BASE COURSE, TYPE B25.0C. THERE WILL BE NO DIRECT PAY FOR THIS WORK AS IT WILL BE CONSIDERED INCIDENTAL TO TO THE LINE ITEM, JOINT REPAIR (TONNAGE)

DETAILS OF PATCHING EXISTING PAVEMENT PRIOR TO RESURFACING DETAIL

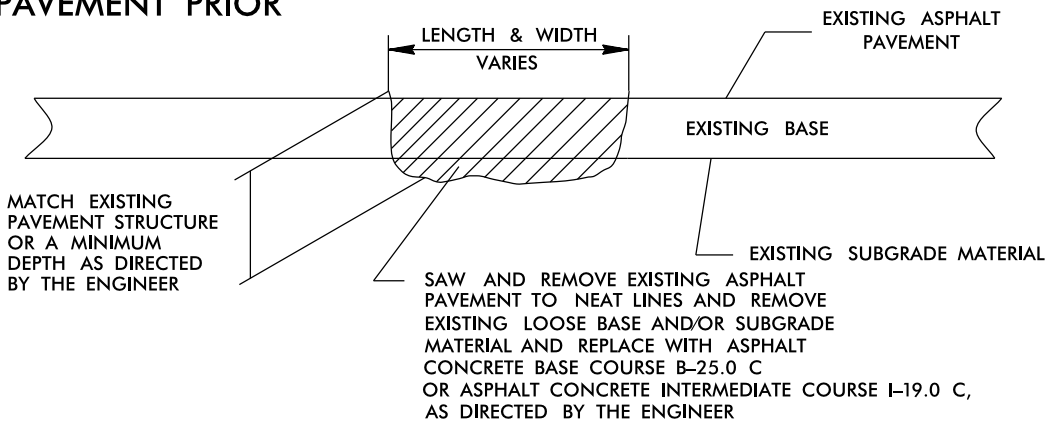

15-MAR-2018 16:29
M:\JUL-2018-11-15-2018-Submittal\FY-2019-Rendol\ph_tjpt\cals.dgn

SIGNING FOR ASPHALT SURFACE TREATMENT

LEGEND

- ▷ PORTABLE SIGN
- ┌ STATIONARY SIGN
- ← DIRECTION OF TRAFFIC FLOW

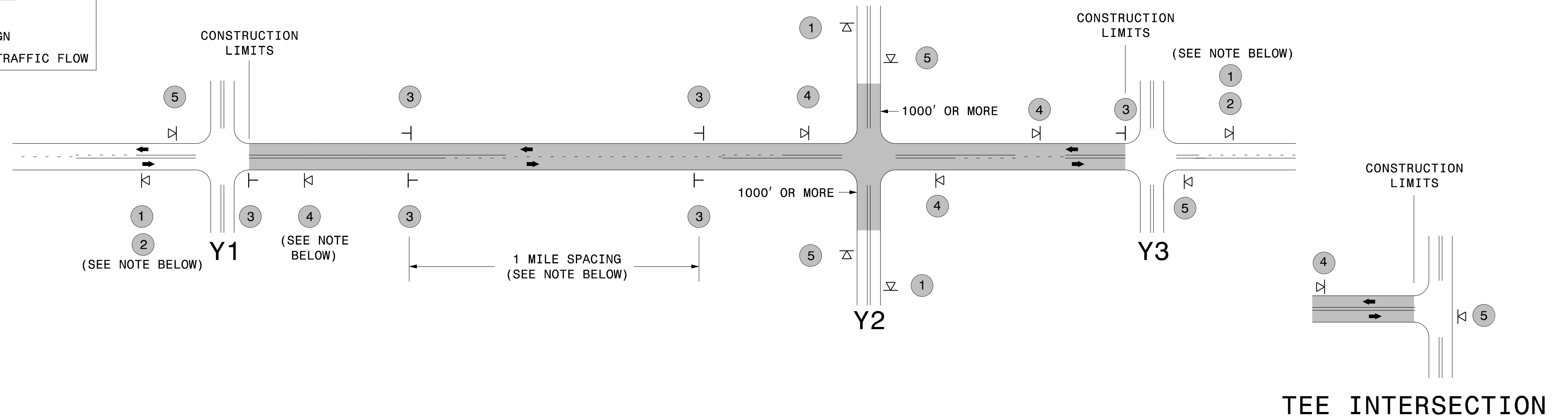

MAINLINE (-L-) SIGNING

-Y- LINE SIGNING

SIGNING NOTES AND PLACEMENT PER DIRECTION		<p>- PLACE 1000' PRIOR TO BEGINNING OF CONSTRUCTION LIMITS. ONLY USED ON -Y- LINES IF RESURFACING LIMITS EXTEND 1000' ALONG -Y- LINE.</p> <p>- SIGN #2 ONLY USED WHEN RESURFACING LIMITS ARE 2 OR MORE MILES IN LENGTH. ROUND UP TO THE NEAREST WHOLE NUMBER. DO NOT USE FRACTIONAL OR DECIMAL NUMBERS.</p>	<p>STATIONARY SIGNING NOT REQUIRED FOR THE FOLLOWING -Y- LINE CONDITIONS:</p> <ol style="list-style-type: none"> 1) LESS THAN 1000' OF RESURFACING ALONG -Y- LINE 2) SUBDIVISION ROADS 3) DEAD END ROADS <p>WHEN PAVING/CONSTRUCTION ACTIVITIES PROCEED ACROSS AN UNSIGNED -Y- LINE, PORTABLE ADVANCE WARNING SIGNS SHALL BE USED ALONG THE -Y- LINE AS SHOWN BELOW. REMOVE UPON COMPLETION OF WORK.</p> <div style="display: flex; justify-content: space-around; align-items: center;"> <div style="text-align: center;"> <p>PLACED 500' IN ADVANCE OF FLAGGER.</p> </div> <div style="text-align: center;"> <p>PLACED 250' IN ADVANCE OF FLAGGER.</p> </div> </div>
		<p>- ALTERNATE THE FOLLOWING TWO SIGNS:</p> <p>- STARTING WITH "LOOSE GRAVEL" (W8-7) FOLLOWED BY "UNMARKED PAVEMENT".</p> <p>- PLACE INITIALLY AT THE CONSTRUCTION LIMITS AND SPACED 1 MILE APART THEREAFTER.</p> <p>- AT TEE INTERSECTIONS INSTALL INITIALLY 0.5 MILE FROM INTERSECTION AND SPACE 1 MILE APART THEREAFTER.</p>	
		<p>- THESE ARE FOR -Y- LINES THAT ARE "THROUGH" ROADWAYS. DEAD END AND SUBDIVISION ROADS ARE NOT "THROUGH" ROADWAYS.</p> <p>- INSTALL 500' +/- FROM EACH -Y- LINE APPROACH AS SHOWN ABOVE.</p> <p>- FOR MULTIPLE -Y- LINES THAT ARE SEPARATED BY 0.25 MILES OR LESS, TREAT AS A SINGLE UNIT AND INSTALL WITHIN 500' OF EACH APPROACH.</p> <p>- A MAXIMUM OF 2 SIGN SETS PER MILE. DO NOT INSTALL WHEN -Y- LINES ARE WITHIN 0.5 MILES FROM "END ROAD WORK" SIGN.</p>	
		<p>PLACE 500' FOLLOWING THE END OF CONSTRUCTION LIMITS OR AS SHOWN WHEN WORK ENDS AT A 3-WAY TEE INTERSECTION.</p>	
	<p>THE ABOVE SIGNS ARE ALL THAT ARE REQUIRED FOR A CONTRACTOR TO BEGIN A RESURFACING CONTRACT. ANY ADDITIONAL SIGNS REQUESTED BY NCDOT DIVISIONS SHALL BE INSTALLED WITHIN 7 BUSINESS DAYS OF THE START OF CONTRACT WORK.</p>		
<p>MAPS LESS THAN 2 MILES</p>	<p>FOR AST RESURFACING MAPS WITH CONSTRUCTION LIMITS LESS THAN 2 MILES IN LENGTH, USE A STATIONARY "LOOSE GRAVEL" SIGN AT THE BEGINNING CONSTRUCTION LIMIT FOLLOWED BY AN "UNMARKED PAVEMENT" SIGN MIDWAY THROUGH AND AN "END ROAD WORK" SIGN AT THE END CONSTRUCTION LIMIT.</p>		



ADVANCE WARNING SIGNS FOR 2-LANE ROADWAY ASPHALT SURFACE TREATMENT

SIGNING FOR RESURFACING PROJECTS

LEGEND

┆ STATIONARY SIGN

← DIRECTION OF TRAFFIC FLOW

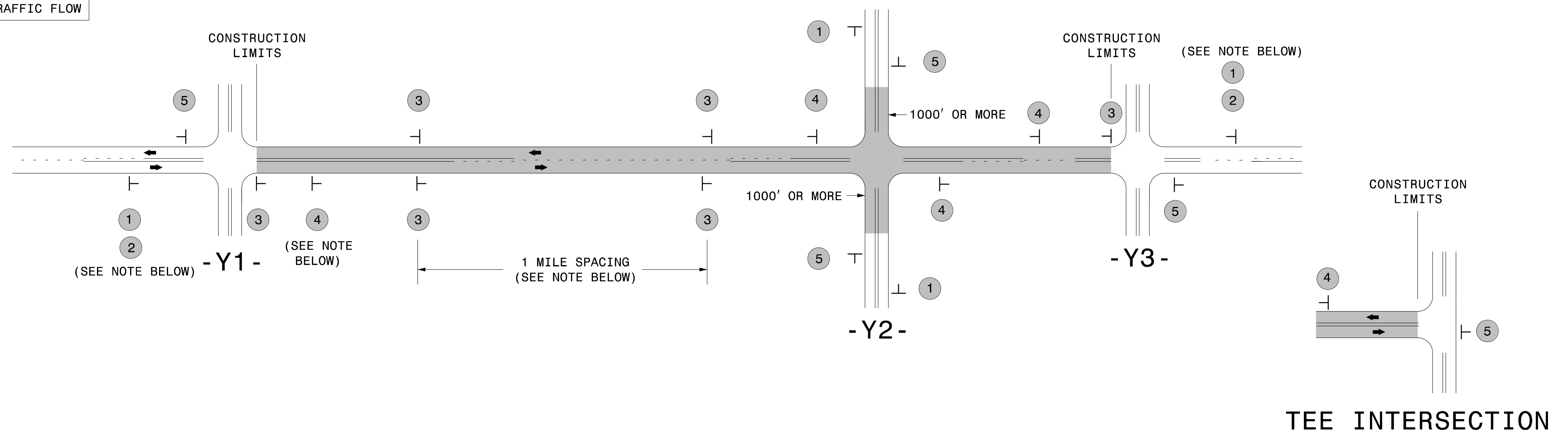

MAINLINE (-L-) SIGNING

-Y- LINE SIGNING

SIGNING NOTES AND PLACEMENT PER DIRECTION	1	 W20-1 48" X 48"	PLACE 1000' PRIOR TO BEGINNING OF CONSTRUCTION LIMITS. ONLY USED ON -Y- LINES IF RESURFACING LIMITS EXTEND 1000' ALONG -Y- LINE.	NO REQUIRED STATIONARY SIGNING FOR THE FOLLOWING -Y- LINE CONDITIONS: 1) LESS THAN 1000' OF RESURFACING ALONG -Y- LINE 2) SUBDIVISION ROADS 3) DEAD END ROADS WHEN PAVING/CONSTRUCTION ACTIVITIES PROCEED ACROSS AN UNSIGNED -Y- LINE, PORTABLE ADVANCE WARNING SIGNS SHALL BE USED ALONG THE -Y- LINE AS SHOWN BELOW. REMOVE UPON COMPLETION OF WORK. <div style="display: flex; justify-content: space-around;"> <div style="text-align: center;"> W20-1 48" X 48" PLACED 500' IN ADVANCE OF FLAGGER. </div> <div style="text-align: center;"> W20-7 A 48" X 48" PLACED 250' IN ADVANCE OF FLAGGER. </div> </div>
	2	 W7-3aP 24" X 18"	#2 SIGN ONLY USED WHEN CONSTRUCTION LIMITS ARE 2 OR MORE MILES IN LENGTH. ROUND UP TO NEXT WHOLE NUMBER. (NO FRACTIONAL OR DECIMAL NUMBERS)	
	3	 SP 13107 48" X 48"	- PLACE INITIALLY AT THE CONSTRUCTION LIMITS AND SPACE 1 MILE APART THEREAFTER. - AT TEE INTERSECTIONS INSTALL INITIALLY 1/2 MILE FROM INTERSECTION AND SPACE 1 MILE APART THEREAFTER.	
	4	 SP 13106 48" X 48"	- THESE ARE FOR -Y- LINES THAT ARE "THROUGH" ROADWAYS. - DEAD END AND SUBDIVISION ROADS ARE NOT "THROUGH" ROADWAYS. - INSTALL 500' +/- FROM EACH -Y- LINE APPROACH AS SHOWN ABOVE. - FOR MULTIPLE -Y- LINES THAT ARE SEPARATED BY 0.25 MILES OR LESS, TREAT AS A SINGLE UNIT AND INSTALL WITHIN 500' OF EACH APPROACH. - A MAXIMUM OF 2 SIGN SETS PER MILE. DO NOT INSTALL WHEN -Y- LINES ARE WITHIN 0.5 MILES FROM "END ROAD WORK" SIGN. - FOR TEE INTERSECTIONS, INSTALL WITHIN 500' +/- OF THE INTERSECTION ALONG -L- LINE.	
	5	 G20-2 A 48" X 24"	PLACE 500' FOLLOWING THE END OF CONSTRUCTION LIMITS OR AS SHOWN WHEN WORK ENDS AT A 3-WAY TEE INTERSECTION.	

THE ABOVE SIGNS ARE ALL THAT ARE REQUIRED FOR A CONTRACTOR TO BEGIN A RESURFACING CONTRACT. ANY ADDITIONAL SIGNS REQUESTED BY NCDOT DIVISIONS SHALL BE INSTALLED WITHIN 7 BUSINESS DAYS OF THE START OF CONTRACT WORK.

MAPS LESS THAN 2 MILES

FOR RESURFACING MAPS WITH CONSTRUCTION LIMITS LESS THAN 2 MILES IN LENGTH, NO STATIONARY SIGNS ARE REQUIRED. USE PORTABLE "ROAD UNDER CONSTRUCTION" OR "ROAD WORK AHEAD" SIGNS IN LIEU OF STATIONARY ADVANCE WARNINGS SIGNS.

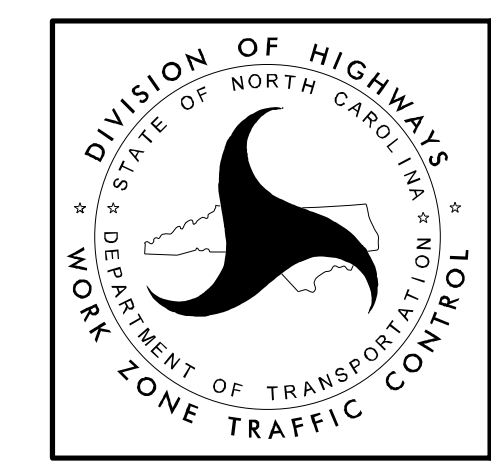

ADVANCE WARNING SIGNS FOR RURAL AND SUBURBAN 2-LANE ROADWAY RESURFACING

URBAN / SUBURBAN WORKZONES

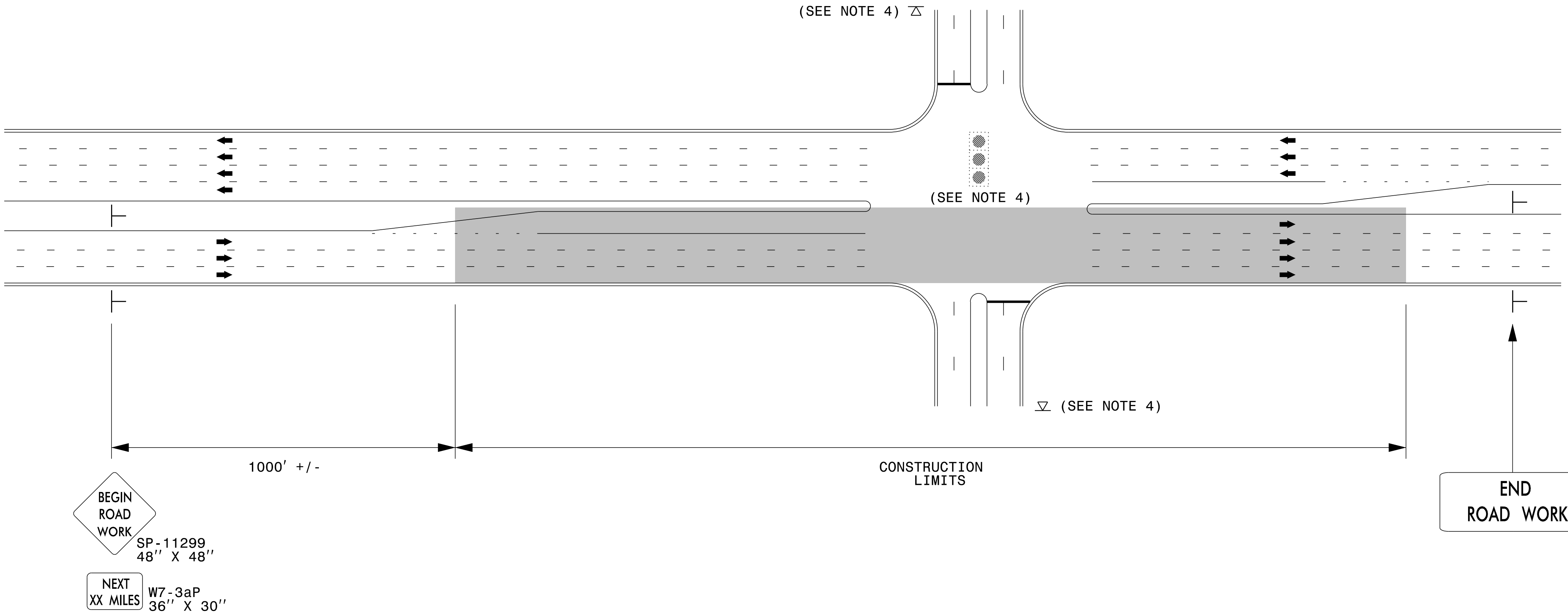

NOTES:

- 1) 48" x 48" SIZED SIGNS (SP- 11299) MAY BE REDUCED TO 36" X 36" ON ROADWAYS WITH SPEED LIMITS OF 40 MPH OR LESS.
- 2) MOUNT SIGNS THAT ARE LARGER THAN 10 SQUARE FEET IN AREA ON TWO OR MORE WOOD OR U-CHANNEL SUPPORTS. PERFORATED SQUARE TUBING SUPPORT SYSTEMS MAY SUPPORT LARGER AREAS ON A SINGLE SUPPORT. FOLLOW MANUFACTURER'S RECOMMENDATIONS. THESE SYSTEMS SHALL BE NCHRP 350 COMPLIANT AND NCDOT APPROVED.
- 3) ADVANCE WARNING SIGNS NOT REQUIRED ON NON-SIGNALIZED SIDE STREETS.
- 4) MAY USE LAW ENFORCEMENT TO CONTROL TRAFFIC AT SIGNALIZED INTERSECTIONS AS DIRECTED BY THE ENGINEER. PROVIDE PORTABLE "ROAD WORK AHEAD" (W20-1) SIGNS 500' IN ADVANCE ALONG BOTH APPROACHES FROM THE SIDE STREETS WHEN PAVING PROCEEDS THROUGH THE INTERSECTION.
- 5) LATERAL CLEARANCE AT ALL SIGN LOCATIONS SHALL BE 2' AS MEASURED FROM THE EDGE OF PAVEMENT OR THE FACE OF THE CURB. WHEN UNABLE TO OBTAIN THE LATERAL CLEARANCE WITHIN THE MEDIAN AREA USE SHOULDER MOUNTS ONLY.
- 6) SIGN MOUNT LOCATIONS SHALL NOT BLOCK SIDEWALKS OR DRIVEWAYS.
- 7) IF STATIONARY GENERAL WARNING SIGNS ARE USED, THEY WILL BE PAID FOR PER SECTION 104 OF THE NCDOT STANDARD SPECIFICATIONS AS EXTRA WORK.
- 8) IF MILLED AREAS ARE NOT PAVED BACK BY THE END OF THE WORK DAY, PORTABLE SIGNS SHALL BE USED TO WARN DRIVERS OF THE PRESENT CONDITIONS. THESE ARE TO INCLUDE, BUT NOT LIMITED TO "ROUGH ROAD" W8-8, "UNEVEN LANES" W8-11, "GROOVED PAVEMENT" W8-15 w/MOTORCYCLE PLAQUE MOUNTED BELOW. THESE ARE TO BE DOUBLE INDICATED ON MULTI-LANE ROADWAYS WITH SPEED LIMITS 45 MPH AND GREATER WHERE LATERAL CLEARANCE CAN BE OBTAINED WITHIN THE MEDIAN AREAS. THESE PORTABLE SIGNS ARE INCIDENTAL TO THE OTHER ITEMS OF WORK INCLUDED IN THE TEMPORARY TRAFFIC CONTROL (LUMP SUM) PAY ITEM.

LEGEND

┆ STATIONARY SIGN

➔ DIRECTION OF TRAFFIC FLOW

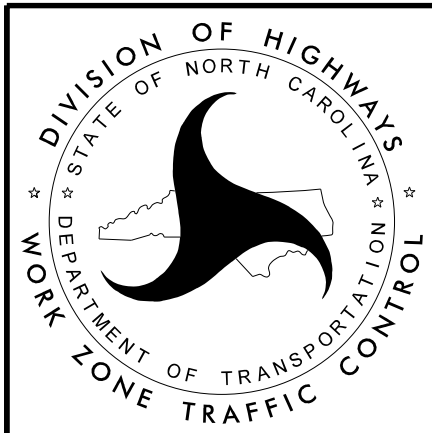

**RESURFACING ADVANCE
WARNING SIGNS FOR
URBAN / SUBURBAN
FACILITIES**

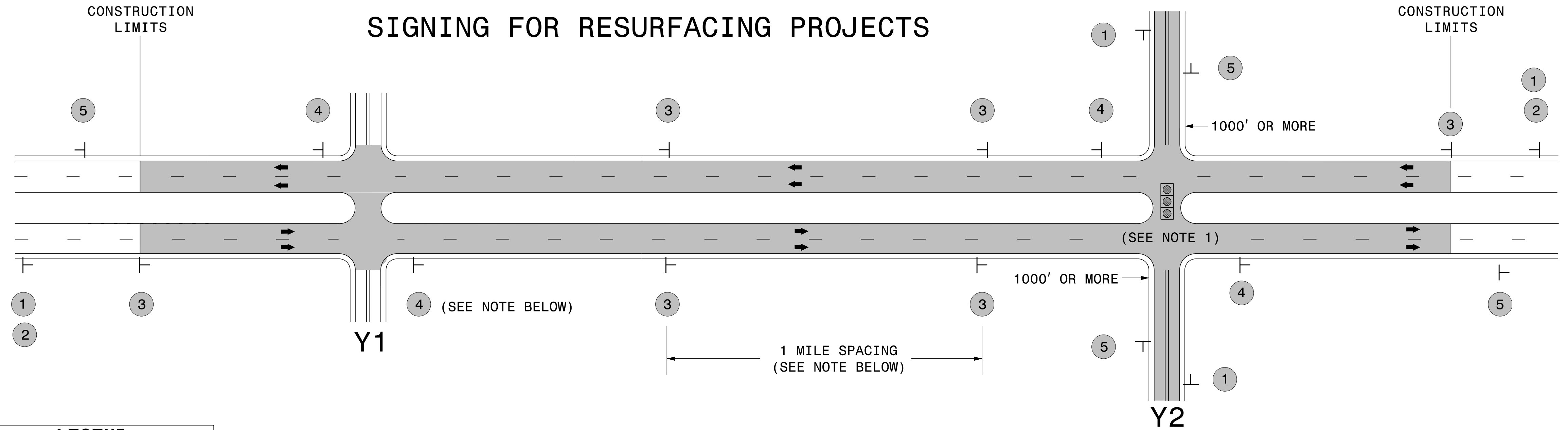

LEGEND
 ┆ STATIONARY SIGN
 ← DIRECTION OF TRAFFIC FLOW

MAINLINE (-L-) SIGNING

-Y- LINE SIGNING

SIGNING NOTES AND PLACEMENT PER DIRECTION	1	 W20-1 48" X 48"	PLACE 1000' PRIOR TO BEGINNING OF CONSTRUCTION LIMITS. ONLY USED ON -Y- LINES IF RESURFACING LIMITS EXTEND 1000' ALONG -Y- LINE.	<p>NO REQUIRED STATIONARY SIGNING FOR THE FOLLOWING -Y- LINE CONDITIONS:</p> <ol style="list-style-type: none"> 1) LESS THAN 1000' OF RESURFACING ALONG -Y- LINE 2) SUBDIVISION ROADS 3) DEAD END ROADS <p>WHEN PAVING/CONSTRUCTION ACTIVITIES PROCEED ACROSS AN UNSIGNED -Y- LINE, ADVANCE WARNING PORTABLE SIGNS SHALL BE USED ALONG THE -Y- LINE AS SHOWN BELOW. REMOVE UPON COMPLETION OF WORK.</p> <div style="display: flex; justify-content: space-around; align-items: center;"> <div style="text-align: center;"> W20-1 48" X 48" </div> <div style="text-align: center;"> W20-7 A 48" X 48" </div> </div> <p>PLACED 500' IN ADVANCE OF FLAGGER. PLACED 250' IN ADVANCE OF FLAGGER.</p> <p>NOTES:</p> <ol style="list-style-type: none"> 1) MAY USE LAW ENFORCEMENT TO CONTROL TRAFFIC AT SIGNALIZED INTERSECTIONS AS DIRECTED BY THE ENGINEER. PROVIDE PORTABLE "ROAD WORK AHEAD" (W20-1) SIGNS 500' IN ADVANCE ALONG BOTH APPROACHES FROM THE SIDE STREETS WHEN PAVING PROCEEDS THROUGH THE INTERSECTION.
	2	 W7-3aP 24" X 18"	#2 SIGN ONLY USED WHEN RESURFACING LIMITS ARE 2 OR MORE MILES IN LENGTH. ROUND UP TO NEXT WHOLE NUMBER. (NO FRACTIONAL OR DECIMAL NUMBERS)	
	3	 SP 13107 48" X 48"	PLACE INITIALLY AT THE CONSTRUCTION LIMITS AND SPACED 1 MILE APART THEREAFTER. IF NO -Y- LINES EXIST, PLACE 2ND SET 1/2 MILE FROM THE CONSTRUCTION LIMITS AND THEN SPACE 1 MILE THEREAFTER.	
	4	 SP 13106 48" X 48"	THESE ARE FOR -Y- LINES THAT ARE "THROUGH" ROADWAYS. DEAD END AND SUBDIVISION ROADS ARE NOT "THROUGH" ROADWAYS. INSTALL 500' +/- FROM EACH -Y- LINE APPROACH AS SHOWN ABOVE. FOR MULTIPLE -Y- LINES THAT ARE SEPARATED BY 0.25 MILES OR LESS, TREAT AS A SINGLE UNIT AND INSTALL WITHIN 500' OF EACH APPROACH. A MAXIMUM OF 2 SIGN SETS PER MILE. DO NOT INSTALL WHEN -Y- LINES ARE WITHIN 0.5 MILES FROM "END ROAD WORK" SIGN.	
5	 G20-2 A 48" X 24"	PLACE 500' FOLLOWING THE END OF CONSTRUCTION LIMITS.		

3/23/2015
 C:\Users\rmgarrrett\Downloads\Resurfacing_AdvWarn_Ltr-Su_Shldr.dgn
 User:rmgarrrett

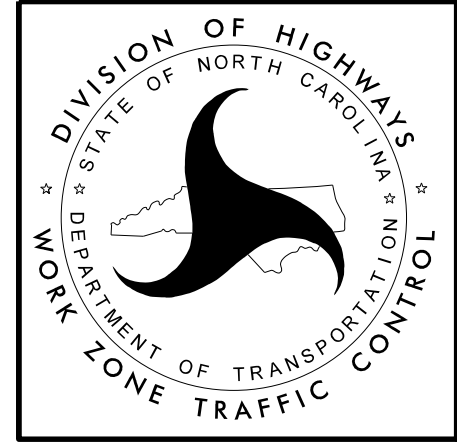

**RESURFACING
 ADVANCE WARNING SIGNS
 FOR RURAL AND SUBURBAN
 MULTI-LANE ROADWAYS
 W/ SHOULDER SECTIONS**

High Speed Detection (≥40 mph)

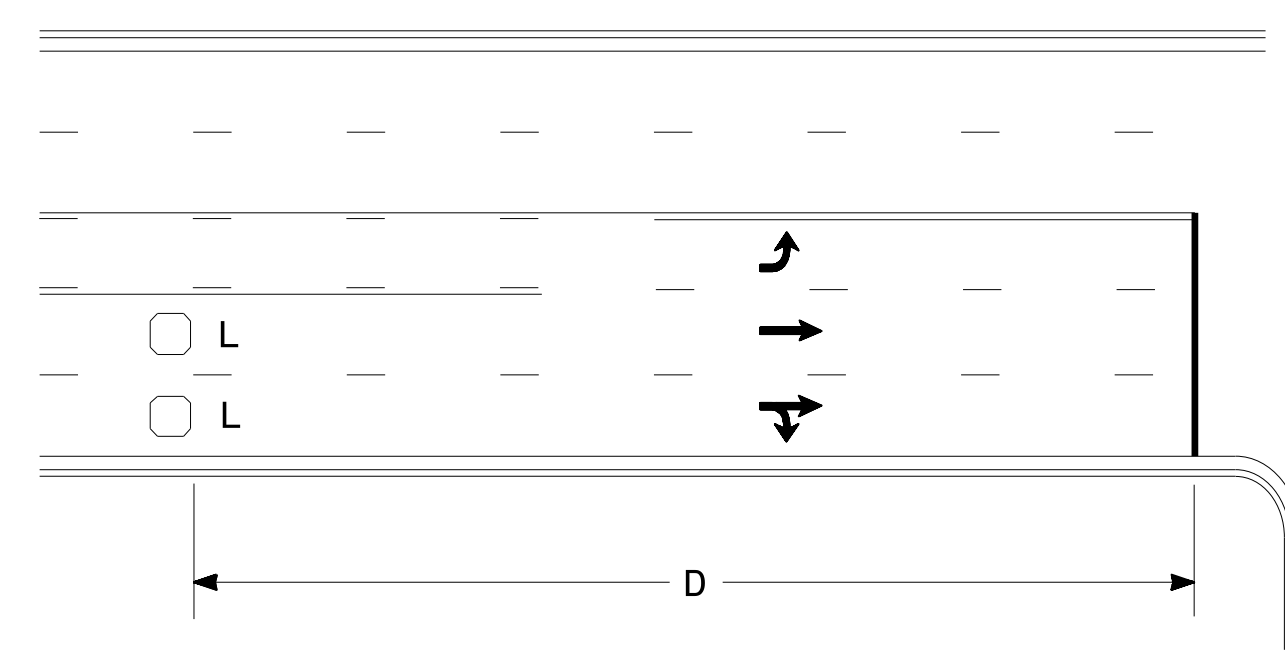

Speed Limit mph	D ft
40	250
45	300
50	355
55	420

L = 6ft X 6ft
Wired in series for TS1
Controllers
Wired separately for TS2,
170, and 2070L Controllers

Volume Density Operation

OR

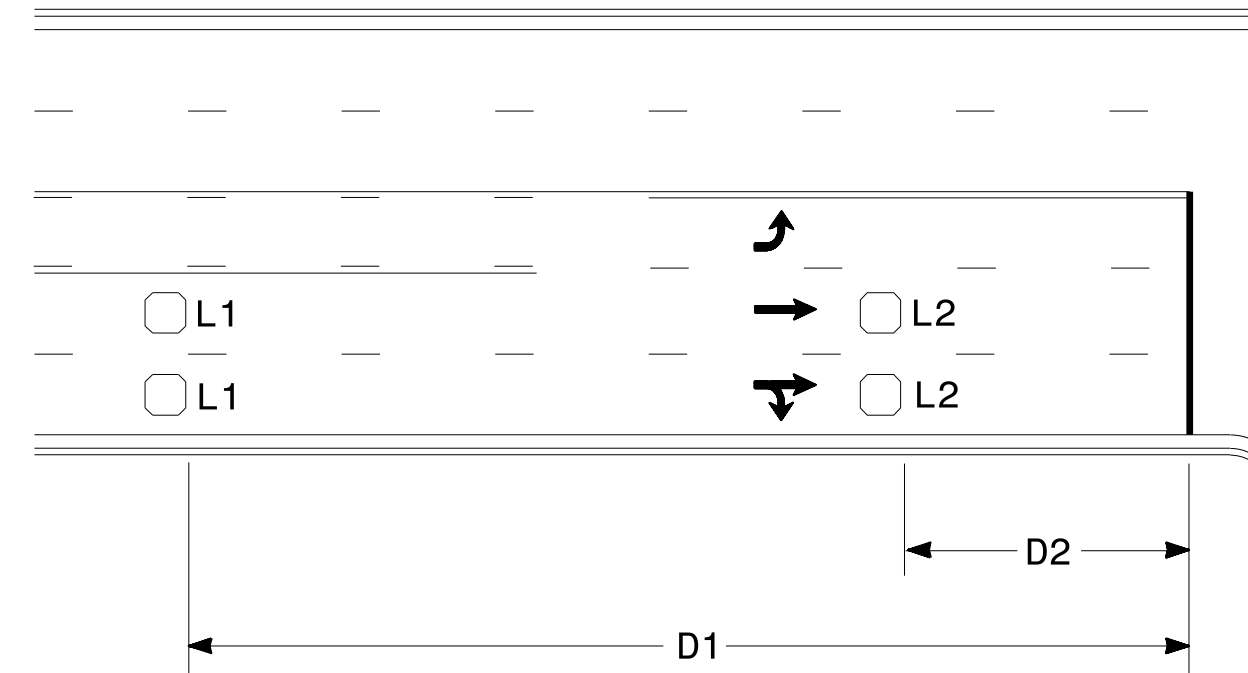

Speed Limit mph	D1 ft	D2 ft
40	250	80
45	300	90
50	355	100
55	420	110

L1 = 6ft X 6ft
Wired in series
L2 = 6ft X 6ft
Wired in series

"Stretch" Operation

Low Speed Detection (≤35 mph)

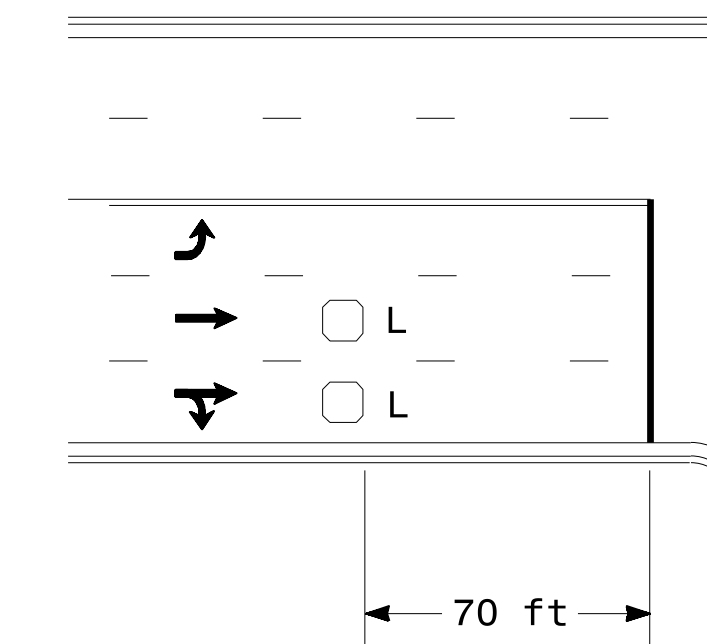

L = 6ft X 6ft
Wired in series

OR

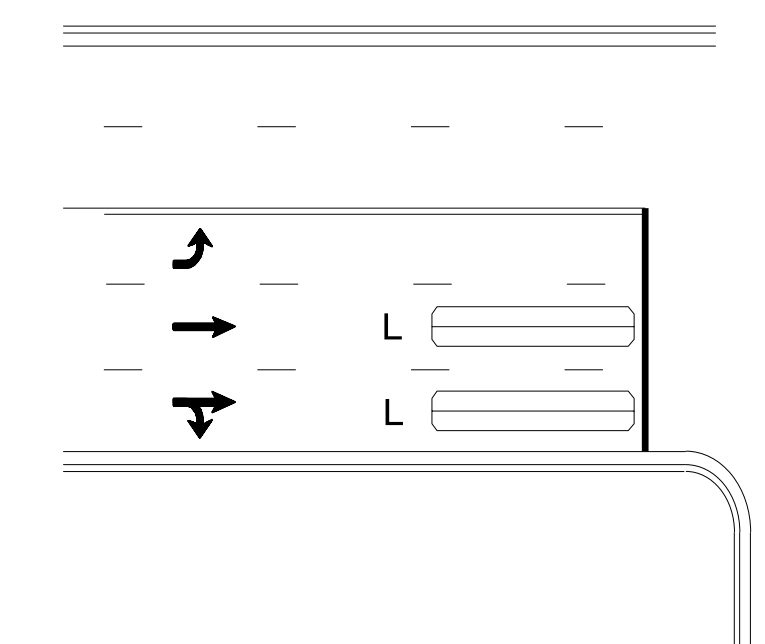

L = 6ft X 40ft
Quadrupole loop, wired separately

Left Turn Lane Detection

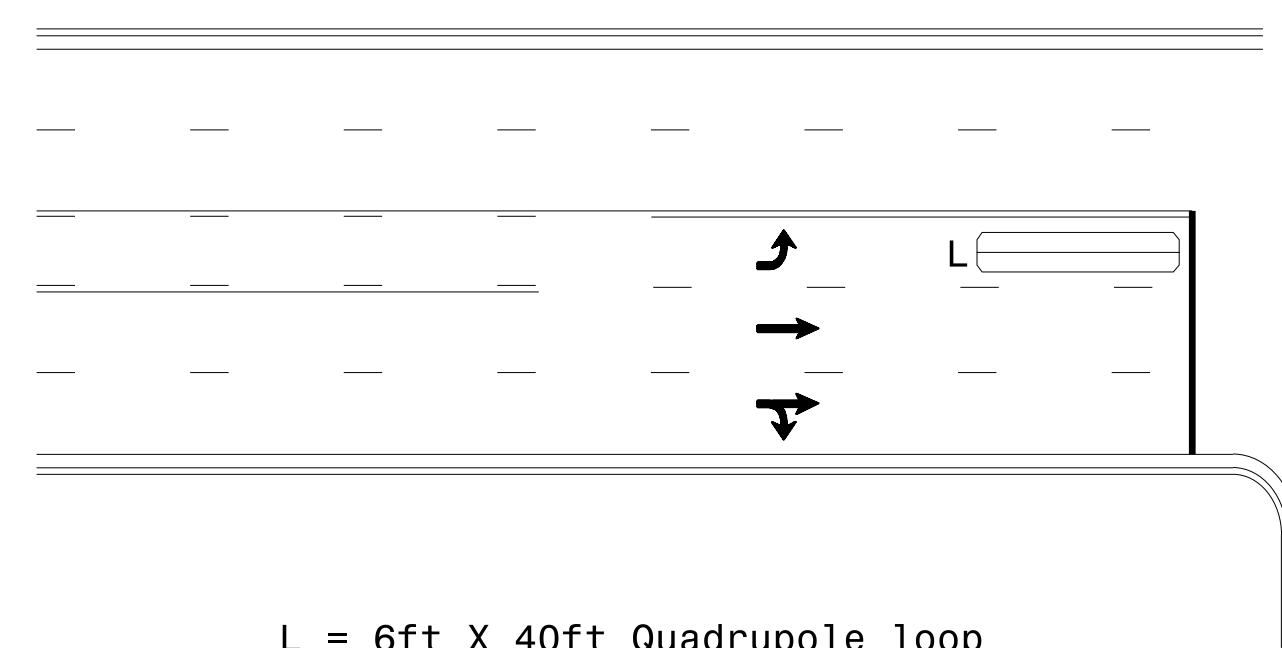

L = 6ft X 40ft Quadrupole loop

Presence Loop Detection

OR

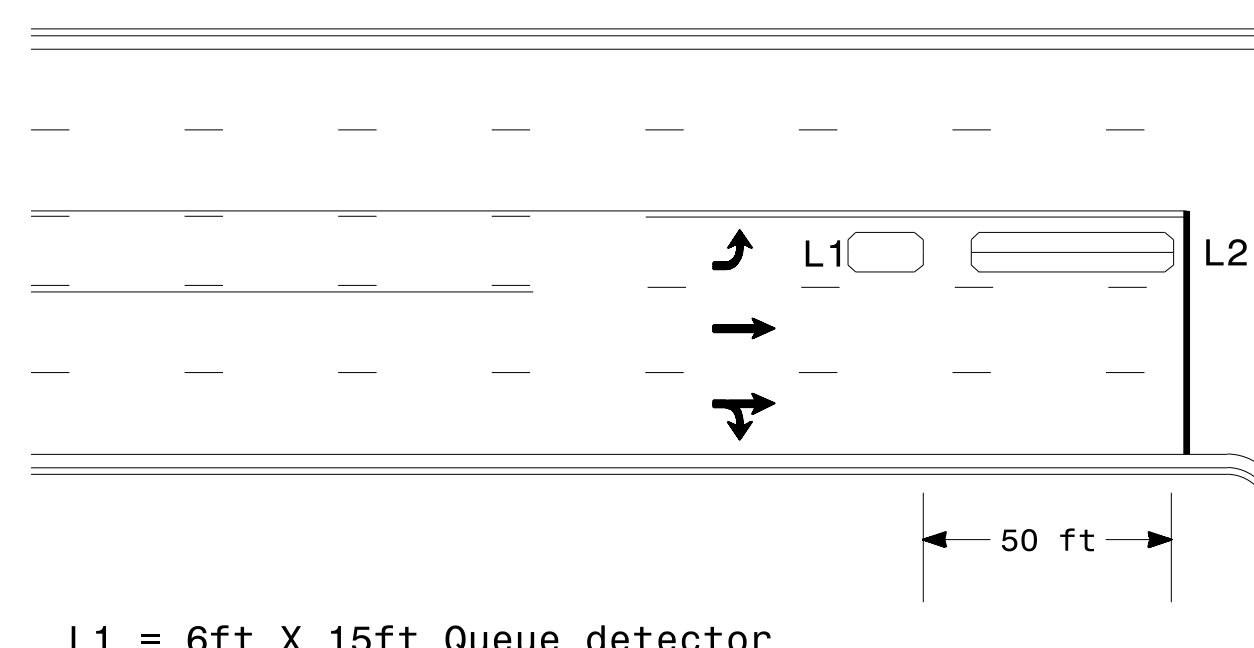

L1 = 6ft X 15ft Queue detector
L2 = 6ft X 40ft Quadrupole loop

Queue Loop Detection

Right Turn Lane Detection

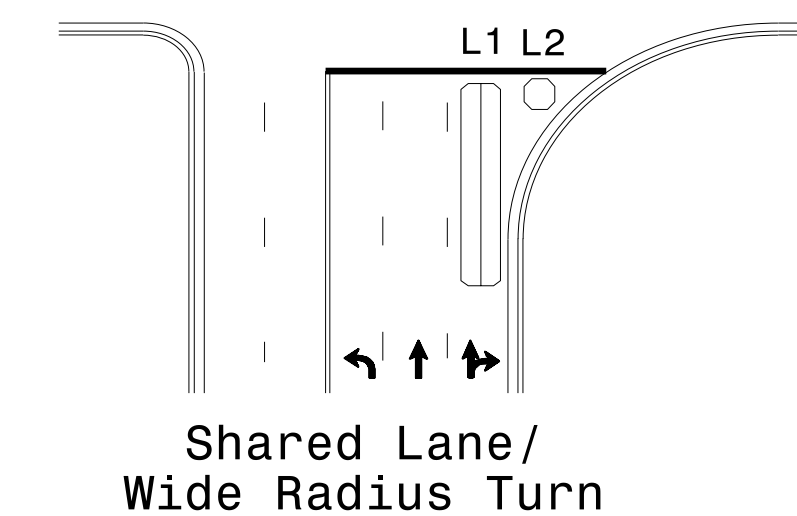

Shared Lane/
Wide Radius Turn

L1 = 6ft X 40ft Quadrupole loop
L2 = 6ft X 6ft [Minimum] Presence loop
Wired separately

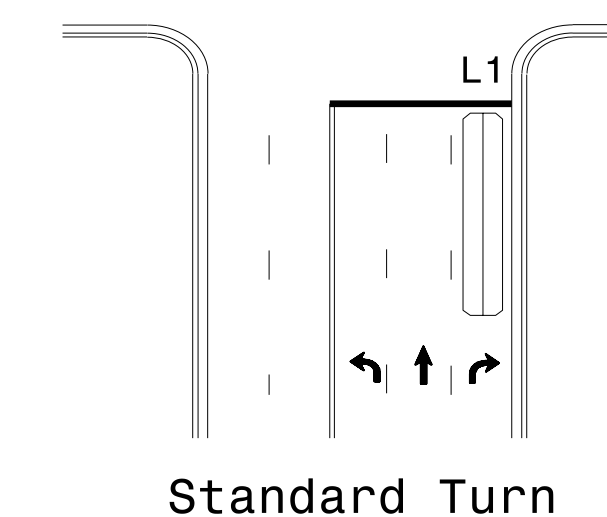

Standard Turn

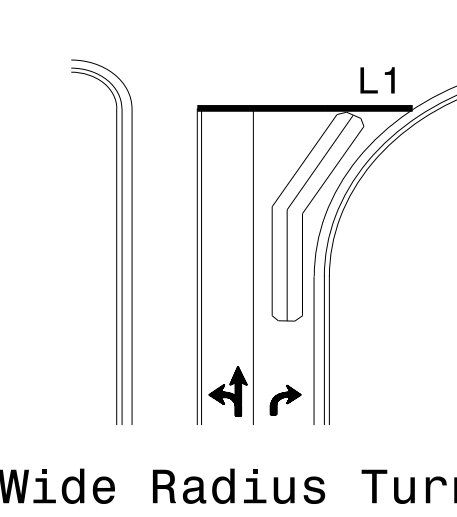

Wide Radius Turn

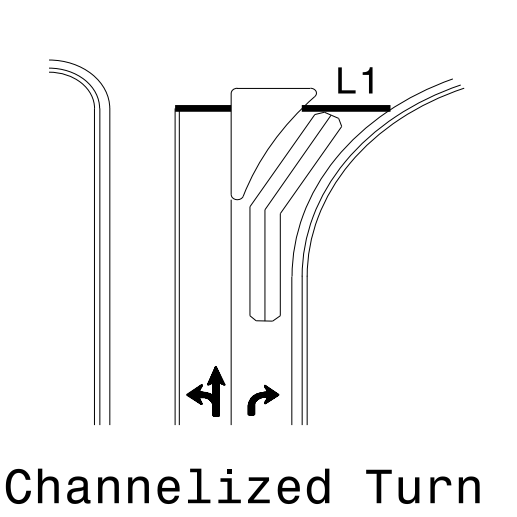

Channelized Turn

Side Street Detection

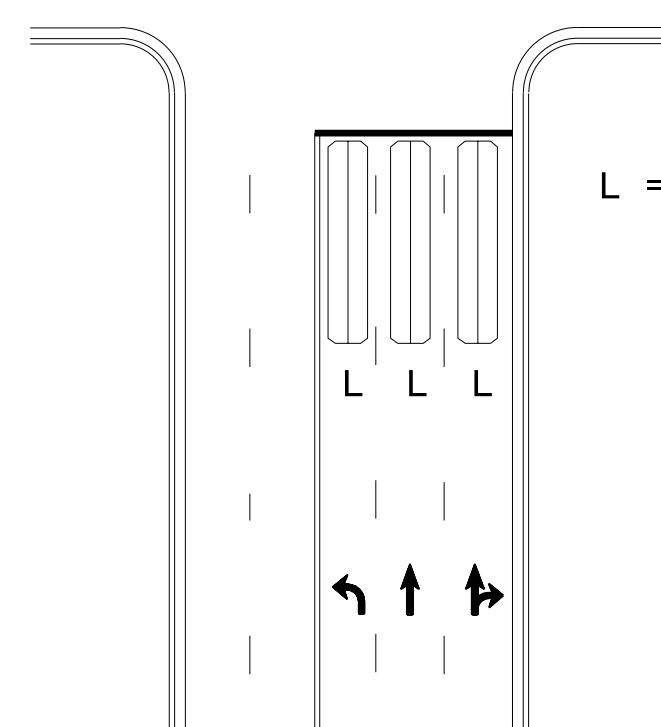

L = 6ft X 40ft
Quadrupole loop
Wired to separate
detectors/channels

Presence Loop Placement at Stop Lines

Locate loop slightly
behind leading
edge of stop line

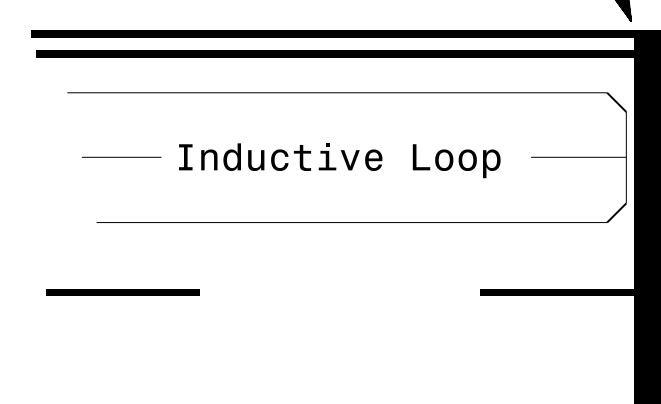

Note:

- Loop may be located in advance of stop line under any of the following conditions:
- 1) stop line is greater than 15' from edge of intersecting roadway
 - 2) loop detects a permissive or protected/permissive left turn
 - 3) for an exclusive right turn lane

Recommended Number of Turns

Single 6' X 6' loop
(when wired separately):

Length of Lead-in ft	Number of Turns
< 250	3
250-375	4
375-525	5
> 525	6

Quadrupole loops: Use 2-4-2 turns

6' X 15' Loops:
Lead-in < 150', use 2 turns
Lead-in > 150', use 3 turns

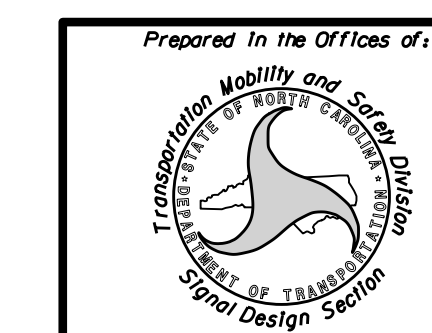

Typical Signal Loop Locations

PLAN DATE: January 2015 REVIEWED BY: JPG

PREPARED BY: PLA REVIEWED BY:

750 N. Greenfield Pkwy, Garner, NC 27529

SCALE

N/A

REVISIONS INIT. DATE

DocuSigned by: P. Alexander 1/30/2015 10:44:44 AM

SIG. INVENTORY NO. DATE