

STATE	PROJECT NO.	SHEET NO.	TOTAL SHEETS
N.C.	2019CPT.10.01.10901.I, etc.	36	
F.A. PROJECT NO.			

PAVEMENT SCHEDULE

(C1)	PROP. APPROX. 2.0" ASPHALT CONC. SURFACE COURSE, TYPE S9.5C, AT AN AVERAGE RATE OF 224 LBS. PER SQ. YD.
(C2)	PROP. APPROX. 1.5" ASPHALT CONC. SURFACE COURSE, TYPE S9.5C, AT AN AVERAGE RATE OF 168 LBS. PER SQ. YD.
(C3)	PROP. APPROX. 2.0" ASPHALT CONC. SURFACE COURSE, TYPE S9.5B, AT AN AVERAGE RATE OF 220 LBS. PER SQ. YD.
(C4)	PROP. APPROX. 1.0" ASPHALT CONC. SURFACE COURSE, TYPE S9.5B, AT AN AVERAGE RATE OF 110 LBS. PER SQ. YD.
(C5)	PROP. ASPHALT SURFACE TREATMENT, DOUBLE SEAL, (SEE S. P. FOR AGGREGATE TYPE.)
(D1)	PROPOSED 2.5" ASPHALT CONC. INTERMEDIATE COURSE, TYPE I19.0C, AT AN AVERAGE RATE OF 285 LBS. PER SQ. YD.
(D2)	AST MAT COAT # 67
(D3)	AST MAT COAT # 78M
(E1)	PROP. APPROX. 5" ASPHALT BASE COURSE, TYPE B25.0C, AT AN AVERAGE RATE OF 570 LBS PER SQYD.
(T1)	SHOULDER RECONSTRUCTION
(V1)	PROFILE MILLING EXISTING ASPHALT, 0 - 2.0"
(V2)	PROFILE MILLING EXISTING ASPHALT, 0 - 1.5"
(V3)	MILLING 1' OF EXISTING PAVEMENT, 5" IN DEPTH. (SEE S.P. FOR "TRENCHING FOR BASE COURSE BY MILLING.")
(W)	EXISTING CONCRETE PAVEMENT
(U)	EXISTING PAVEMENT
(Z)	FULL DEPTH RECLAMATION

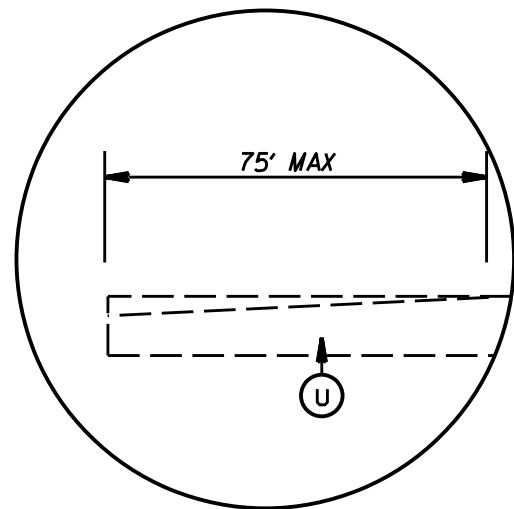

DETAIL FOR INCIDENTAL MILLING (0" TO 2.0")

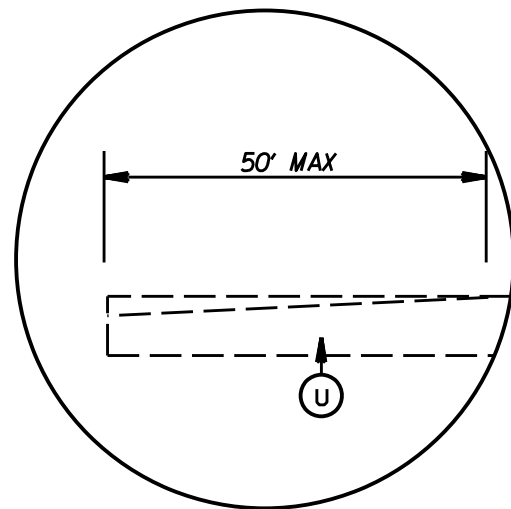

DETAIL FOR INCIDENTAL MILLING (0" TO 1.5")

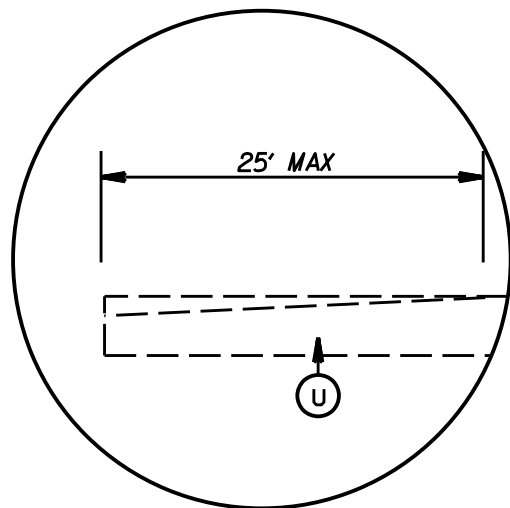

DETAIL FOR INCIDENTAL MILLING (0" TO 1.0")

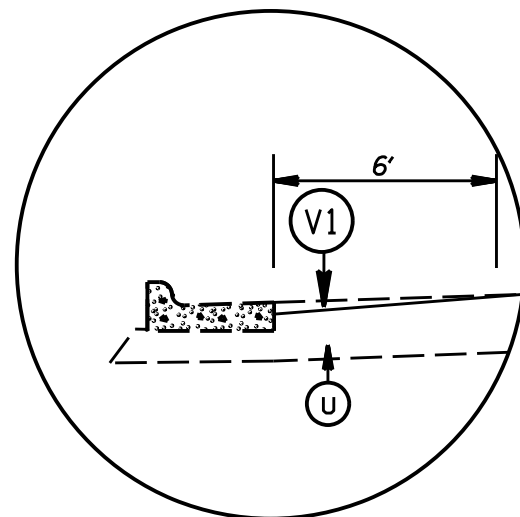

DETAIL FOR PROFILE MILLING

PATCHING DETAIL

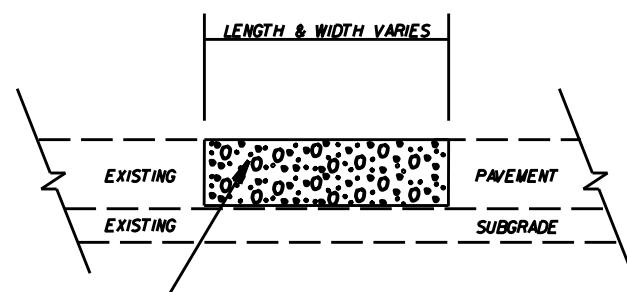

RATE IS VARIABLE AND SHALL BE AS DIRECTED BY THE ENGINEER. ASPHALT TYPE I190C SHALL BE PLACED.

2018-2019
UNION COUNTY RESURFACING

SCALE	-NA-		REVISIONS
DATE	01/18		
DWG. BY	AMO		
DESIGN BY	AMO		
APPROVED	CLA		