

**This electronic collection of documents is provided  
for the convenience of the user  
and is Not a Certified Document –**

**The documents contained herein were originally issued  
and sealed by the individuals whose names and license  
numbers appear on each page, on the dates appearing  
with their signature on that page.**

**This file or an individual page  
shall not be considered a certified document.**

TIP NO. R-2501C	SHEET NO. PMP-1
APPROVED: <u>Andrew D. Klinksiek</u> <small>ES078F845065418</small> DATE: 2/5/2018	
	
DOCUMENT NOT CONSIDERED FINAL UNLESS ALL SIGNATURES COMPLETED	

**STATE OF NORTH CAROLINA  
DEPARTMENT OF TRANSPORTATION**

**PAVEMENT MARKING PLAN  
RICHMOND COUNTY**

**T.I.P.: R-2501C**

**CONTRACT: C203615**

**INDEX**

SHEET NO.	DESCRIPTION
PMP-1	PAVEMENT MARKING PLAN COVER SHEET
PMP-1A	PAVEMENT MARKING SCHEDULE AND LEGEND
PMP-2 THRU PMP-11	PAVEMENT MARKING DETAIL

**GENERAL NOTES**

THE FOLLOWING GENERAL NOTES APPLY AT ALL TIMES FOR THE DURATION OF THE CONSTRUCTION PROJECT, EXCEPT WHEN OTHERWISE NOTED IN THE PLAN, OR DIRECTED BY THE ENGINEER.

A) INSTALL PAVEMENT MARKINGS AND PAVEMENT MARKERS ON THE FINAL SURFACE AS FOLLOWS:

ROAD NAME	MARKING	MARKER
-L- US 1	THERMOPLASTIC W/ HIGHLY REFLECTIVE MEDIA	SNOWPLOWABLE
-Y- LINES	THERMOPLASTIC W/ HIGHLY REFLECTIVE MEDIA	MATCH EXISTING

- B) TIE PROPOSED PAVEMENT MARKING LINES TO EXISTING PAVEMENT MARKING LINES.
- C) REMOVE/REPLACE ANY CONFLICTING/DAMAGED PAVEMENT MARKINGS AND MARKERS.
- D) PASSING ZONES WILL BE DETERMINED IN THE FIELD AND MUST BE APPROVED BY THE ENGINEER.
- E) STOP BAR LOCATION AT NON-SIGNALIZED INTERSECTIONS MAY BE ADJUSTED AS DIRECTED BY THE ENGINEER.
- F) UNLESS OTHERWISE SPECIFIED, HEATED-IN-PLACE THERMOPLASTIC MAY BE USED IN LIEU OF EXTRUDED THERMOPLASTIC FOR STOP BARS, SYMBOLS, CHARACTERS AND DIAGONALS. IF HEATED-IN-PLACE IS USED, IT SHALL BE PAID FOR USING THE EXTRUDED THERMOPLASTIC PAY ITEM.

**ROADWAY STANDARD DRAWING**

THE FOLLOWING ROADWAY STANDARDS AS APPEAR IN "ROADWAY STANDARD DRAWINGS" - PROJECT SERVICES UNIT - N.C. DEPARTMENT OF TRANSPORTATION - RALEIGH, N.C., DATED JANUARY 2018 ARE APPLICABLE TO THIS PROJECT AND BY REFERENCE HEREBY ARE CONSIDERED A PART OF THESE PLANS:

STD. NO.	TITLE
1205.01	PAVEMENT MARKINGS - LINE TYPES AND OFFSETS
1205.02	PAVEMENT MARKINGS - TWO-LANE AND MULTILANE ROADWAYS
1205.03	PAVEMENT MARKINGS - EXIT AND ENTRANCE RAMP
1205.04	PAVEMENT MARKINGS - INTERSECTIONS
1205.05	PAVEMENT MARKINGS - TURN LANES
1205.06	PAVEMENT MARKINGS - LANE DROPS
1205.07	PAVEMENT MARKINGS - PEDESTRIAN CROSSWALK
1205.08	PAVEMENT MARKINGS - SYMBOLS AND WORD MESSAGES
1205.09	PAVEMENT MARKINGS - PAINTED ISLANDS
1205.15	PAVEMENT MARKINGS - SUPERSTREETS
1250.01	RAISED PAVEMENT MARKERS - INSTALLATION SPACING
1251.01	RAISED PAVEMENT MARKERS - PERMANENT AND TEMPORARY
1253.01	RAISED PAVEMENT MARKERS - SNOWPLOWABLE
1261.01	GUARDRAIL AND BARRIER DELINEATORS - INSTALLATION SPACING
1261.02	GUARDRAIL AND BARRIER DELINEATORS - TYPES AND MOUNTING
1262.01	GUARDRAIL END DELINEATION

**PLAN REVIEWED BY: N.C.D.O.T. SIGNING AND DELINEATION UNIT**

<u>Ayman Alqudwah, PE, CPM</u>	SIGNING & DELINEATION STANDARDS ENGINEER
<u>Stacey Johns</u>	SIGNING & DELINEATION PROJECT DESIGN ENGINEER

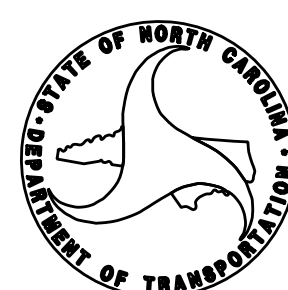

**PLAN PREPARED BY: HNTB NORTH CAROLINA, P.C.**

<u>A.D. Klinksiek, PE, PTOE</u>	PROJECT ENGINEER
<u>J.A. Phillips</u>	DESIGN TECHNICIAN



HNTB NORTH CAROLINA, P.C.  
343 E. SIX FORKS ROAD, SUITE 200  
RALEIGH, NORTH CAROLINA 27609  
NC LICENSE NO: C-1554  
(919) 546-8997

TIP NO. R - 2501C	SHEET NO. PMP - 1A
APPROVED: <i>Andrew D. Klinck</i> <small>E3078F8459E44B</small>	
DATE: 2/27/2018	
	
<b>DOCUMENT NOT CONSIDERED FINAL UNLESS ALL SIGNATURES COMPLETED</b>	

# FINAL PAVEMENT MARKING SCHEDULE

MATERIAL	SYMBOL	DESCRIPTION
<b>PAVEMENT MARKING</b>		
<u>THERMOPLASTIC (4", 90 MILS)</u>		
	TA	WHITE EDGELINE
	TB	YELLOW EDGELINE
<u>THERMOPLASTIC (4", 120 MILS)</u>		
	T8	WHITE MINI SKIPS (2'/6')
	T9	YELLOW MINI SKIPS (2'/6')
	TC	WHITE SKIP
	TD	WHITE MINISKIP (3'/9')
	TE	WHITE SOLID LANE LINE
	TF	YELLOW SKIP
	TH	YELLOW SINGLE CENTER
	TI	YELLOW DOUBLE CENTER
<u>THERMOPLASTIC (8", 90 MILS)</u>		
	TN	WHITE GORELINE
	TO	WHITE DIAGONAL
<u>THERMOPLASTIC (8", 120 MILS)</u>		
	T13	WHITE MINI SKIP (3'/9')
	TR	WHITE SOLID LANE LINE
<u>THERMOPLASTIC (12", 90 MILS)</u>		
	TU	WHITE DIAGONAL
	TV	YELLOW DIAGONAL
<u>THERMOPLASTIC (24", 120 MILS)</u>		
	T2	WHITE STOPBAR
<u>THERMOPLASTIC PAVEMENT MARKING SYMBOLS (90 MILS)</u>		
	UA	LEFT TURN ARROW
	UB	RIGHT TURN ARROW
	UC	STRAIGHT ARROW
	UE	COMBO STRAIGHT/RIGHT
	UP	MERGE ARROW
	UT	U-TURN ARROW
<u>THERMOPLASTIC PAVEMENT MARKING CHARACTER (120 MILS)</u>		
	UI	ALPHANUMERIC CHAR.
<u>PERMANENT RAISED PAVEMENT MARKERS (NOT SHOWN)</u>		
	MA	YELLOW & YELLOW
	MB	CRYSTAL & RED
<u>SNOWPLOWABLE PAVEMENT MARKERS (NOT SHOWN)</u>		
	ME	YELLOW & YELLOW
	MF	CRYSTAL & RED

**PAVEMENT MARKING SYMBOLS**

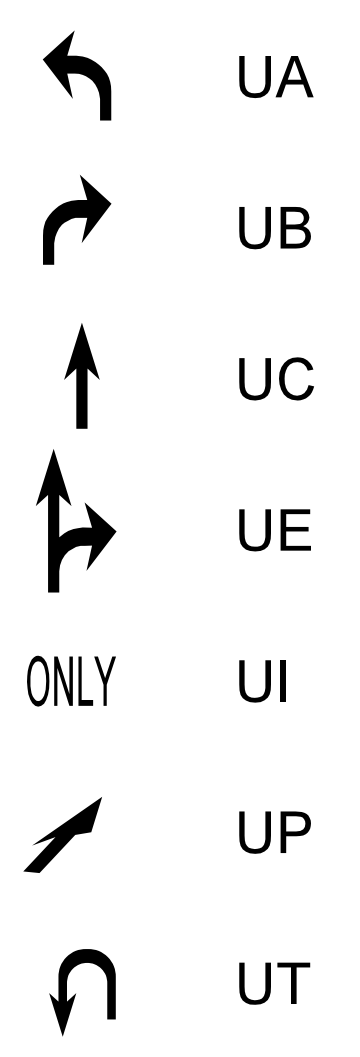

UA  
UB  
UC  
UE  
UI  
UP  
UT

## LEGEND

**GENERAL**

DIRECTION OF TRAFFIC FLOW

NORTH ARROW

PROPOSED PVMT.    EXIST. PVMT.

**PAVEMENT MARKINGS**

PAVEMENT MARKING SYMBOLS

2/27/2018  
PMP-2501C-PMP\_01-1A.dgn  
HNTB

**HNTB** HNTB NORTH CAROLINA, P.C.  
343 E. SIX FORKS ROAD, SUITE 200  
RALEIGH, NORTH CAROLINA 27609  
NC LICENSE NO: C-1554  
(919) 546-8997

**PAVEMENT MARKING SCHEDULE  
AND LEGEND**





TIP NO. R-2501C	SHEET NO. PMP-3
APPROVED: <i>Andrew D. Klinsiek</i> E3078F84595E448 2/5/2018	
DATE: 2/5/2018	
SEAL 	
DOCUMENT NOT CONSIDERED FINAL UNLESS ALL SIGNATURES COMPLETED	

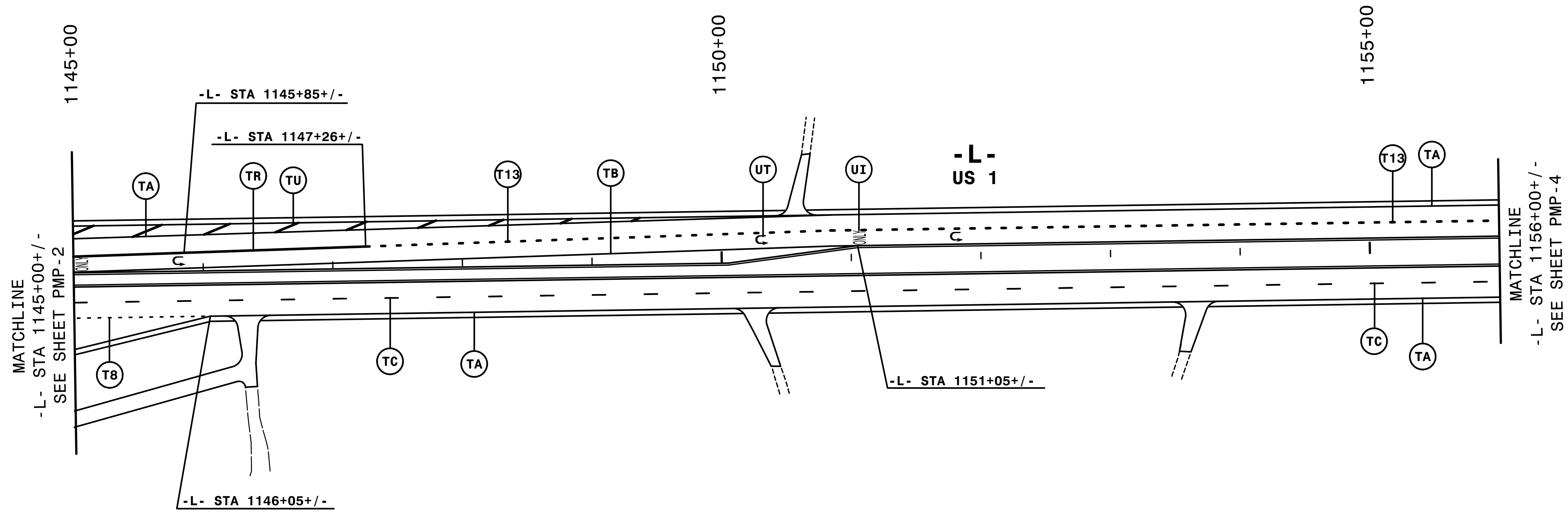

NOTE: ALL LANE WIDTHS ARE 12' UNLESS OTHERWISE SHOWN.

2/5/2018  
T:\GFF\c\pmp\R2501C\_PMP\_03.dgn  
HNTB

**HNTB**  
 HNTB NORTH CAROLINA, P.C.  
 343 E. SIX FORKS ROAD, SUITE 200  
 RALEIGH, NORTH CAROLINA 27609  
 NC LICENSE NO: C-1554  
 (919) 546-8997

**PAVEMENT MARKING DETAIL**

TIP NO. R-2501C	SHEET NO. PMP-4
APPROVED: <i>Andrew D. Klinsky</i> E3078F84595E448 2/5/2018	
DATE: 2/5/2018	
SEAL	
	
DOCUMENT NOT CONSIDERED FINAL UNLESS ALL SIGNATURES COMPLETED	

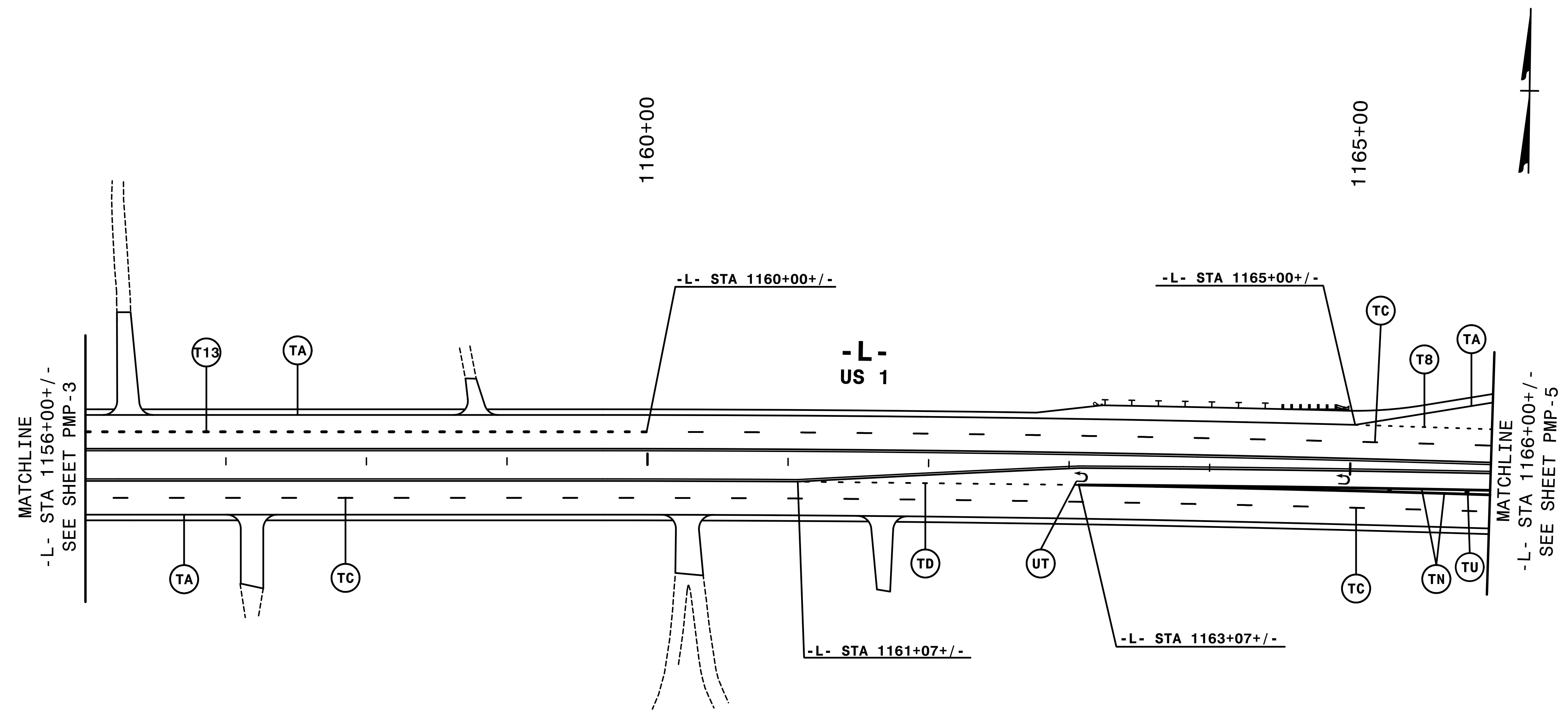

NOTE: ALL LANE WIDTHS ARE 12' UNLESS OTHERWISE SHOWN.

2/5/2018  
T:\GFF\c\pmp\R2501C\_PMP\_04.dgn  
HNTB

**HNTB**  
 HNTB NORTH CAROLINA, P.C.  
 343 E. Six Forks Road, Suite 200  
 Raleigh, North Carolina 27609  
 NC License No: C-1554  
 (919) 546-8997

**PAVEMENT MARKING DETAIL**



TIP NO. R-2501C	SHEET NO. PMP-6
APPROVED: <i>Andrew D. Klinsky</i> E3078F84595E448 DATE: 2/5/2018	
SEAL 	
DOCUMENT NOT CONSIDERED FINAL UNLESS ALL SIGNATURES COMPLETED	

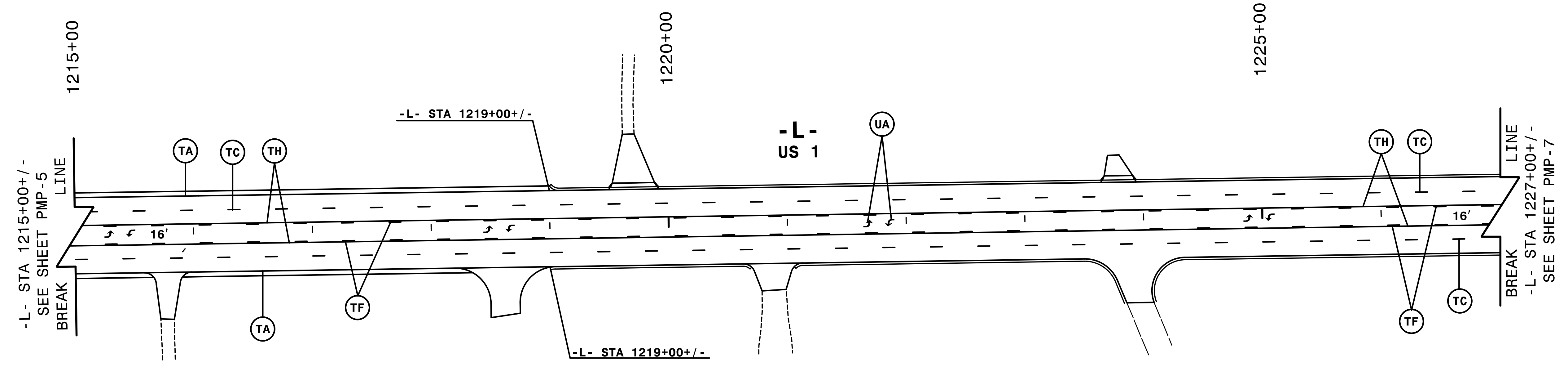

NOTE: ALL LANE WIDTHS ARE 12' UNLESS OTHERWISE SHOWN.

**HNTB**  
 HNTB NORTH CAROLINA, P.C.  
 343 E. Six Forks Road, Suite 200  
 Raleigh, North Carolina 27609  
 NC License No: C-1554  
 (919) 546-8997

# PAVEMENT MARKING DETAIL

2/5/2018  
 \\T-0711c\pmp\R2501C\_PMP\_06.dgn  
 HNTB



TIP NO. R-2501C	SHEET NO. PMP-7
APPROVED: <i>Andrew D. Klinsky</i> E3078F84595E448 2/5/2018	
DATE: 2/5/2018	
SEAL 	
DOCUMENT NOT CONSIDERED FINAL UNLESS ALL SIGNATURES COMPLETED	

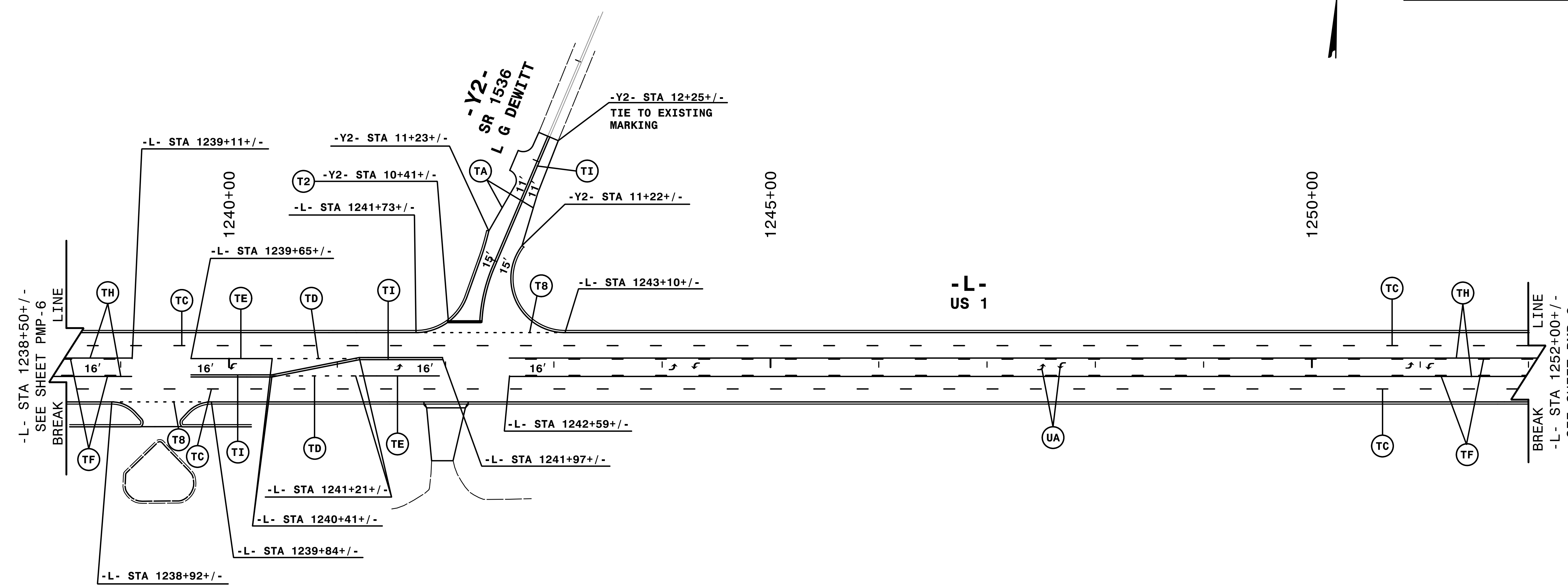

NOTE: ALL LANE WIDTHS ARE 12' UNLESS OTHERWISE SHOWN.  
ENGINEER TO APPROVE LOCATION OF ALL UNSIGNALIZED STOPBARS.

**HNTB**  
HNTB NORTH CAROLINA, P.C.  
343 E. SIX FORKS ROAD, SUITE 200  
RALEIGH, NORTH CAROLINA 27609  
NC License No: C-1554  
(919) 546-8997

**PAVEMENT MARKING DETAIL**

2/5/2018  
T:\GFF\c\pmp\R2501C\_PMP\_07.dgn  
HNTB

TIP NO. R - 2501C	SHEET NO. PMP - 8
APPROVED: <i>Andrew D. Klinsky</i> E3078F84595E448 2/5/2018	
DATE: 2/5/2018	
SEAL	
	
DOCUMENT NOT CONSIDERED FINAL UNLESS ALL SIGNATURES COMPLETED	

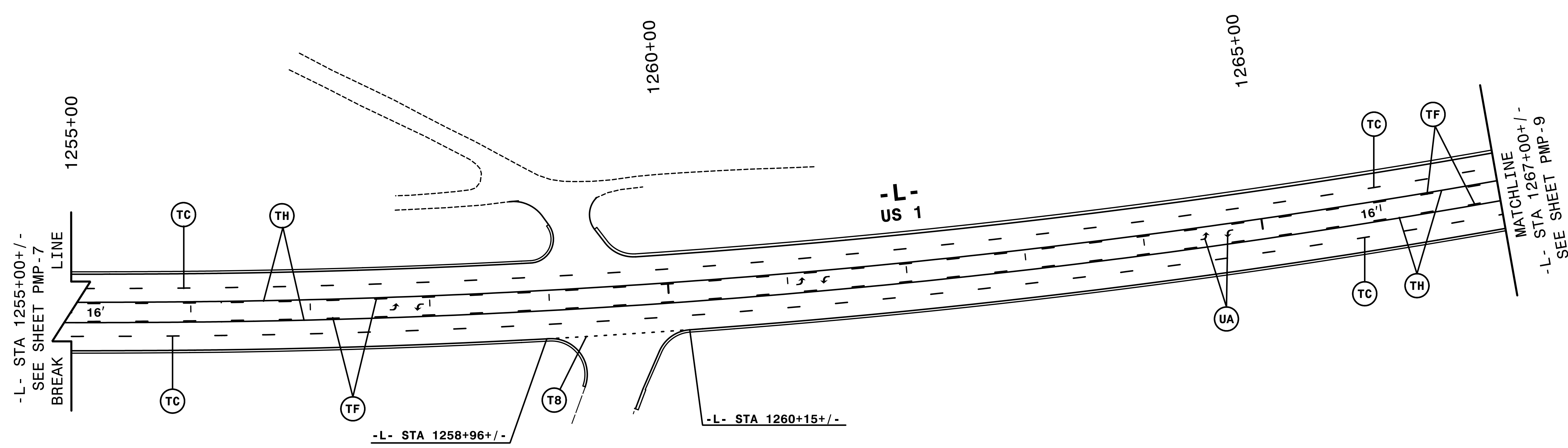

NOTE: ALL LANE WIDTHS ARE 12' UNLESS OTHERWISE SHOWN.

2/5/2018  
T:\GFF\c\pmp\R2501C\_PMP\_08.dgn  
HNTB

**HNTB**  
HNTB NORTH CAROLINA, P.C.  
343 E. Six Forks Road, Suite 200  
Raleigh, North Carolina 27609  
NC License No: C-1554  
(919) 546-8997

**PAVEMENT MARKING DETAIL**

TIP NO. R-2501C	SHEET NO. PMP-9
APPROVED: <i>Andrew D. Hinkley</i> E3078F84595E448 2/5/2018	
DATE: 2/5/2018	
SEAL 	
DOCUMENT NOT CONSIDERED FINAL UNLESS ALL SIGNATURES COMPLETED	

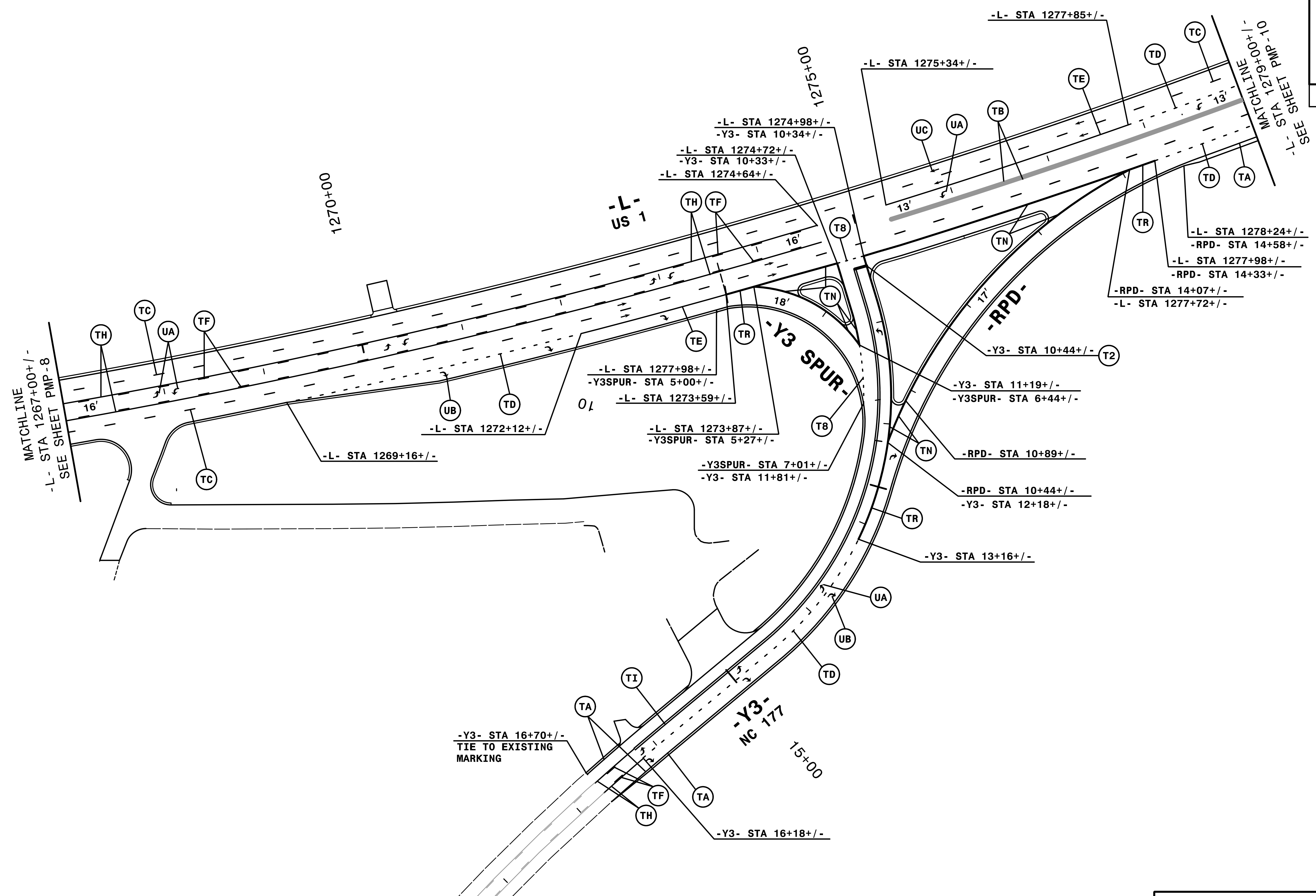

NOTE: ALL LANE WIDTHS ARE 12' UNLESS OTHERWISE SHOWN.

2/5/2018  
2:\1\T\G\FF\c\pmp\R2501C\_PMP\_09.dgn  
HNTB

**HNTB**  
HNTB NORTH CAROLINA, P.C.  
343 E. Six Forks Road, Suite 200  
Raleigh, North Carolina 27609  
NC License No: C-1554  
(919) 546-8997

**PAVEMENT MARKING DETAIL**



TIP NO. R-2501C	SHEET NO. PMP-10
APPROVED: <u>Andrew D. Klinsiek</u> <small>E3078F84595E448 2/5/2018</small>	
DATE: _____	
SEAL 	
DOCUMENT NOT CONSIDERED FINAL UNLESS ALL SIGNATURES COMPLETED	

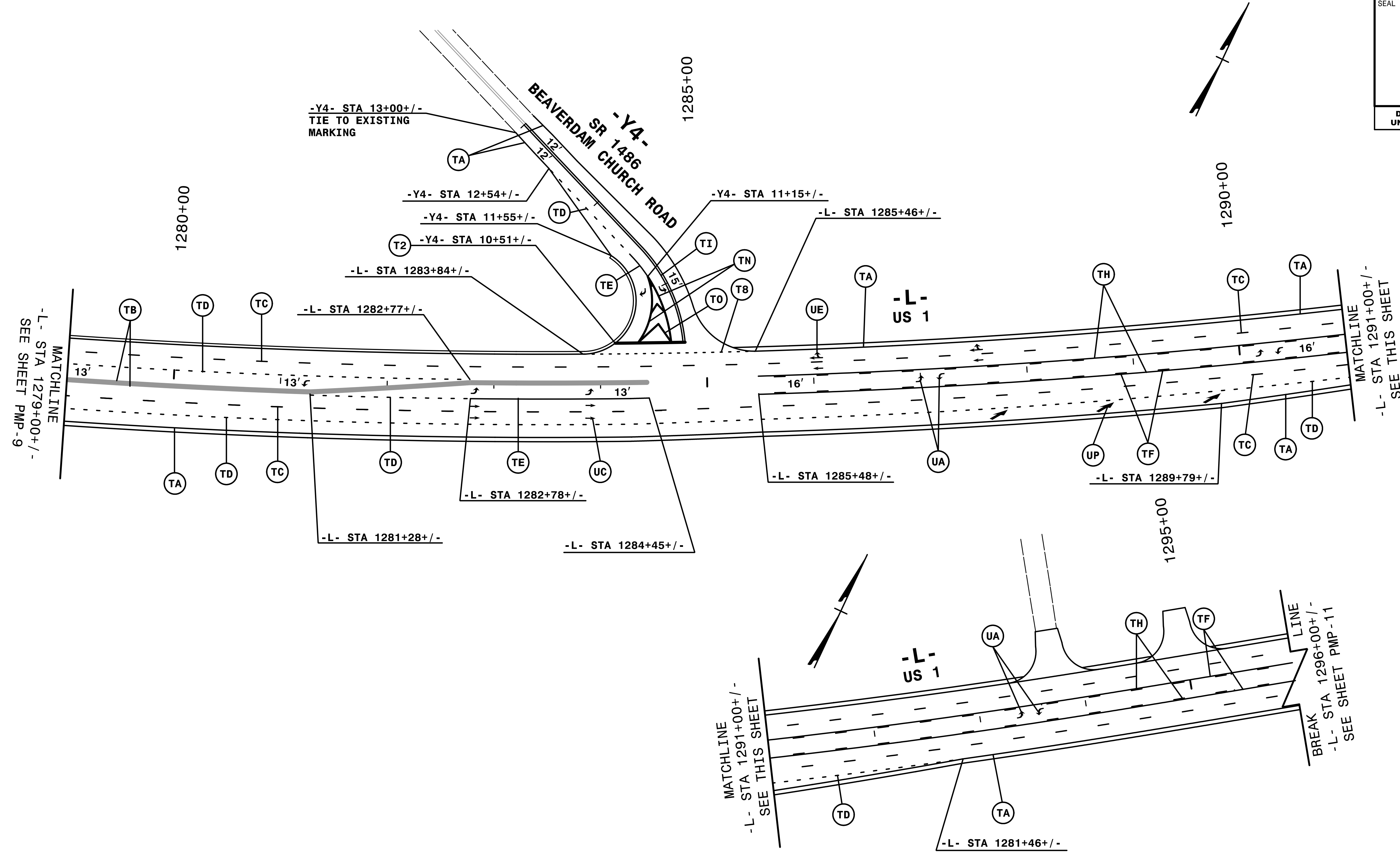

NOTE: ALL LANE WIDTHS ARE 12' UNLESS OTHERWISE SHOWN.



ENGINEER TO APPROVE LOCATION OF ALL UNSIGNALIZED STOPBARS.

**HNTB**  
 HNTB NORTH CAROLINA, P.C.  
 343 E. Six Forks Road, Suite 200  
 Raleigh, North Carolina 27609  
 NC License No: C-1554  
 (919) 546-8997

# PAVEMENT MARKING DETAIL

2/5/2018  
2:\1\T-Office\PMR\R2501C\_PMP\_10.dgn  
HNTB

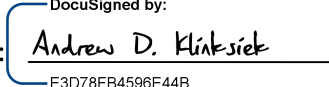

TIP NO. R-2501C	SHEET NO. PMP-11
APPROVED:  <small>E3078F84595E448</small>	
DATE: 2/5/2018	
SEAL 	
DOCUMENT NOT CONSIDERED FINAL UNLESS ALL SIGNATURES COMPLETED	

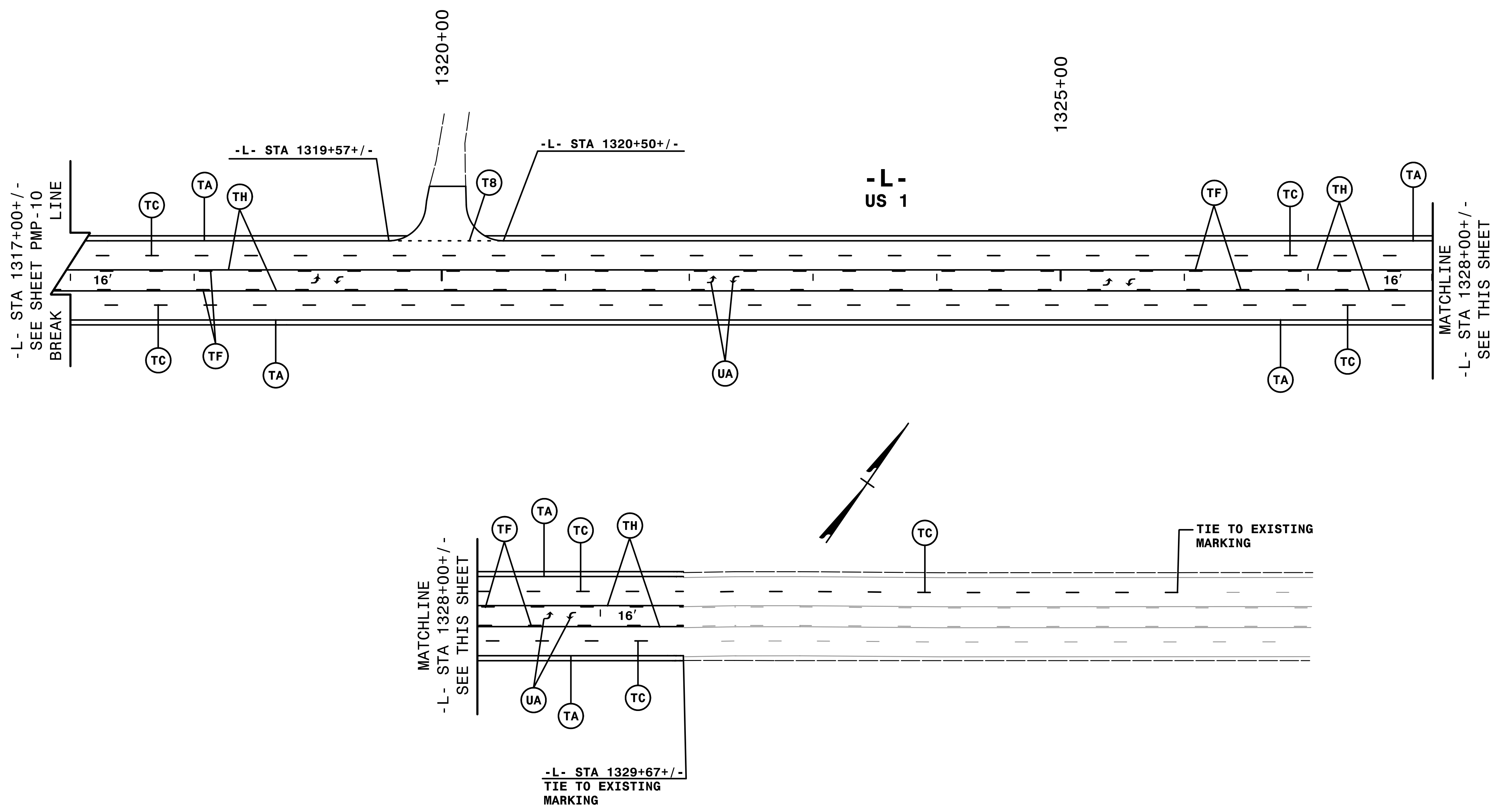

NOTE: ALL LANE WIDTHS ARE 12' UNLESS OTHERWISE SHOWN.

2/5/2018  
T:\Projects\2501C\_PMP\R2501C\_PMP\_01.dgn  
HNTB

**HNTB**  
 HNTB NORTH CAROLINA, P.C.  
 343 E. SIX FORKS ROAD, SUITE 200  
 RALEIGH, NORTH CAROLINA 27609  
 NC LICENSE NO: C-1554  
 (919) 546-8997

# PAVEMENT MARKING DETAIL