

**EDI MODEL MMU2-16LEip  
MALFUNCTION MANAGEMENT UNIT  
PROGRAMMING DETAIL**  
*(program card and tables as shown)*

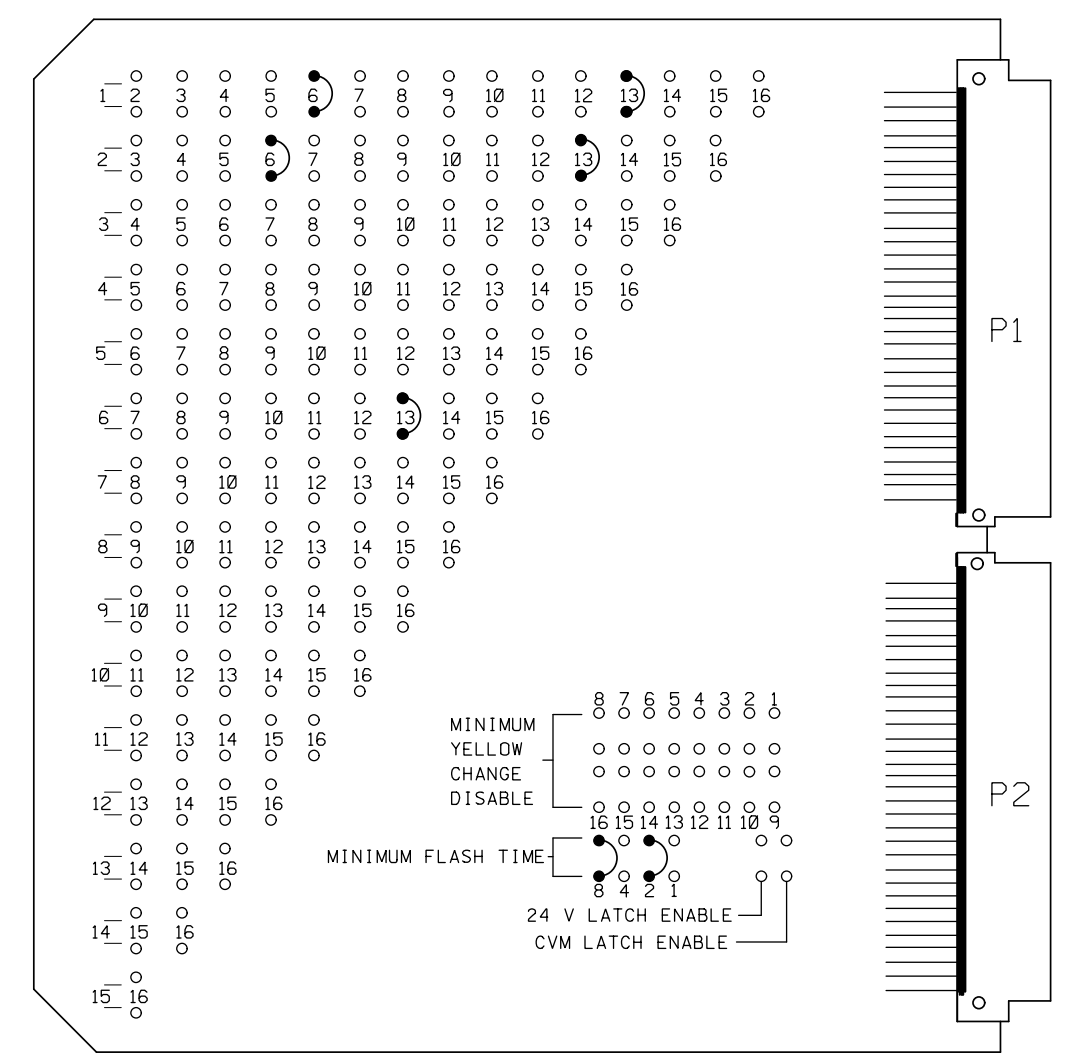

MMU PROGRAMMING CARD

**FIELD CHECK ENABLE  
DUAL IND ENABLE  
RED FAIL ENABLE**

CHANNEL NUMBER	ENABLE/DISABLE
1	DISABLE
2	ENABLE
3	DISABLE
4	DISABLE
5	DISABLE
6	ENABLE
7	DISABLE
8	ENABLE
9	DISABLE
10	DISABLE
11	DISABLE
12	DISABLE
13	ENABLE
14	DISABLE
15	DISABLE
16	DISABLE

**UNIT OPTIONS**

OPTION	SETTING
RECURRENT PULSE	ON
WALK DISABLE	OFF
LOG CVM FAULTS	ON
EXTERN WATCHDOG	OFF
24V-2=12VDC	OFF
PGM CARD MEMORY	ON
LEDguard	ON
FORCE TYPE 16	OFF
TYPE12-SDLC	OFF
VM 3x/Day Latch	ON

**FLASHING YELLOW ARROW**

CONFIG MODE	B
ENABLE CHANNEL PAIR, FYA	
CH 1-13	ON
CH 3-14	OFF
CH 5-15	OFF
CH 7-16	OFF
RED/YEL INPUT ENABLE	
CH 1	ON
CH 3	OFF
CH 5	OFF
CH 7	OFF
FLASH RATE FAULT	ON
FYA TRAP DETECT	ON

**MMU PROGRAMMING NOTE**  
ENSURE YELLOW CHANGE PLUS RED CLEARANCE MONITORING IS ENABLED FOR ALL CHANNELS.

**NOTES**

- To prevent "flash-conflict" problems, wire all unused load switches to flash red. Verify that signal heads flash in accordance with the signal plans.
- To prevent red failures on unused monitor channels, tie unused load switch red outputs 3, 4, 5, 7, 9, 10, 11, 12, 14, 15 and 16 to load switch AC+ by inserting a jumper plug in the unused load switch socket from pin 1 (LS AC+) to pin 3 (RED out). Make sure all flash transfer relays are in place.
- Program controller to start up in phase 2 Green and 6 Green.
- Set power-up flash time to 10 seconds and implement on the Malfunction Management Unit. Set controller power-up flash time to 0 seconds.
- Enable simultaneous gap-out feature for all phases.
- Program detectors in accordance with the manufacturer's instructions to accomplish the detection schemes shown on the signal design plans.
- Program detector call delay and extension timing on the controller, unless otherwise specified.
- Set all detector card unit channels to "presence" mode.
- Program phases 2 and 6 for volume density operation.
- The cabinet and controller are a part of the Cary Signal System.

**SIGNAL HEAD HOOK-UP CHART**

PHASE	1	2	3	4	5	6	7	8	2 PED	4 PED	6 PED	8 PED	OLA	OLB	OLC	OLD
SIGNAL HEAD NO.	11★	21,22	NU	NU	NU	61,62	NU	81,82	NU	NU	NU	NU	11★	NU	NU	NU
RED	*	2R				6R		8R								
YELLOW	*	2Y				6Y		8Y								
GREEN		2G				6G		8G								
RED ARROW													13R			
YELLOW ARROW													13Y			
FLASHING YELLOW ARROW													13G			
GREEN ARROW	1G															

NU = Not Used  
\* Denotes install load resistor. See Load Resistor Installation Detail on sheet 2.  
★ See pictorial of head wiring detail this sheet.

**DETECTOR RACK SET-UP DETAIL**

INSERT DETECTOR CARDS IN RACK ACCORDING TO THE DETAIL SHOWN BELOW. PARTICULAR DETECTOR CHANNELS WILL CALL PHASES INDICATED.

RACK #	BIU	CH1	CH1	CH1	CH1	CH1	CH1	CH1	CH1	CH1	CH1	CH1	CH1	CH1	CH1	CH1	CH1	CH1	CH1	CH1
RACK #1	BIU	L3	L1	L7	SLOT	L11	SLOT	SLOT	SLOT	SLOT	SLOT	SLOT	SLOT	SLOT	SLOT	SLOT	SLOT	SLOT	SLOT	SLOT
		NOT USED	∅ 1	∅ 6		NOT USED														
RACK #2	BIU	CH2	CH2	CH2	E M P T Y	CH2	E M P T Y	E M P T Y	E M P T Y	E M P T Y	E M P T Y	E M P T Y	E M P T Y	E M P T Y	E M P T Y	E M P T Y	E M P T Y	E M P T Y	E M P T Y	E M P T Y
		L4	L2	L8		L12														

**WIRE LOOPS TO TERMINALS ON LOOP PANEL AS SHOWN IN THE CHART BELOW**

LOOP NO.	LOOP PANEL TERMINALS
1A	L1A, L1B L2A, L2B
NU	L3A, L3B
2A	L4A, L4B
NU	L5A, L5B
NU	L6A, L6B
6A	L7A, L7B
NU	L8A, L8B
NU	L9A, L9B
NU	L10A, L10B
NU	L11A, L11B
8A	L12A, L12B
NU	L13A, L13B
NU	L14A, L14B
NU	L15A, L15B
NU	L16A, L16B

**PROGRAM CONTROLLER DETECTORS ACCORDING TO THE SCHEDULE SHOWN IN THE CHART BELOW**

CONTROLLER DETECTOR NO.	FUNCTION	TIMING	
		FEATURE	TIME(SEC)
1	∅ 1	DELAY	15
* 2	∅ 6	DELAY	3
3			
** 4	∅ 2		
5			
6			
* 7	∅ 6		
8			
9			
10			
11			
12	∅ 8		
13			
14			
15			
16			

**WIRE LOOPS TO TERMINALS ON LOOP PANEL AS SHOWN IN THE CHART BELOW**

LOOP NO.	LOOP PANEL TERMINALS
NU	L17A, L17B
NU	L18A, L18B
NU	L19A, L19B
NU	L20A, L20B
NU	L21A, L21B
NU	L22A, L22B
NU	L23A, L23B
NU	L24A, L24B
NU	L25A, L25B
NU	L26A, L26B
NU	L27A, L27B
NU	L28A, L28B
NU	L29A, L29B
NU	L30A, L30B
NU	L31A, L31B
NU	L32A, L32B

**NOTE**  
BE SURE TO PROGRAM DETECTOR TYPES AND TIMERS (EXTEND AND DELAY) AS SHOWN ON THE SIGNAL PLANS.

**EQUIPMENT INFORMATION**

CONTROLLER.....2070LN2  
CABINET .....NC-8 [TS-2]  
SOFTWARE .....ECONOLITE ASC/3-2070  
CABINET MOUNT.....BASE  
LOADBAY POSITIONS.....16  
LOAD SWITCHES USED.....1,2,6,8,13  
PHASES USED.....1,2,6,8  
OLA.....\*  
OLB.....NOT USED  
OLC.....NOT USED  
OLD.....NOT USED  
\* See overlap programming detail on sheet 2

**FYA SIGNAL WIRING DETAIL**  
*(wire signal heads as shown)*

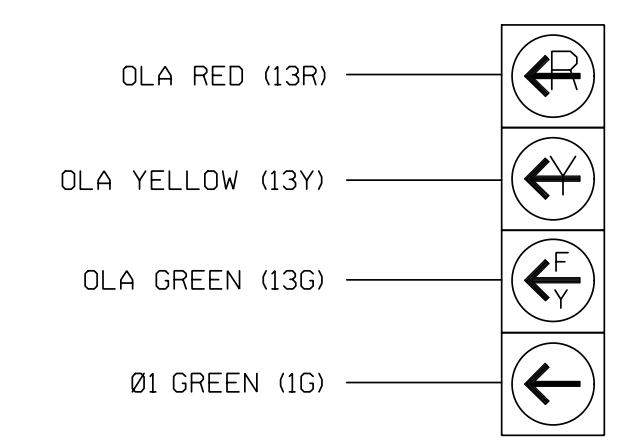

11

**LOAD SWITCH ASSIGNMENT DETAIL**  
*(program controller according to schedule in chart below)*

LOAD SWITCH NUMBER	FUNCTION
1	∅ 1
2	∅ 2
3	∅ 3
4	∅ 4
5	∅ 5
6	∅ 6
7	∅ 7
8	∅ 8
9	∅ 2 PED
10	∅ 4 PED
11	∅ 6 PED
12	∅ 8 PED
13	OLA
14	OLB
15	OLC
16	OLD

THIS ELECTRICAL DETAIL IS FOR THE SIGNAL DESIGN: 05-1533T2  
DESIGNED: APRIL 2016  
SEALED: 9/22/2016  
REVISED: N/A

NC Dept of Transportation  
Division of Highways  
Final Drawing Date: 10/10/2016  
*Signature*  
ITS & Signals Unit

TEMPORARY DESIGN 2 - SHEET 1 OF 2

DOCUMENT NOT CONSIDERED FINAL UNLESS ALL SIGNATURES COMPLETED

PLANS PREPARED IN THE OFFICE OF:  
**Kimley Horn**  
NC License #F-0102  
421 Fayetteville Street, Suite 600  
Raleigh, NC 27601  
(919) 677-2000

Prepared For:

SR 1002 (Aviation Parkway) at SR 3084 (Evans Road)

REVISIONS	INIT.	DATE

SEAL  
NORTH CAROLINA PROFESSIONAL ENGINEER  
SEAL 032607  
STACK L. PHILLIPS  
DATE 9/22/2016  
SIG. INVENTORY NO. 05-1533T2