

5/24/2017 1:05:28 PM G:\Projects\2016\U-2525C (Greensboro Eastern Loop)\Structures\Site Drawings\Final\U2525C_SMU_BR_SITE9.dgn

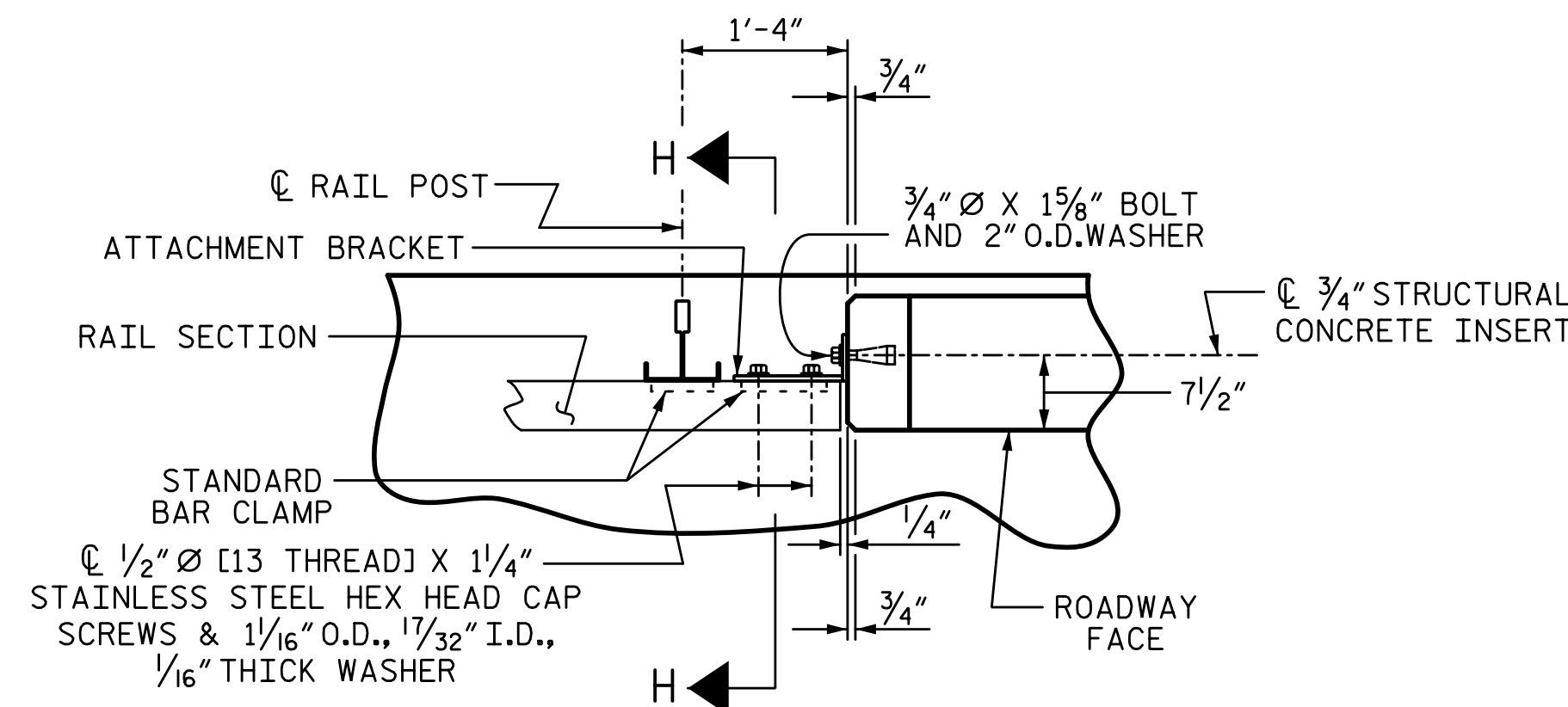

PLAN OF RAIL AND END POST
(STIFFENER ON 1/2" P NOT SHOWN FOR CLARITY)

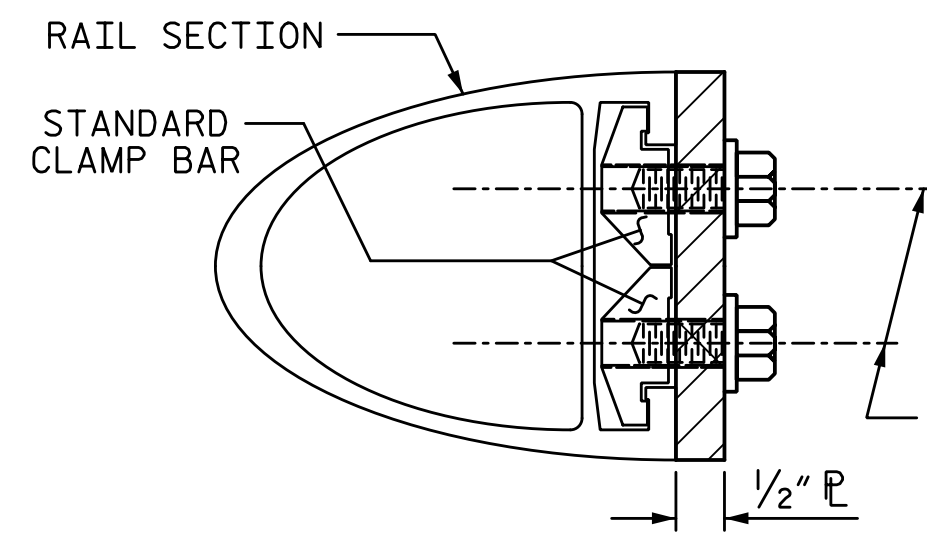

SECTION H-H
(FOR TOP & MIDDLE RAIL)

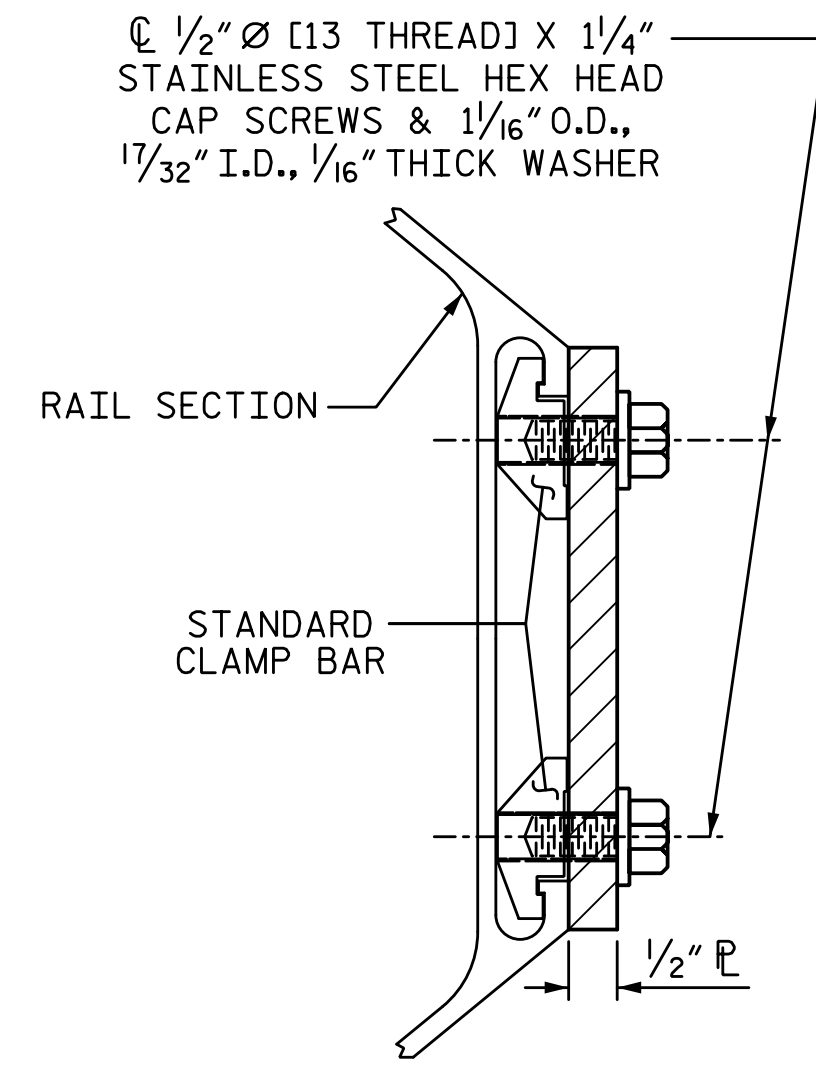

SECTION H-H
(FOR BOTTOM RAIL)

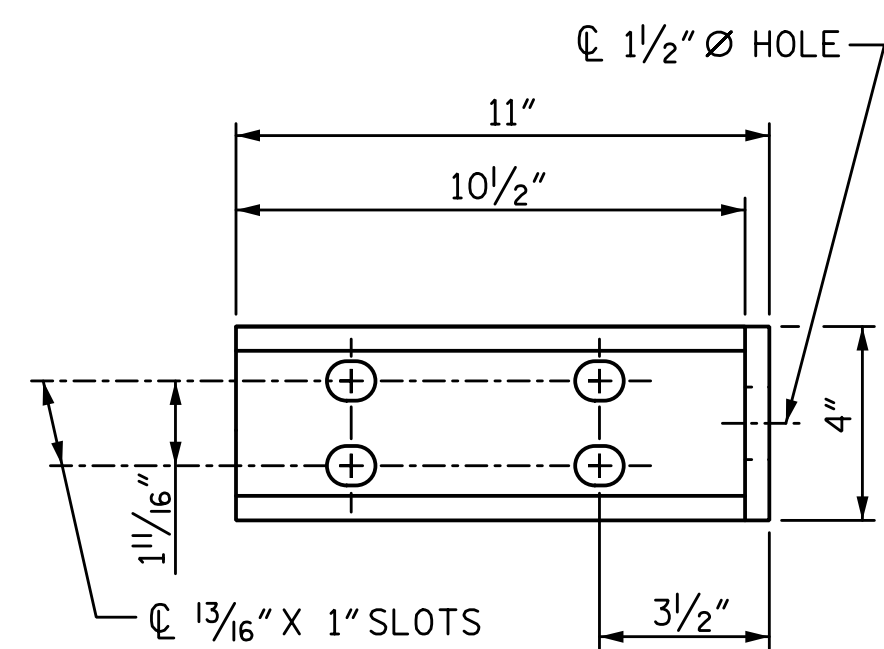

ELEVATION

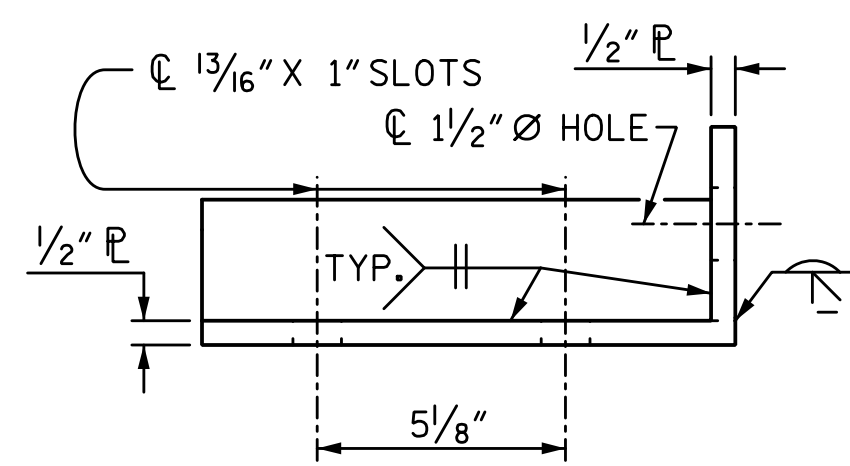

PLAN

ANGLE TO BE MADE FROM
1/2" X 4" X 11" P AND
1/2" X 4" X 4" P

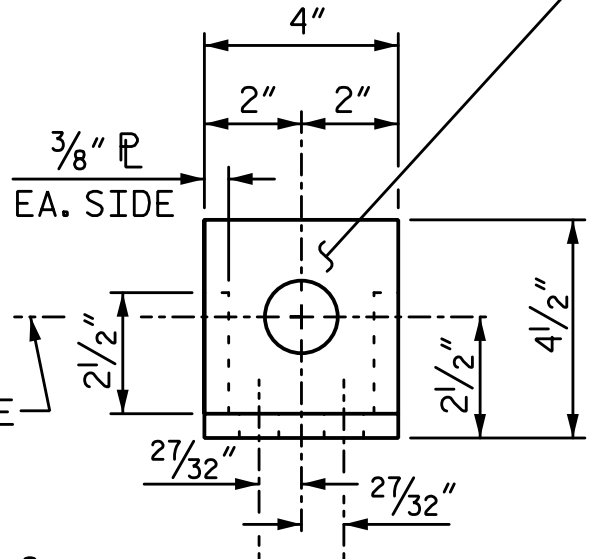

END VIEW
(FIX. AND EXP.)

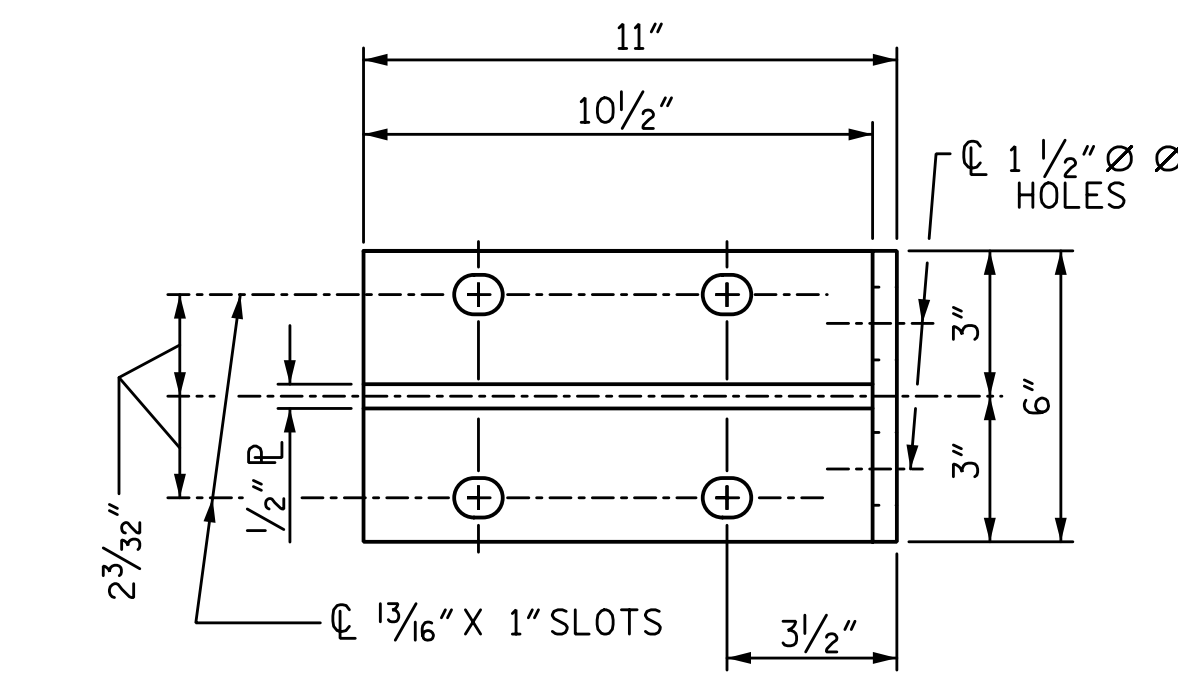

ELEVATION

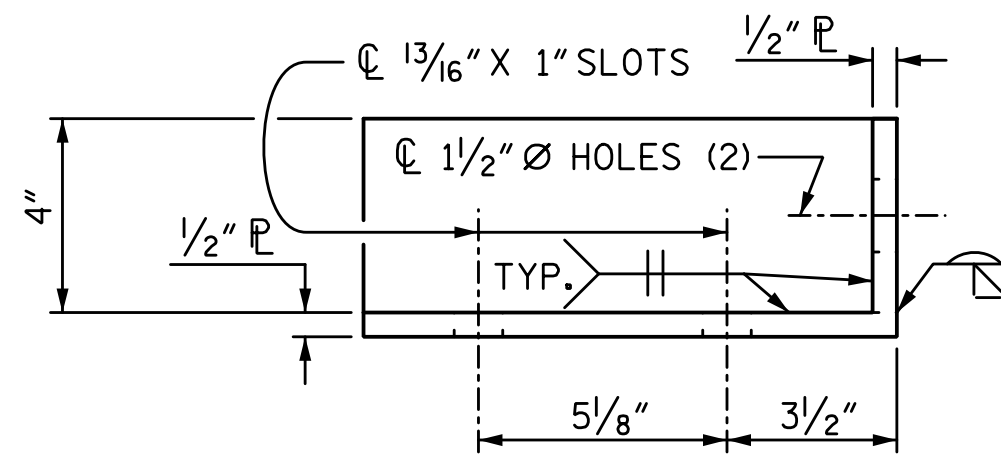

PLAN

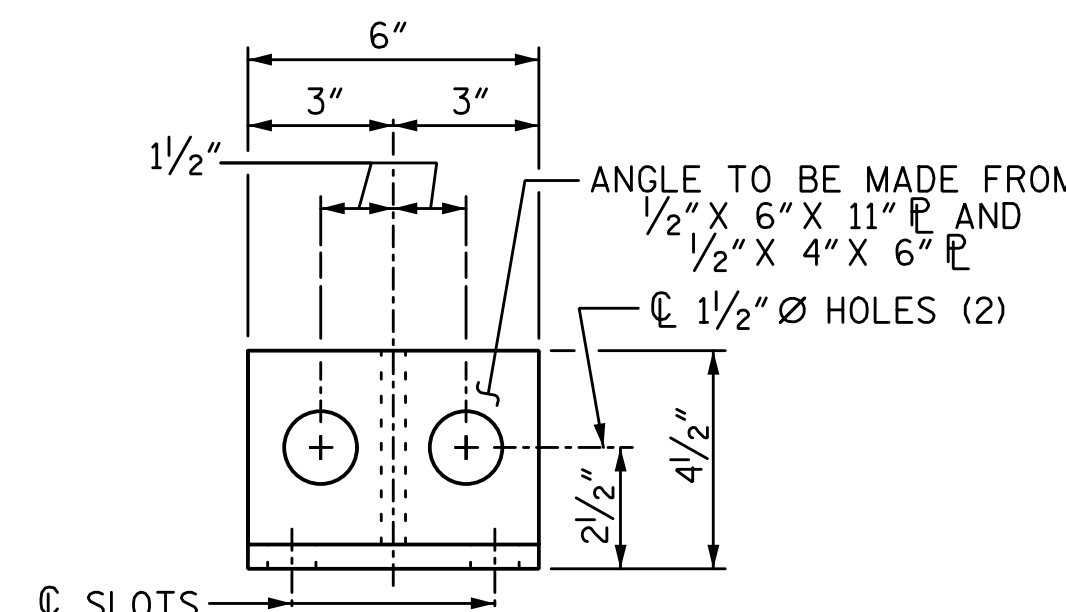

END VIEW

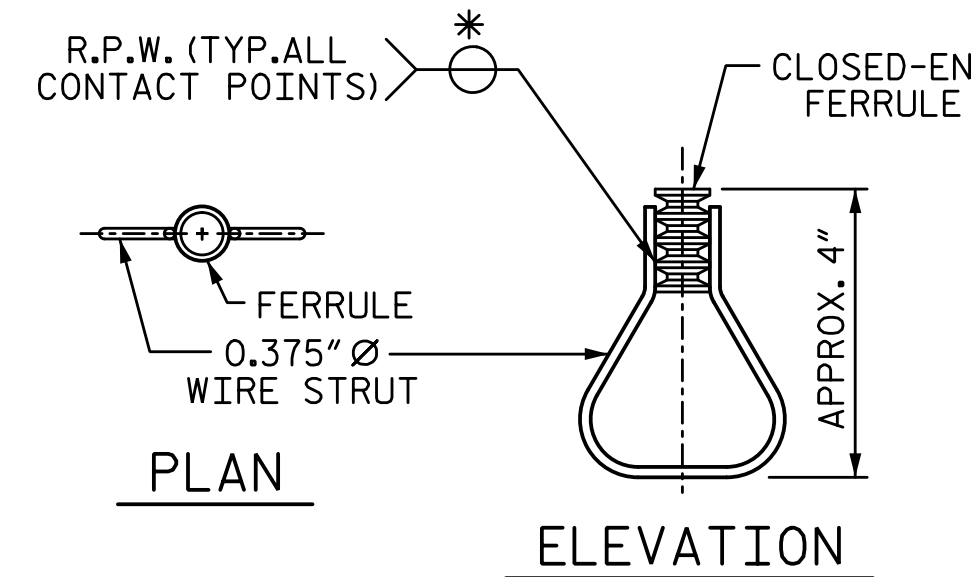

STRUCTURAL CONCRETE INSERT

* EACH WELDED ATTACHMENT OF WIRE TO FERRULE SHALL DEVELOP THE TENSILE STRENGTH OF THE WIRE.

NOTES:

METAL RAIL TO END POST CONNECTION:

THE METAL RAIL TO END POST CONNECTION SHALL CONSIST OF THE FOLLOWING COMPONENTS:

- A. 1/2" PLATES SHALL CONFORM TO AASHTO M270 GRADE 36 AND SHALL BE GALVANIZED AFTER FABRICATION.
- B. 3/4" STRUCTURAL CONCRETE INSERT SHALL HAVE A WORKING LOAD SHEAR CAPACITY OF 4800 LBS. THE FERRULES SHALL ENGAGE A 3/4" X 1 5/8" BOLT WITH 2" O.D. WASHER IN PLACE. THE 3/4" X 1 5/8" BOLT SHALL HAVE N.C. THREADS.
- C. CAP SCREWS FOR RAIL ATTACHMENT TO ANGLE SHALL CONFORM TO THE REQUIREMENTS OF ASTM F593 ALLOY 305 STAINLESS STEEL. CAP SCREWS TO BE CENTERED IN SLOTS AT 60°F. WASHERS FOR RAIL ATTACHMENT SHALL MEET THE REQUIREMENTS OF ASTM F844 EXCEPT THEY SHALL BE MADE FROM ALLOY 304 STAINLESS STEEL.
- D. STANDARD CLAMP BARS ("3 BAR METAL RAIL" SHEET 2 OF 3).

THE COST OF THE STANDARD CLAMP BARS AND CAP SCREWS USED IN THE METAL RAIL TO END POST CONNECTION SHALL BE INCLUDED IN THE UNIT CONTRACT PRICE BID FOR LINEAR FEET OF 3 BAR METAL RAIL.

THE 3/4" STRUCTURAL CONCRETE INSERT WITH BOLT SHALL BE ASSEMBLED IN THE SHOP.

THE COST OF THE 3/4" STRUCTURAL CONCRETE INSERT ASSEMBLY, AND THE 1/2" PLATES COMPLETE IN PLACE SHALL BE INCLUDED IN THE VARIOUS PAY ITEMS.

THE CONTRACTOR, AT HIS OPTION, MAY USE AN ADHESIVE BONDING SYSTEM IN LIEU OF THE STRUCTURAL CONCRETE INSERT EMBEDDED IN THE END POST. IF THE ADHESIVE BONDING SYSTEM IS USED, THE 3/4" X 1 5/8" BOLT WITH WASHER SHALL BE REPLACED WITH A 3/4" X 6 1/2" BOLT AND 2" O.D. WASHER. ALL SPECIFICATIONS THAT APPLY TO THE 3/4" X 1 5/8" BOLT SHALL APPLY TO THE 3/4" X 6 1/2" BOLT. FIELD TESTING OF THE ADHESIVE BONDING SYSTEM IS NOT REQUIRED.

NOTES:

STRUCTURAL CONCRETE INSERT:

THE STRUCTURAL CONCRETE INSERT ASSEMBLY SHALL CONSIST OF THE FOLLOWING COMPONENTS:

- A. FERRULES SHALL BE MADE FROM STEEL MEETING THE REQUIREMENTS OF AASHTO M169, GRADE 12L14 AND SHALL HAVE A MINIMUM LENGTH OF THREADS OF 1 1/2".
- B. 1 - 3/4" X 1 5/8" BOLT WITH WASHER. BOLT SHALL CONFORM TO THE REQUIREMENTS OF ASTM A307. BOLT AND WASHER SHALL BE GALVANIZED. AT THE CONTRACTORS OPTION, STAINLESS STEEL BOLT AND WASHER MAY BE USED AS AN ALTERNATE FOR THE 3/4" X 1 5/8" GALVANIZED BOLT AND WASHER. THEY SHALL CONFORM TO OR EXCEED THE MECHANICAL REQUIREMENTS OF ASTM A307. THE USE OF THIS ALTERNATE SHALL BE APPROVED BY THE ENGINEER.
- C. WIRE STRUT SHOWN IN THE CONCRETE INSERT ASSEMBLY DETAIL IS THE MINIMUM ALLOWABLE SIZE AND SHALL HAVE A MINIMUM TENSILE STRENGTH OF 100,000 PSI. AS AN OPTION, A 1/16" WIRE STRUT WITH A MINIMUM TENSILE STRENGTH OF 90,000 PSI IS ACCEPTABLE.

DETAILS FOR ATTACHMENT BRACKET

(TOP & MIDDLE RAIL ONLY)

DETAILS FOR ATTACHMENT BRACKET

(BOTTOM RAIL ONLY)

DRAWN BY: S.D. COOPER	DATE: 3-17
CHECKED BY: T.J. BEACH	DATE: 3-17
DESIGN ENGINEER OF RECORD: T.J. BEACH	DATE: 3-17

PLANS PREPARED BY:

 5640 Dillard Drive
 Suite 200
 Cary, NC 27518
 (919) 852-0468
 (919) 852-0538 (Fax)
 www.simpsonengr.com
 LICENSURE NO. C-2521

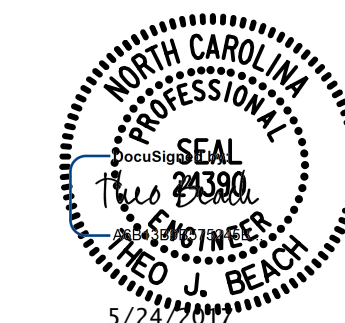

PROJECT NO. U-2525C
GUILFORD COUNTY
 STATION: 25+52.71 -Y7-

SHEET 3 OF 3

STATE OF NORTH CAROLINA
 DEPARTMENT OF TRANSPORTATION
 RALEIGH
 SUPERSTRUCTURE

3 BAR METAL RAIL

REVISIONS						SHEET NO.
NO.	BY:	DATE:	NO.	BY:	DATE:	S10-19
1			3			TOTAL SHEETS
2			4			36

**DOCUMENT NOT CONSIDERED FINAL
 UNLESS ALL SIGNATURES COMPLETED**