

NOTES:

"U" BARS IN CAP AND FOOTING MAY BE SHIFTED AS NECESSARY TO CLEAR ANCHOR BOLTS.

BACKWALL SHALL BE PLACED BEFORE APPLYING THE EPOXY PROTECTIVE COATING.

THE TOP SURFACE AREAS OF THE END BENT CAP SHALL BE CURED IN ACCORDANCE WITH THE STANDARD SPECIFICATIONS EXCEPT THE MEMBRANE CURING COMPOUND METHOD SHALL NOT BE USED.

THE TOP SURFACE OF THE CAP EXCEPT THE BRIDGE SEAT BUILDUPS SHALL BE SLOPED TRANSVERSELY FROM THE FILL FACE TO THE FRONT FACE AT THE RATE OF 2%.

THE CONCRETE IN THE SHADED AREA OF THE WING SHALL BE POURED AFTER THE JOINT BETWEEN THE DECK AND APPROACH SLAB HAS BEEN SAWED AND THE BARRIER RAIL IS CAST IF SLIP FORMING IS USED.

THE WING WALLS ARE DETAILED TO FIT WITH MSE WALL COPING DETAIL A AS SHOWN ON THE SLOPE PROTECTION DETAIL SHEET. IF MSE WALL COPING DETAIL B IS USED, WING WALLS SHALL BE SHORTENED TO FIT. COORDINATE WITH THE MSE WALL FABRICATOR FOR COPING DETAIL TO BE USED. H BAR LENGTHS AND V BAR POSITIONS SHALL BE ADJUSTED TO FIT FINAL WINGWALL LENGTHS.

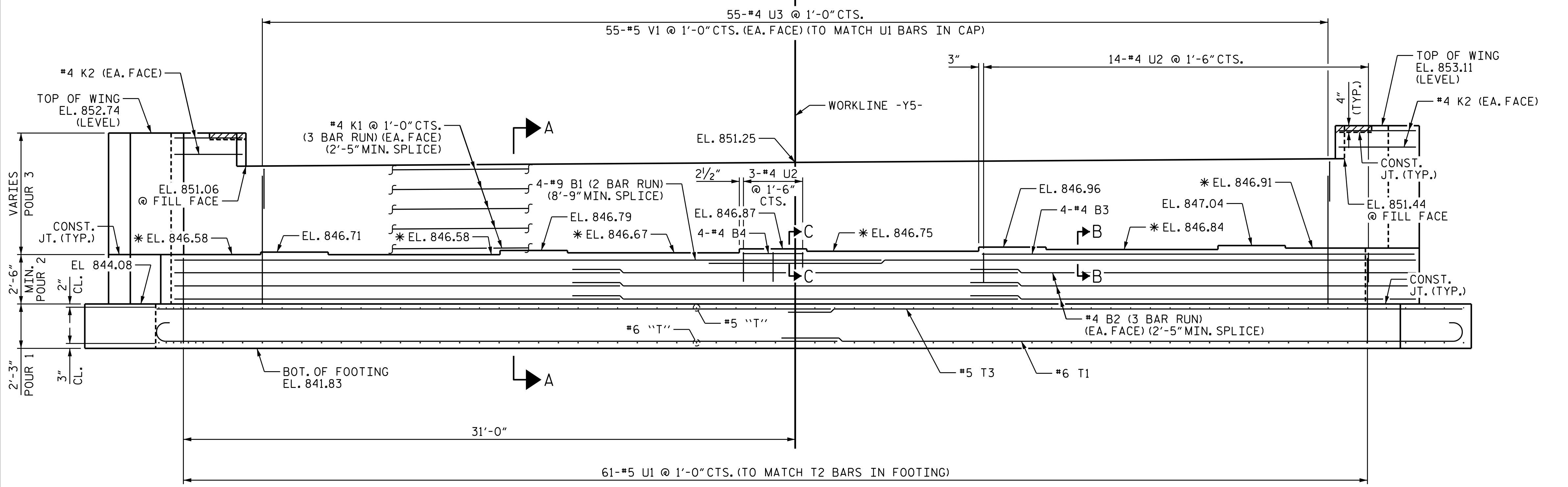
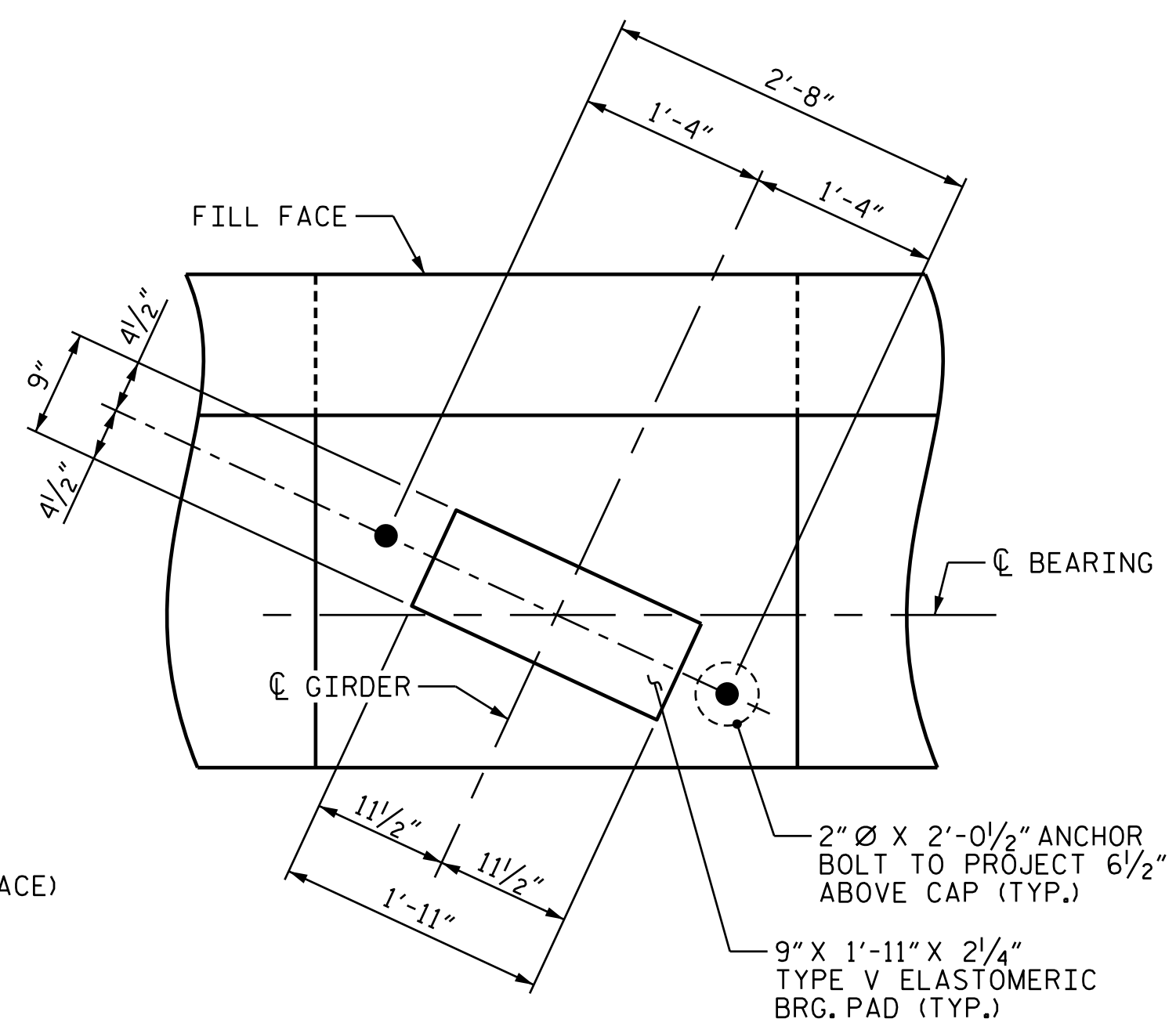

WING W4 NOT SHOWN FOR CLARITY

* FOR LOCATION ON CAP SEE SHEET 3 OF 3

PROJECT NO. U-2525C
 GUILFORD COUNTY
 STATION: 22+29.98 -Y5-

SHEET 1 OF 3

STATE OF NORTH CAROLINA
 DEPARTMENT OF TRANSPORTATION
 RALEIGH
 SUBSTRUCTURE
 END BENT 2

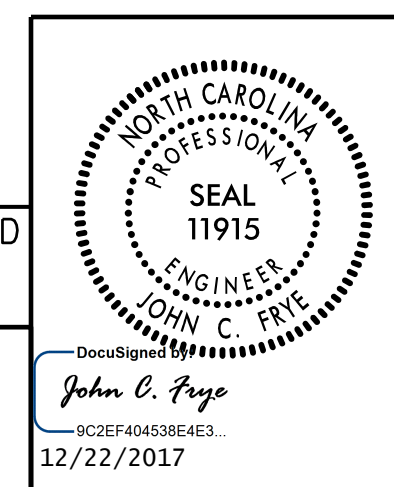

DOCUMENT NOT CONSIDERED FINAL UNLESS ALL SIGNATURES COMPLETED

PLANS PREPARED BY: MOTT MACDONALD

PO Box 700
 Fuquay-Varina, NC 27526
 (919) 552-2253
 www.mottmac.com
 LICENSE NO. F-0669

REVISIONS COMPLETED						SHEET NO.
NO.	BY:	DATE:	NO.	BY:	DATE:	S7-23
1			3			TOTAL SHEETS
2			4			28

#157077
 #12/21/2017 12:21:20 PM
 C:\Users\Y5_Nor-th_Church-St\Plans\U-2525C-SMU.E2_4012146.dgn
 3:38:05 PM

DRAWN BY: R. H. BRAINARD DATE: 11-2017
 CHECKED BY: J. E. MONDOLFI DATE: 11-2017
 DESIGN ENGINEER OF RECORD: J. E. MONDOLFI DATE: 12-2017