

PLAN OF SPAN B

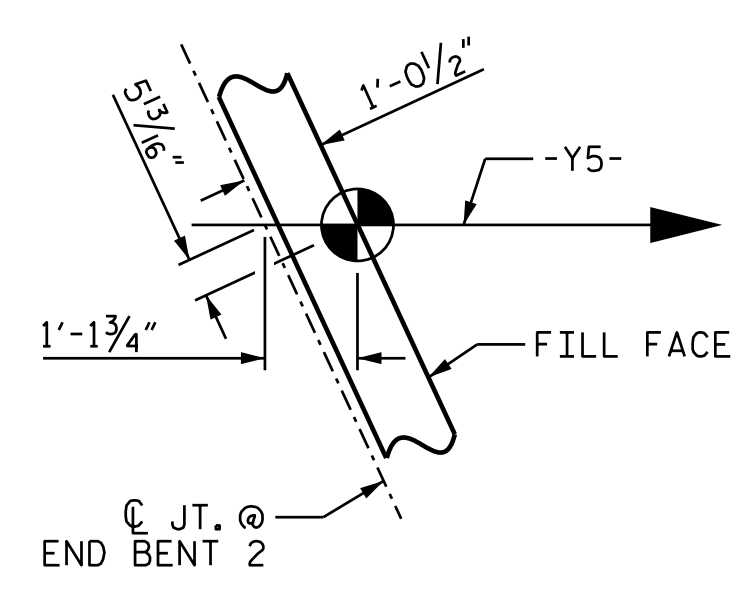

DETAIL B

PROJECT NO. U-2525C
GUILFORD COUNTY
 STATION: 22+29.98 -Y5-

SHEET 2 OF 2

STATE OF NORTH CAROLINA
 DEPARTMENT OF TRANSPORTATION
 RALEIGH
 SUPERSTRUCTURE
 PLAN OF SPAN B

REVISIONS						SHEET NO.
NO.	BY:	DATE:	NO.	BY:	DATE:	S7-8
1			3			TOTAL SHEETS
2			4			28

DOCUMENT NOT CONSIDERED
 FINAL UNLESS ALL
 SIGNATURES COMPLETED

PLANS PREPARED BY:
M MOTT MACDONALD
 PO Box 700
 Fuquay-Varina, NC 27526
 (919) 552-2253
 www.mottmac.com
 LICENSE NO. F-0669

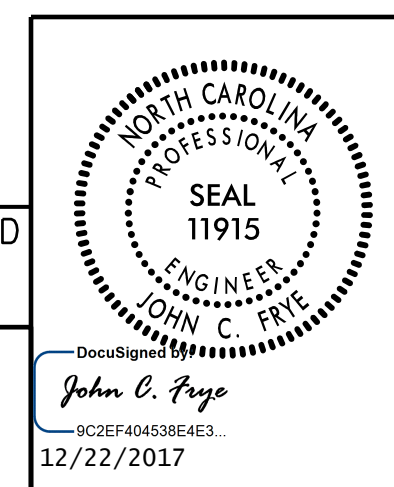

12/21/2017 3:37:22 PM
 C:\Users\Y5-North-Church-St\Plans\U-2525C-SMU-S-401246.dgn
 157077

DRAWN BY: R. H. BRAINARD DATE: 9-2017
 CHECKED BY: J. E. MONDOLFI DATE: 11-2017
 DESIGN ENGINEER OF RECORD: J. E. MONDOLFI DATE: 12-2017