

PLAN @ END BENT 1 PLAN @ END BENT 2

DIMENSIONS SHOWN ARE TYPICAL FOR BOTH APPROACH SLABS

NOTES
 APPROACH SLAB SHALL NOT BE CONSTRUCTED PRIOR TO COMPLETION OF THE BRIDGE DECK.
 AREA BETWEEN THE WINGWALL AND APPROACH SLAB SHALL BE GRADED TO DRAIN THE WATER AWAY FROM THE FILL FACE OF THE BRIDGE AND SHALL BE PAVED. SEE ROADWAY PLANS.
 FOR EXPANSION JOINT SEALS, SEE SPECIAL PROVISIONS.

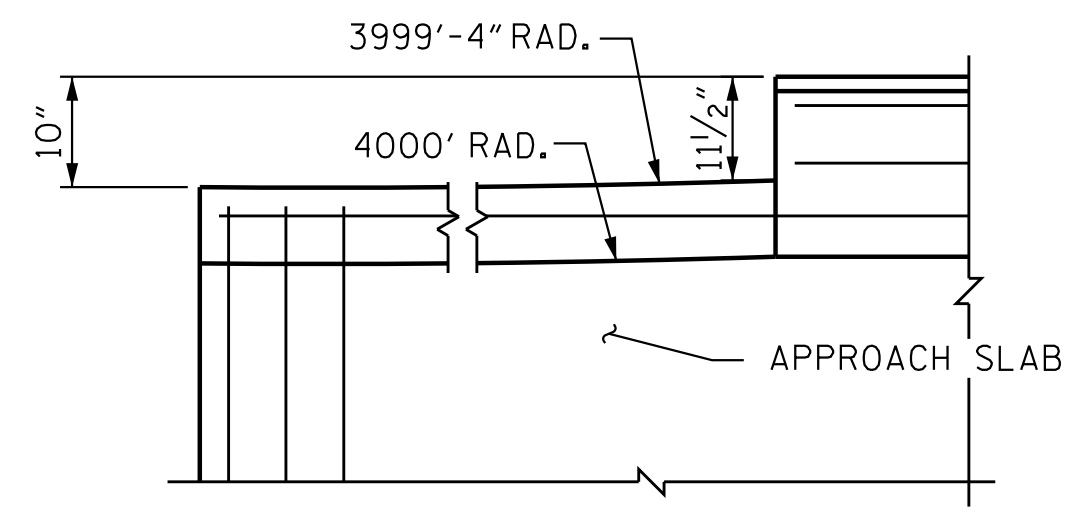

DETAIL A
 APPROACH SLAB AT END BENT 1 SHOWN.
 APPROACH SLAB AT END BENT 2 SIMILAR BY ROTATION

SPLICE LENGTHS

BAR SIZE	EPOXY COATED	UNCOATED
#4	2'-0"	1'-9"
#5	2'-6"	2'-2"
#6	3'-10"	2'-7"

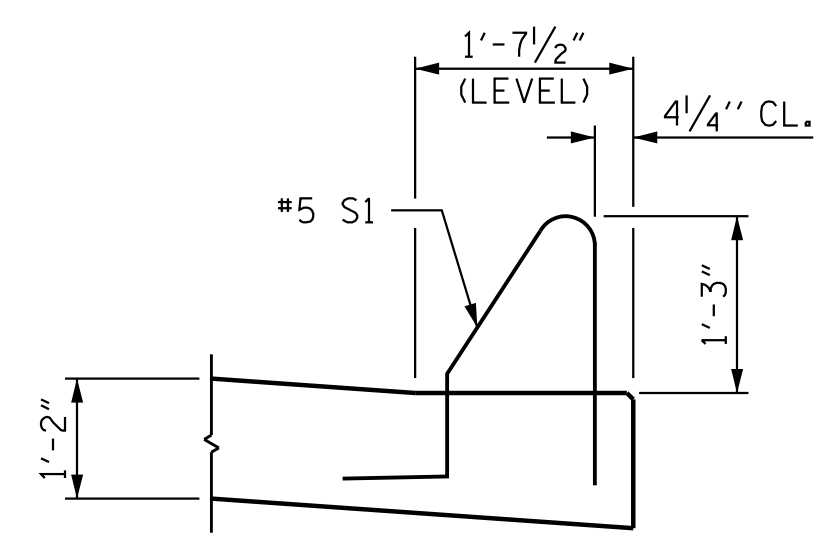

SECTION K-K
 (FOR BARRIER RAIL DIMENSIONS AND REINFORCING STEEL DETAIL, SEE CONCRETE BARRIER RAIL SHEET)

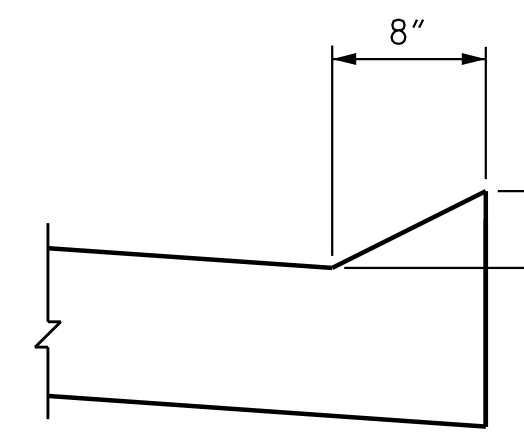

SECTION M-M

CURB DETAILS

BILL OF MATERIAL

APPROACH SLAB AT EB 1					
BAR	NO.	SIZE	TYPE	LENGTH	WEIGHT
*A1	72	#4	STR	22'-8"	1090
A2	72	#4	STR	22'-6"	1082
*B1	125	#5	STR	23'-9"	3096
B2	125	#6	STR	24'-8"	4631
*B3	4	#5	STR	9'-7"	40
B4	4	#6	STR	9'-7"	58
*J1	61	#4	1	1'-5"	58
REINFORCING STEEL **					LBS. 5771
*EPOXY COATED REINFORCING STEEL **					LBS. 4284
CLASS AA CONCRETE **					C.Y. 68.4

APPROACH SLAB AT EB 2					
BAR	NO.	SIZE	TYPE	LENGTH	WEIGHT
*A1	72	#4	STR	22'-8"	1090
A2	72	#4	STR	22'-6"	1082
*B1	125	#5	STR	23'-9"	3096
B2	125	#6	STR	24'-8"	4631
*B3	4	#5	STR	9'-7"	40
B4	4	#6	STR	9'-7"	58
*J1	61	#4	1	1'-5"	58
REINFORCING STEEL **					LBS. 5771
*EPOXY COATED REINFORCING STEEL **					LBS. 4284
CLASS AA CONCRETE **					C.Y. 68.4

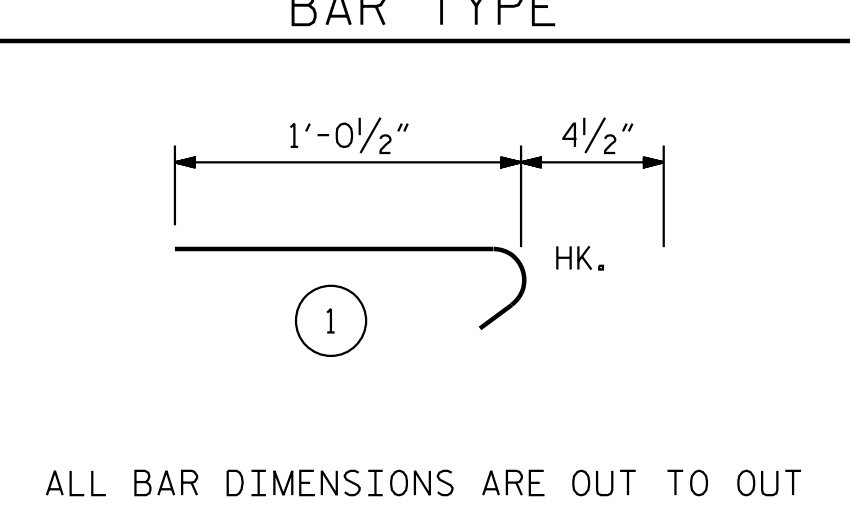

ALL BAR DIMENSIONS ARE OUT TO OUT
 ** QUANTITIES FOR BARRIER RAIL ARE NOT INCLUDED. SEE CONCRETE BARRIER RAIL SHEET.

THE QUANTITY OF #4 J1 BARS ON THE BILL OF MATERIAL IS BASED ON 1'-0" CENTERS. J1 BARS SHALL BE PLACED AT EACH VERTICAL STUD ANCHOR BOLT. IN THE EVENT THAT THE NUMBER OF VERTICAL STUD ANCHORS EXCEEDS THE NUMBER OF J1 BARS SPECIFIED, ADDITIONAL J1 BARS WILL NOT BE REQUIRED.

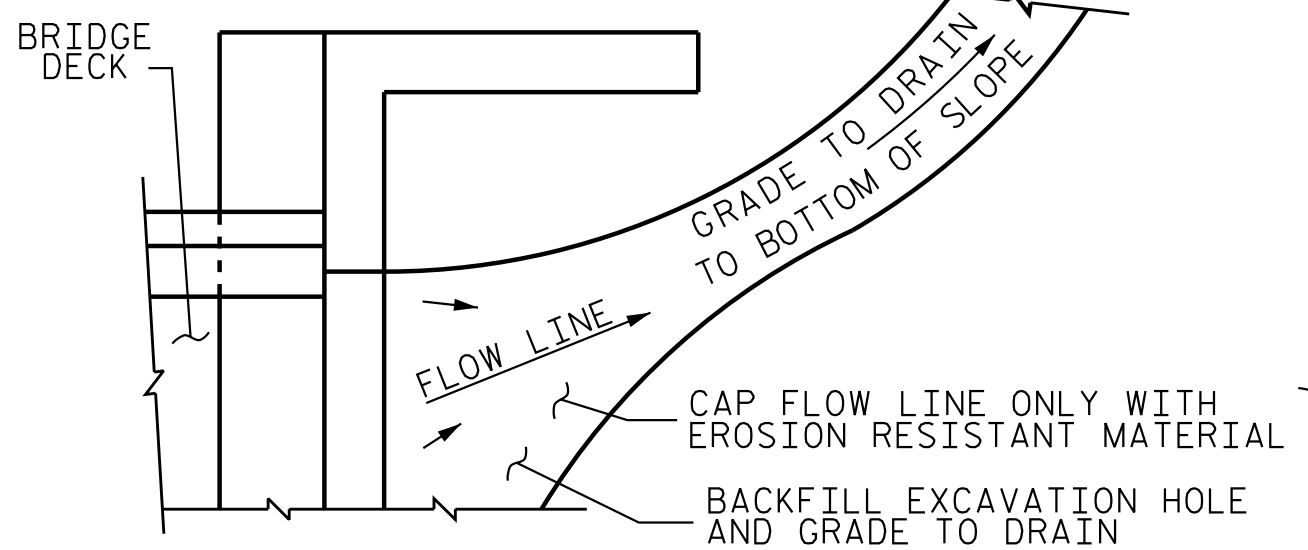

NOTE: IF THE APPROACH SLAB IS NOT CONSTRUCTED IMMEDIATELY AFTER THE BACKFILLING OF THE END BENT EXCAVATION, GRADE TO DRAIN TO THE BOTTOM OF THE SLOPE AND PROVIDE EROSION RESISTANT MATERIAL, SUCH AS FIBERGLASS ROVING OR AS DIRECTED BY THE ENGINEER TO PREVENT SOIL EROSION AND TO PROTECT THE AREA ADJACENT TO THE STRUCTURE. THE CONTRACTOR WILL BE REQUIRED TO REMOVE THESE MATERIALS PRIOR TO CONSTRUCTION OF THE APPROACH SLAB.

TEMPORARY DRAINAGE DETAIL

TEMPORARY BERM AND SLOPE DRAIN DETAILS

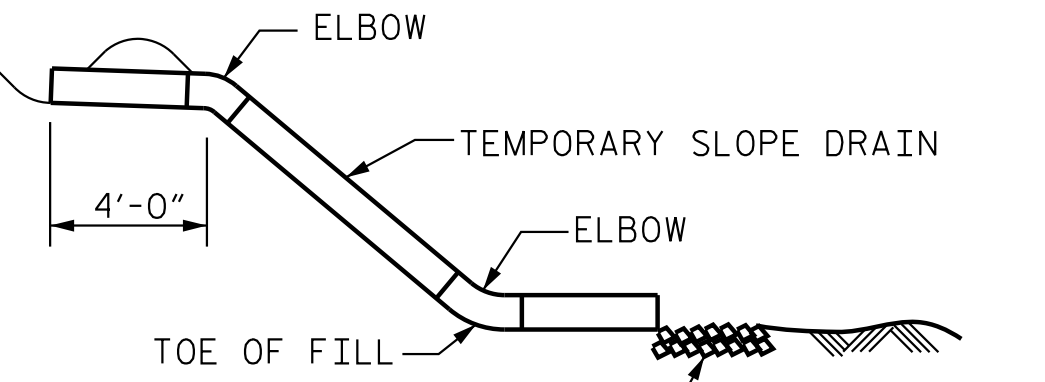

SECTION R-R

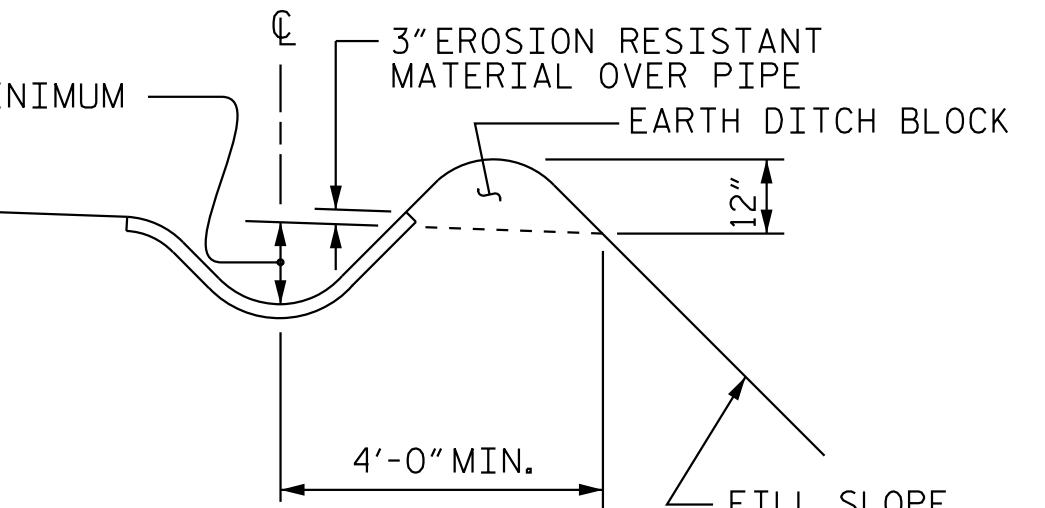

SECTION S-S

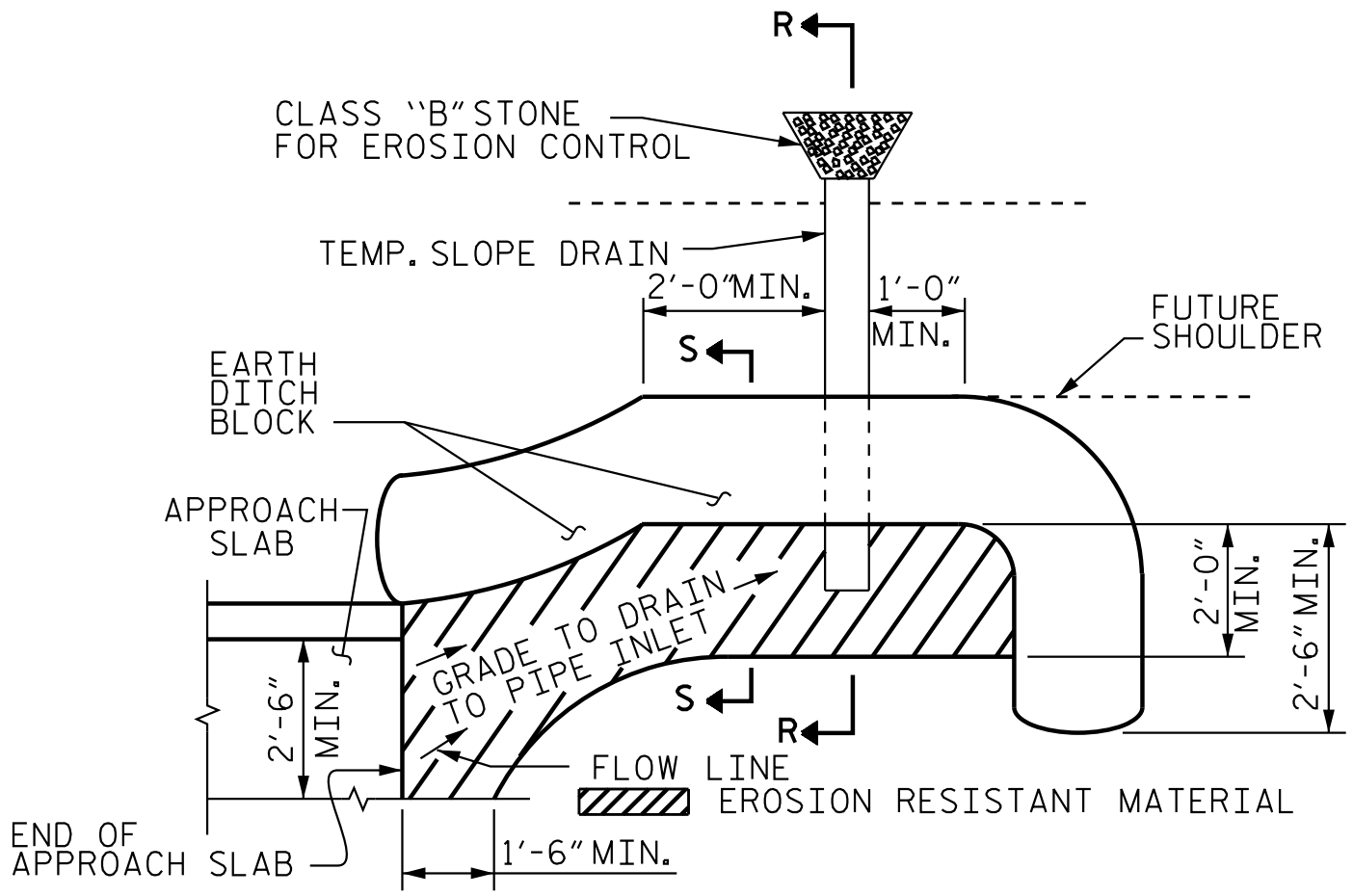

NOTE: IMMEDIATELY AFTER THE CONSTRUCTION OF THE APPROACH SLAB, THE CONTRACTOR SHALL PROVIDE TEMPORARY BERM AND SLOPE DRAIN. CONTRACTOR SHALL GRADE TO PIPE INLET AND PROVIDE EROSION RESISTANT MATERIAL AS SHOWN. THE EROSION RESISTANT MATERIAL SHALL BE EITHER 1) ASPHALT PLANT MIX, TYPE 1 OR TYPE 2, MIN. 2" DEPTH, 2) EROSION CONTROL MAT, OR 3) CONCRETE, AS DIRECTED BY THE ENGINEER. THE SLOPE DRAIN SHALL CONSIST OF A NON-PERFORATED TEMPORARY DRAINAGE PIPE, 12 INCHES IN DIAMETER.

PLAN VIEW

Stantec Consulting Services Inc.
 801 Jones Franklin Road
 Suite 300
 Raleigh, NC 27606
 Tel. (919) 851-6866
 Fax. (919) 851-7024
 www.stantec.com
 License No. F-0672

DRAWN BY: J. B. GEILE DATE: 12/08/16
 CHECKED BY: N. D'AUTO DATE: 01/03/17
 DESIGN ENGINEER OF RECORD: T. R. DUDECK DATE: 01/12/18

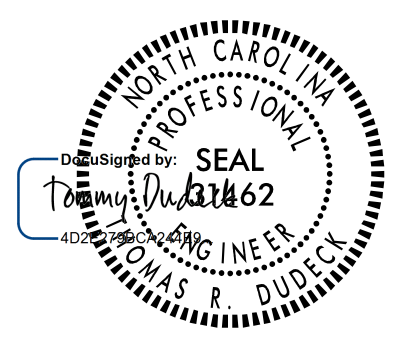

1/12/2018

DOCUMENT NOT CONSIDERED FINAL UNLESS ALL SIGNATURES COMPLETED

PROJECT NO. U-2525C
 GUILFORD COUNTY
 STATION: 329+95.42 -L-

SHEET 1 OF 2

REVISIONS						SHEET NO.
NO.	BY:	DATE:	NO.	BY:	DATE:	S3-28
1			3			TOTAL SHEETS 29
2			4			