

Note:
1. Opening in pole base plate shall be equal to pole base inside diameter minus 3 1/2" but shall not be less than 8 1/2".

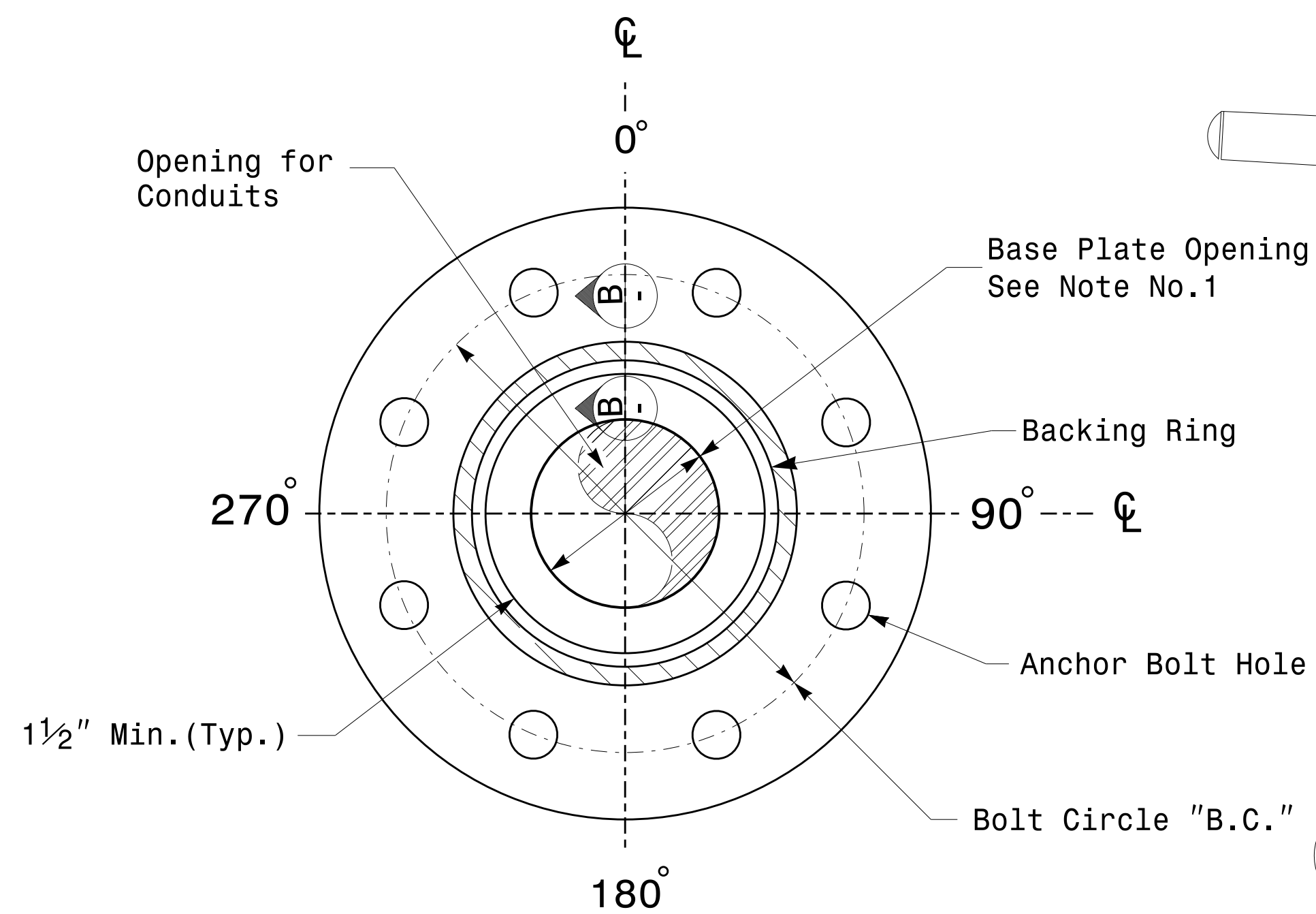

Section A-A
Pole Base Plate Details

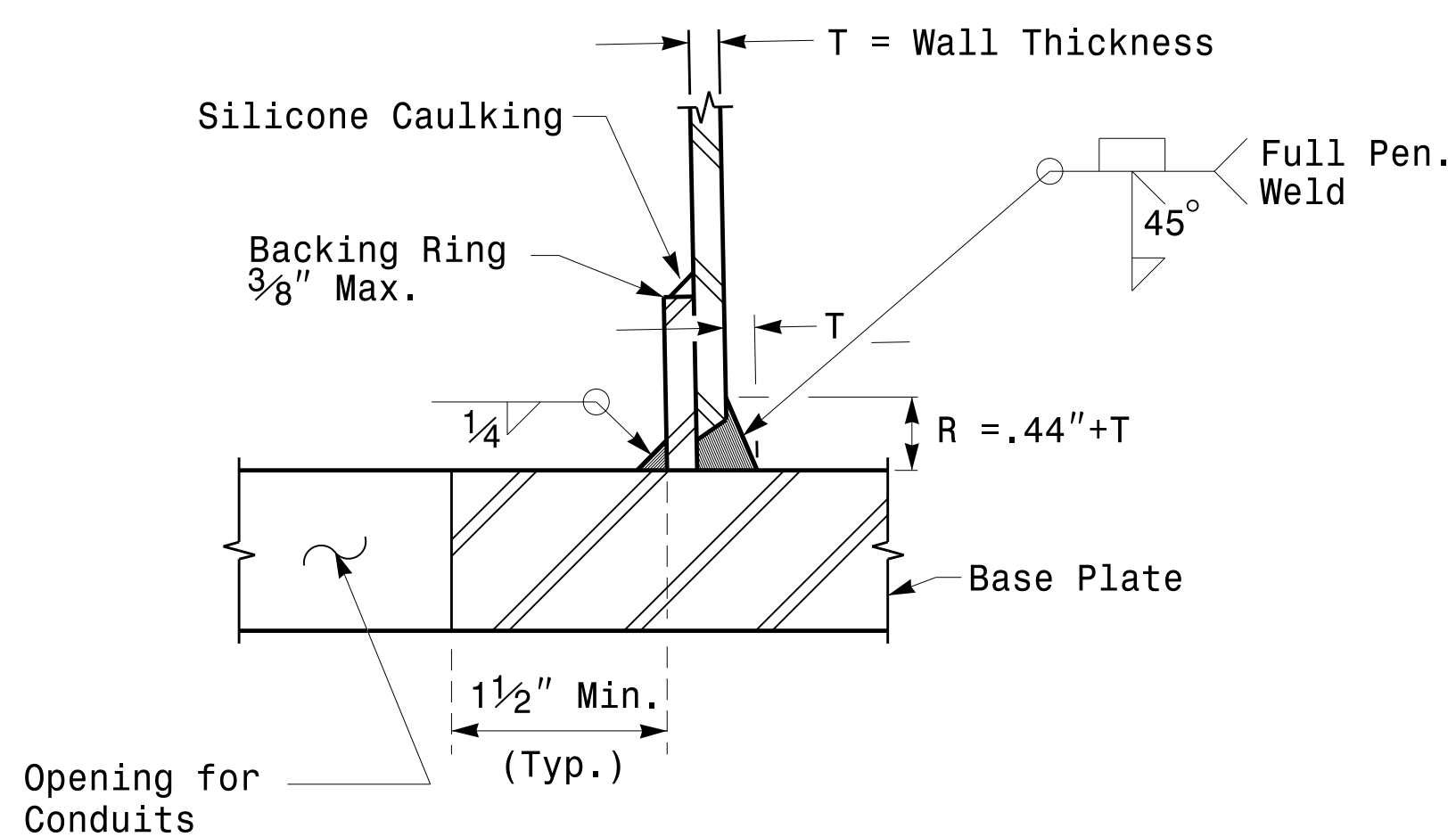

Section B-B
(Pole Attachment to Base Plate)
Full-Penetration Groove Weld Detail

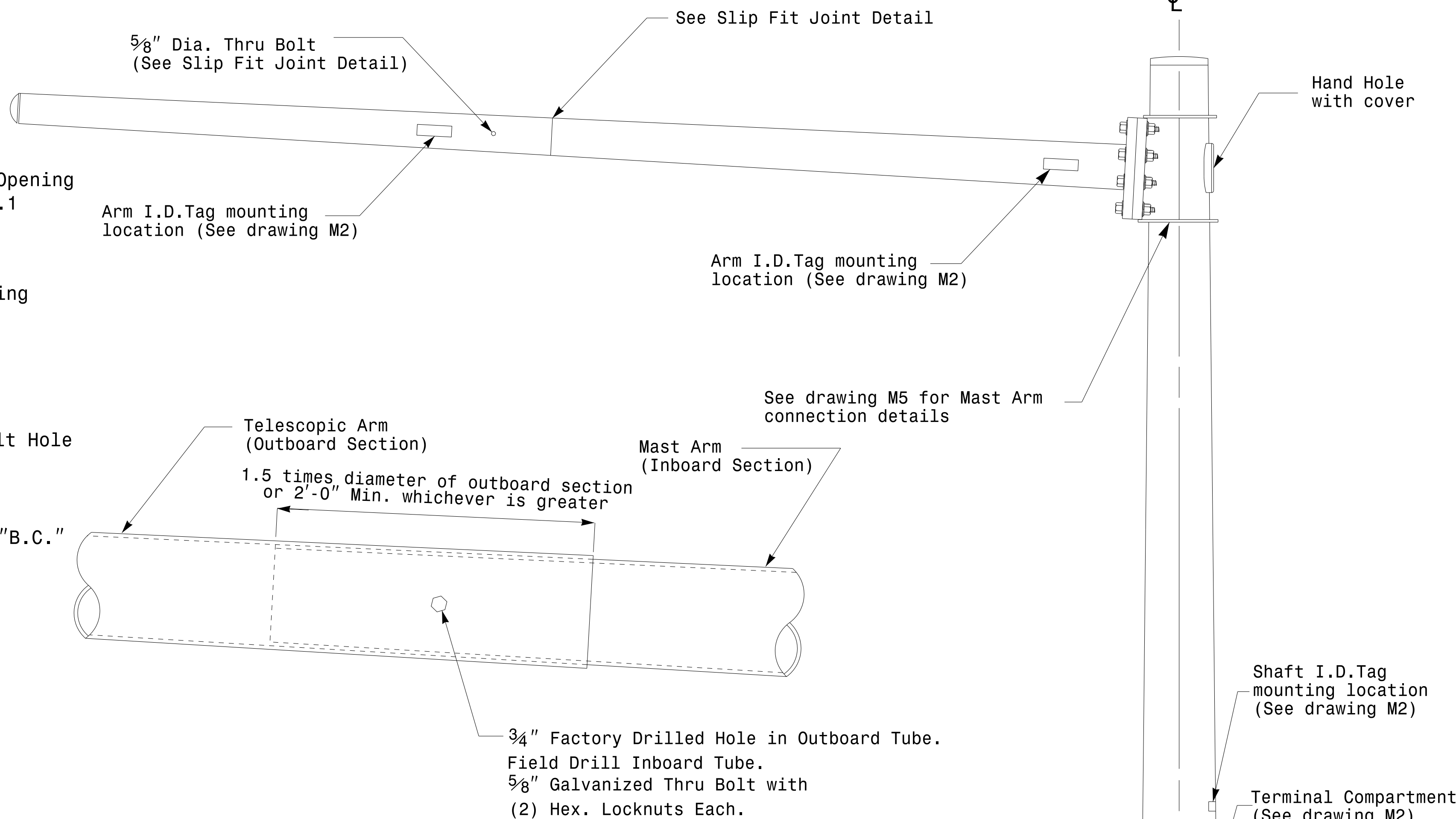

Slip Fit Joint Detail for Mast Arm

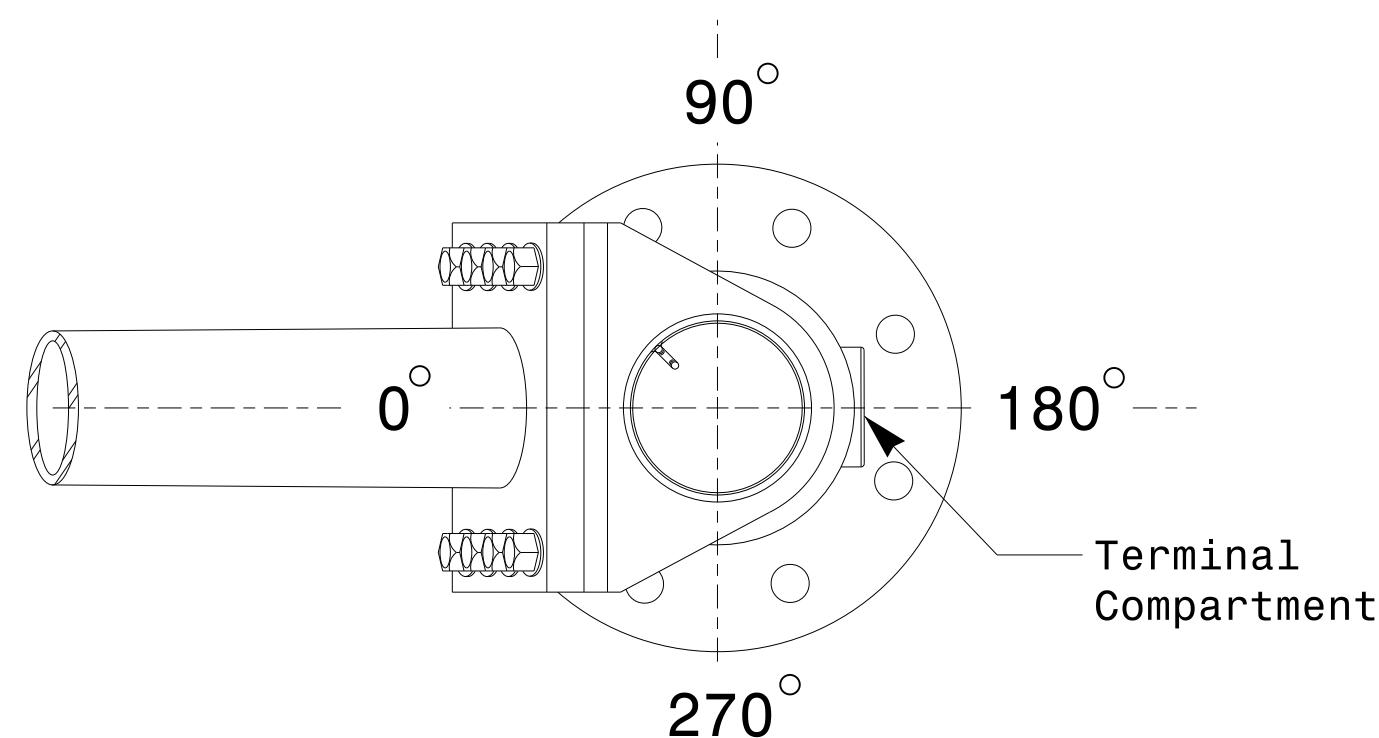

Mast Arm Radial Orientation

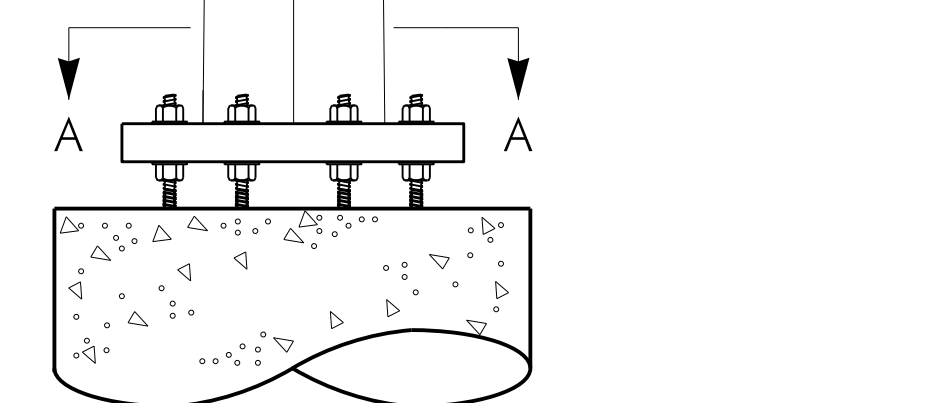

Mast Arm Pole

Fabrication Details - Mast Arm Poles

<p>Prepared in the Offices of: 750 N. Greenfield Pkwy, Garner, NC 27529</p>	Typical Fabrication Details For Mast Arm Poles		SEAL D. C. SARKAR ENGINEER
	PLAN DATE: OCTOBER 2017 PREPARED BY: N. BITTING	DESIGNED BY: K.C. DURIGON REVIEWED BY: D.C. SARKAR	
SCALE: 0 NA NONE	DocuSigned by: Dinesh C. Sarkar		10/11/2017 DATE

11-OCT-2017 08:33
C:\Users\sig\Documents\Design Section\Eastern Region\Sheet\2016\2014_Sig_M4_Std_Fabrication_Details-Mast_Arm_Poles.dgn
PLOT