

EDI MODEL 2018EClip-NC CONFLICT MONITOR

PROGRAMMING DETAIL

(remove jumpers and set switches as shown)

REMOVE DIODE JUMPERS 2-5, 2-6, 2-9, 2-11, 2-13, 2-15, 4-8, 4-16, 5-9, 5-11, 5-13, 6-9, 6-11, 6-13, 6-15, 8-16, 9-11, 9-13, 9-15, 11-13, 11-15 and 13-15.

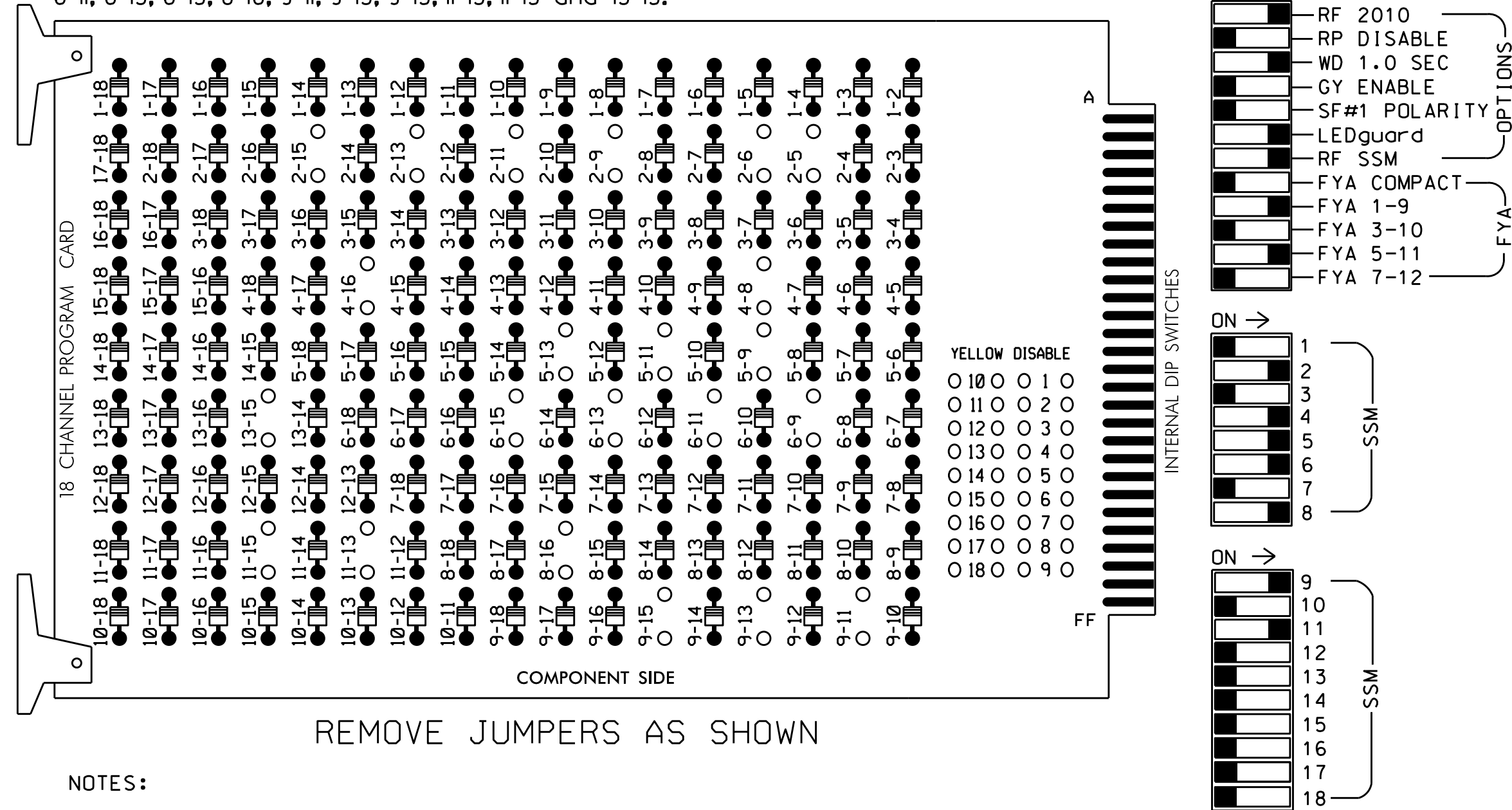

REMOVE JUMPERS AS SHOWN

NOTES:

- Card is provided with all diode jumpers in place. Removal of any jumper allows its channels to run concurrently.
- Ensure jumpers SEL2-SEL5 and SEL9 are present on the monitor board.
- Ensure that Red Enable is active at all times during normal operation.
- Ensure Conflict Monitor Ethernet port is connected to a Switch port located within the cabinet.

■ = DENOTES POSITION OF SWITCH

NOTES

- To prevent "flash-conflict" problems, insert red flash program blocks for all unused vehicle load switches in the output file. The installer shall verify that signal heads flash in accordance with the Signal Plans.
- Initialize database in Naztec 2070 local software (Apogee) as FULL-CALTRANS. This initialization should be done prior to programming controller.
- Initialize I/O "C1-C11-ABC IO Mode" to USER (MM 1-8-6). Then set "Init 2A" to MODE 5 (MM 1-8-9-3).
- Program phases 2 and 6 for Start Up In Walk.
- Program "Start Up Flash" for 0 sec. The conflict monitor will govern start-up flash time.
- Ensure "Local Flash Start" feature is set to "DRK".
- Program controller to provide a 1 second delay on the Flash Sense/Local Flash input. Use the following logic statement to provide this functionality:

```
FROM MAIN MENU->1->8->7 (I/O LOGIC)
Result Src.Fcn TimeOp Time
1208 = 01208 DLY 1
```
- Program phases 4 and 8 for Dual Entry.
- The cabinet and controller are part of the City of Greensboro Signal System.

EQUIPMENT INFORMATION

CONTROLLER.....2070
 CABINET.....332 W/ AUX
 SOFTWARE.....NAZTEC APOGEE
 CABINET MOUNT.....BASE
 OUTPUT FILE POSITIONS...18 (12-STD, 6-AUX)
 LOAD SWITCHES USED.....S2,S3,S5,S7,S8,S9,S11,S12, AUX S1,AUX S4
 PHASES USED.....2,2 PED,4,5,6,6 PED,8,8 PED
 OVERLAP A.....*
 OVERLAP B.....NOT USED
 OVERLAP C.....NOT USED
 OVERLAP D.....NOT USED
 * See Overlap Programming Detail Sheet 2.

SIGNAL HEAD HOOK-UP CHART

LOAD SWITCH NO.	S1	S2	S3	S4	S5	S6	S7	S8	S9	S10	S11	S12	AUX S1	AUX S2	AUX S3	AUX S4	AUX S5	AUX S6
CMU CHANNEL NO.	1	2	13	3	4	14	5	6	15	7	8	16	9	10	17	11	12	18
PHASE	1	2	2 PED	3	4	4 PED	5	6	6 PED	7	8	8 PED	OLA	OLB	SPARE	OLC	OLD	SPARE
SIGNAL HEAD NO.	NU	21,22	P21, P22	NU	41,42	NU	42	51	62,63	P61, P62	NU	81,82	P81, P82	61	NU	NU	51	NU
RED		128			101		*		134			107						
YELLOW		129			102				135			108						
GREEN		130			103				136			109						
RED ARROW														A121				A114
YELLOW ARROW									132					A122				A115
FLASHING YELLOW ARROW														A123				A116
GREEN ARROW								133	133									
Hand				113						119					110			
Person				115						121					112			

NU = Not Used

* Denotes install load resistor. See load resistor installation detail this sheet.

★ See pictorial of head wiring in detail below.

FYA SIGNAL WIRING DETAIL

(wire signal heads as shown)

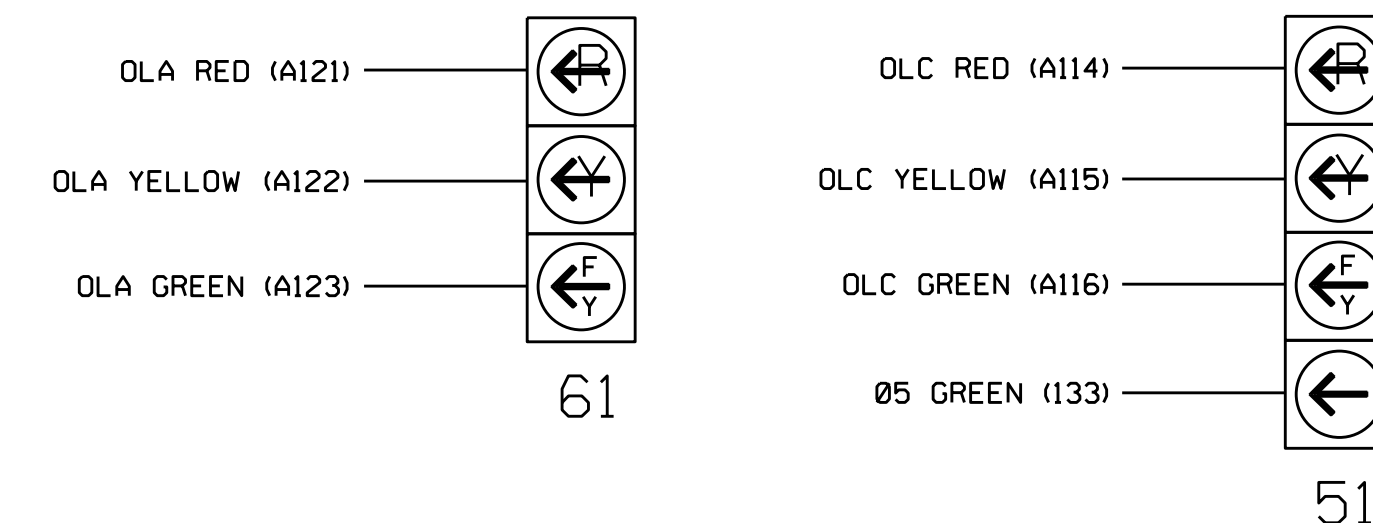

INPUT FILE POSITION LAYOUT

(from view)

FILE	U	1	2	3	4	5	6	7	8	9	10	11	12	13	14
FILE "I"	U	∅S	∅2	∅S	∅S	∅S	∅4	∅S	∅S	∅S	∅S	∅S	∅2 PED	∅6 PED	FS
		←-→	2A	←-→	←-→	←-→	4A	←-→	←-→	←-→	←-→	←-→	DC ISOLATOR	DC ISOLATOR	DC ISOLATOR
		←-→	2B	←-→	←-→	←-→	∅5	←-→	←-→	←-→	←-→	←-→	NOT USED	∅8 PED	ST
FILE "J"	U	∅5	∅6	∅6	∅S	∅S	∅8	∅S	∅S	∅S	∅S	∅S	∅S	∅S	∅S
		←-→	5A	←-→	←-→	←-→	8A	←-→	←-→	←-→	←-→	←-→	←-→	←-→	←-→
		←-→	6A	←-→	←-→	←-→	∅8	←-→	←-→	←-→	←-→	←-→	←-→	←-→	←-→
FILE "L"	U	NOT USED	∅6	NOT USED	∅S	∅S	∅8	∅S	∅S	∅S	∅S	∅S	∅S	∅S	∅S
		←-→	6B	←-→	←-→	←-→	8B	←-→	←-→	←-→	←-→	←-→	←-→	←-→	←-→

EX.: 1A, 2A, ETC. = LOOP NO.'S

FS = FLASH SENSE
 ST = STOP TIME

INPUT FILE CONNECTION & PROGRAMMING CHART

LOOP NO.	LOOP TERMINAL	INPUT FILE POS.	PIN NO.	DETECTOR NO.	CALL PHASE	SWITCH	DELAY TIME	EXTEND TIME	CALL	EXTEND	ADDED INIT.
2A	TB2-5,6	I2U	39	2	2				X	X	X
2B	TB2-7,8	I2L	43	3	2				X	X	X
4A	TB4-9,10	I6U	41	8	4				X	X	
5A	TB3-1,2	J1U	55	15	5		15		X	X	
5B	TB4-11,12	I6L	45	9	5		15		X	X	
6A	TB3-5,6	J2U	40	16	6				X	X	X
6B	TB3-7,8	J2L	44	17	6				X	X	X
6C	TB3-9,10	J3U	64	18	6				X	X	
8A	TB5-9,10	J6U	42	22	8				X	X	
8B	TB5-11,12	J6L	46	23	8		10		X	X	
PED PUSH BUTTONS											
P21,P22	TB8-4,6	I12U	67	PED 2	2 PED						
P61,P62	TB8-7,9	I13U	68	PED 6	6 PED						
P81,P82	TB8-8,9	I13L	70	PED 8	8 PED						

NOTE:
 INSTALL DC ISOLATORS
 IN INPUT FILE SLOT 113.

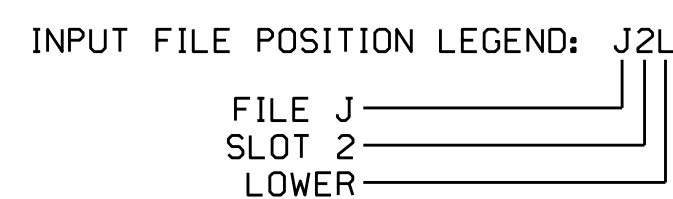

LOAD RESISTOR INSTALLATION DETAIL

(install resistor as shown below)

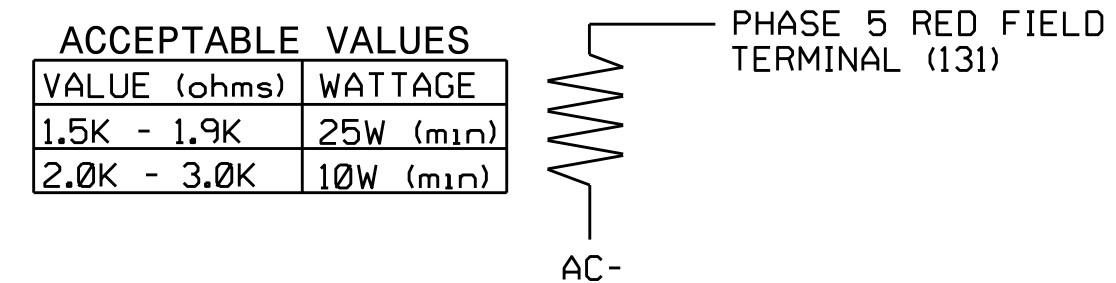

COUNTDOWN PEDESTRIAN SIGNAL OPERATION

Countdown Ped Signals are required to display timing only during Ped Clearance Interval. Consult Ped Signal Module user's manual for instructions on selecting this feature.

THIS ELECTRICAL DETAIL IS FOR
 THE SIGNAL DESIGN: GBO-559T3
 DESIGNED: October 2017
 SEALED: 10/31/2017
 REVISED:

Electrical Detail - Temp 3 - Sheet 1 of 3

Prepared In the Offices of:
 GULFORD COUNTY DEPARTMENT OF TRANSPORTATION & SIGNALS MANAGEMENT

750 N. Greenfield Pkwy, Garner, NC 27529

DETAILS FOR: N. Elm Street at United Health Care and Lake Jeanette Office Park

Division 7 Guilford County Greensboro

PLAN DATE: October 2017 REVIEWED BY: T. Joyce

PREPARED BY: C. Strickland REVIEWED BY:

REVISIONS: INIT. DATE

DocuSign by: D. Todd Joyce 11/2/2017

SEAL: SEAL 031001

DOCUMENT NOT CONSIDERED FINAL UNLESS ALL SIGNATURES COMPLETED

SIG. INVENTORY NO. GBO-559T3

09-1004-2017_09-18
 C:\NITS\AS\NITS\Sig\Signal\work\hgr\oups\51g_Maps\Strickland\hgr\oups\559_sml.e_l_xxx.dgn
 C:\NITS\AS\NITS\Sig\Signal\work\hgr\oups\51g_Maps\Strickland\hgr\oups\559_sml.e_l_xxx.dgn