

PHASING DIAGRAM

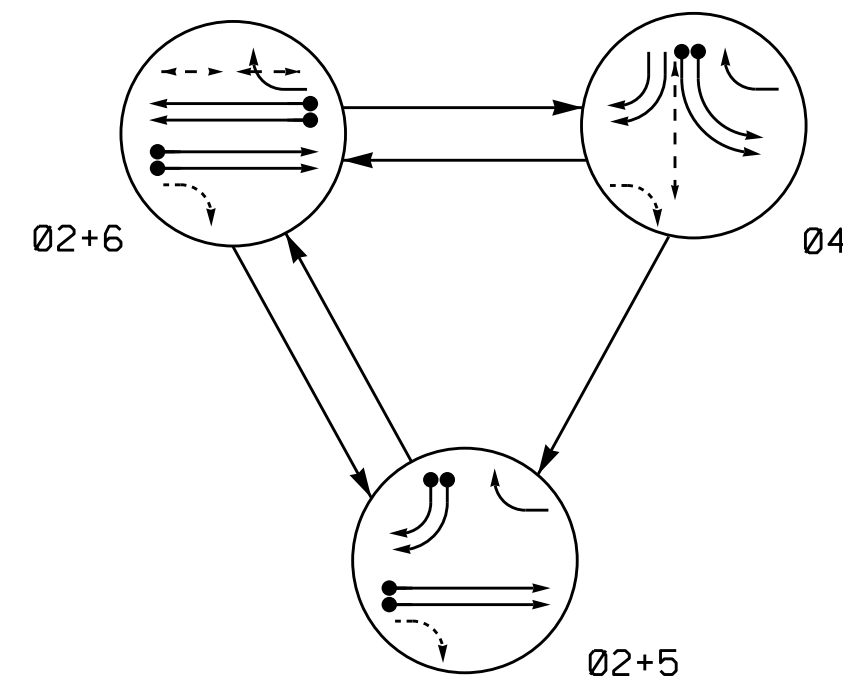

SIGNAL FACE	PHASE			
	02+6	04	04	F L S H
21, 22	G	G	R	Y
41, 42	R	R	L	R
51, 52, 53	-	R	-	R
61	R	G	R	Y
62	R	G	R	Y
P41, P42	DW	DW	W	DRK
P61, P62	DW	W	DW	DRK
P63, P64	DW	W	DW	DRK

W - Walk
DW - Don't Walk
DRK - Dark

LOOP & DETECTOR UNIT INSTALLATION CHART												
NAZTEC APOGEE SOFTWARE 2070 CONTROLLER												
INDUCTIVE LOOPS					DETECTOR PROGRAMMING							
LOOP	SIZE (FT)	DISTANCE FROM STOPBAR (FT)	TURNS	NEW LOOP	PHASE	SWITCH (PHASE)	DELAY TIME	STRETCH TIME	CALLING	EXTENSION	ADDED INIT.	SYSTEM LOOP NEW CARD
2A	6X6	250	5	X	2	-	-	-	X	X	X	-
2B	6X6	250	5	X	2	-	-	-	X	X	X	-
4A	6X40	0	2-4-2	X	4	-	-	-	X	X	-	-
4B	6X40	0	2-4-2	X	4	-	-	-	X	X	-	-
5A	6X40	0	2-4-2	X	5	-	15	-	X	X	-	-
5B	6X40	0	2-4-2	X	5	-	15	-	X	X	-	-
6A	6X6	250	5	X	6	-	-	-	X	X	X	-
6B	6X6	250	5	X	6	-	-	-	X	X	X	-

3 Phase Fully Actuated (Greensboro Signal System)

NOTES

- Refer to "Roadway Standard Drawings NCDOT" dated January 2018 and "Standard Specifications for Roads and Structures" dated January 2018.
- Do not program signal for late night flashing operation unless otherwise directed by the Engineer.
- Phase 5 may be lagged.
- Set all detector units to presence mode.
- Locate new cabinet so as not to obstruct sight distance of vehicles turning right on red.
- Omit "WALK" and flashing "DON'T WALK" with no pedestrian calls.
- Program pedestrian heads to countdown the flashing "Don't Walk" time only.
- Pedestrian pedestals are conceptual and shown for reference only. See sheets P1-P3 for pushbutton location details.
- Maximum times shown in timing chart are for free-run operation only. Coordinated signal system timing values supersede these values.

PHASING DIAGRAM DETECTION LEGEND

- DETECTED MOVEMENT
- UNDETECTED MOVEMENT (OVERLAP)
- UNSIGNALIZED MOVEMENT
- PEDESTRIAN MOVEMENT

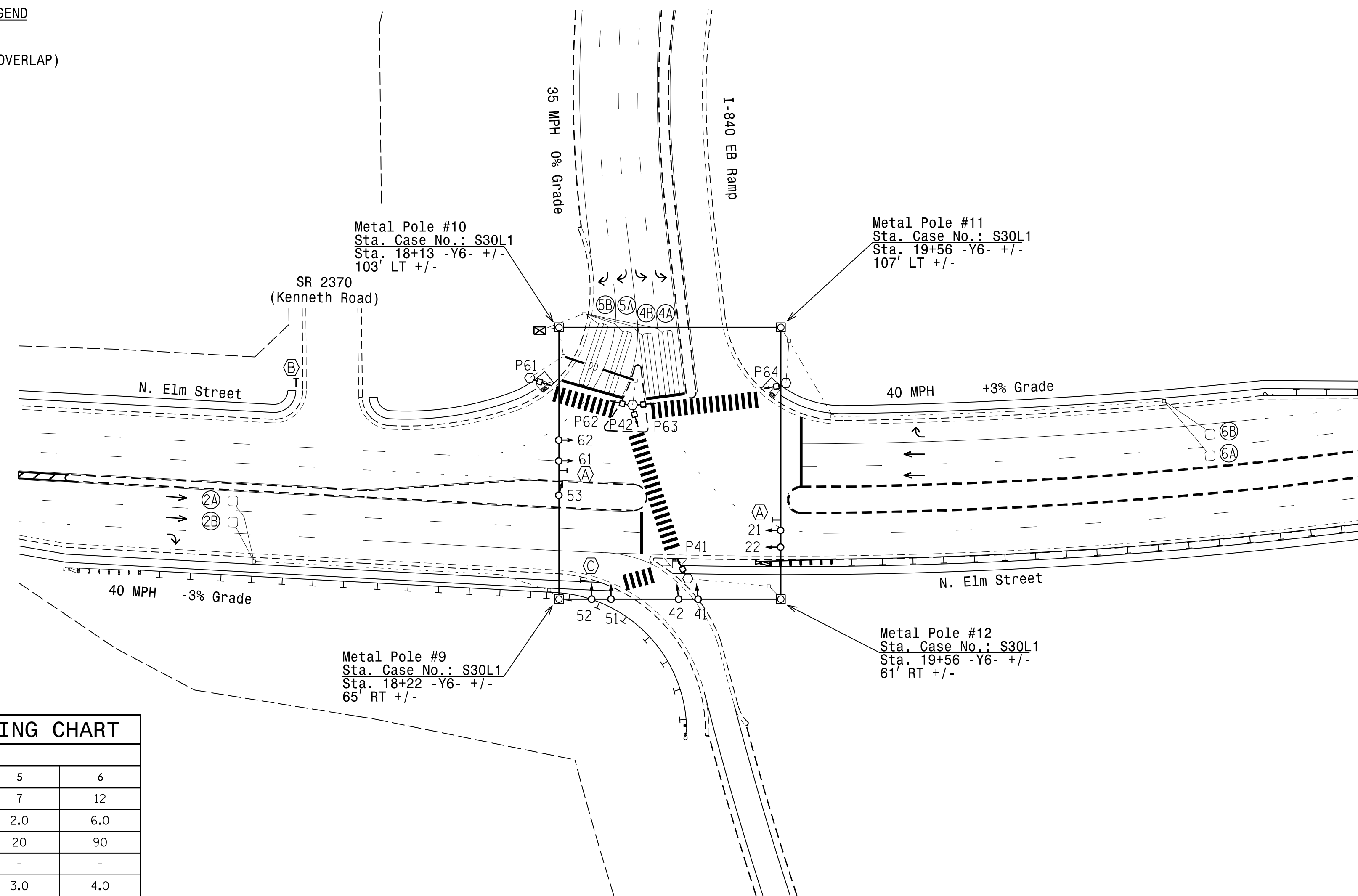

FEATURE	PHASE			
	2	4	5	6
Min Green *	12	7	7	12
Gap, Extension *	6.0	2.0	2.0	6.0
Maximum Green 1 *	90	30	20	90
Maximum Green 2 *	-	-	-	-
Yellow Clear	4.4	3.0	3.0	4.0
Red Clear	1.6	3.7	1.9	2.8
Walk *	-	7	-	7
Pedestrian Clear	-	20	-	19
Added Initial *	2.0	-	-	2.0
Maximum Initial *	29	-	-	29
Time Before Reduction *	15	-	-	15
Time To Reduce *	30	-	-	30
Minimum Gap	3.0	-	-	3.0
Recall Mode	MIN RECALL	-	-	MIN RECALL
Lock Calls	YES	NO	NO	YES
Dual Entry	-	-	-	-
Simultaneous Gap	ON	ON	ON	ON

* These values may be field adjusted. Do not adjust Min Green and Extension times for phases 2 and 6 lower than what is shown. Min Green for all other phases should not be lower than 4 seconds.

PROPOSED	EXISTING
Traffic Signal Head	N/A
Modified Signal Head Sign	N/A
Pedestrian Signal Head With Push Button & Sign	N/A
Signal Pole with Guy	N/A
Signal Pole with Sidewalk Guy	N/A
Inductive Loop Detector	N/A
Controller & Cabinet	N/A
Junction Box	N/A
2-in Underground Conduit	N/A
Right of Way	N/A
Directional Arrow	N/A
Guardrail	N/A
Curb Ramp	N/A
Type II Signal Pedestal	N/A
Directional Drill	N/A
Metal Strain Pole	N/A
(A) No U-Turn/No Left Turn Sign (R3-18)	(A)
(B) "STOP" Sign (R1-1)	(B)
(C) Pedestrian Crossing Sign (W11-2)	(C)

SIGNAL FACE I.D.

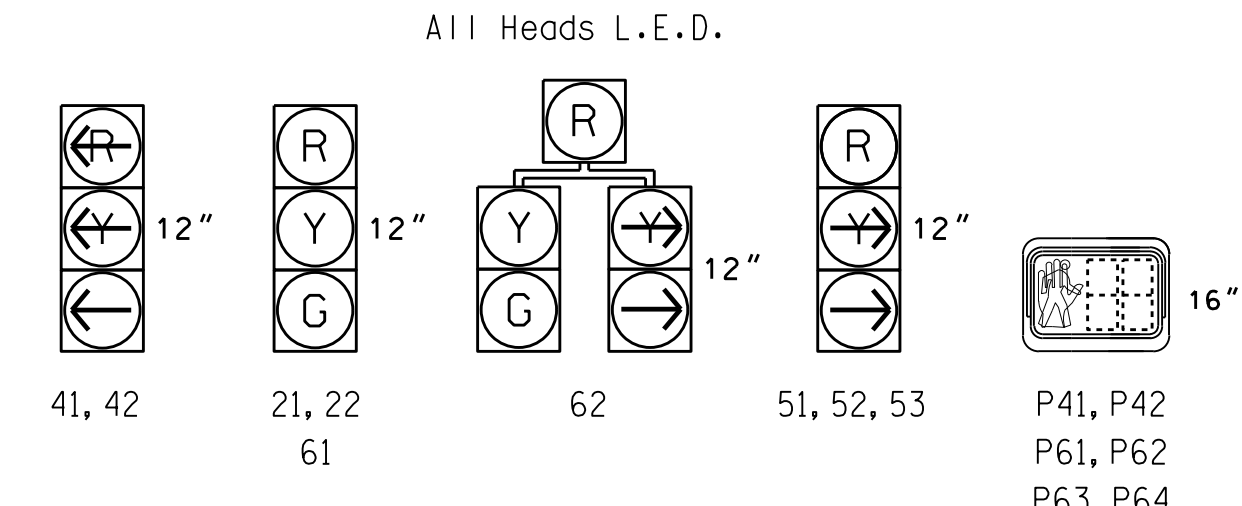

New Installation

750 N. Greenfield Pkwy, Garner, NC 27529

Prepared in the Offices of:

 TRANSPORTATION MOBILITY AND SAFETY DIVISION
 DEPARTMENT OF TRANSPORTATION
 SIGNAL DESIGN SECTION

N. Elm Street at I-840 EB Ramps

Division 7 Guilford County Greensboro

PLAN DATE: September 2017 REVIEWED BY:

PREPARED BY: I. O. Umzurike REVIEWED BY:

REVISIONS: INIT. DATE

SCALE: 1"=50'

DOCUMENT NOT CONSIDERED FINAL UNLESS ALL SIGNATURES COMPLETED

SEAL: ROBERT J. ZIEMBA, ENGINEER, No. 026486

DATE: 10/24/2017

SIG. INVENTORY NO. 07-1721

24-001-2017, 12-31, R:\Traffic\cans\signal\shd\as\gn\45\gn\01\121-121\4071721-121\sig_dsn\20171024.dgn, rzl,emba