

TIP NO. U-2525C	SHEET NO. PMP-25
Approved by: <i>Andrew D. Klinck</i> <small>E3078F8498E44B</small> DATE: 12/11/2017	
	
DOCUMENT NOT CONSIDERED FINAL UNLESS ALL SIGNATURES COMPLETED	

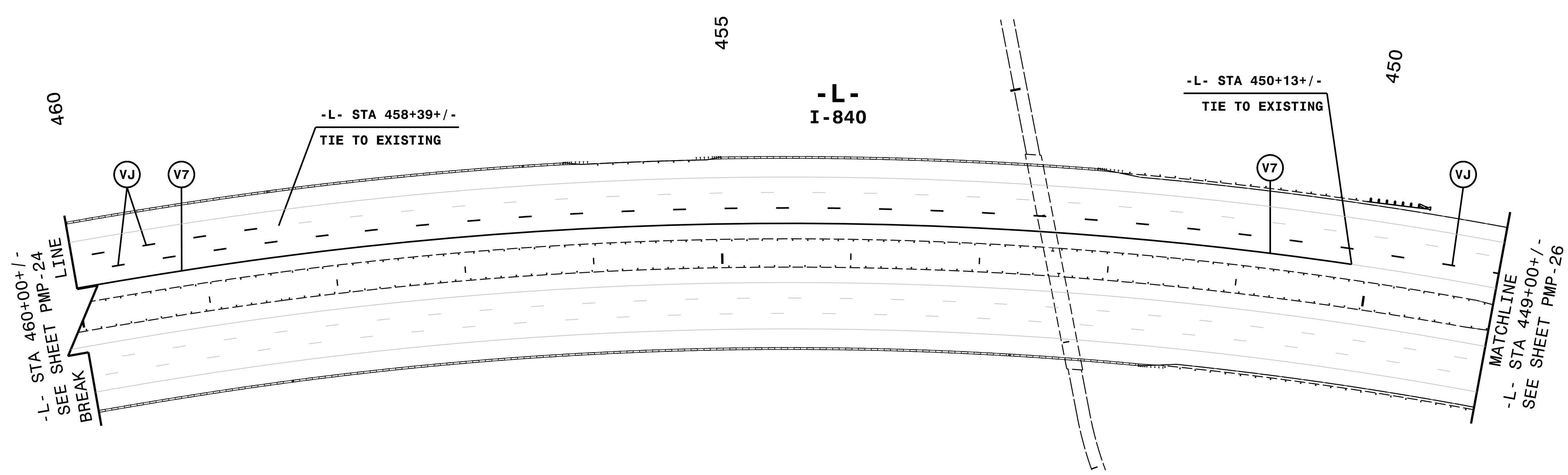

NOTE: ALL LANE WIDTHS ARE 12' UNLESS OTHERWISE SHOWN.

REMOVE CONFLICTING PAVEMENT MARKING.

IV/7/2017
 I:\PMP\ustrn\U2525C_PMP_25.dgn
 HNTB

HNTB HNTB NORTH CAROLINA, P.C.
 343 E. SIX FORKS ROAD, SUITE 200
 RALEIGH, NORTH CAROLINA 27609
 NC LICENSE NO: C-1554
 (919) 546-8997

PAVEMENT MARKING DETAIL