

TIP NO. U-2525C	SHEET NO. PMP-4
APPROVED: <i>Andrew D. Klincksiek</i> <small>E3078FB498E44B</small>	
DATE: 12/11/2017	
	
DOCUMENT NOT CONSIDERED FINAL UNLESS ALL SIGNATURES COMPLETED	

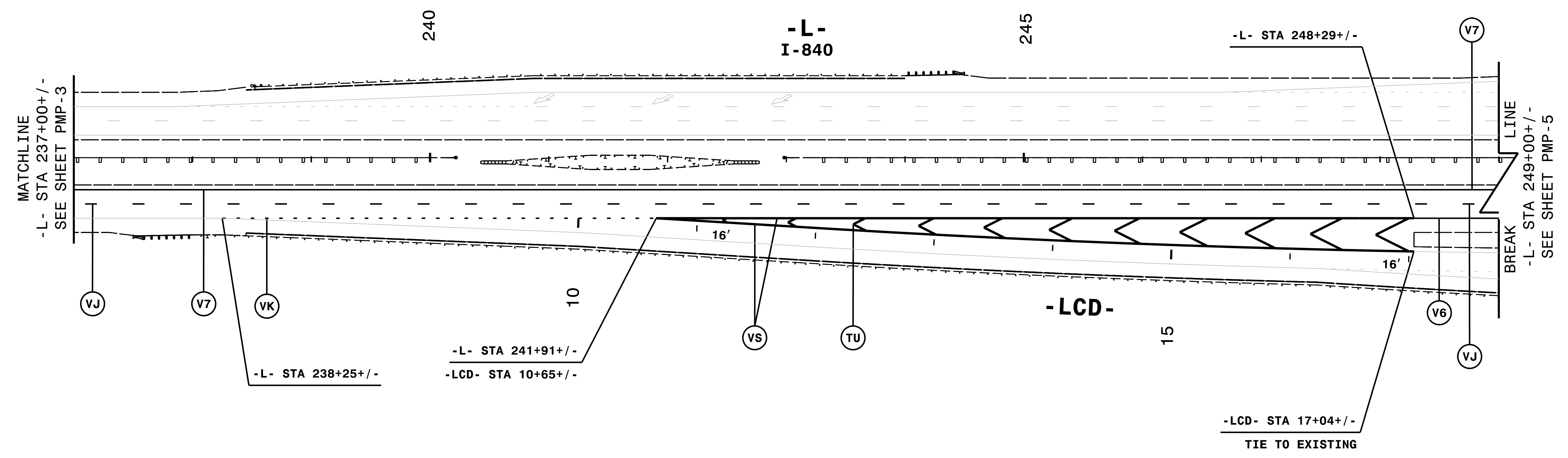

NOTE: ALL LANE WIDTHS ARE 12' UNLESS OTHERWISE SHOWN.
REMOVE CONFLICTING PAVEMENT MARKING.

11/7/2017
I:\PMP\ustr\U2525C_PMP_04.dgn
HNTB

HNTB
HNTB NORTH CAROLINA, P.C.
 343 E. SIX FORKS ROAD, SUITE 200
 RALEIGH, NORTH CAROLINA 27609
 NC LICENSE NO: C-1554
 (919) 546-8997

PAVEMENT MARKING DETAIL