

TIP NO. U-2525C	SHEET NO. PMP-3
APPROVED: <i>Andrew D. Klincksiek</i> <small>E3078FB498E44B</small>	
DATE: 12/11/2017	
	
DOCUMENT NOT CONSIDERED FINAL UNLESS ALL SIGNATURES COMPLETED	

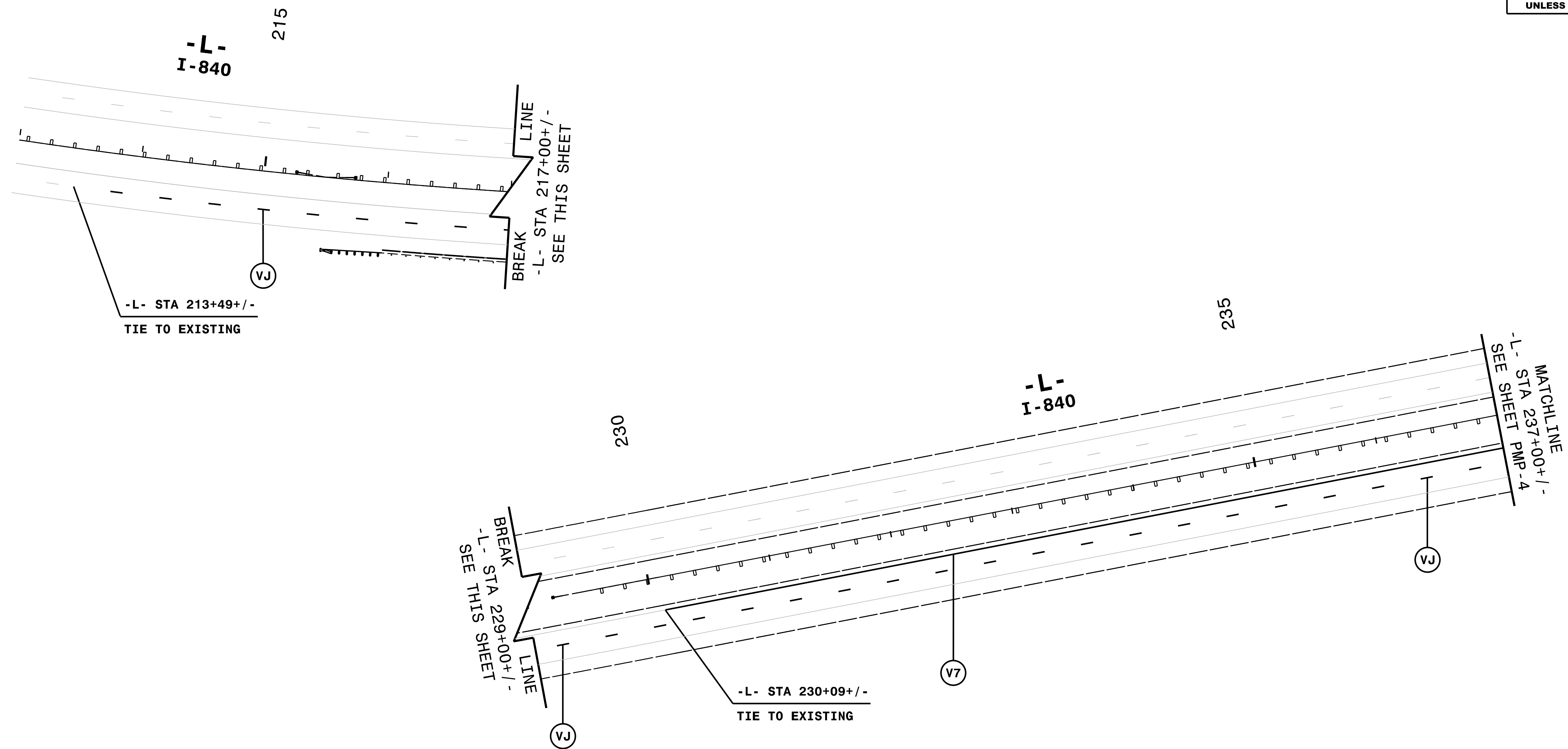
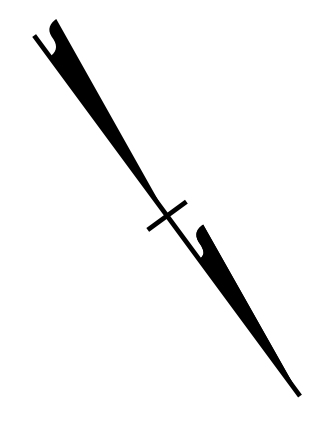

NOTE: ALL LANE WIDTHS ARE 12' UNLESS OTHERWISE SHOWN.

REMOVE CONFLICTING PAVEMENT MARKING.

IV/7/2017  
I:\PMP\ustrn\U2525C\_PMP\_03.dgn  
HNTB

**HNTB**  
 HNTB NORTH CAROLINA, P.C.  
 343 E. Six Forks Road, Suite 200  
 Raleigh, North Carolina 27609  
 NC License No: C-1554  
 (919) 546-8997

# PAVEMENT MARKING DETAIL