

8.17.799

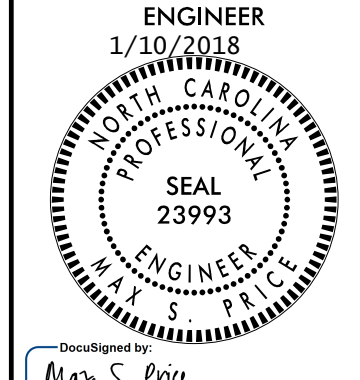

DOCUMENT NOT CONSIDERED FINAL UNLESS ALL SIGNATURES COMPLETED

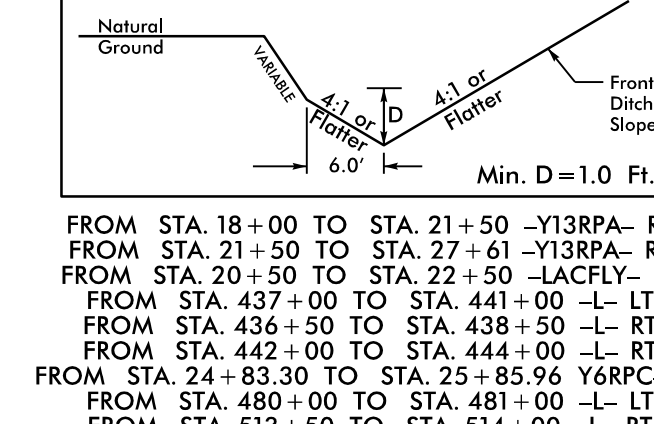
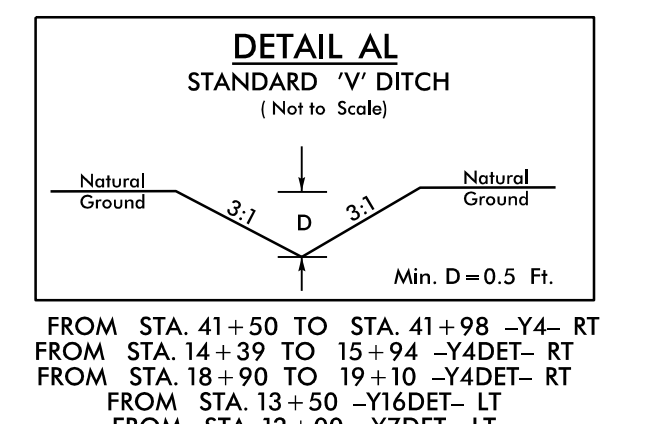
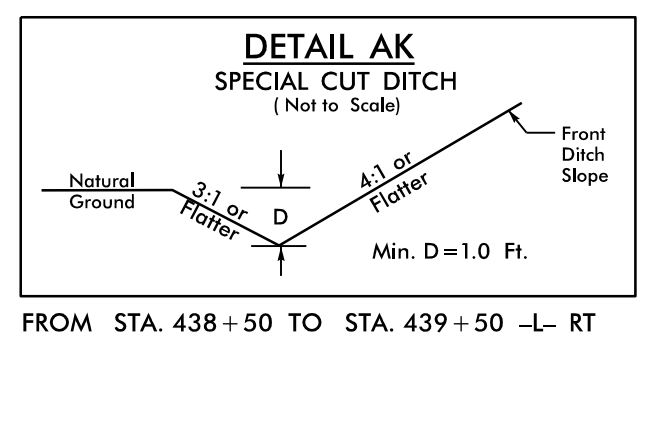
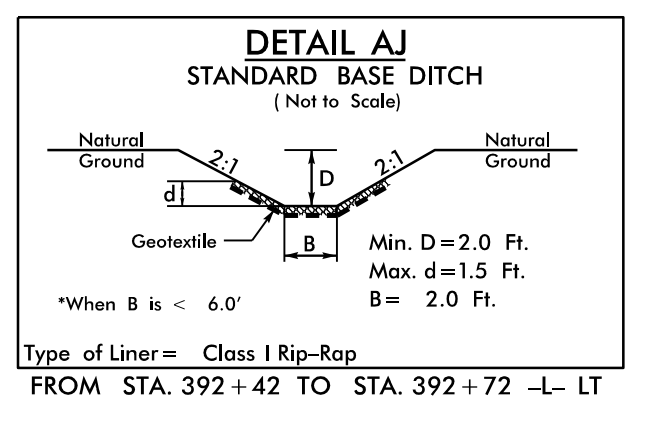
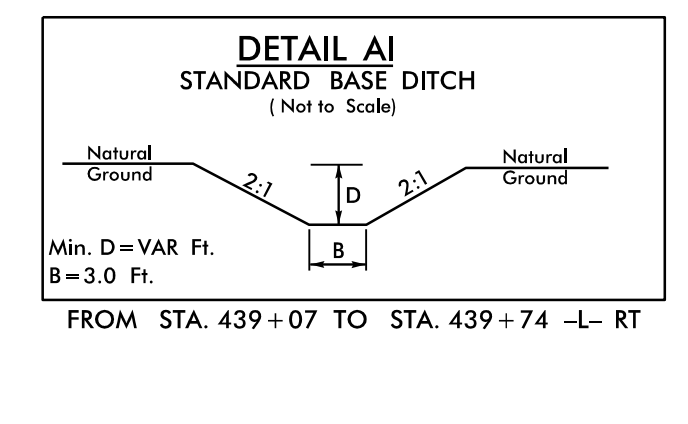
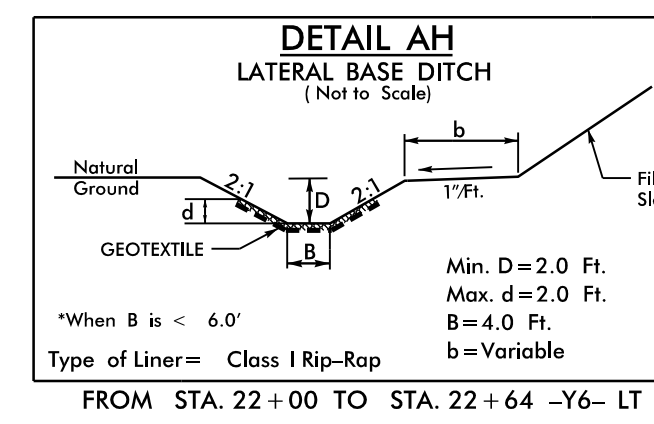
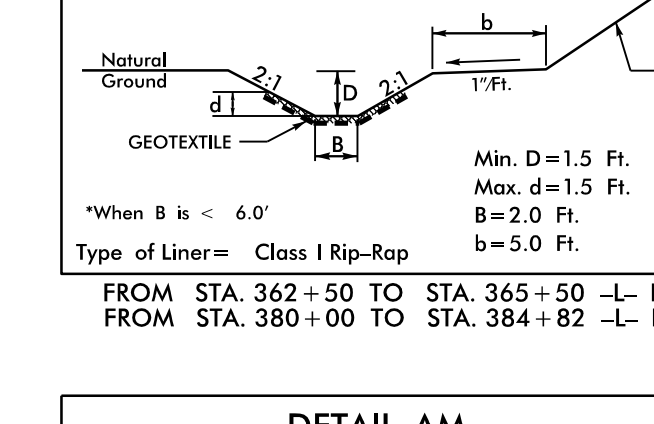
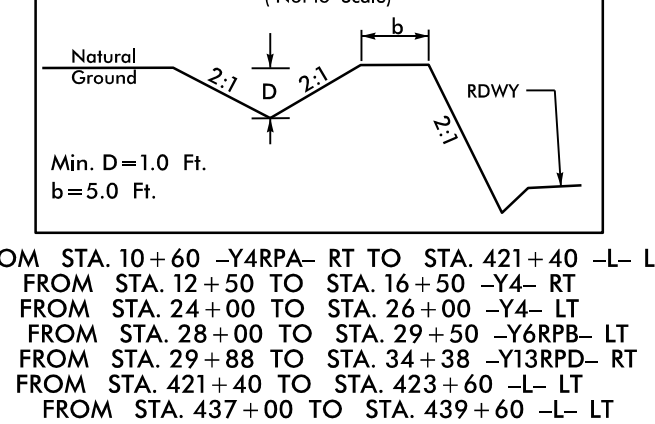
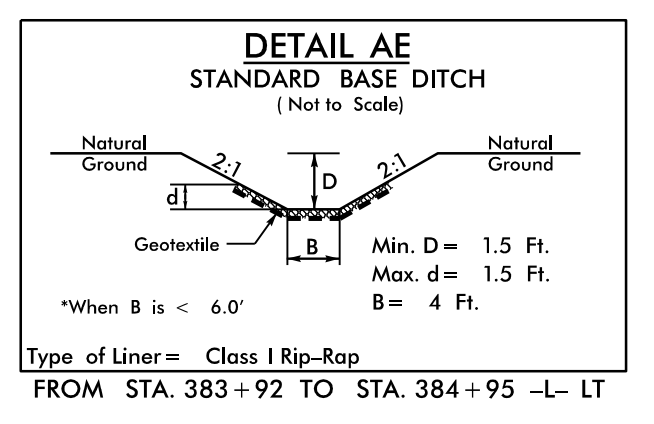
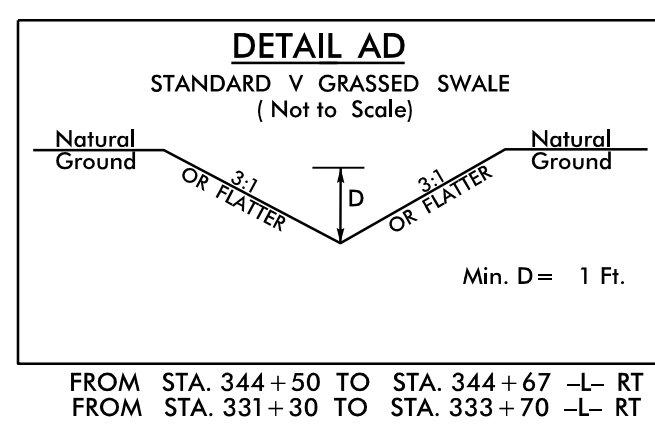
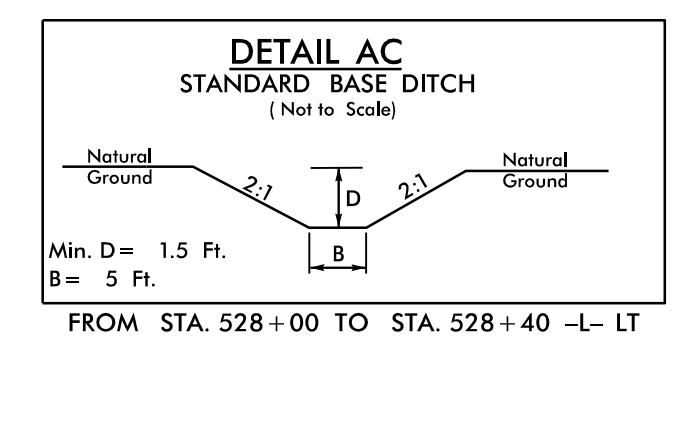
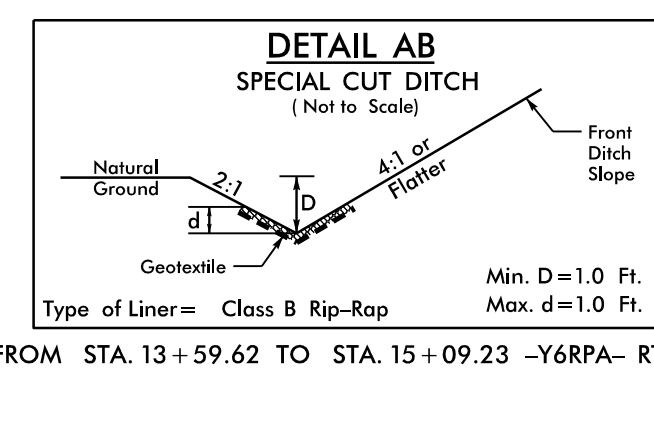
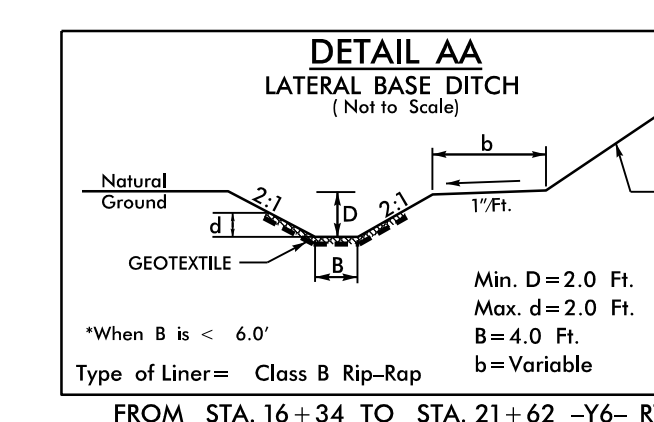
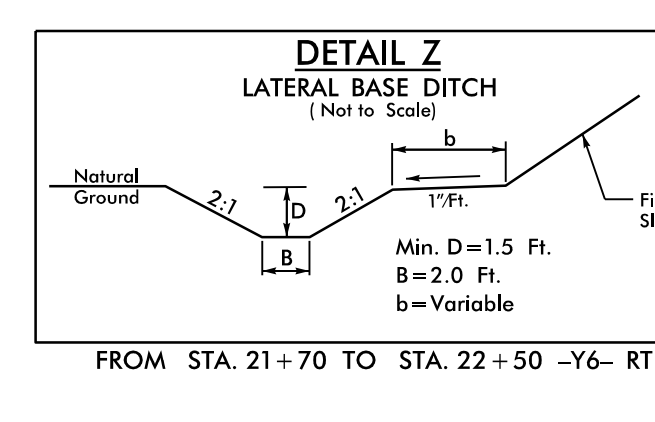
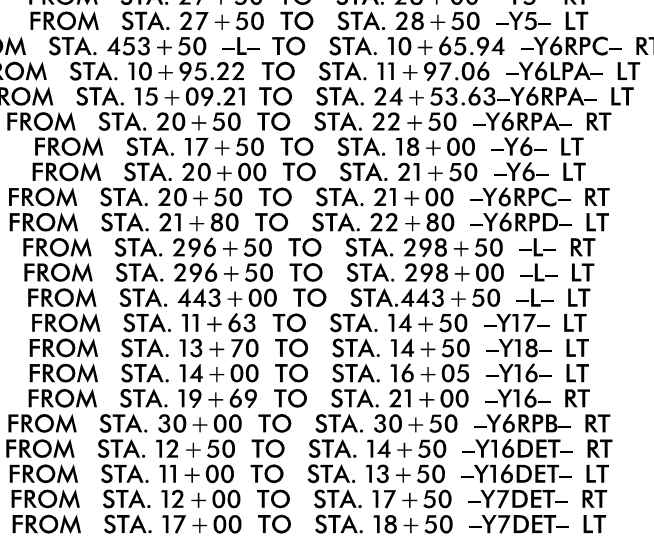
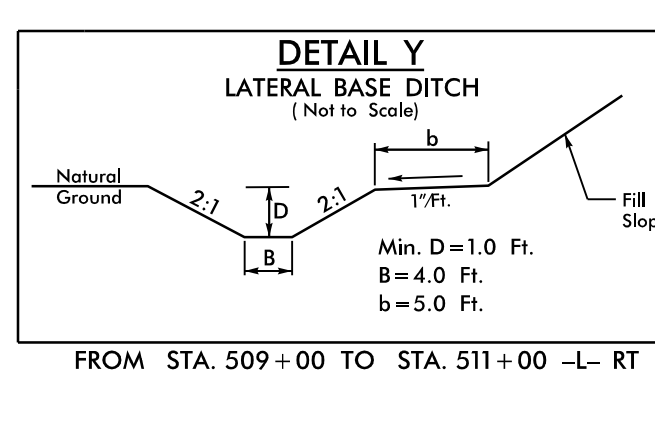
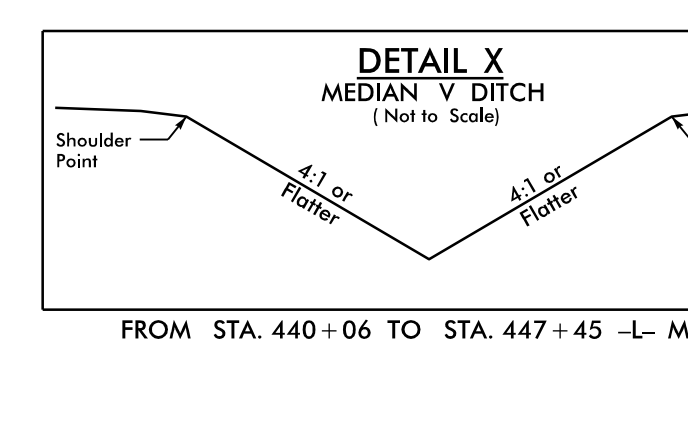
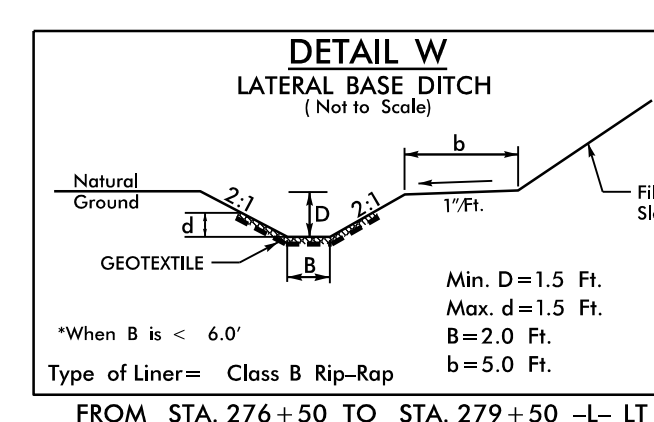
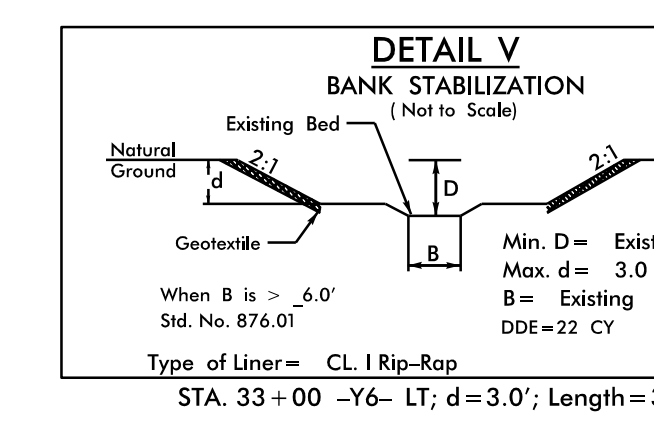
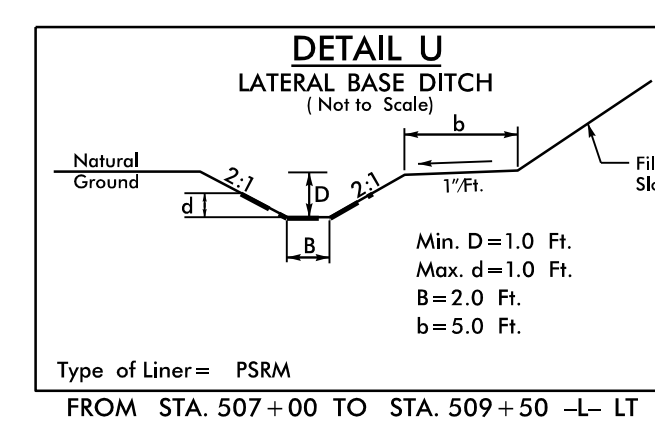
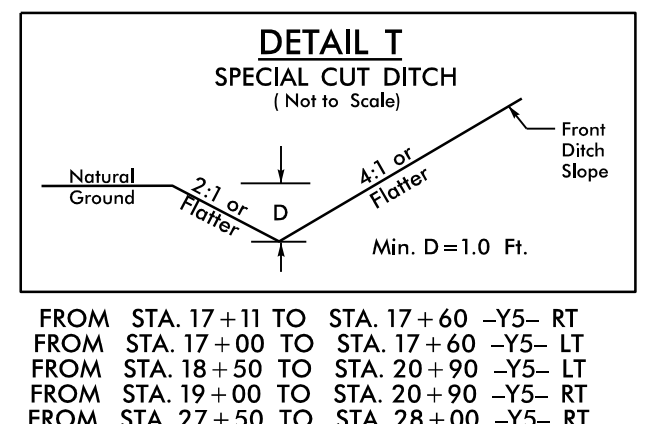
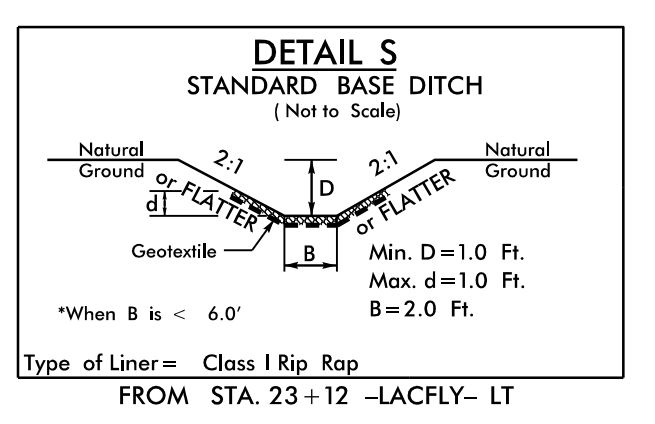
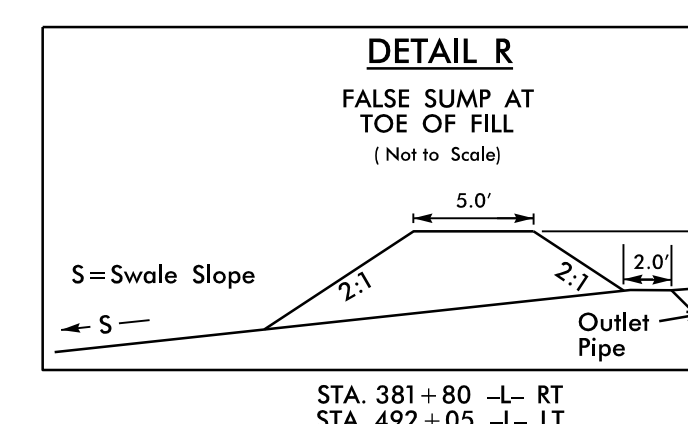
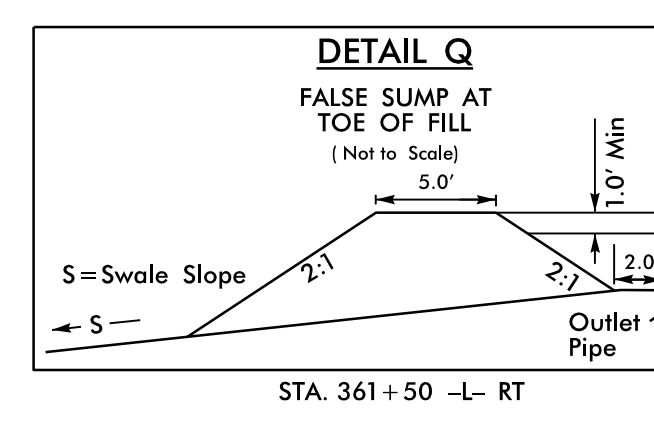
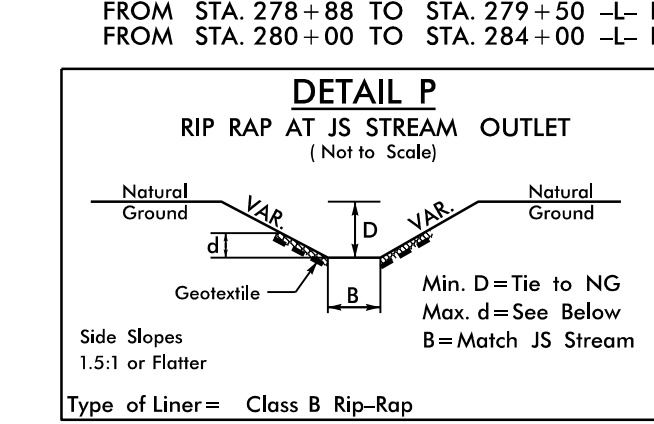
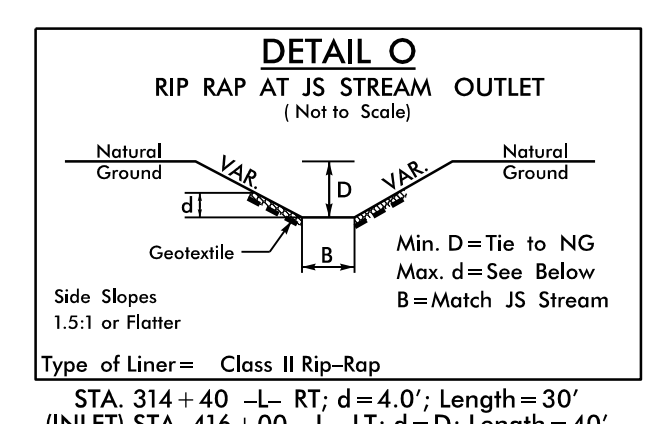
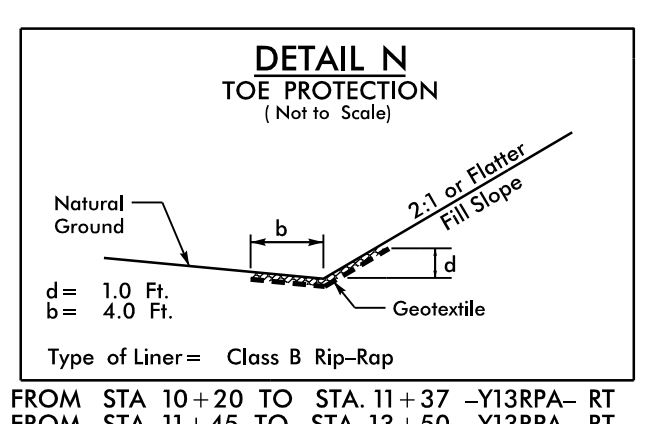
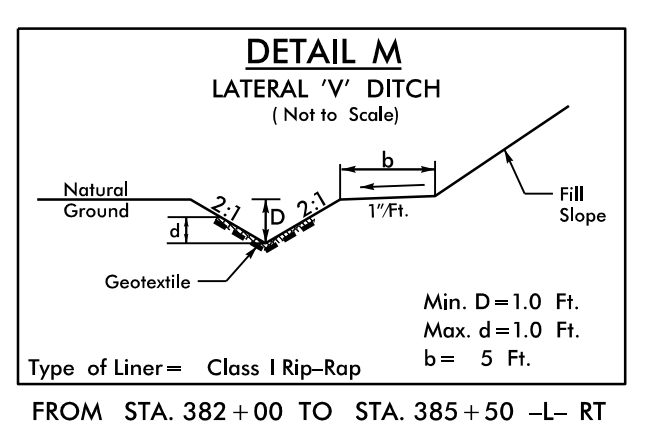
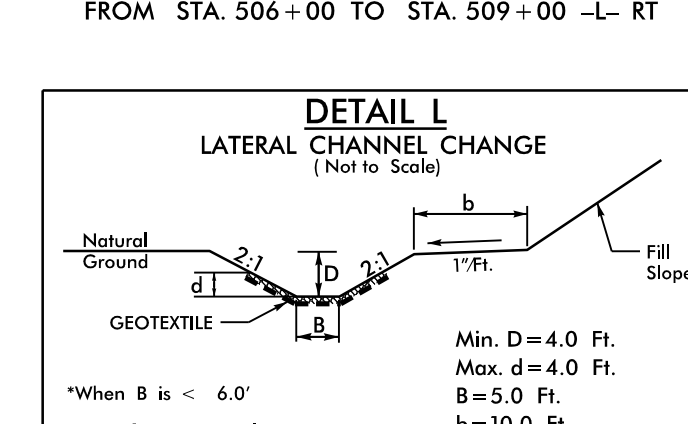
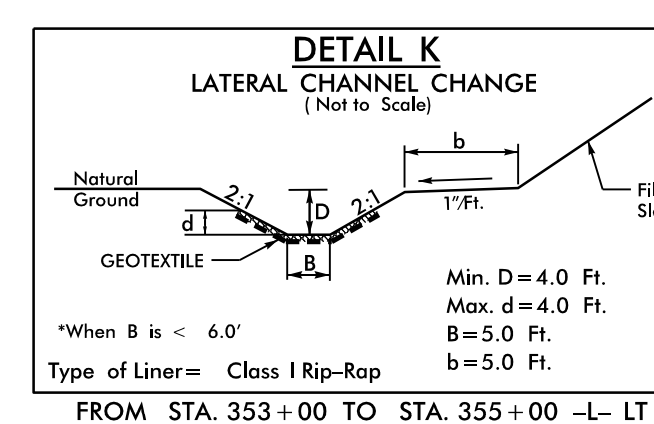
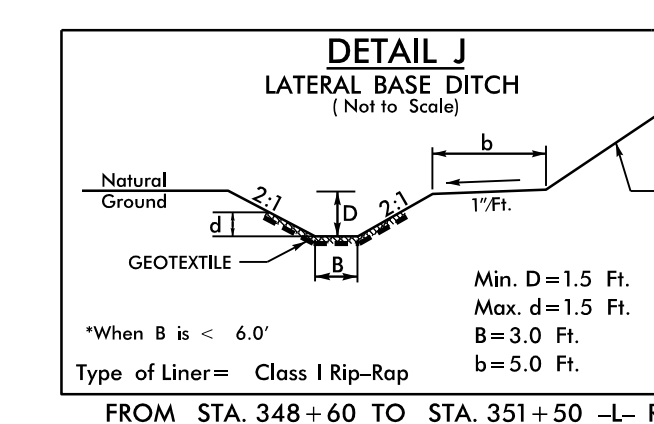
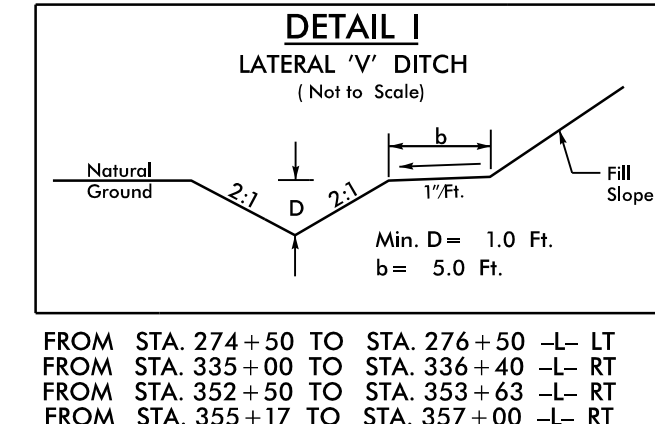
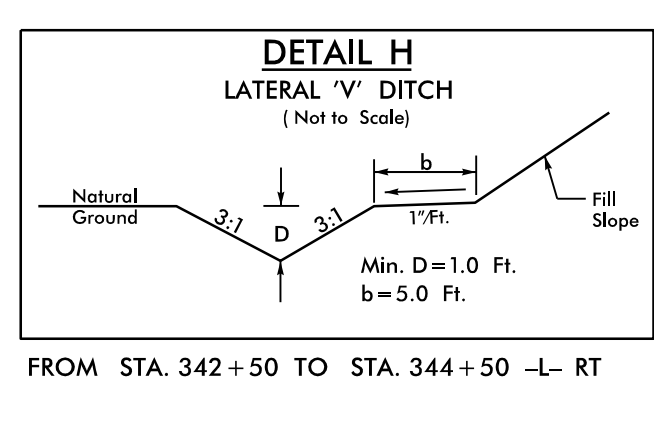
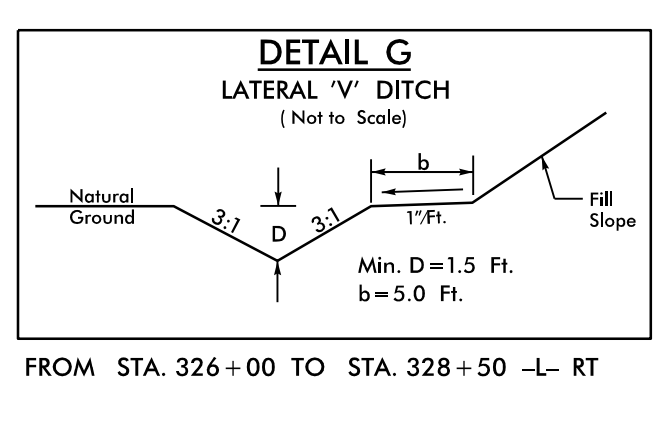
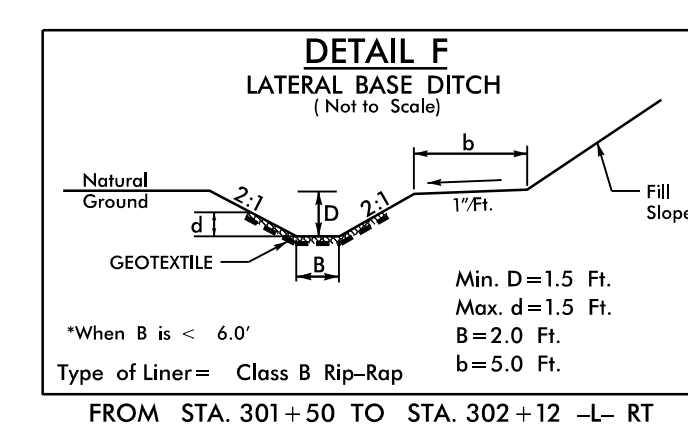
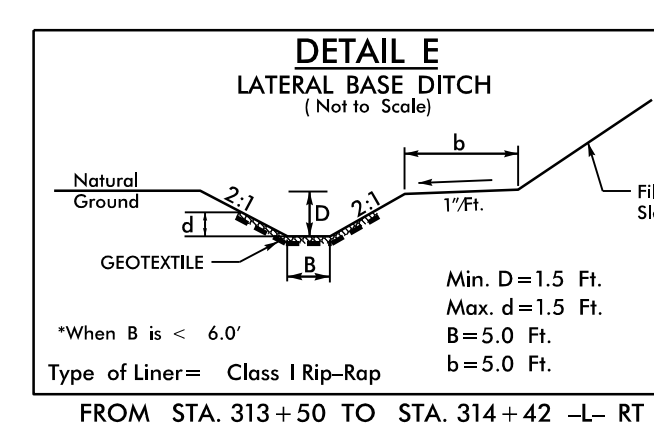
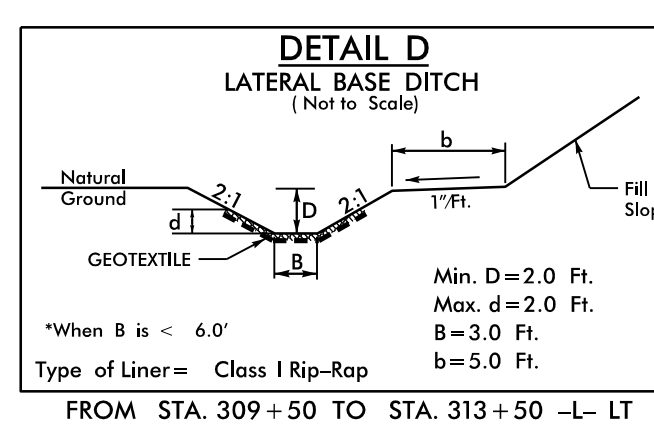
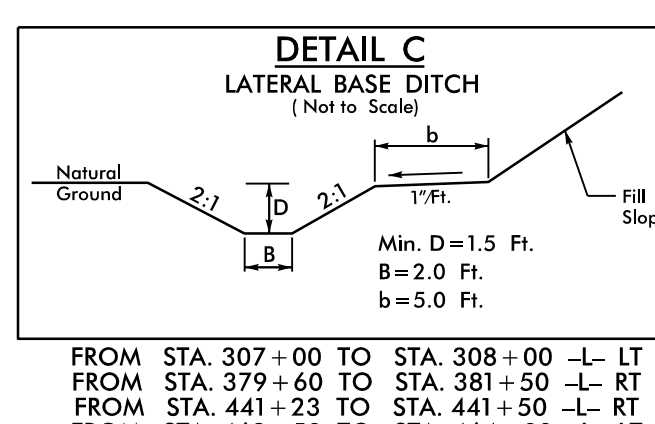
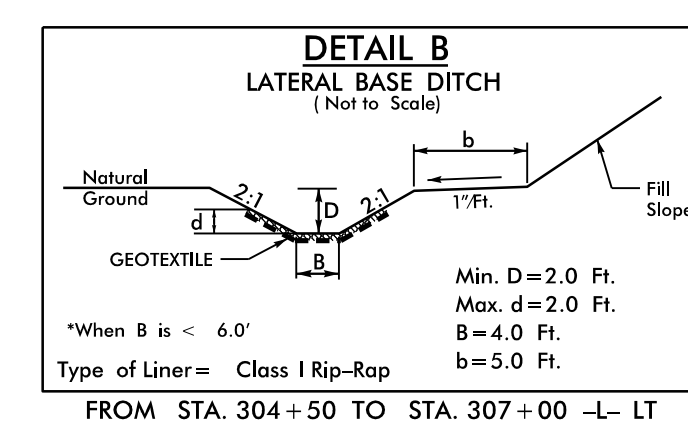
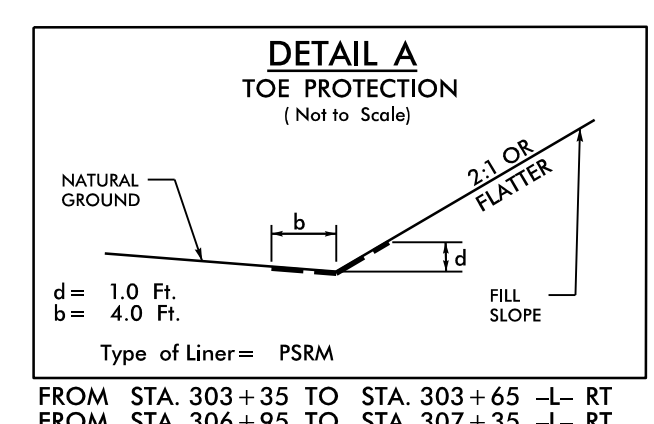

REVISIONS
 1/2/2018
 Sc_rdy_psh_02D-01_drawing-detailed.dwg
 11:58:00 AM