

RUTHERFORD

CLEVELAND

South Carolina

MAP 45

MAP 1

MAP 46





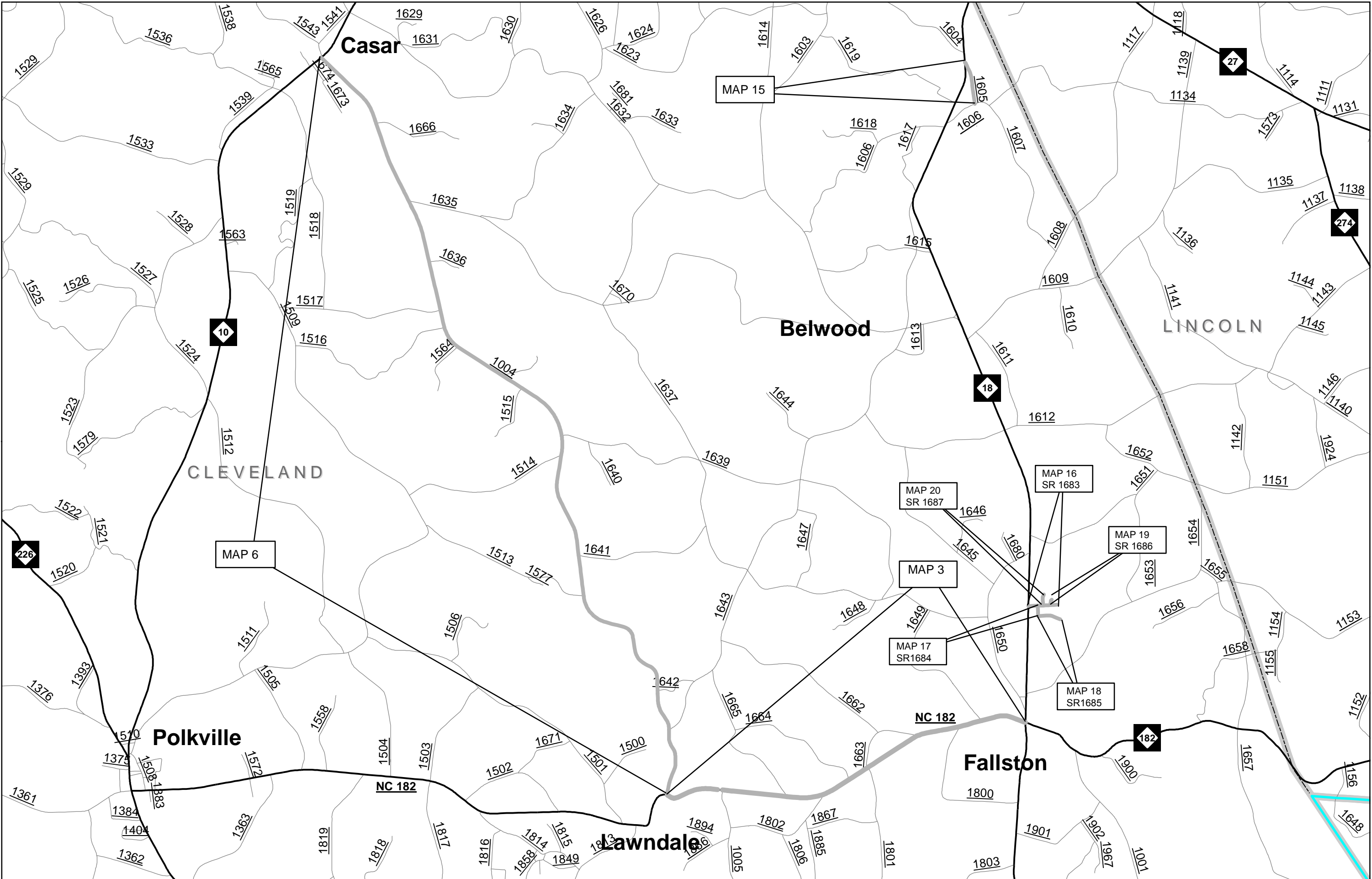

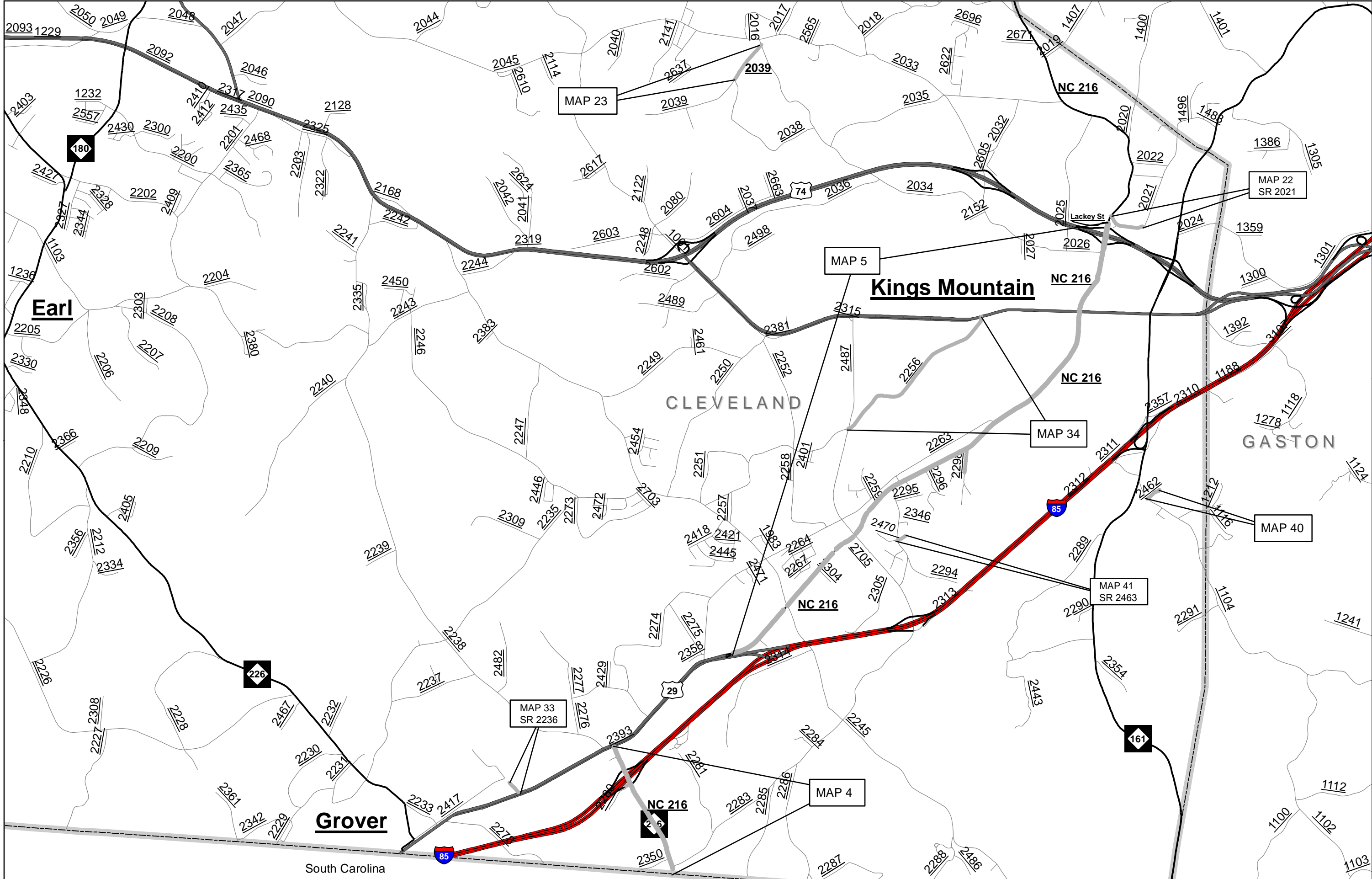

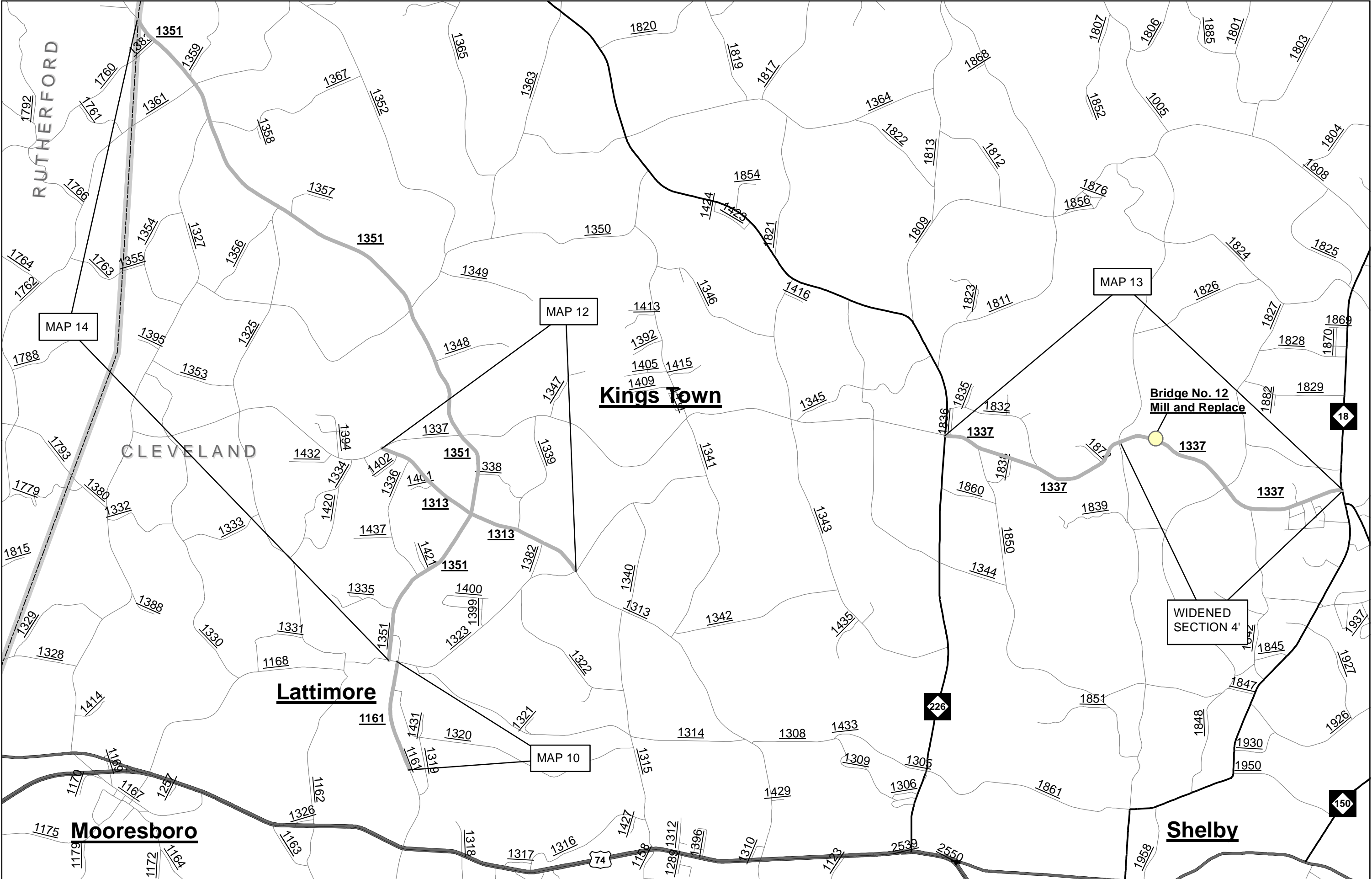



PROJ. REFERENCE NO.	SHEET NO.	TOTAL SHEETS
CLEVELAND CO. 2018-2019	7	
STATE PROJ. NO.	F.A. PROJ. NO.	DESCRIPTION
2018CPT.12.07.10231		
2018CPT.12.07.20231		

PAVEMENT SCHEDULE	
Y	SHOULDER RECONSTRUCTION
C1	PROP. APPROX. 1½" ASPHALT CONCRETE SURFACE COURSE, TYPE S9.5C, AT AN AVERAGE RATE OF 168 LBS. PER SQ. YD.
C2	PROP. APPROX. 1" ASPHALT CONCRETE SURFACE COURSE, TYPE S9.5B, AT AN AVERAGE RATE OF 110 LBS. PER SQ. YD.
E1	PROP. APPROX. 5.5" ASPHALT CONCRETE BASE COURSE, TYPE B25.0C, AT AN AVERAGE RATE OF 627 LBS. PER SQ. YD.
F1	ASPHALT SURFACE TREATMENT, MATCOAT #6M STONE
V1	MILL ASPHALT PAVEMENT APPROX. 1½" AS DIRECTED BY THE ENGINEER.
Z	INCIDENTAL MILLING

NOTE: PAVEMENT EDGE SLOPES ARE 1:1 UNLESS SHOWN OTHERWISE.  
MILL BRIDGE APPROACHES 100' TO PROVIDE A SMOOTH TRANSITION AS DIRECTED.  
MILL INTO GUTTER LINE WHERE SHOWN AND AS DIRECTED.  
MAINTAIN PROPER CROWN FOR DRAINAGE OF THE ROAD SURFACE.

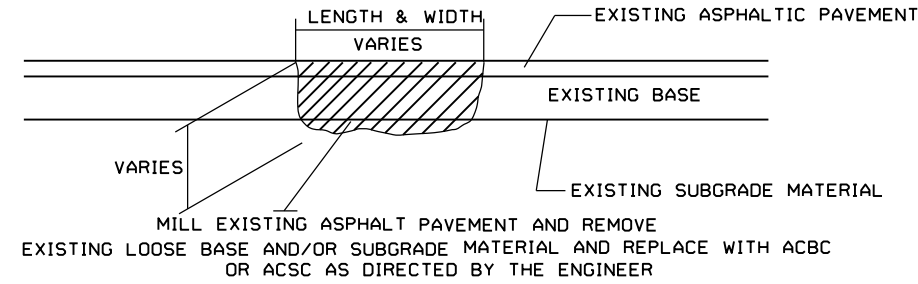

**PATCHING EXISTING PAVEMENT**

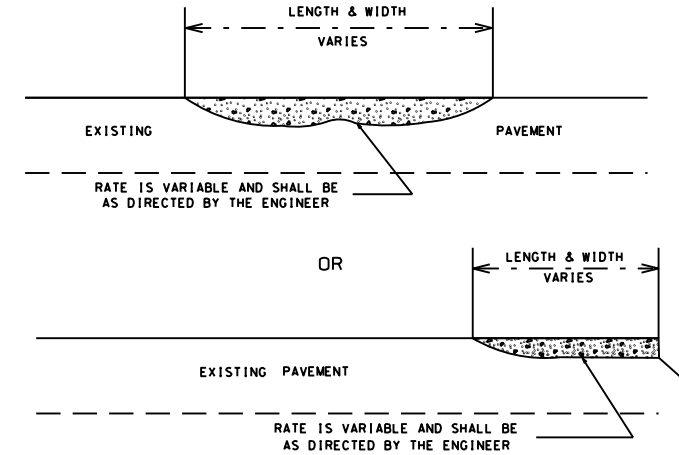

ASPHALT CONCRETE SURFACE COURSE  
TYPE S9.5B/S9.5C (LEVELING COURSE)

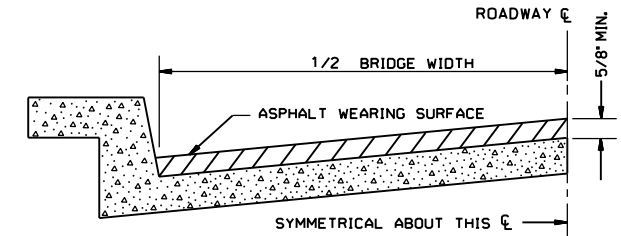

**BRIDGE HALF TYPICAL SECTION**

FOR BRIDGES WITH FLOOR DRAINS, CARE SHALL BE EXERCISED IN PLACING THE WEARING SURFACE AROUND FLOOR DRAINS SO AS NOT TO HINDER EFFECTIVE DRAINAGE. ALL DRAINS SHALL BE LEFT OPEN.

THE PROPOSED WEARING SURFACE SHALL VARY IN THICKNESS AS NECESSARY TO PROVIDE A SMOOTH RIDING SURFACE. A THICKNESS OF NOT LESS THAN 5/8" SHALL BE PROVIDED, THE MAXIMUM THICKNESS SHALL PREFERABLY BE 1-1/2" UNLESS IT IS IMPRACTICAL TO PROVIDE A SMOOTH RIDING SURFACE OTHERWISE.

**NOTES**

ALL UNPAVED S.R. ROADS TO BE SURFACED 50' FROM EDGE OF PAVEMENT OF MAIN PROJECT.  
ALL PAVED S.R. ROADS TO BE RESURFACED TO THE ENDS OF THE RADII, OR AS DIRECTED BY THE ENGINEER.  
EDGES, PAVEMENT WIDENING, INTERSECTIONS AND BRIDGE FLARES ARE INCLUDED IN THE TABLE OF QUANTITIES.  
SHOULDERS AND DITCHES ARE TO BE CONSTRUCTED BY OTHERS UNLESS OTHERWISE NOTED.  
BRIDGES TO BE RESURFACED AT LOCATIONS AND TO DEPTH AS DIRECTED BY THE ENGINEER.

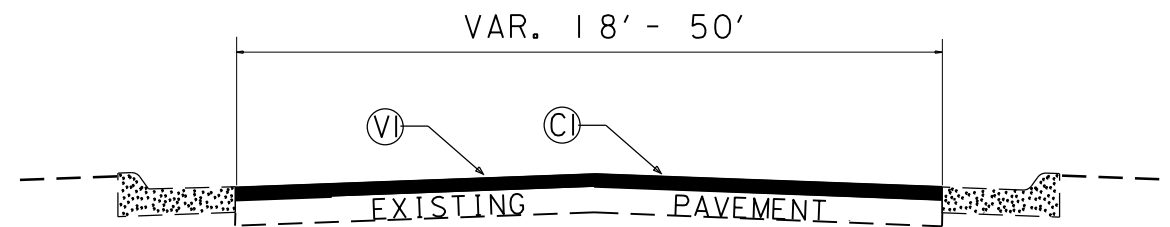

**TYPICAL SECTION NO. 1**

(MAP 5, 7, 8, 13, 14, 21, 22, 25, 34)

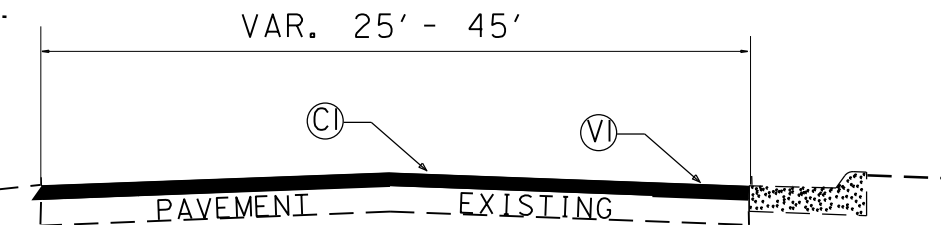

**TYPICAL SECTION NO. 3**

(MAP 3, 26, 34)

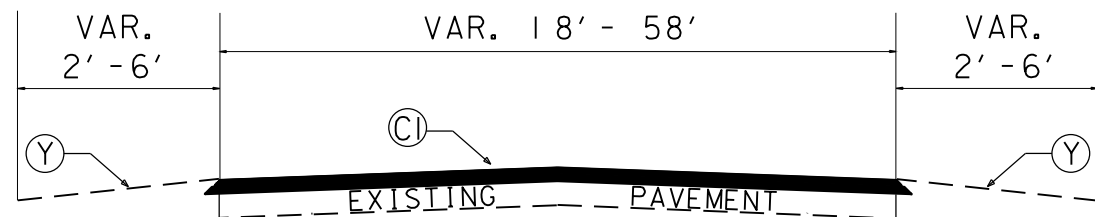

**TYPICAL SECTION NO. 2**

(MAP 2, 5, 9, 10, 13, 15, 22-26, 33-35, 50)

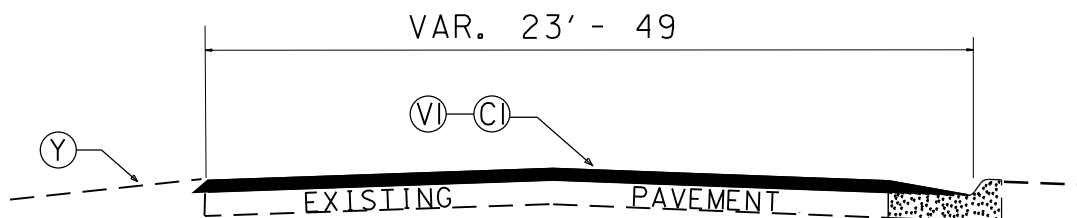

**TYPICAL SECTION NO. 4**

(MAP 5, 34)

**INCIDENTAL MILLING DETAILS**

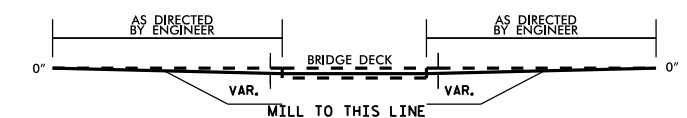

**BRIDGE PROFILE**

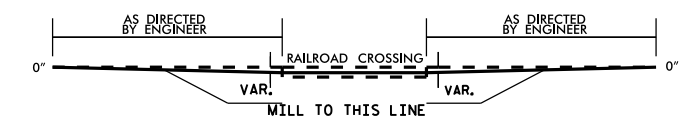

**RAILROAD PROFILE**

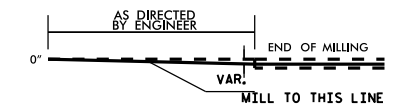

**END OF MILLING PROFILE**

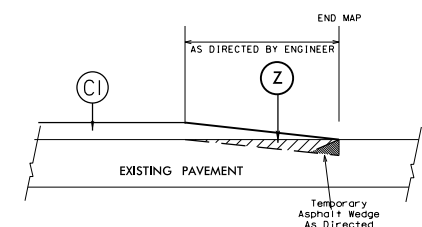

**TIE-IN MILLING DETAIL**

PROJ. REFERENCE NO.	SHEET NO.	TOTAL SHEETS
CLEVELAND CO. 2018-2019	8	
STATE PROJ. NO.	F. A. PROJ. NO.	DESCRIPTION
2018CPT.12.07.10231		
2018CPT.12.07.20231		

PAVEMENT SCHEDULE	
Y	SHOULDER RECONSTRUCTION
C1	PROP. APPROX. 1½" ASPHALT CONCRETE SURFACE COURSE, TYPE S9.5C, AT AN AVERAGE RATE OF 168 LBS. PER SQ. YD.
C2	PROP. APPROX. 1" ASPHALT CONCRETE SURFACE COURSE, TYPE S9.5B, AT AN AVERAGE RATE OF 110 LBS. PER SQ. YD.
E1	PROP. APPROX. 5.5" ASPHALT CONCRETE BASE COURSE, TYPE B25.0C, AT AN AVERAGE RATE OF 627 LBS. PER SQ. YD.
F1	ASPHALT SURFACE TREATMENT, MATCOAT #6M STONE
V1	MILL ASPHALT PAVEMENT APPROX. 1½" AS DIRECTED BY THE ENGINEER.
Z	INCIDENTAL MILLING

NOTE: PAVEMENT EDGE SLOPES ARE 1:1 UNLESS SHOWN OTHERWISE.  
MILL BRIDGE APPROACHES 100' TO PROVIDE A SMOOTH TRANSITION AS DIRECTED.  
MILL INTO GUTTER LINE WHERE SHOWN AND AS DIRECTED.  
MAINTAIN PROPER CROWN FOR DRAINAGE OF THE ROAD SURFACE.

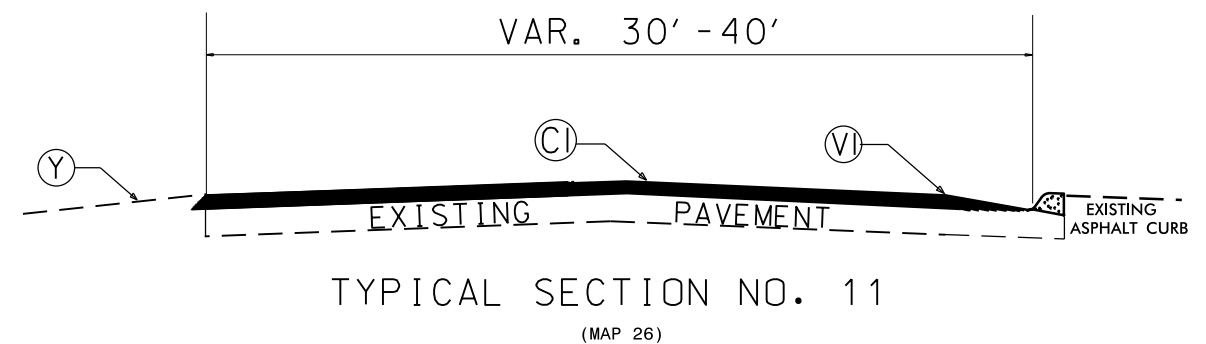
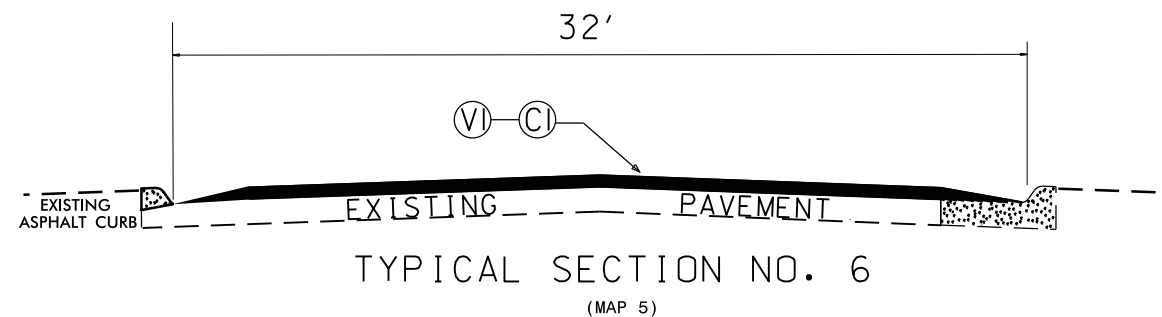
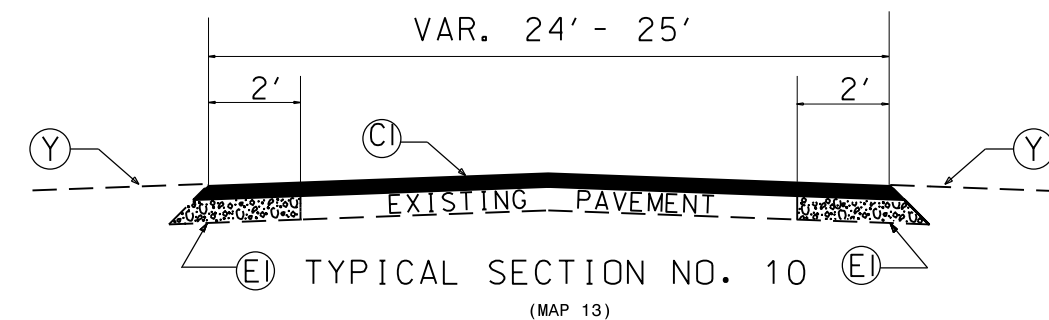
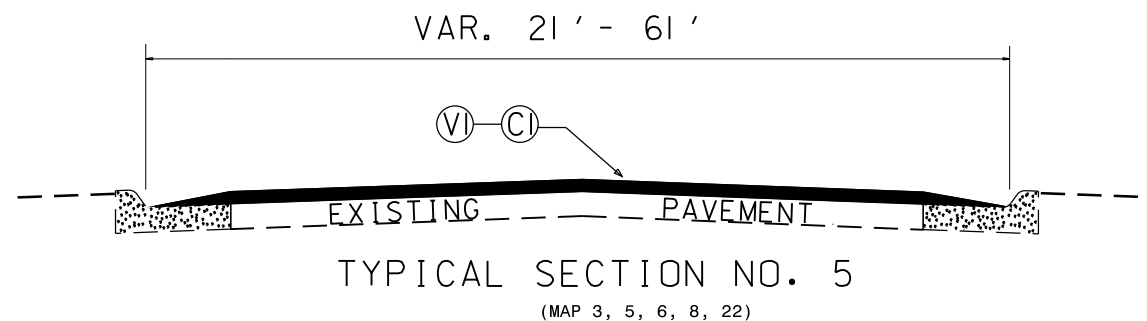
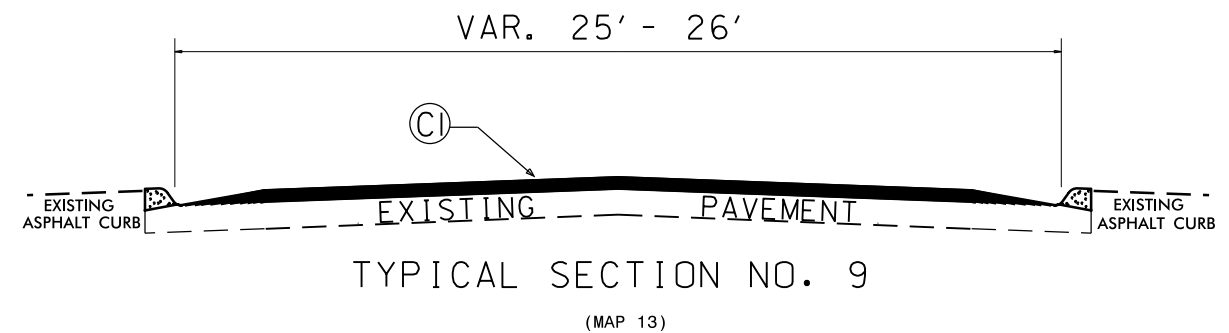
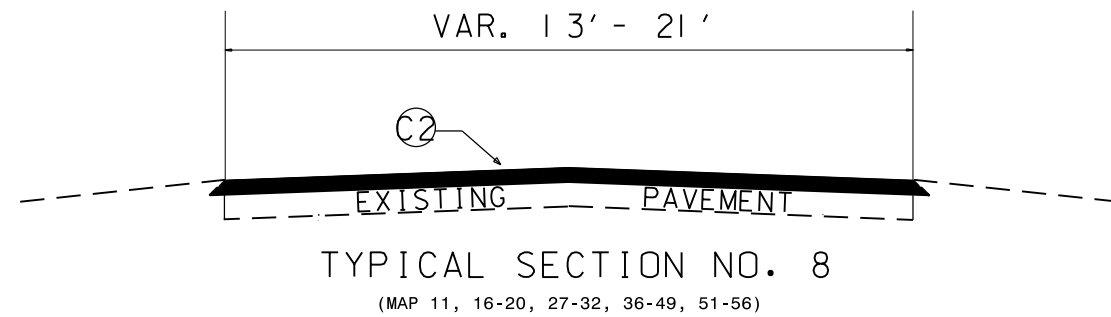
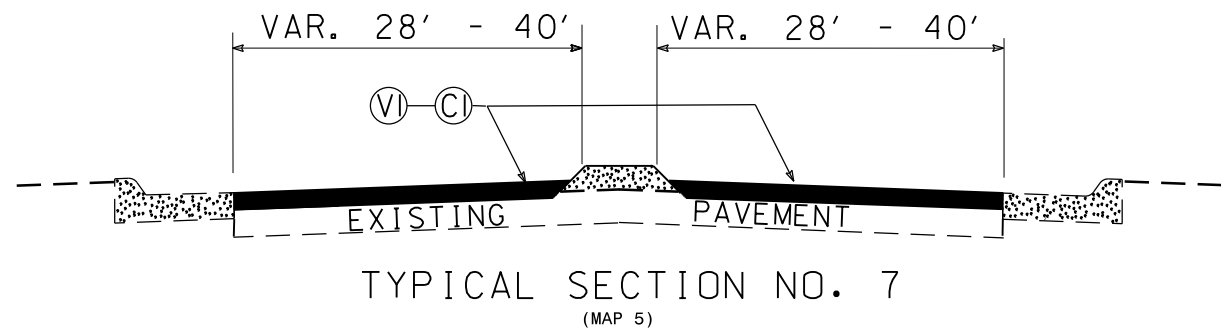



PAVEMENT SCHEDULE	
Y	SHOULDER RECONSTRUCTION
C1	PROP. APPROX. 1½" ASPHALT CONCRETE SURFACE COURSE, TYPE S9.5C, AT AN AVERAGE RATE OF 168 LBS. PER SQ. YD.
C2	PROP. APPROX. 1" ASPHALT CONCRETE SURFACE COURSE, TYPE S9.5B, AT AN AVERAGE RATE OF 110 LBS. PER SQ. YD.
E1	PROP. APPROX. 5.5" ASPHALT CONCRETE BASE COURSE, TYPE B25.0C, AT AN AVERAGE RATE OF 627 LBS. PER SQ. YD.
F1	ASPHALT SURFACE TREATMENT, MATCOAT #6M STONE
V1	MILL ASPHALT PAVEMENT APPROX. 1½" AS DIRECTED BY THE ENGINEER.
Z	INCIDENTAL MILLING

NOTE: PAVEMENT EDGE SLOPES ARE 1:1 UNLESS SHOWN OTHERWISE.  
MILL BRIDGE APPROACHES 100' TO PROVIDE A SMOOTH TRANSITION AS DIRECTED.  
MILL INTO GUTTER LINE WHERE SHOWN AND AS DIRECTED.  
MAINTAIN PROPER CROWN FOR DRAINAGE OF THE ROAD SURFACE.

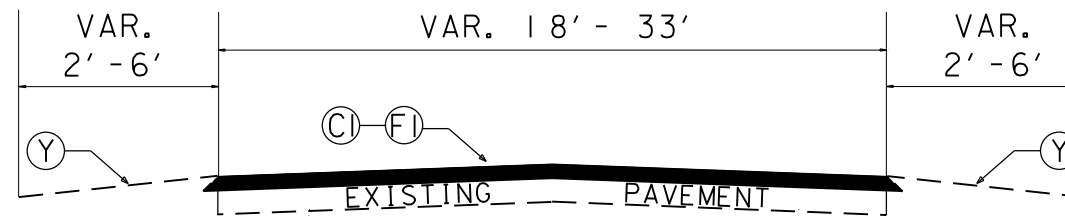

TYPICAL SECTION NO. 12

(MAP 1, 3, 4, 6, 7, 12)

PROJ. REFERENCE NO.	SHEET NO.	TOTAL SHEETS
CLEVELAND CO. 2018-2019	9	
STATE PROJ. NO.	F. A. PROJ. NO.	DESCRIPTION
2018CPT. 12.07.10231		
2018CPT. 12.07.20231		

- NOTES:  
 1) DETAIL DOES NOT APPLY TO OGAFB AND ULTRA-THIN BONDED WEARING COURSE.  
 2) BACKFILL SHOULDER WITH APPROVED MATERIAL.  
 3) THE SHOULDER WEDGE DEVICE MAY BE DISENGAGED AT PAVED DRIVEWAYS, SIDE STREETS, HIGH SHOULDERS, AND OTHER LOCATIONS NOT FEASIBLE TO CONSTRUCT AS APPROVED BY THE ENGINEER.

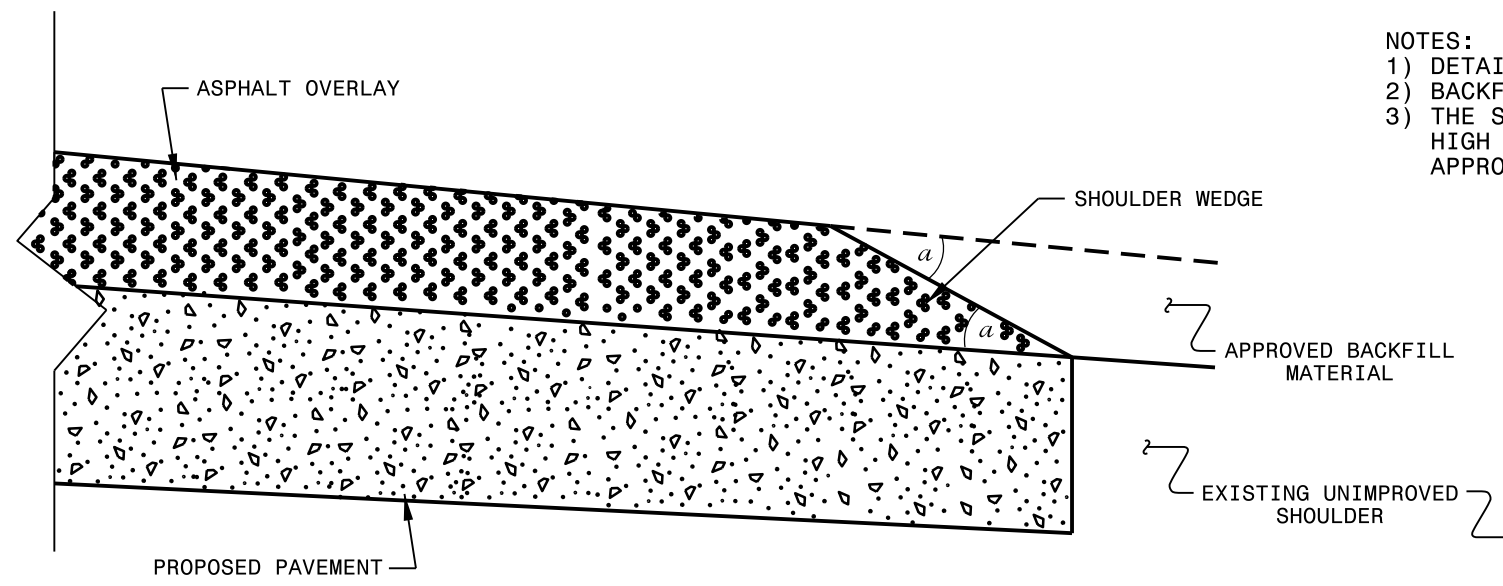

**SHOULDER WEDGE DETAIL**  
 (Resurfacing Projects w/ Widening or  
 with Existing Paved Shoulder having no dropoffs)

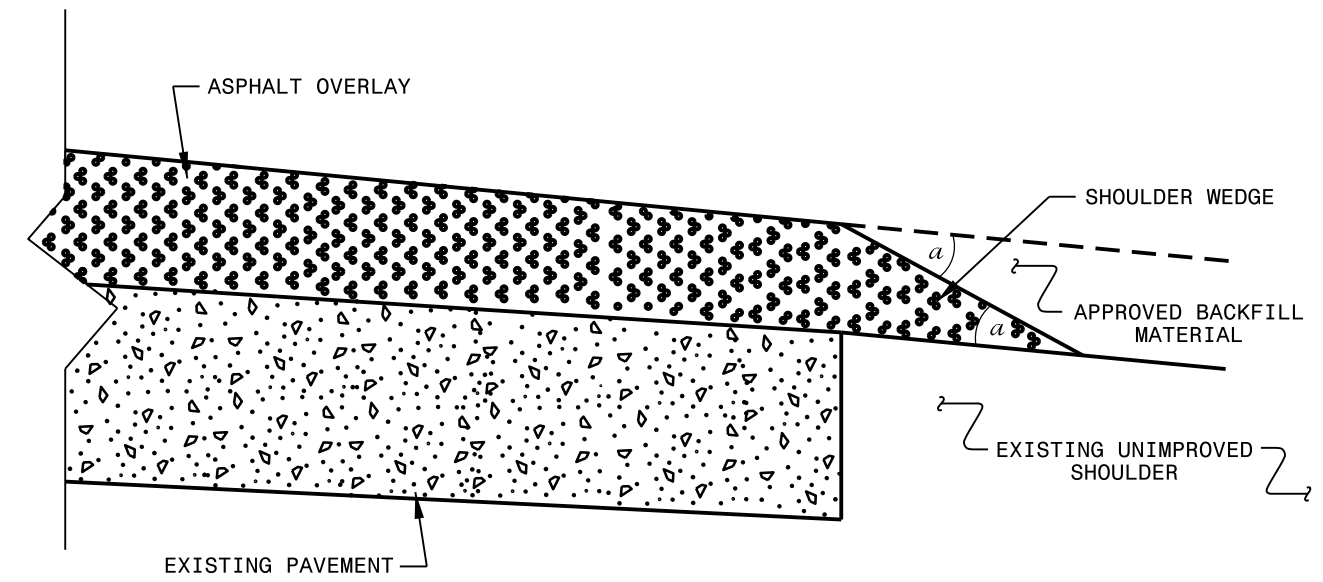

**SHOULDER WEDGE DETAIL**  
 (Resurfacing Projects w/ NO Widening)

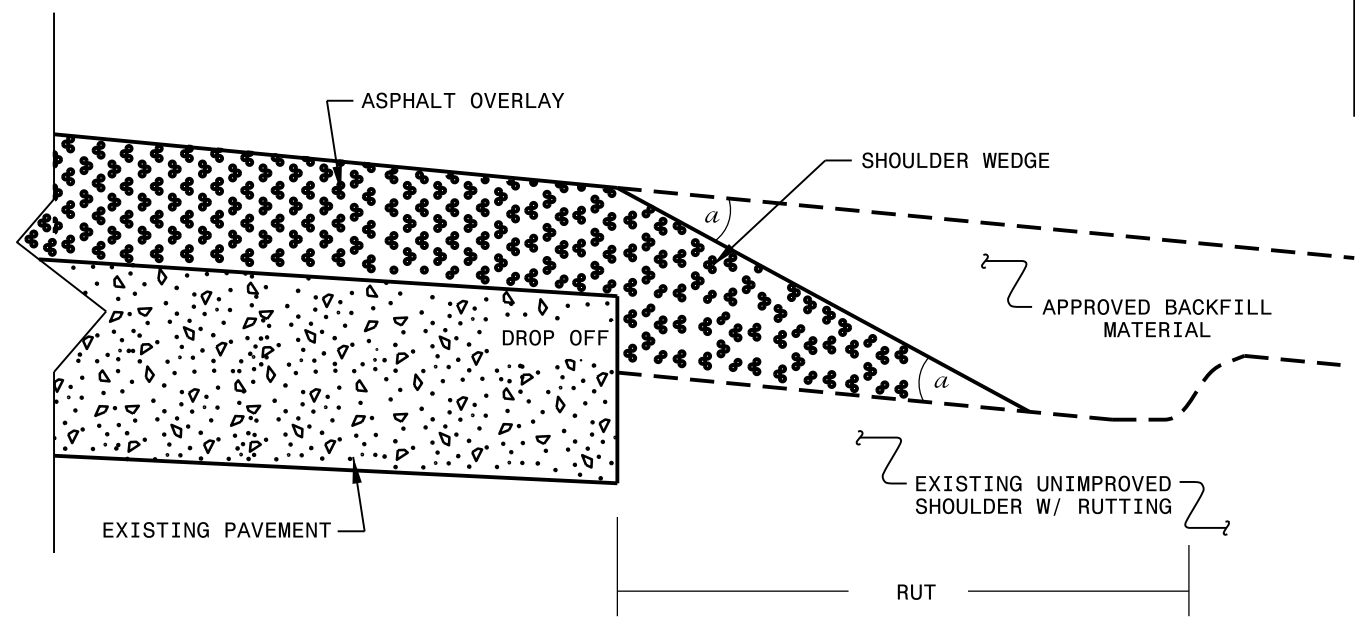

**SHOULDER WEDGE DETAIL**  
 (Resurfacing Adjacent to  
 Rutted Shoulder)

- SHOULDER WEDGE ANGLE = 30°

<b>CONTRACT STANDARDS AND DEVELOPMENT UNIT</b>		
Office 919-707-6950 FAX 919-250-4119		
<b>SHOULDER WEDGE DETAILS</b>		
ORIGINAL BY: T.SPELL	DATE: 7-19-11	
MODIFIED BY:	DATE: 2/2/16	
CHECKED BY:	DATE:	
FILE SPEC.: szusr/details/stand/shoulderwedgedetail.dgn		

22 JAN-2018 09:41  
 S:\Contracts\1000\Resurfacing Projects\Division 4\I-5937 Wilson March 2018\Revised Shoulder Wedge Detail.dgn  
 P:\piper\41\_CSD-21532

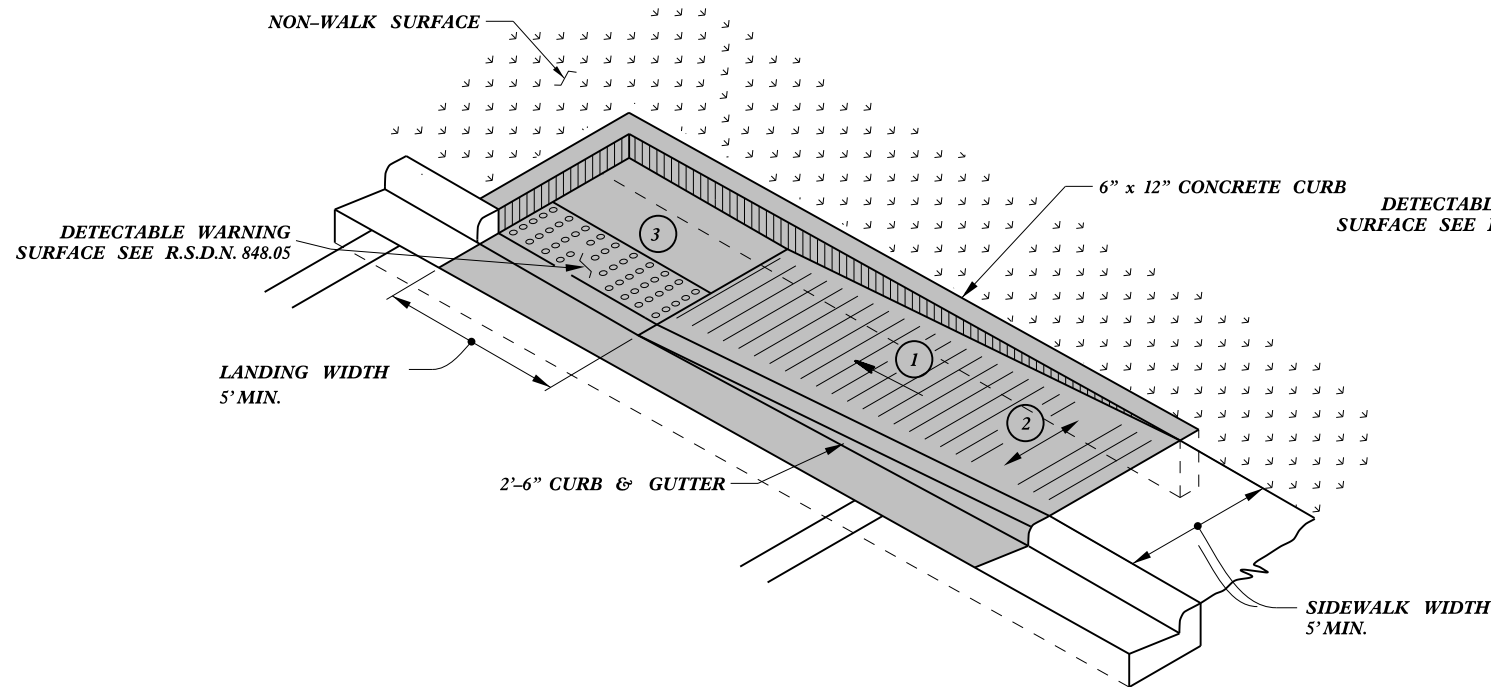

TYPE 1A

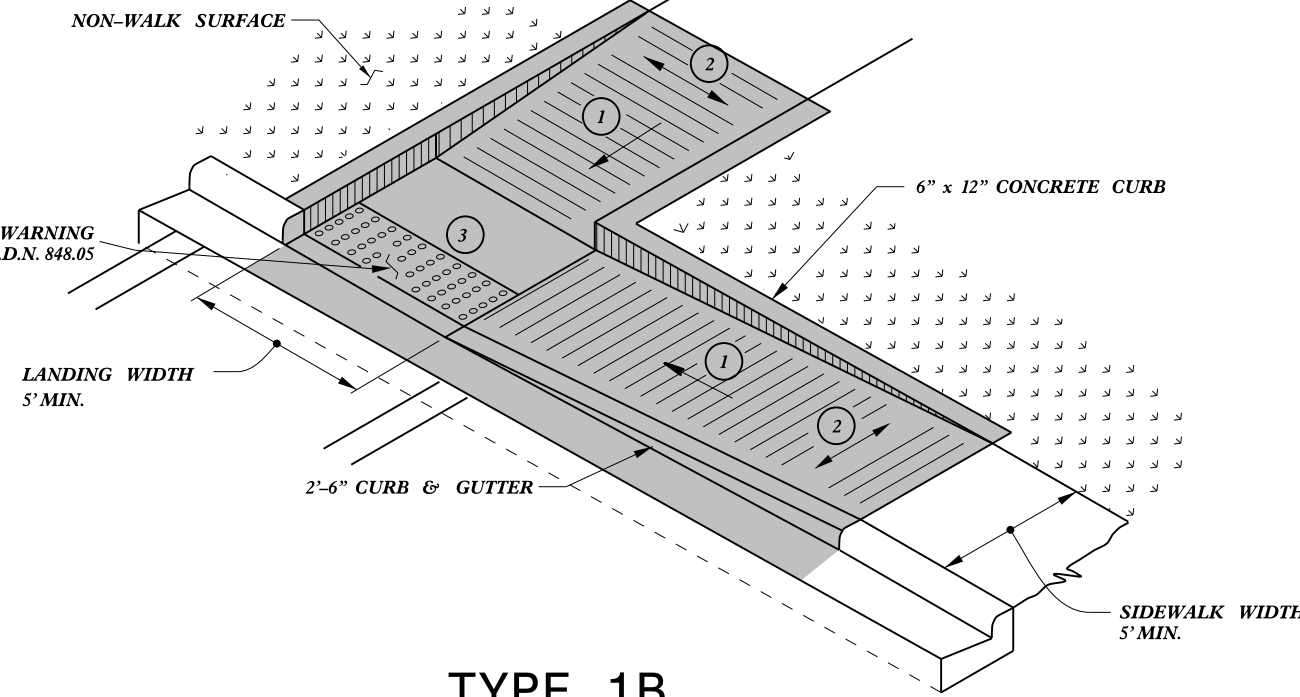

TYPE 1B

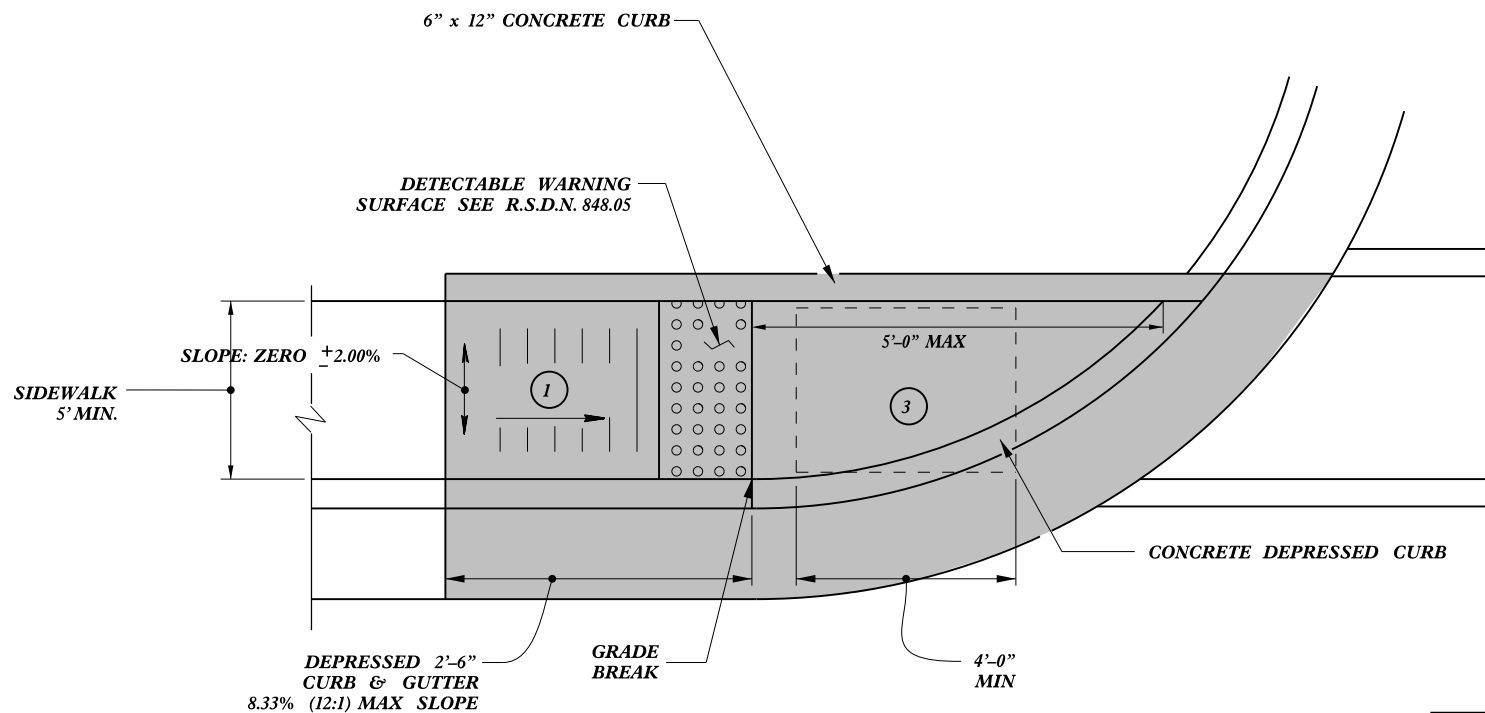

TYPE 1

PAY LIMITS FOR 1 CURB RAMP

- 1 8.33% (12:1) MAX RAMP SLOPE
- 2 CROSS SLOPE: 2.00%
- 3 CURB RAMPS REQUIRE A (4'-0") MINIMUM LANDING WITH A MAXIMUM CROSS SLOPE AND LONGITUDINAL SLOPE OF 2.00% WHERE PEDESTRIANS PERFORM TURNING MANEUVERS. SLOPE TO DRAIN TO CURB.

REFER TO ROADWAY STANDARD DRAWING NUMBER 848.05 SHEET 3 OF 3 FOR ALL RAMP NOTES

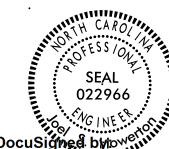

DocuSign by  
Joel S. Howerton

449E8E25522144F...  
11/18/2015

DOCUMENT NOT CONSIDERED FINAL UNLESS ALL SIGNATURES COMPLETED

<b>CONTRACT STANDARDS AND DEVELOPMENT UNIT</b>	
Office 919-707-6950	FAX 919-250-4119
<b>CURB RAMPS</b>	
Directional Ramps	
ORIGINAL BY: J.S. HOWERTON	DATE: 7/7/11
MODIFIED BY:	DATE:
CHECKED BY:	DATE:
FILE SPEC. stds/2012CurbRamp/CurbRampDetails.dwg	

5/14/99  
CONSTRUCTION USER NAME  
DATE

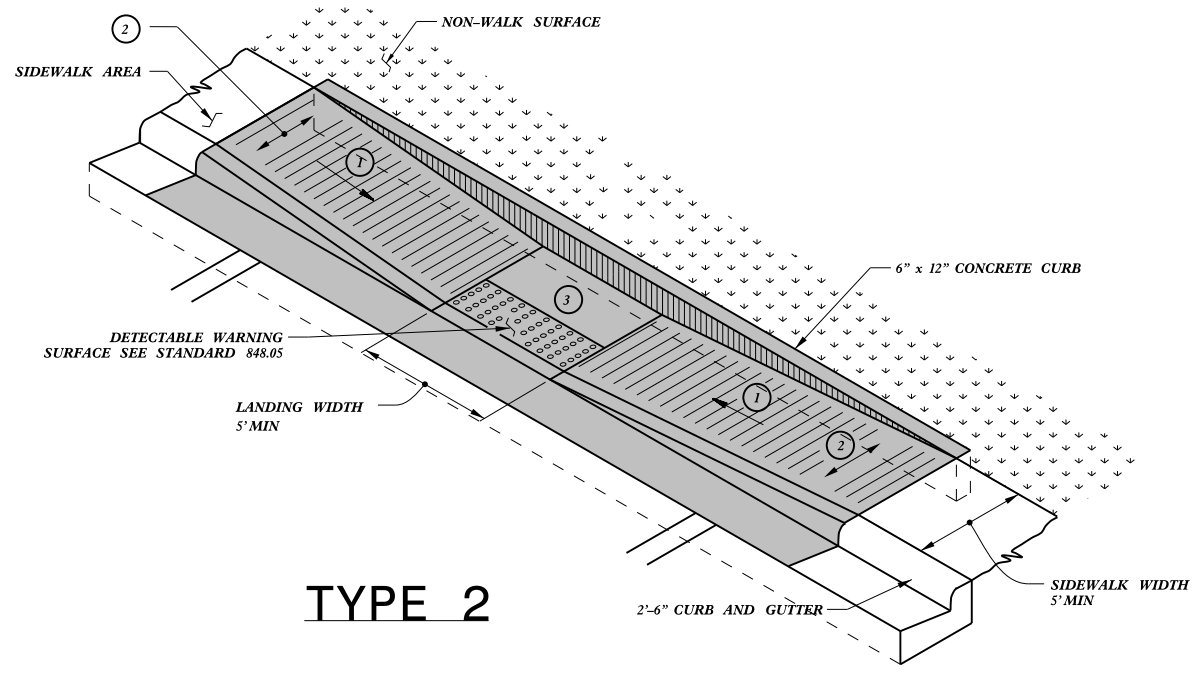

**TYPE 2**

PAY LIMITS FOR 1 CURB RAMP

- 1 8.33% (12:1) MAX RAMP SLOPE
- 2 CROSS SLOPE: 2.00%
- 3 CURB RAMPS REQUIRE A (4'-0") MINIMUM LANDING WITH A MAXIMUM CROSS SLOPE AND LONGITUDINAL SLOPE OF 2.00% WHERE PEDESTRIANS PERFORM TURNING MANEUVERS. SLOPE TO DRAIN TO CURB.

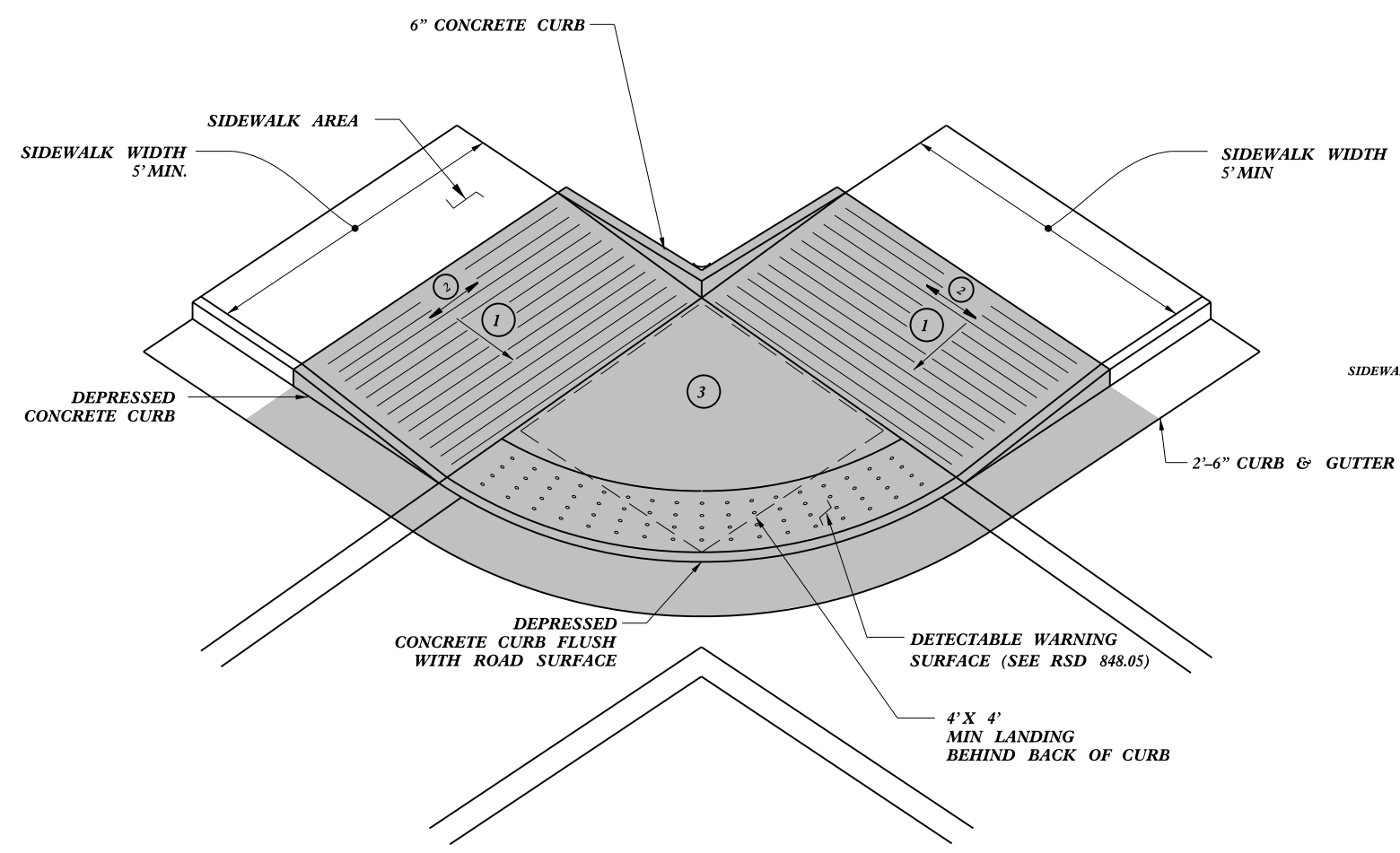

**TYPE 2A**

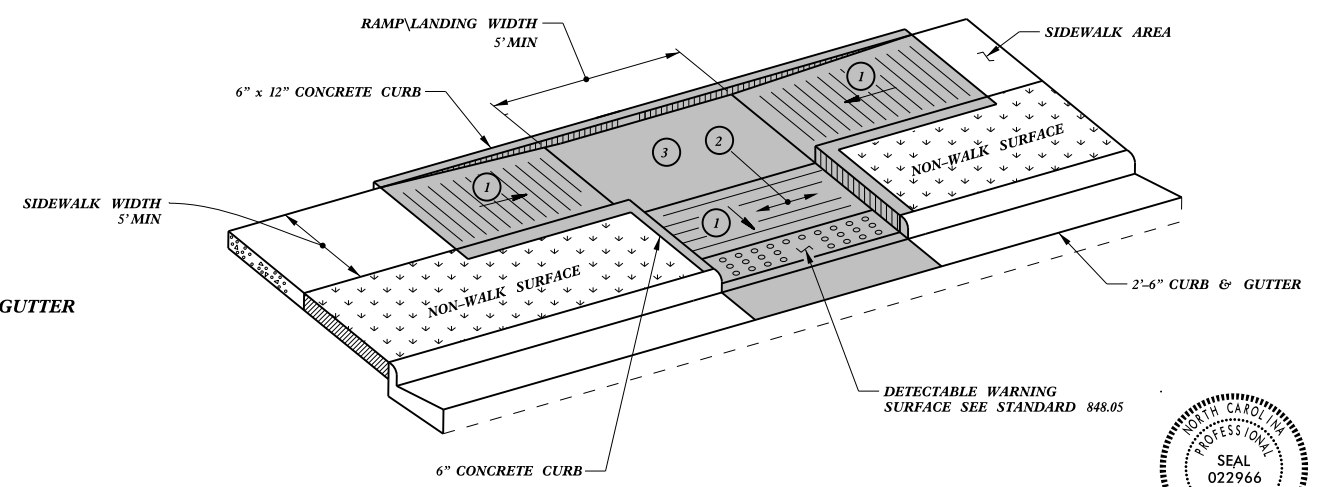

**TYPE 3**



11/18/2015

449E8E25522144E  
DOCUMENT NOT CONSIDERED FINAL UNLESS ALL SIGNATURES COMPLETED

**CONTRACT STANDARDS AND DEVELOPMENT UNIT**  
Office 919-707-6950 FAX 919-250-4119

**CURB RAMPS**  
Parallel Ramps

ORIGINAL BY: J.S. HOWERTON DATE: 7/7/11  
MODIFIED BY: \_\_\_\_\_ DATE: \_\_\_\_\_  
CHECKED BY: \_\_\_\_\_ DATE: \_\_\_\_\_  
FILE SPEC: stds/2012CurbRamp/CurbRampDetails.dwg

REFER TO ROADWAY STANDARD DRAWING NUMBER 848.05 SHEET 3 OF 3 FOR ALL RAMP NOTES

5/14/99  
SYTIME  
CONSTRUCTION  
SERIALS

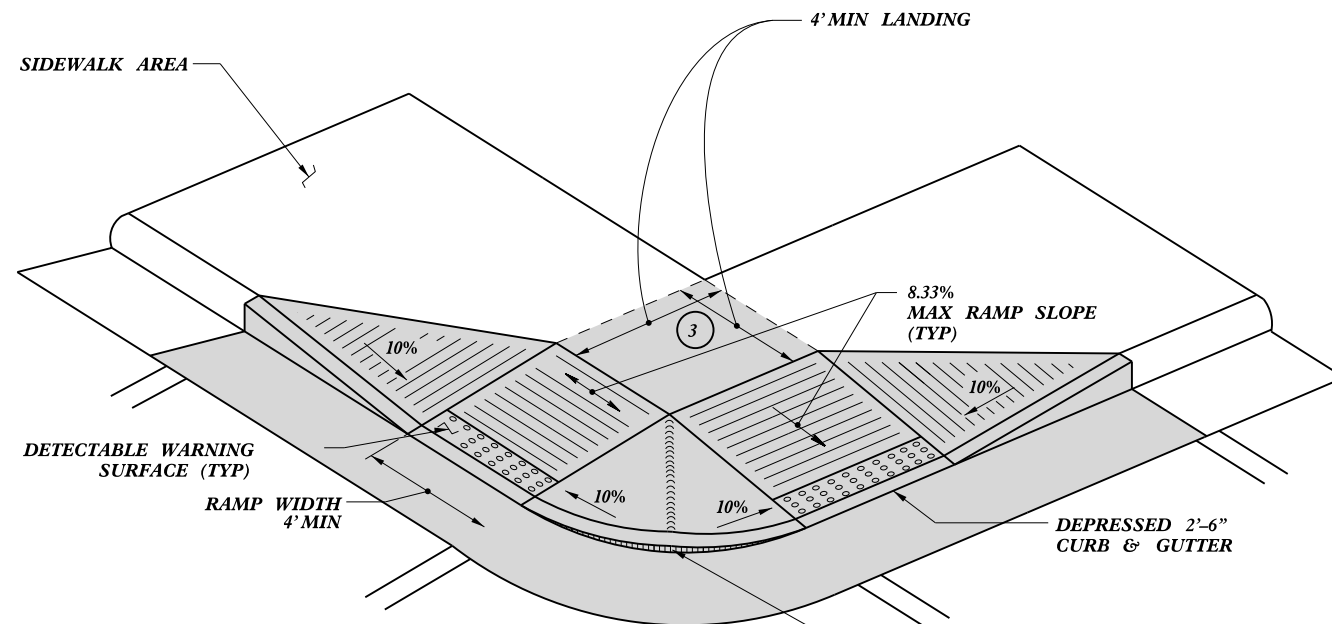

**TYPE 4**

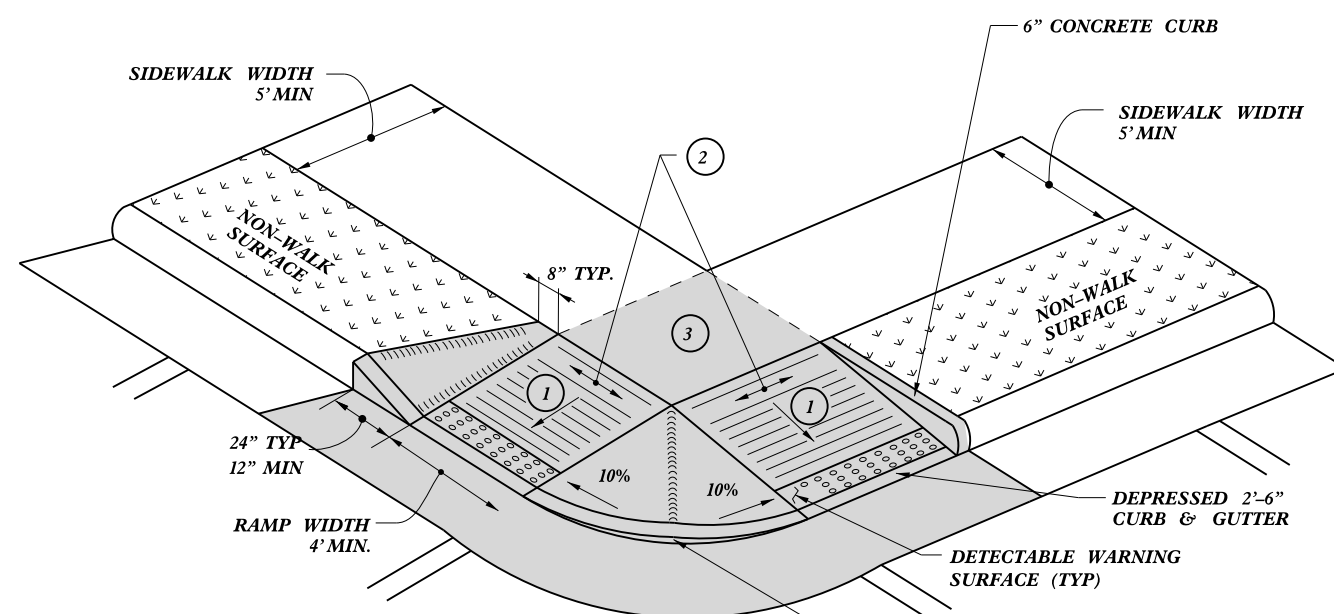

**TYPE 4A**

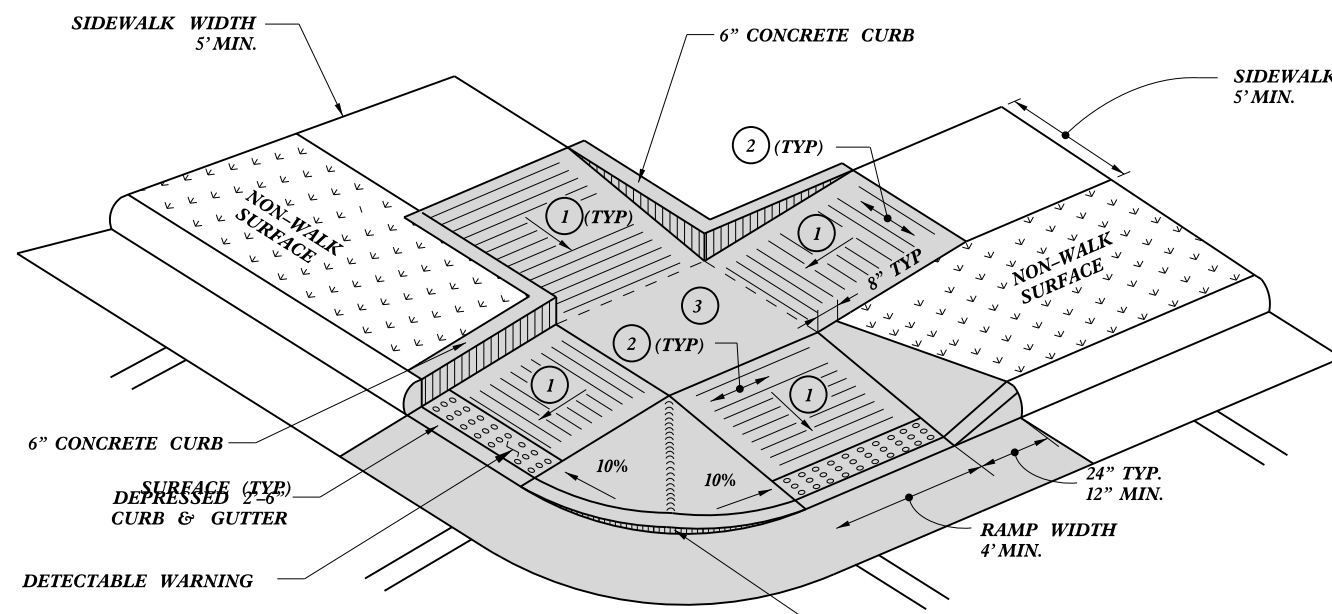

**TYPE 5**

PAY LIMITS FOR 2 CURB RAMPS

- 1 8.33% (12:1) MAX RAMP SLOPE
- 2 CROSS SLOPE: 2.00%
- 3 CURB RAMPS REQUIRE A (4'-0") MINIMUM LANDING WITH A MAXIMUM CROSS SLOPE AND LONGITUDINAL SLOPE OF 2.00% WHERE PEDESTRIANS PERFORM TURNING MANEUVERS. SLOPE TO DRAIN TO CURB.

DocuSigned by:  
*Joel S Howerton*  
449E8E25522144F...



11/18/2015

DOCUMENT NOT CONSIDERED FINAL UNLESS ALL SIGNATURES COMPLETED

**CONTRACT STANDARDS AND DEVELOPMENT UNIT**  
Office 919-707-6950 FAX 919-250-4119

**CURB RAMPS**  
Shared Landing

ORIGINAL BY: J.S. HOWERTON DATE: 7/7/11  
MODIFIED BY: DATE:   
CHECKED BY: DATE:   
FILE SPEC. :stds/2012CurbRamp/CurbRampDetails.dwg

REFER TO ROADWAY STANDARD DRAWING NUMBER 848.05 SHEET 3 OF 3 FOR ALL RAMP NOTES

5/14/199





## URBAN / SUBURBAN WORKZONES

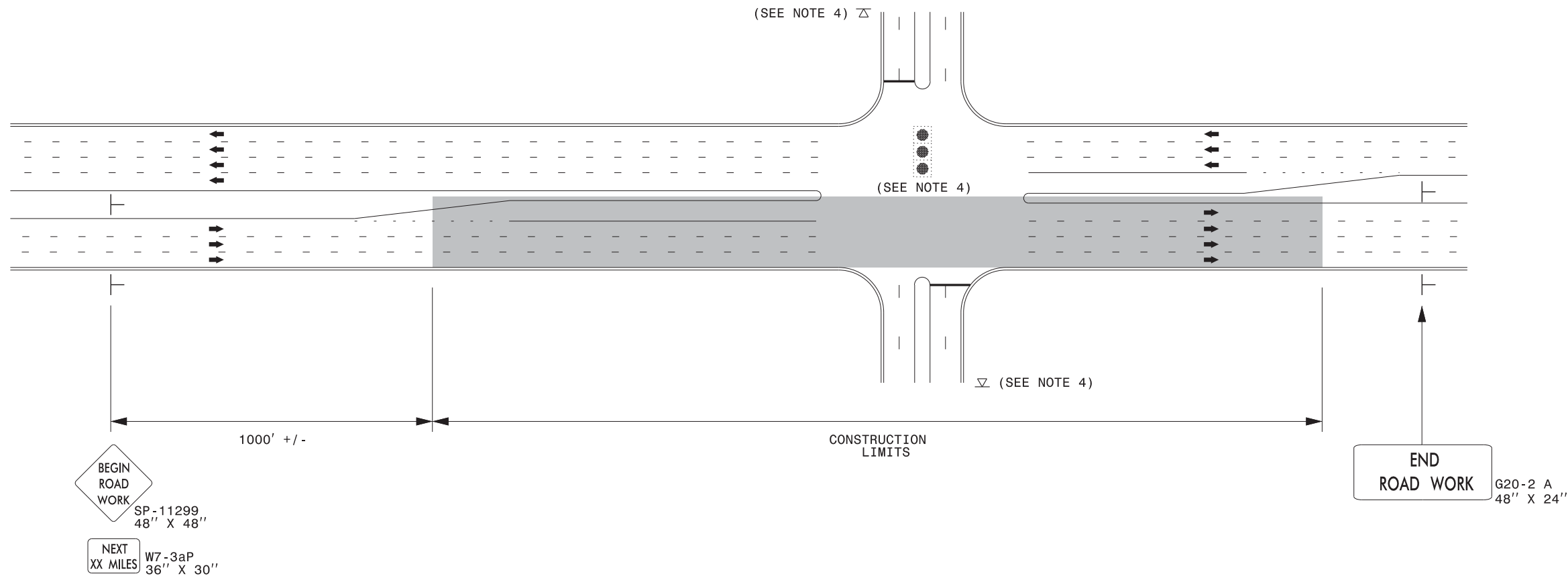

**NOTES:**

- 1) 48" x 48" SIZED SIGNS (SP- 11299) MAY BE REDUCED TO 36" X 36" ON ROADWAYS WITH SPEED LIMITS OF 40 MPH OR LESS.
- 2) MOUNT SIGNS THAT ARE LARGER THAN 10 SQUARE FEET IN AREA ON TWO OR MORE WOOD OR U-CHANNEL SUPPORTS. PERFORATED SQUARE TUBING SUPPORT SYSTEMS MAY SUPPORT LARGER AREAS ON A SINGLE SUPPORT. FOLLOW MANUFACTURER'S RECOMMENDATIONS. THESE SYSTEMS SHALL BE NCHRP 350 COMPLIANT AND NCDOT APPROVED.
- 3) ADVANCE WARNING SIGNS NOT REQUIRED ON NON-SIGNALIZED SIDE STREETS.
- 4) MAY USE LAW ENFORCEMENT TO CONTROL TRAFFIC AT SIGNALIZED INTERSECTIONS AS DIRECTED BY THE ENGINEER. PROVIDE PORTABLE "ROAD WORK AHEAD" (W20-1) SIGNS 500' IN ADVANCE ALONG BOTH APPROACHES FROM THE SIDE STREETS WHEN PAVING PROCEEDS THROUGH THE INTERSECTION.
- 5) LATERAL CLEARANCE AT ALL SIGN LOCATIONS SHALL BE 2' AS MEASURED FROM THE EDGE OF PAVEMENT OR THE FACE OF THE CURB. WHEN UNABLE TO OBTAIN THE LATERAL CLEARANCE WITHIN THE MEDIAN AREA USE SHOULDER MOUNTS ONLY.
- 6) SIGN MOUNT LOCATIONS SHALL NOT BLOCK SIDEWALKS OR DRIVEWAYS.
- 7) IF STATIONARY GENERAL WARNING SIGNS ARE USED, THEY WILL BE PAID FOR PER SECTION 104 OF THE NCDOT STANDARD SPECIFICATIONS AS EXTRA WORK.
- 8) IF MILLED AREAS ARE NOT PAVED BACK BY THE END OF THE WORK DAY, PORTABLE SIGNS SHALL BE USED TO WARN DRIVERS OF THE PRESENT CONDITIONS. THESE ARE TO INCLUDE, BUT NOT LIMITED TO "ROUGH ROAD" W8-8, "UNEVEN LANES" W8-11, "GROOVED PAVEMENT" W8-15 w/MOTORCYCLE PLAQUE MOUNTED BELOW. THESE ARE TO BE DOUBLE INDICATED ON MULTI-LANE ROADWAYS WITH SPEED LIMITS 45 MPH AND GREATER WHERE LATERAL CLEARANCE CAN BE OBTAINED WITHIN THE MEDIAN AREAS. THESE PORTABLE SIGNS ARE INCIDENTAL TO THE OTHER ITEMS OF WORK INCLUDED IN THE TEMPORARY TRAFFIC CONTROL (LUMP SUM) PAY ITEM.

**LEGEND**

- ┆ STATIONARY SIGN
- ➔ DIRECTION OF TRAFFIC FLOW

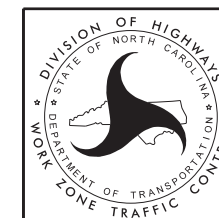

**RESURFACING ADVANCE  
WARNING SIGNS FOR  
URBAN / SUBURBAN  
FACILITIES**



# SIGNING FOR RESURFACING PROJECTS

**LEGEND**  
 ┆ STATIONARY SIGN  
 ← DIRECTION OF TRAFFIC FLOW

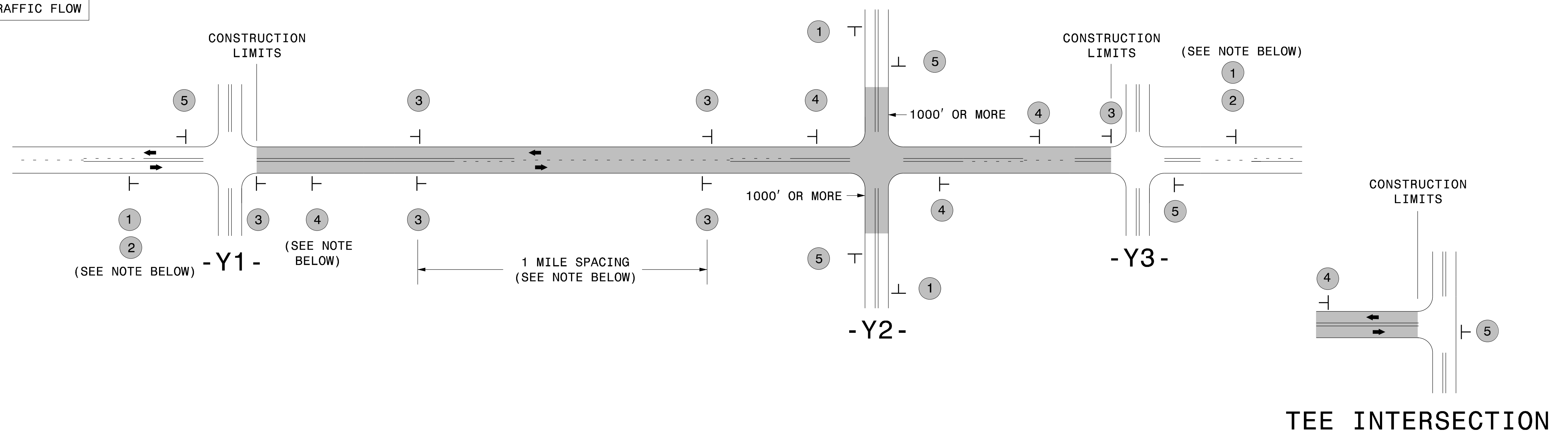

## MAINLINE (-L-) SIGNING

## -Y- LINE SIGNING

SIGNING NOTES AND PLACEMENT PER DIRECTION	1		PLACE 1000' PRIOR TO BEGINNING OF CONSTRUCTION LIMITS. ONLY USED ON -Y- LINES IF RESURFACING LIMITS EXTEND 1000' ALONG -Y- LINE.	<p>NO REQUIRED STATIONARY SIGNING FOR THE FOLLOWING -Y- LINE CONDITIONS:</p> <ol style="list-style-type: none"> <li>1) LESS THAN 1000' OF RESURFACING ALONG -Y- LINE</li> <li>2) SUBDIVISION ROADS</li> <li>3) DEAD END ROADS</li> </ol> <p>WHEN PAVING/CONSTRUCTION ACTIVITIES PROCEED ACROSS AN UNSIGNED -Y- LINE, PORTABLE ADVANCE WARNING SIGNS SHALL BE USED ALONG THE -Y- LINE AS SHOWN BELOW. REMOVE UPON COMPLETION OF WORK.</p> <div style="display: flex; justify-content: space-around;"> <div style="text-align: center;">             W20-1 48" X 48"            PLACED 500' IN ADVANCE OF FLAGGER.         </div> <div style="text-align: center;">             W20-7 A 48" X 48"            PLACED 250' IN ADVANCE OF FLAGGER.         </div> </div>
	2		#2 SIGN ONLY USED WHEN CONSTRUCTION LIMITS ARE 2 OR MORE MILES IN LENGTH. ROUND UP TO NEXT WHOLE NUMBER. (NO FRACTIONAL OR DECIMAL NUMBERS)	
	3		- PLACE INITIALLY AT THE CONSTRUCTION LIMITS AND SPACE 1 MILE APART THEREAFTER. - AT TEE INTERSECTIONS INSTALL INITIALLY 1/2 MILE FROM INTERSECTION AND SPACE 1 MILE APART THEREAFTER.	
	4		- THESE ARE FOR -Y- LINES THAT ARE "THROUGH" ROADWAYS. - DEAD END AND SUBDIVISION ROADS ARE NOT "THROUGH" ROADWAYS. - INSTALL 500' +/- FROM EACH -Y- LINE APPROACH AS SHOWN ABOVE. - FOR MULTIPLE -Y- LINES THAT ARE SEPARATED BY 0.25 MILES OR LESS, TREAT AS A SINGLE UNIT AND INSTALL WITHIN 500' OF EACH APPROACH. - A MAXIMUM OF 2 SIGN SETS PER MILE. DO NOT INSTALL WHEN -Y- LINES ARE WITHIN 0.5 MILES FROM "END ROAD WORK" SIGN. - FOR TEE INTERSECTIONS, INSTALL WITHIN 500' +/- OF THE INTERSECTION ALONG -L- LINE.	
	5		PLACE 500' FOLLOWING THE END OF CONSTRUCTION LIMITS OR AS SHOWN WHEN WORK ENDS AT A 3-WAY TEE INTERSECTION.	

THE ABOVE SIGNS ARE ALL THAT ARE REQUIRED FOR A CONTRACTOR TO BEGIN A RESURFACING CONTRACT. ANY ADDITIONAL SIGNS REQUESTED BY NCDOT DIVISIONS SHALL BE INSTALLED WITHIN 7 BUSINESS DAYS OF THE START OF CONTRACT WORK.

**MAPS LESS THAN 2 MILES**

FOR RESURFACING MAPS WITH CONSTRUCTION LIMITS LESS THAN 2 MILES IN LENGTH, NO STATIONARY SIGNS ARE REQUIRED. USE PORTABLE "ROAD UNDER CONSTRUCTION" OR "ROAD WORK AHEAD" SIGNS IN LIEU OF STATIONARY ADVANCE WARNINGS SIGNS.

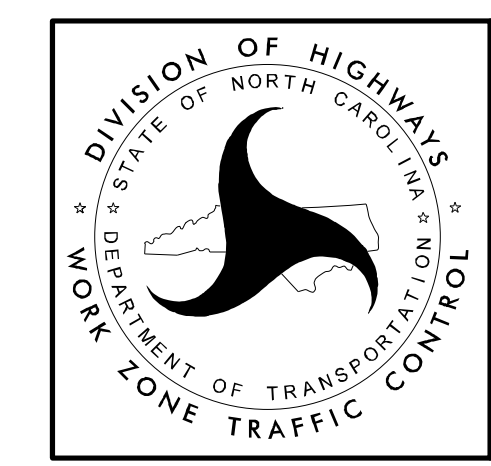

**ADVANCE WARNING SIGNS FOR RURAL AND SUBURBAN 2-LANE ROADWAY RESURFACING**

### High Speed Detection (≥40 mph)

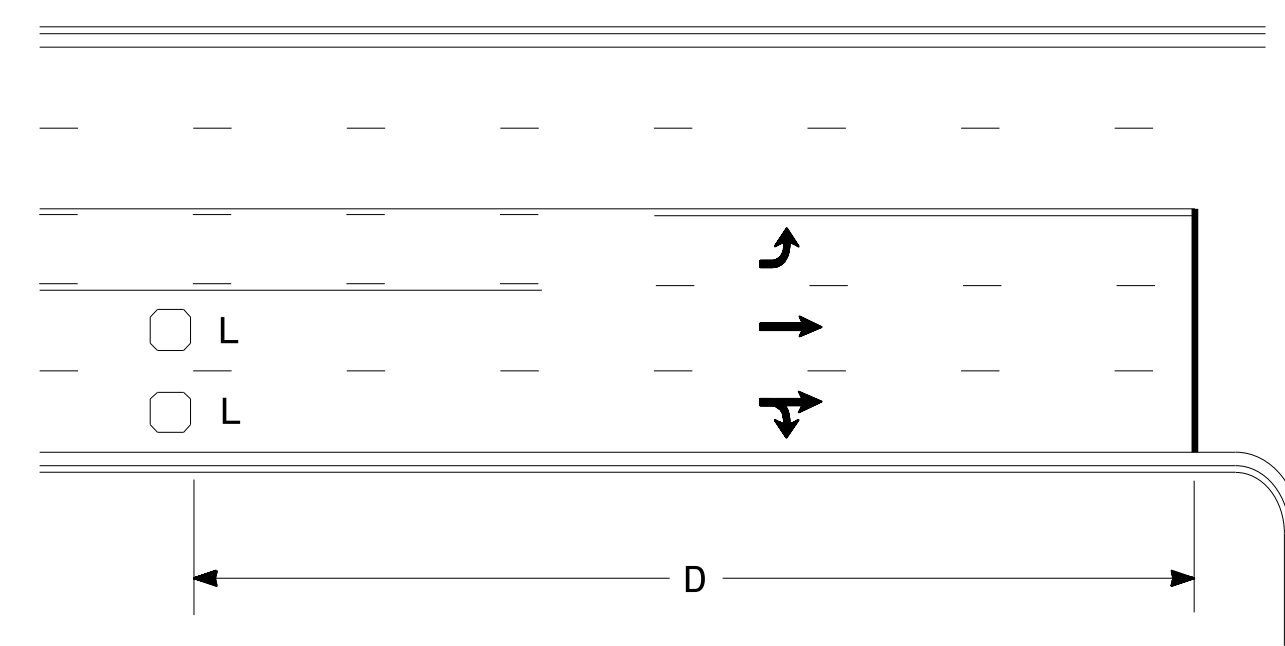

Speed Limit mph	D ft
40	250
45	300
50	355
55	420

L = 6ft X 6ft  
Wired in series for TS1  
Controllers  
Wired separately for TS2,  
170, and 2070L Controllers

Volume Density Operation

OR

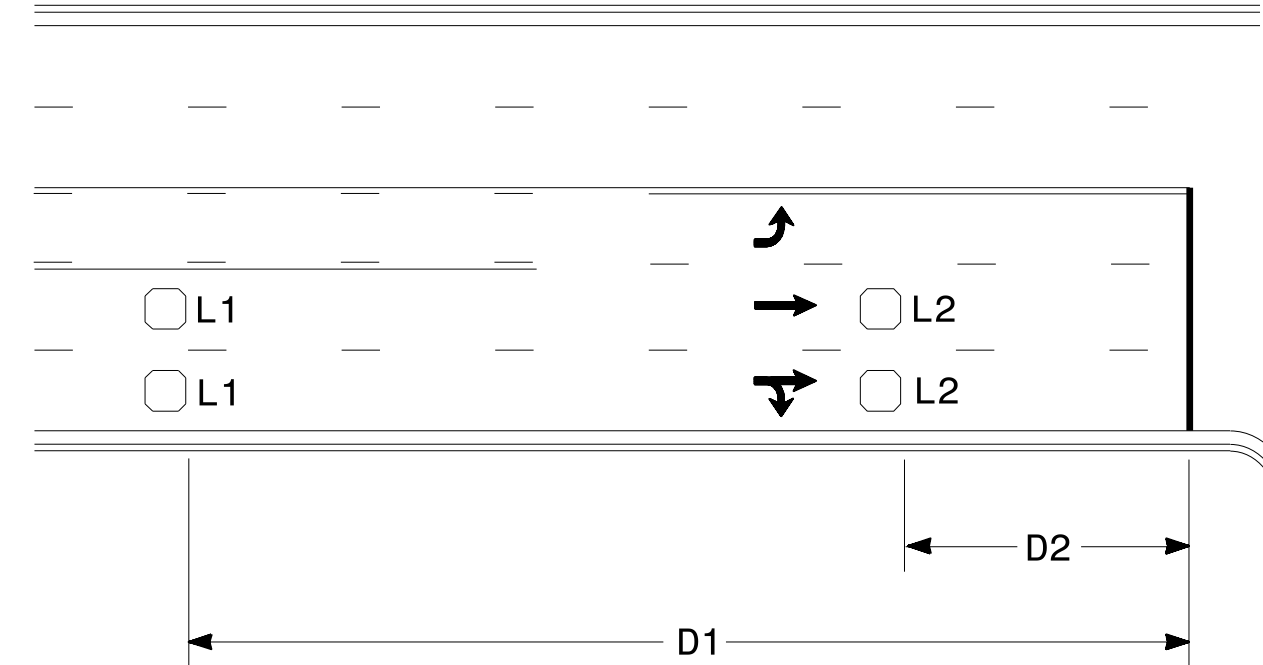

Speed Limit mph	D1 ft	D2 ft
40	250	80
45	300	90
50	355	100
55	420	110

L1 = 6ft X 6ft  
Wired in series  
L2 = 6ft X 6ft  
Wired in series

"Stretch" Operation

### Low Speed Detection (≤35 mph)

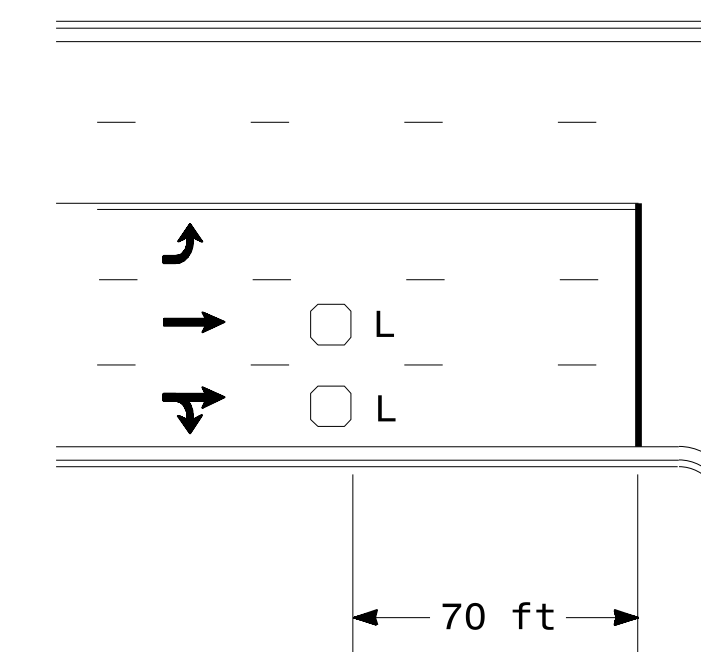

L = 6ft X 6ft  
Wired in series

OR

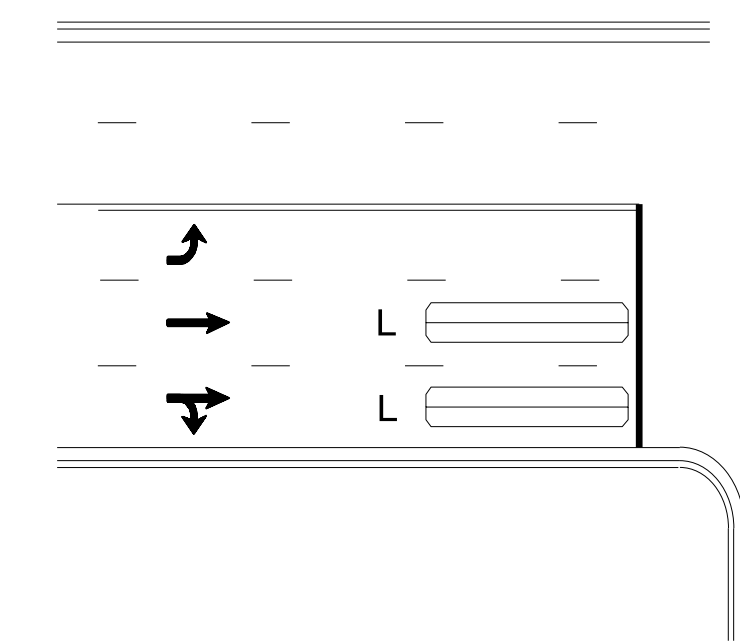

L = 6ft X 40ft  
Quadrupole loop, wired separately

### Left Turn Lane Detection

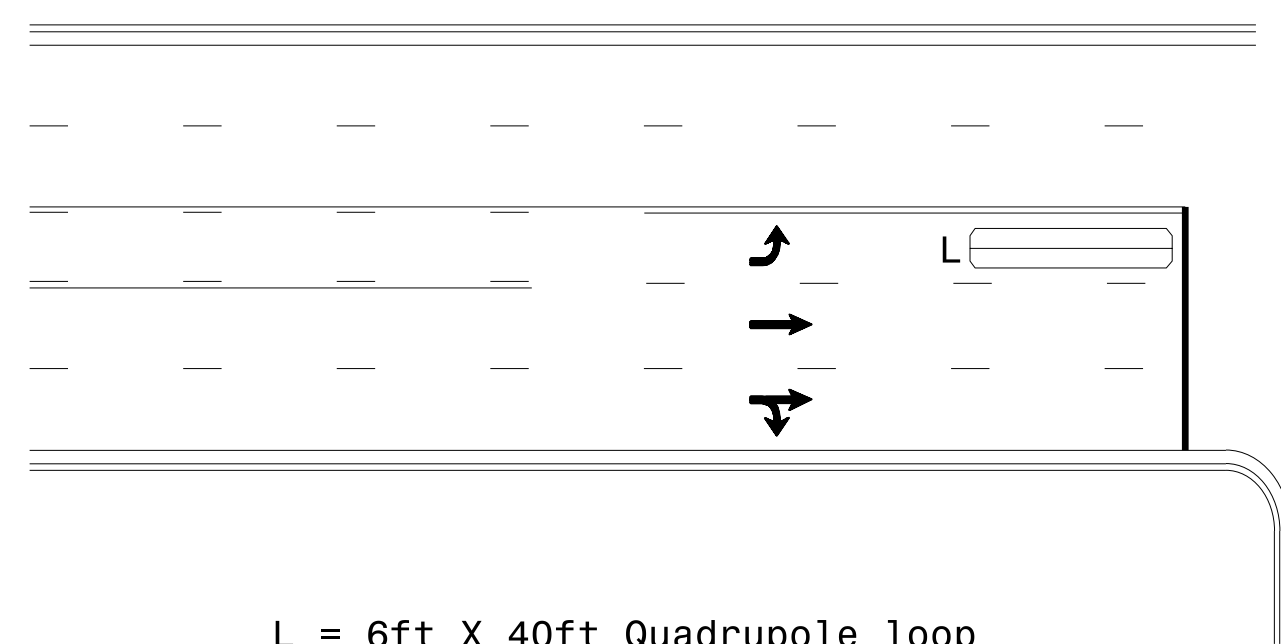

L = 6ft X 40ft Quadrupole loop

Presence Loop Detection

OR

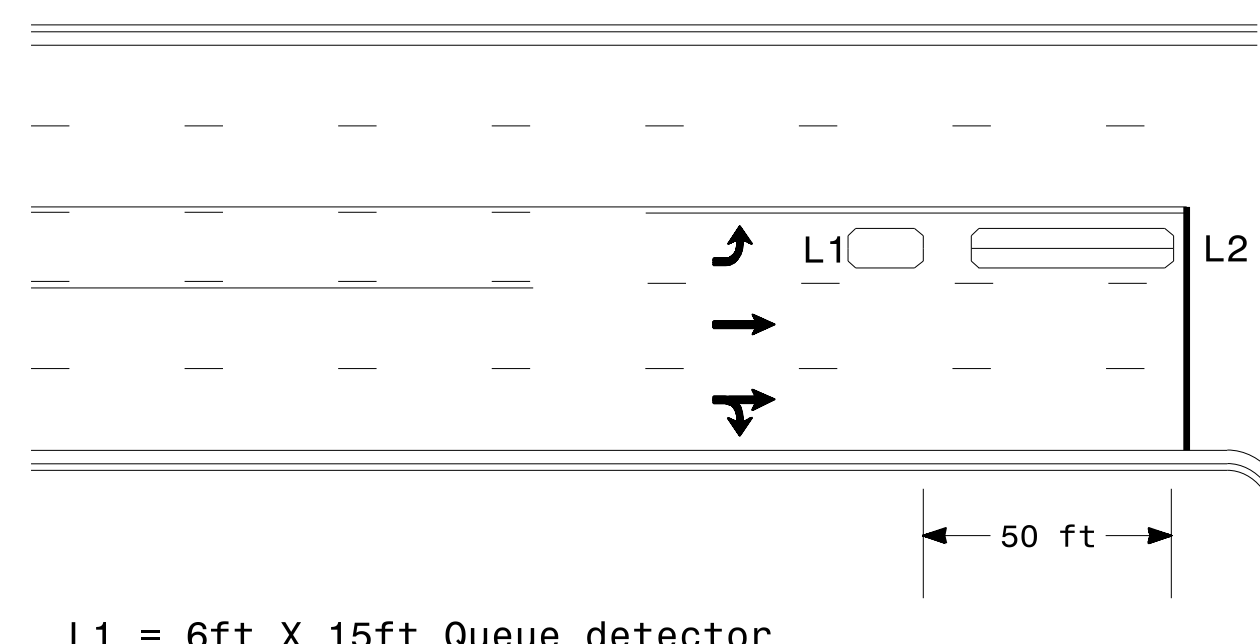

L1 = 6ft X 15ft Queue detector  
L2 = 6ft X 40ft Quadrupole loop

Queue Loop Detection

### Right Turn Lane Detection

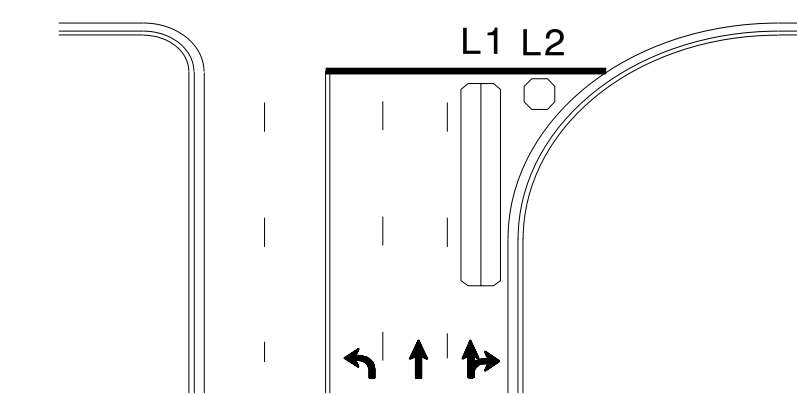

Shared Lane/  
Wide Radius Turn

L1 = 6ft X 40ft Quadrupole loop  
L2 = 6ft X 6ft [Minimum] Presence loop  
Wired separately

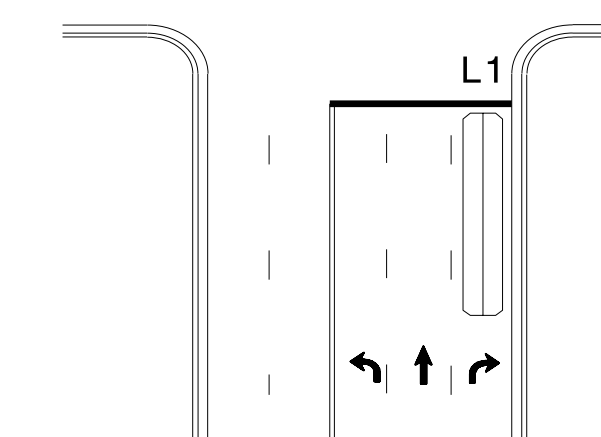

Standard Turn

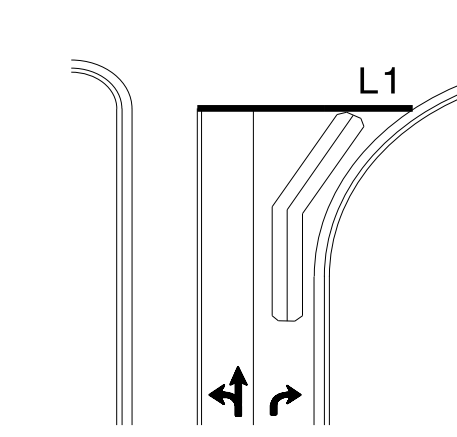

Wide Radius Turn

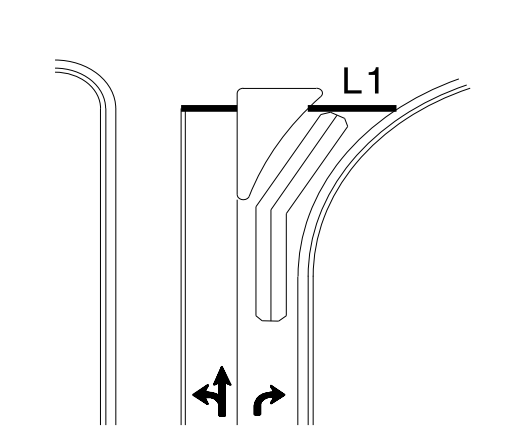

Channelized Turn

### Side Street Detection

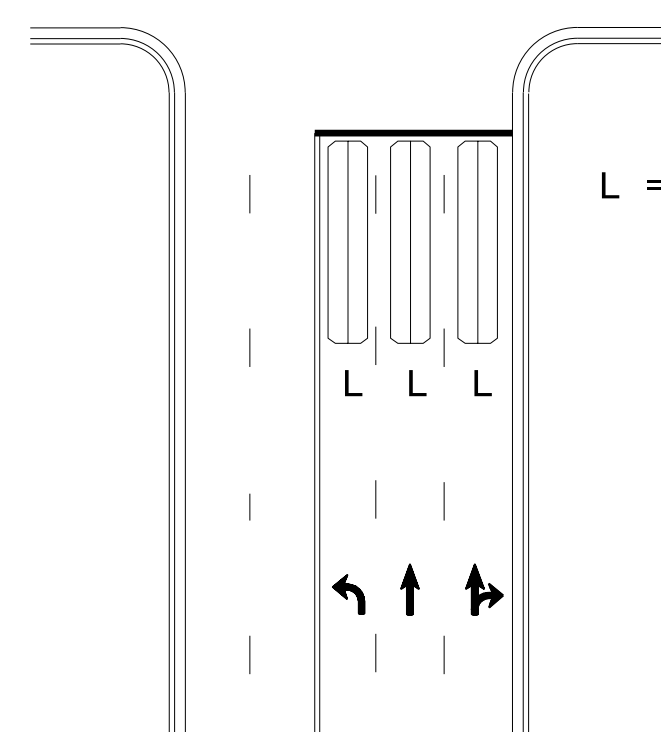

L = 6ft X 40ft  
Quadrupole loop  
Wired to separate  
detectors/channels

### Presence Loop Placement at Stop Lines

Locate loop slightly  
behind leading  
edge of stop line

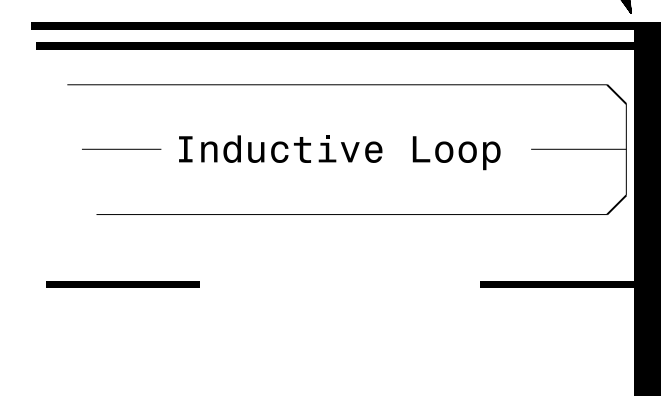

Note:

- Loop may be located in advance of stop line under any of the following conditions:
- 1) stop line is greater than 15' from edge of intersecting roadway
  - 2) loop detects a permissive or protected/permissive left turn
  - 3) for an exclusive right turn lane

### Recommended Number of Turns

Single 6' X 6' loop  
(when wired separately):

Length of Lead-in ft	Number of Turns
< 250	3
250-375	4
375-525	5
> 525	6

Quadrupole loops: Use 2-4-2 turns

6' X 15' Loops:

- Lead-in < 150', use 2 turns
- Lead-in > 150', use 3 turns

750 N. Greenfield Pkwy, Garner, NC 27529

#### Typical Signal Loop Locations

PLAN DATE: January 2015	REVIEWED BY: JPG
PREPARED BY: PLA	REVIEWED BY:
REVISIONS	INIT. DATE

SCALE: N/A

SEAL

1/30/2015