

Note:
 1. Opening in pole base plate shall be equal to pole base inside diameter minus 3 1/2" but shall not be less than 8 1/2".

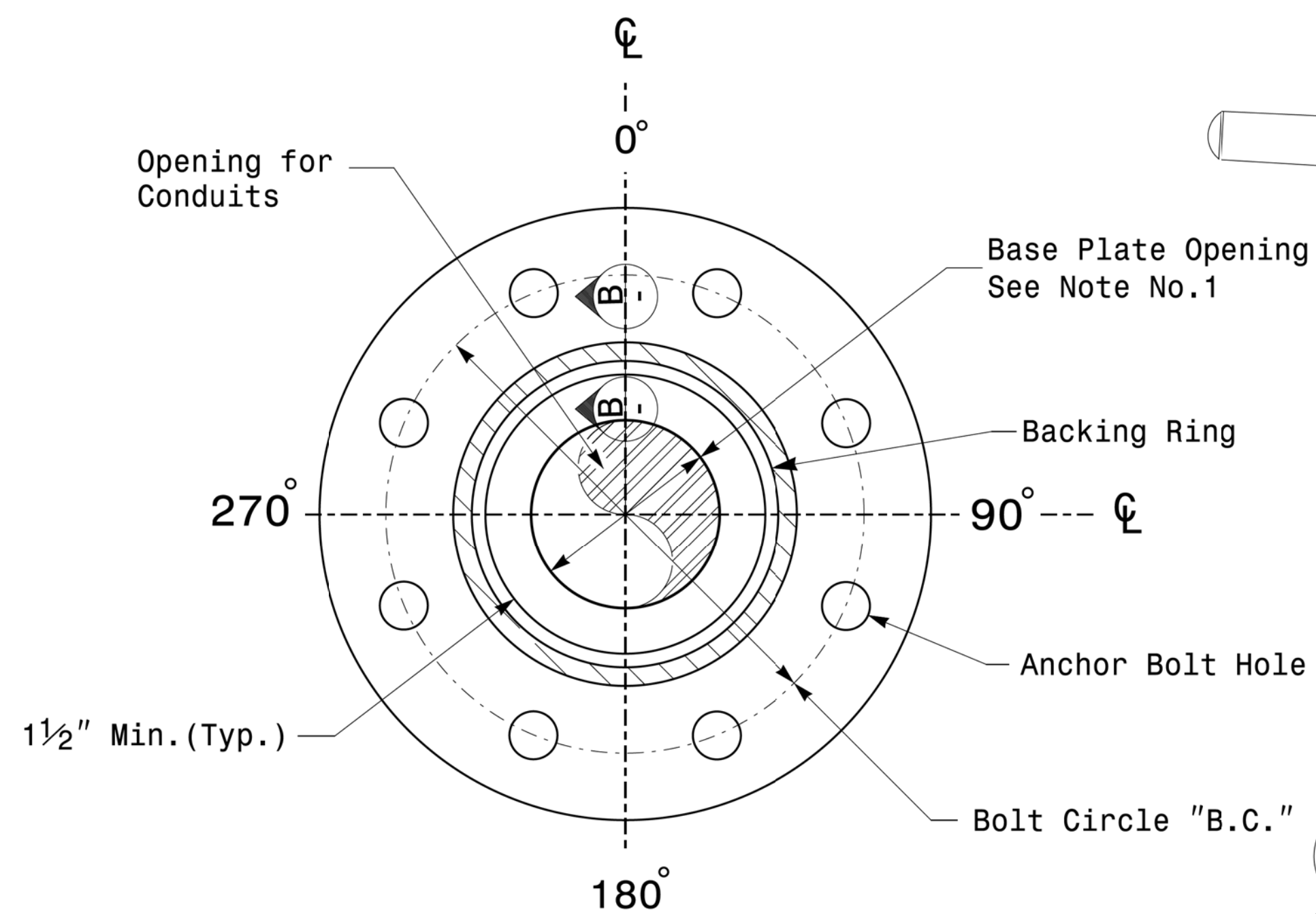

Section A-A
Pole Base Plate Details

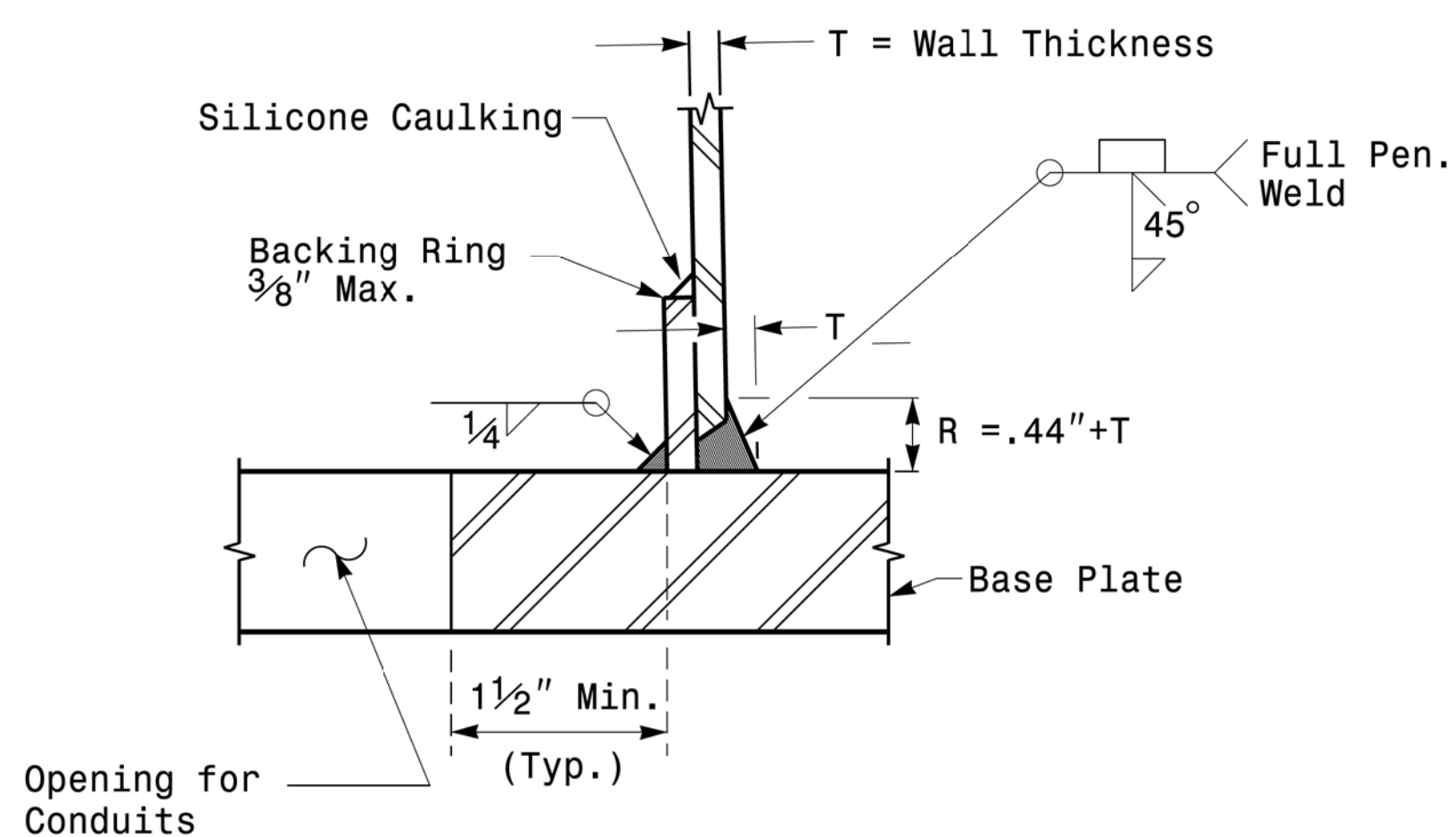

Section B-B
 (Pole Attachment to Base Plate)
Full-Penetration Groove Weld Detail

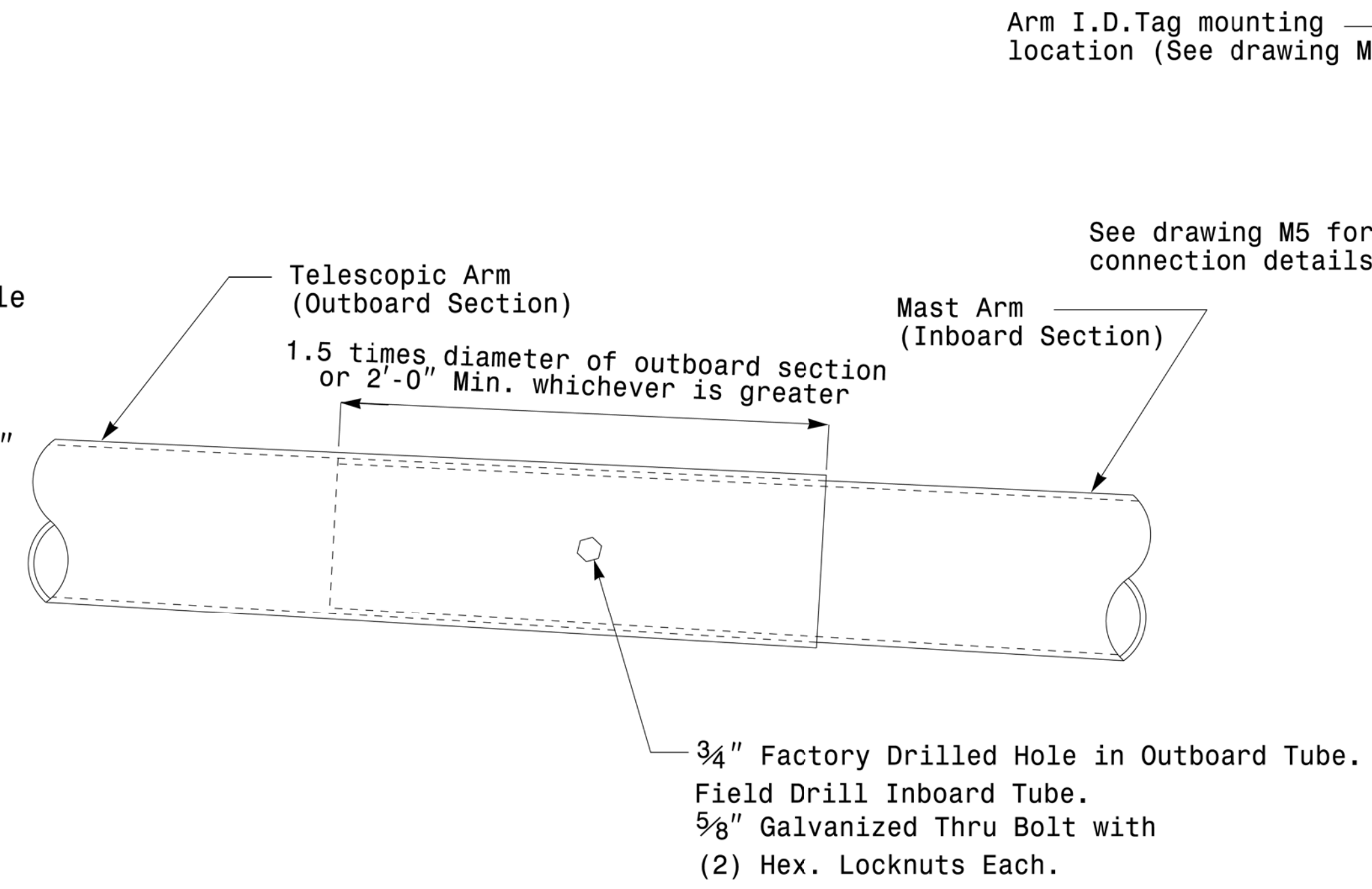
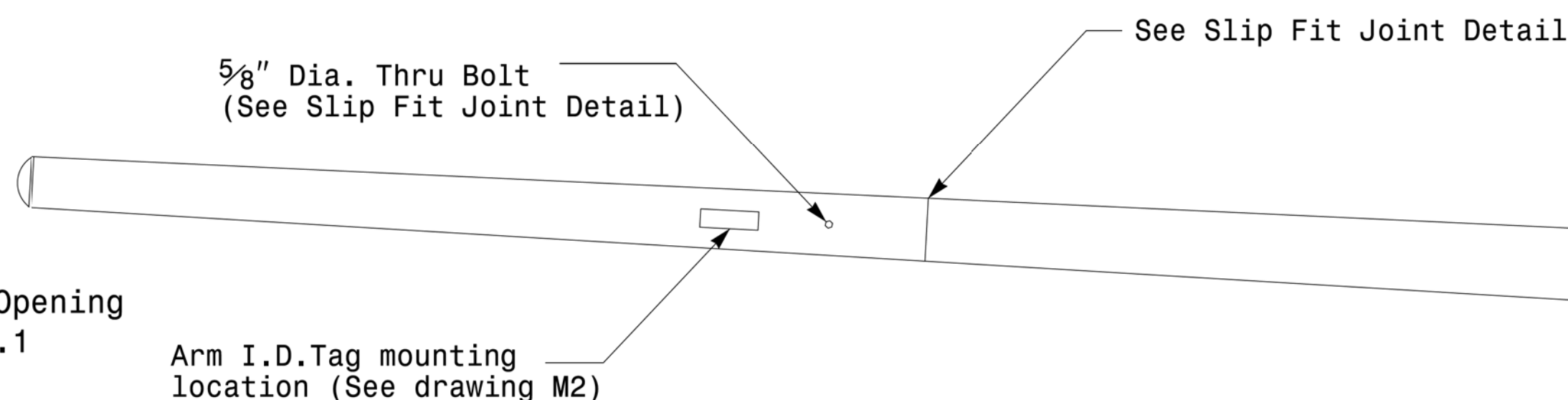

Slip Fit Joint Detail for Mast Arm

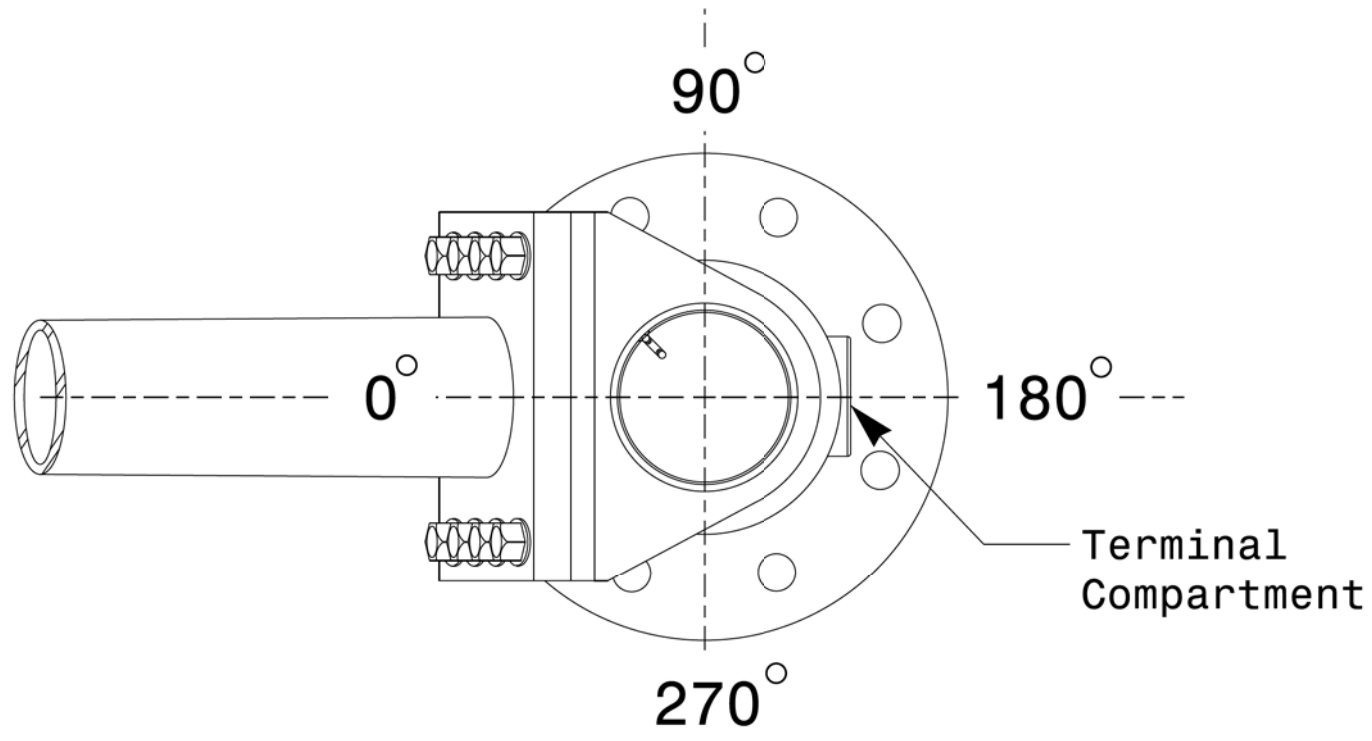

Mast Arm Radial Orientation

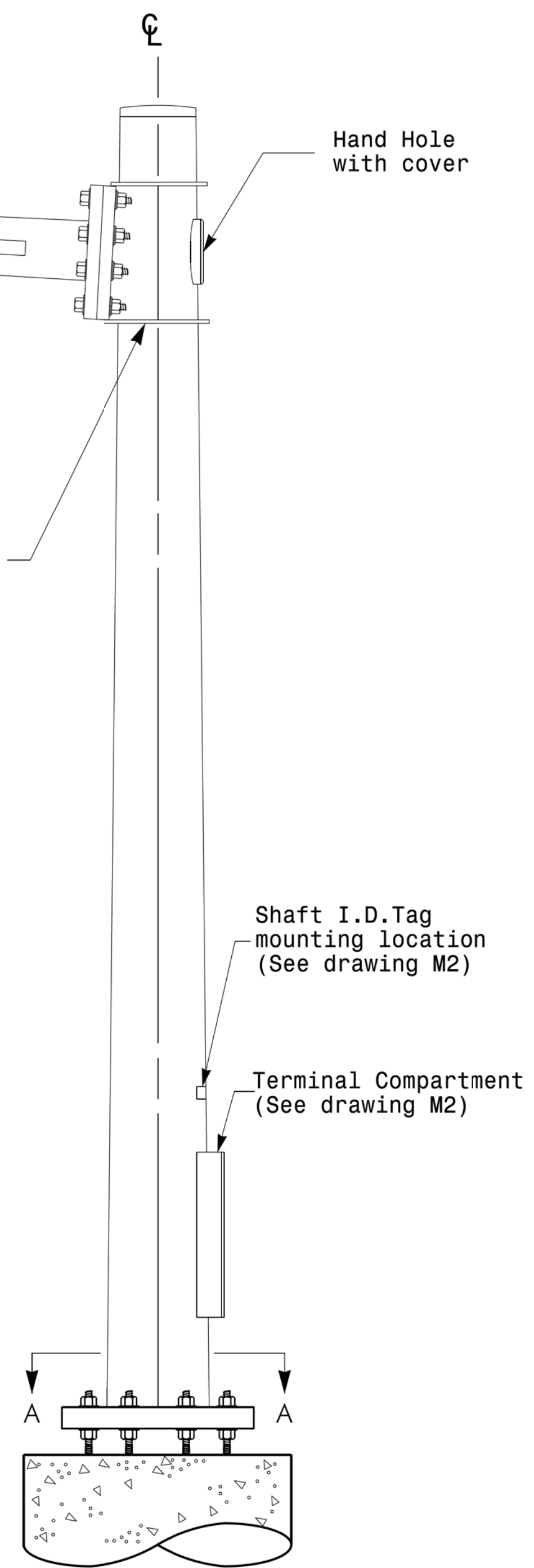

Mast Arm Pole

Fabrication Details - Mast Arm Poles

	Typical Fabrication Details For Mast Arm Poles		SEAL
	PLAN DATE: OCTOBER 2017 PREPARED BY: N. BITTING	DESIGNED BY: K.C. DURIGON REVIEWED BY: D.C. SARKAR	
SCALE: 0 NA NONE	REVISIONS:	INIT.:	DATE:
DocuSigned by: Dinesh C. Sarkar			10/11/2017 DATE

11-OCT-2017 08:33
 S:\413650\MTS Signal\sig1 Design Section\Eastern Region\MTS Sheets\2016\2014 Sig.M4 Std. Fabrication Detail\Mast Arm Poles.dgn
 User: dcahar