

DETAIL "T"

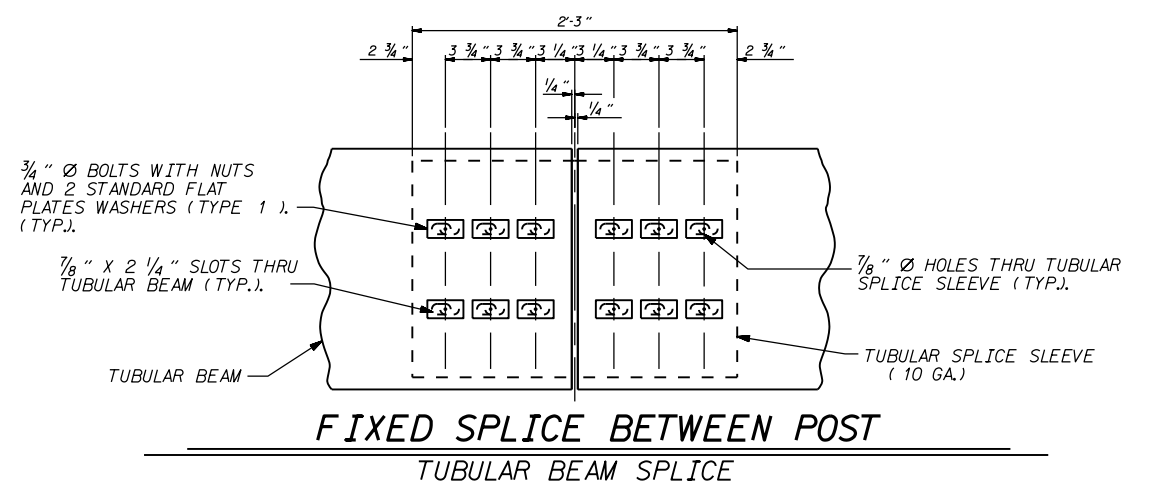

**FIXED SPLICE BETWEEN POST
TUBULAR BEAM SPLICE**

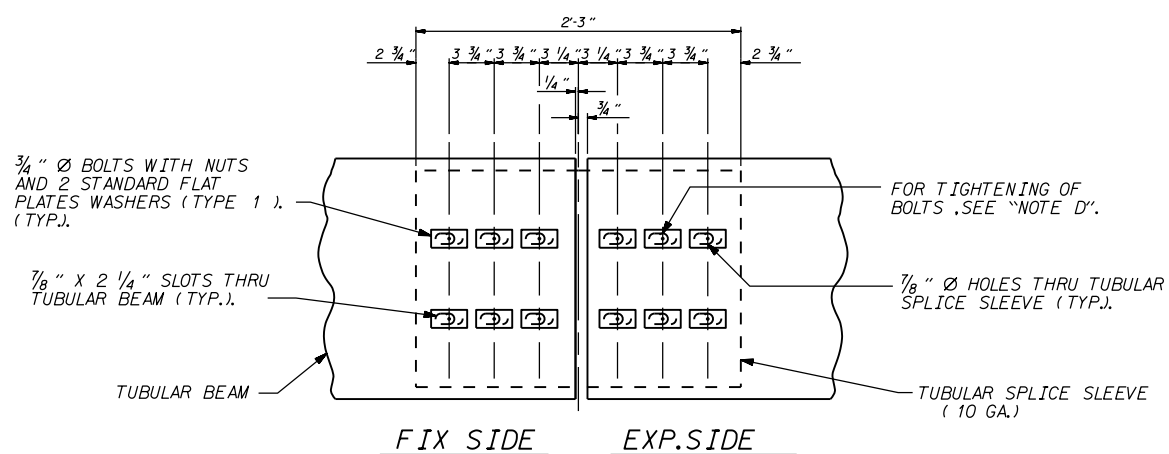

**EXPANSION SPLICE BETWEEN POST (TYPE 1)
TUBULAR BEAM SPLICE**

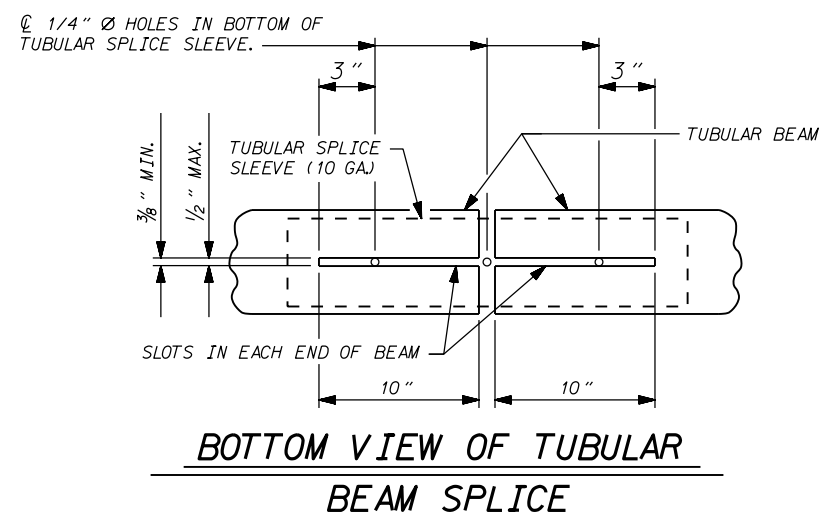

**BOTTOM VIEW OF TUBULAR
BEAM SPLICE**

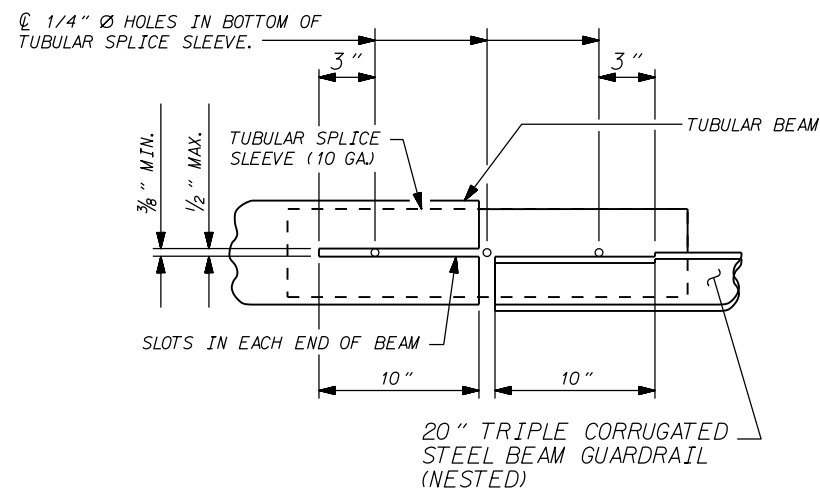

**BOTTOM VIEW OF TUBULAR AND
20\"/>TRIPLE CORRUGATED STEEL BEAM SPLICE**

LEGEND

- "A" -- USE W-TR GUARDRAIL TRANSITIONAL SECTION
- "B" -- USE STANDARD GUARDRAIL
- "C" -- USE 20\"/>TRIPLE CORRUGATED STEEL BEAM GUARDRAIL

TABLE 2

FLAT PLATE WASHER DIMENSIONS

TYPE	DESCRIPTION	A	B
1	STANDARD WASHER	3"	1 1/2"

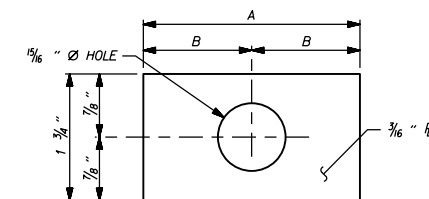

FLAT PLATE WASHER - TYPE 6

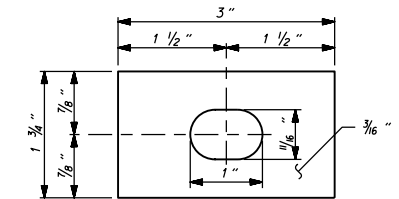

"NOTE D": BOLTS ON EXPANSION SIDE OF TUBULAR BEAM SPLICE SHALL BE TIGHTENED FINGER TIGHT. DOUBLE NUTS SHALL BE USED AND TIGHTENED AGAINST EACH OTHER TO PREVENT THE NUTS FROM BECOMING LOOSE ON THE BOLT.

CONTRACT STANDARDS AND DEVELOPMENT UNIT
 Office 919-707-6950 FAX 919-250-4119

RETROFIT OF EXISTING BRIDGE RAIL WITH TUBULAR BEAM GUARDRAIL

ORIGINAL BY: C.O. CUEVAS DATE: 9-1-98
 MODIFIED BY: DATE:
 CHECKED BY: DATE:
 FILE SPEC.: ds182:\usr\cesar\english\retrofit.dgn