

BEAM REPAIR

REPLACEMENT CUT-TO-FIT BEAM SECTION SHALL BE NEW AND FROM SIMILAR SIZE ROLLED BEAM OR APPROVED EQUIVALENT PLATES. THE GRADE OF STEEL SHALL BE AASHTO M270, GRADE 36 OR BETTER. AS DETERMINED BY THE ENGINEER, AREAS WITH EXCESSIVE SECTION LOSS OR AREAS WITH TEMPORARY REPAIRS SHALL BE REMOVED AND THE BEAMS SHALL BE REPAIRED AS INDICATED ON THIS PLAN SHEET. ENGINEER TO DETERMINE ACTUAL DIMENSIONS OF AREA TO BE REMOVED AND REPLACED. REMOVE CONCRETE BENT DIAPHRAGMS AS NEEDED TO EVALUATE LIMITS OF REPAIR.

PAYMENT FOR THE SECTION REPAIR SHALL BE BASED ON THE AMOUNT OF STEEL INCORPORATED IN THE FINISHED AND ACCEPTED REPAIR. GOUGES AND INDENTIONS FROM IMPACT ON GIRDERS SHALL BE GROUND SMOOTH PRIOR TO BLASTING AND PAINTING OPERATION.

FOR MAINTENANCE OF TRAFFIC, SEE TRAFFIC MANAGEMENT PLANS.

FOR BEAM REPAIR, SEE SPECIAL PROVISIONS.

FOR UNDER STRUCTURE WORK PLATFORM, SEE SPECIAL PROVISIONS.

FOR CONCRETE DIAPHRAGM REPAIR, SEE SPECIAL PROVISIONS.

REPAIR SEQUENCE:

REMOVE LIVE LOAD FROM REPAIR AREA BY EITHER CLOSING BRIDGE TO TRAFFIC OR SHIFTING TRAFFIC AWAY FROM REPAIR AREA.

REMOVE DEAD LOAD FROM BEAM BY JACKING AND BLOCKING. CONTRACTOR SHALL SUBMIT JACKING PLAN FOR APPROVAL, PRIOR TO BEGINNING WORK. FOR BRIDGE JACKING, SEE SPECIAL PROVISIONS.

STEEL DIAPHRAGM CHANNELS AND/OR STIFFENERS MAY BE TEMPORARILY REMOVED, IF NECESSARY, AND RESET AFTER BEAM REPAIR.

IF BEAM DETERIORATION EXTENDS INTO THE CONCRETE DIAPHRAGM THEN CHIP AWAY CONCRETE TO DETERMINE THE EXTENT OF THE DAMAGE. CUT OUT BY APPROPRIATE MEANS THE DAMAGED BEAM AREA AND/OR BEARING STIFFENER.

FOR LEAD BASED PAINT SYSTEMS, REMOVE A 3" WIDE STRIP AT THE CUT LINES.

INSTALL THE CUT-TO-FIT SECTION, FULLY WELD ALONG TOP AND SIDES OF PLATE USING FULL PENETRATION WELDS.

ALL WELDING SHALL BE IN ACCORDANCE WITH CURRENT APPLICABLE AWS AND NCDOT STANDARD SPECIFICATIONS.

ALL WELDS WILL BE INSPECTED AND TESTED BY THE NCDOT MATERIALS AND TEST UNIT IN ACCORDANCE WITH THE CURRENT AWS BRIDGE WELDING CODE AND STANDARD SPECIFICATIONS.

IN ACCORDANCE WITH THE STANDARD SPECIFICATIONS, AFTER REPAIR, GRIND ALL WELDS FLUSH, THOROUGHLY CLEAN AREA TO REMOVE DEBRIS AND OILS FROM REPAIR PROCESS.

CLEANING AND PAINTING OF REPAIRED STRUCTURAL STEEL SHALL BE PERFORMED AS PART OF THE OVERALL CLEANING AND PAINTING CONTRACT.

FOR CLEANING AND PAINTING, SEE PAINTING EXISTING STRUCTURE SPECIAL PROVISIONS.

AFTER BEAMS ARE REPAIRED AND PAINTED, ANY CONCRETE REMOVED FROM THE BENT DIAPHRAGMS SHALL BE CAST BACK. ANY REINFORCING STEEL CUT DURING THE REMOVAL PROCESS SHALL BE SPLICED WITH A SIMILAR SIZE BAR WITH AT LEAST A ONE FOOT SPLICE TO THE EXISTING STEEL. FOR BEAM REPAIR, SEE SPECIAL PROVISIONS.

LOWER SPAN TO BEAR; CHECK FOR DISTRESS.

REMOVE JACKING EQUIPMENT AND TEMPORARY SUPPORTS.

REMOVE ALL TRAFFIC CONTROL DEVICES.

PROJECT NO. I-5889A
BUNCOMBE COUNTY
 BRIDGE NO. 378

STATE OF NORTH CAROLINA
 DEPARTMENT OF TRANSPORTATION
 RALEIGH

**BEAMS 1 & 6
 BEAM END
 REPAIR DETAILS**

REVISIONS						SHEET NO.
NO.	BY:	DATE:	NO.	BY:	DATE:	S-193
1			3			TOTAL SHEETS
2			4			208



PLANS PREPARED BY:
Gannett Fleming
 Excellence Delivered As Promised

2610 Wycliff Road
 Suite 102
 Raleigh, NC 27607-3073
 (919) 420-7660
 NC Lic. No. F-0270

DOCUMENT NOT CONSIDERED FINAL UNLESS ALL SIGNATURES COMPLETED

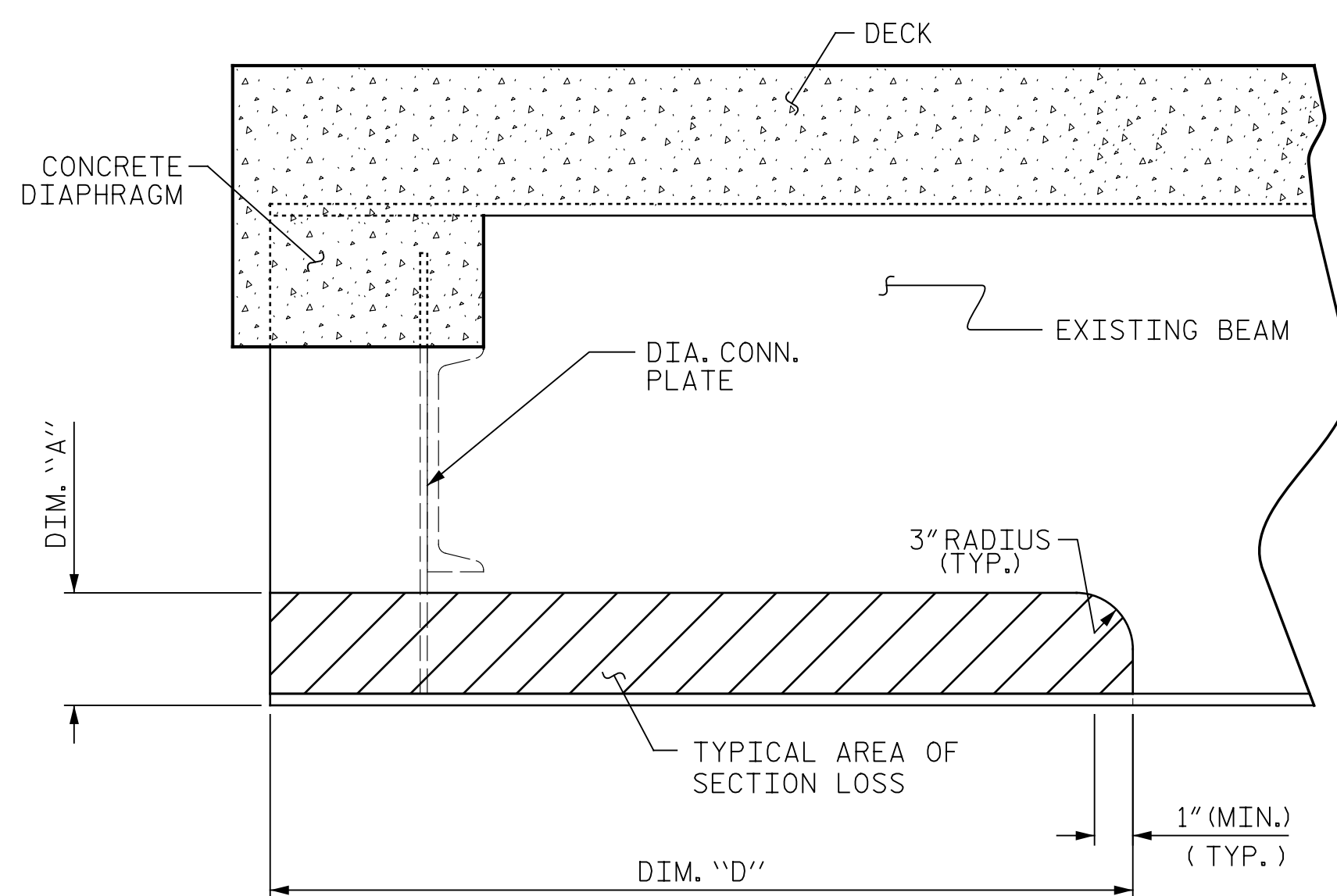

SECTION LOSS BEAM END REPAIR
 ("BE" REPAIR)

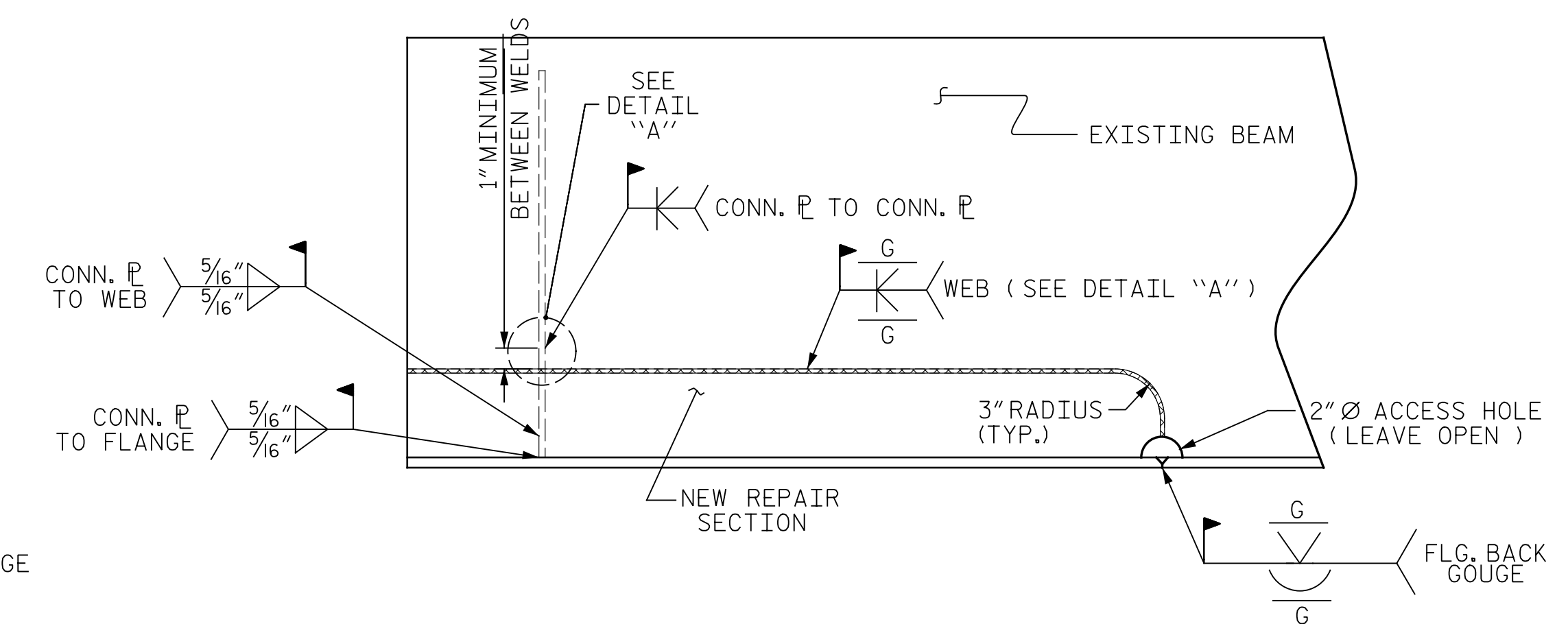

SECTION LOSS BEAM END REPAIR
 ("BE" REPAIR)

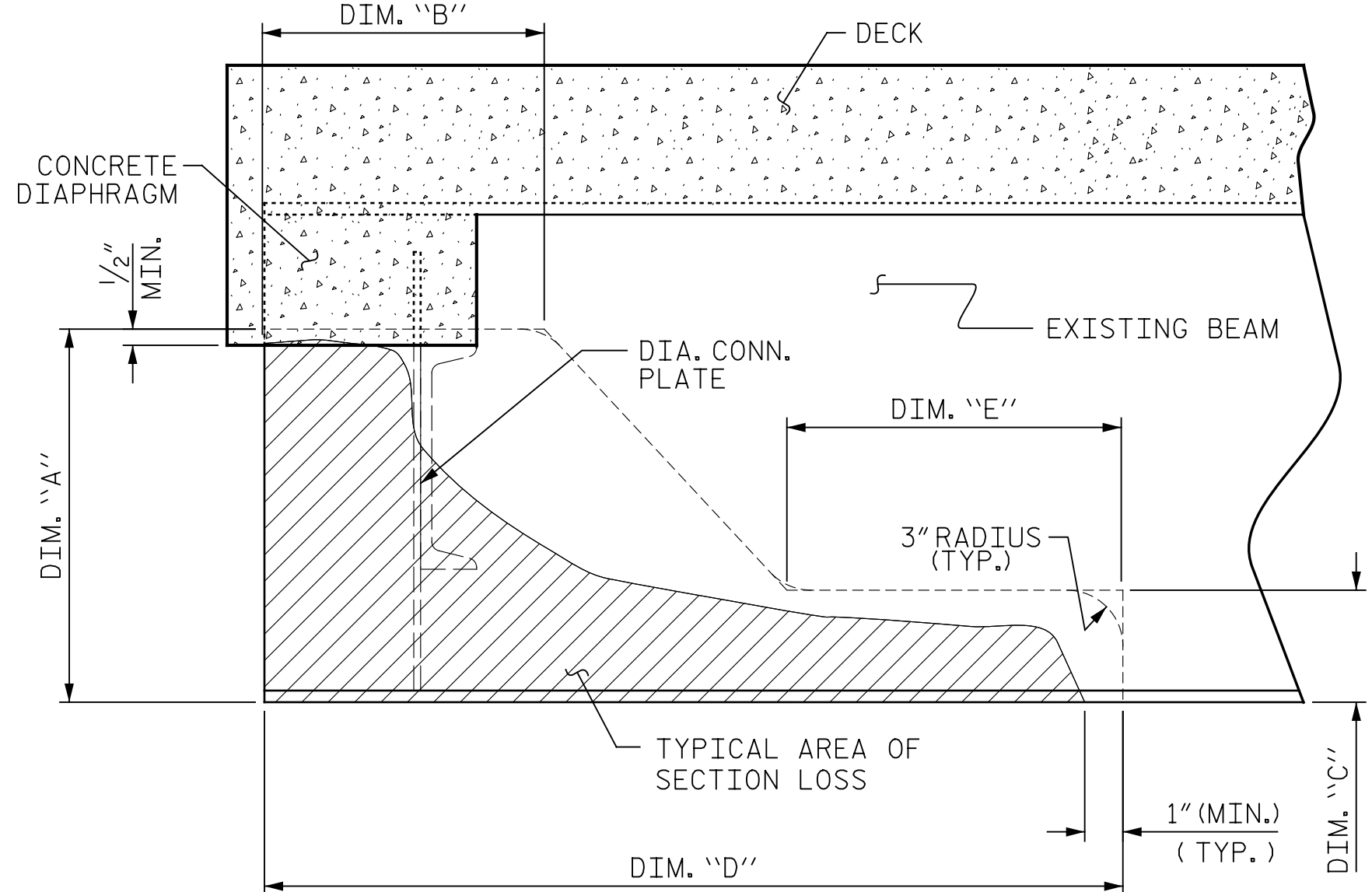

SECTION LOSS BEAM END REPAIR
 ("BE" REPAIR)

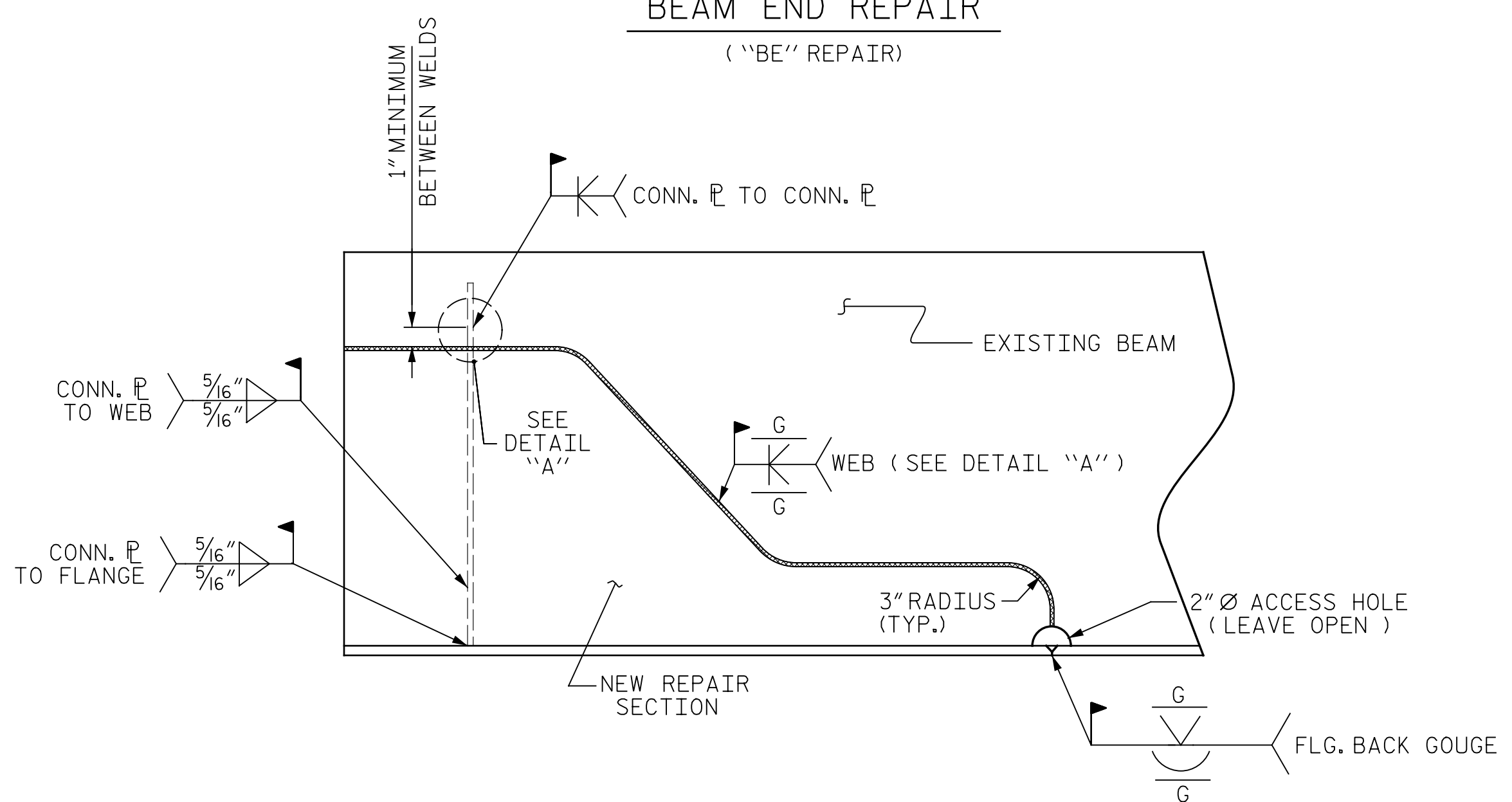

SECTION LOSS BEAM END REPAIR
 ("BE" REPAIR)

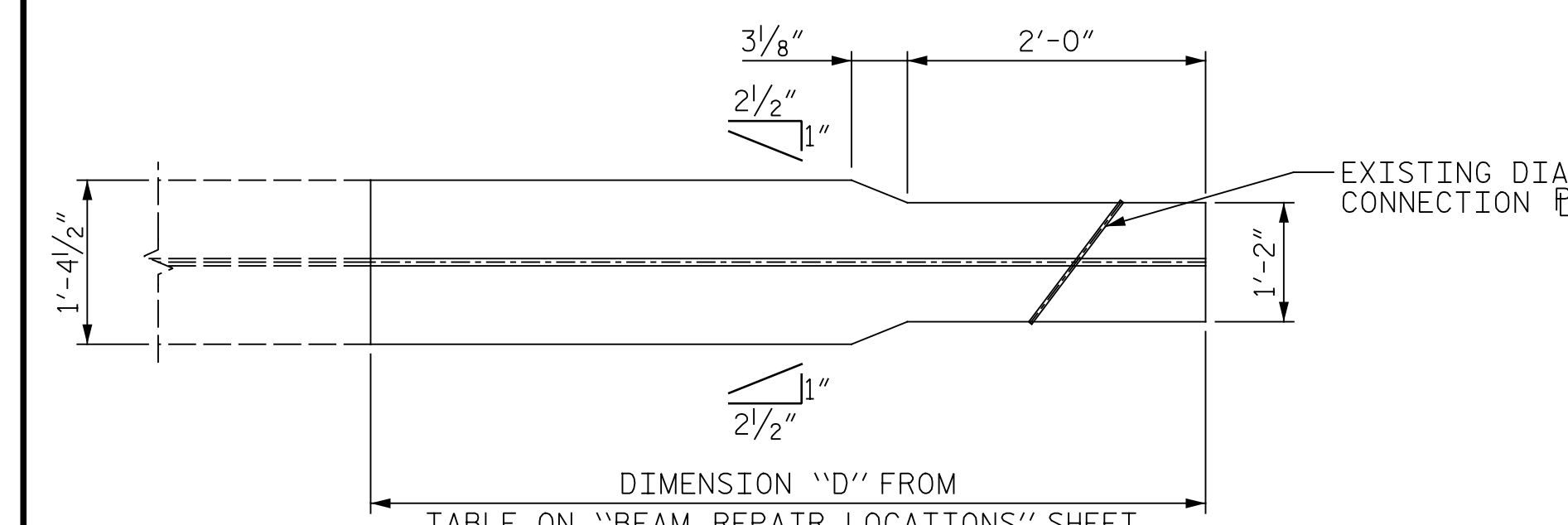

BEAM END DETAIL FOR BENT 1 SPAN A AND BENT 2 SPAN B
 BENT 1 SPAN B AND BENT 2 SPAN C ARE OPPOSITE HAND

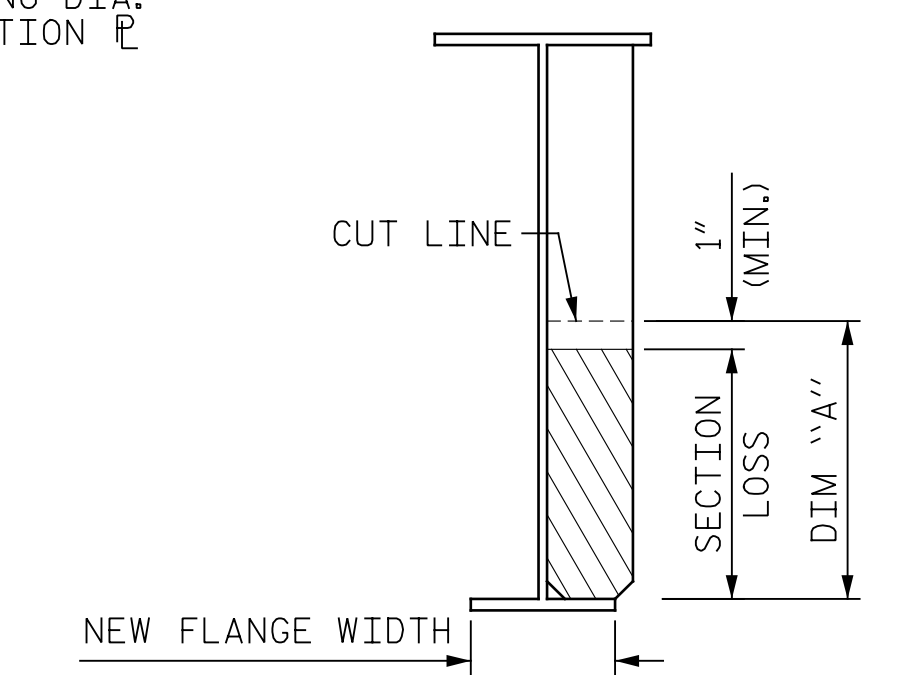

SECTION LOSS CONN. P REPAIR
 ("C" REPAIR)

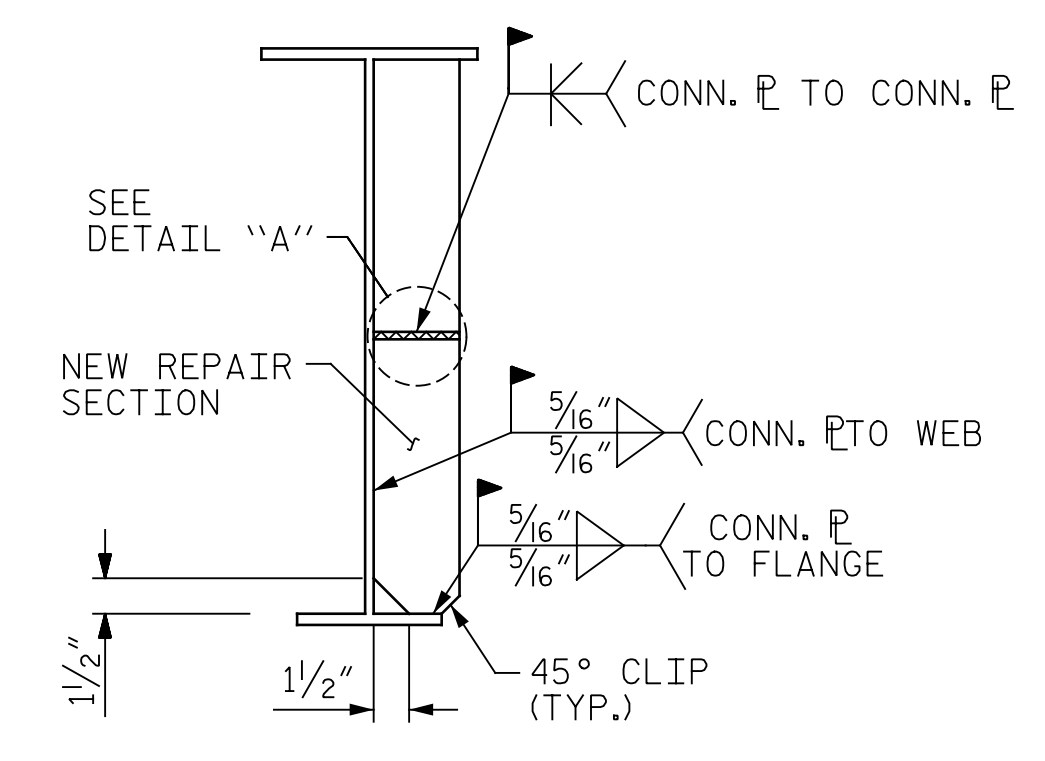

SECTION LOSS CONN. P REPAIR SECTION
 ("C" REPAIR)

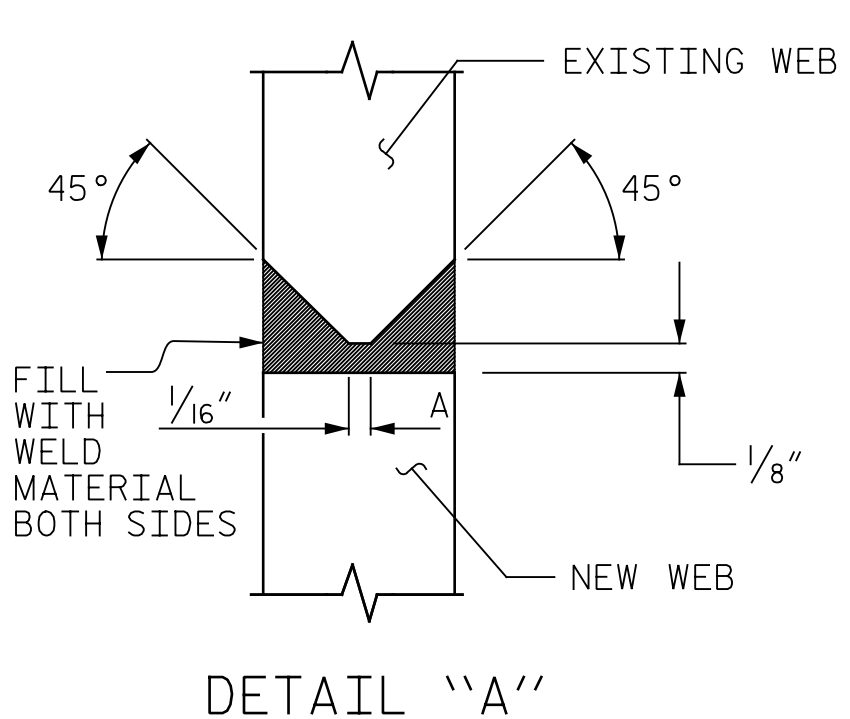

DETAIL "A"

DRAWN BY: M.A.LEE DATE: 10/2017
 CHECKED BY: R.NELSON DATE: 10/2017