

EXISTING

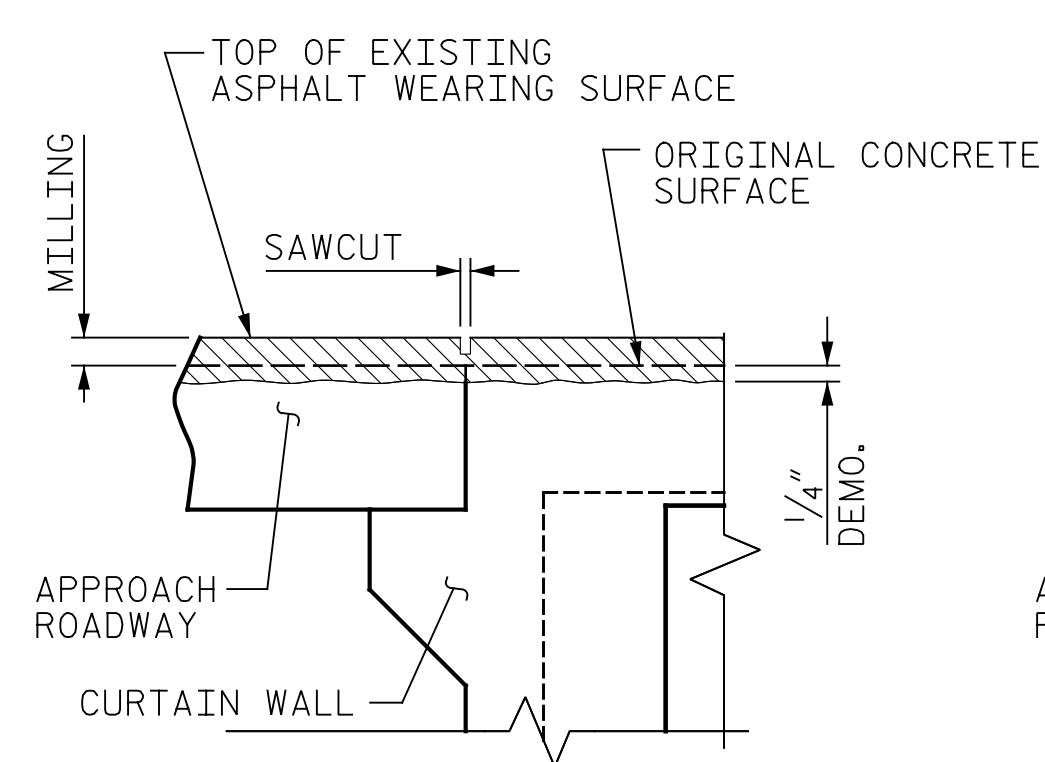

MINIMUM EXISTING JOINT DEMOLITION

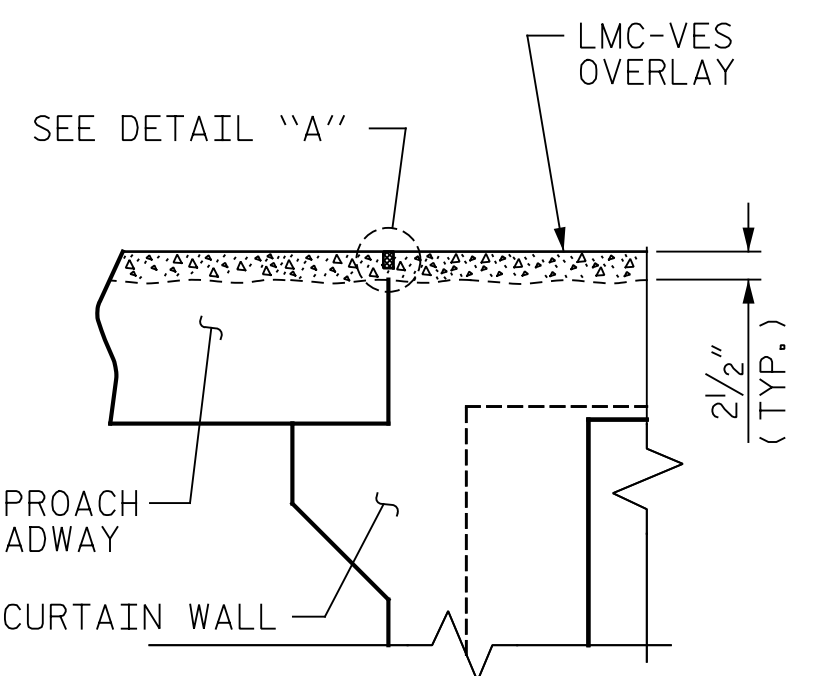

PROPOSED

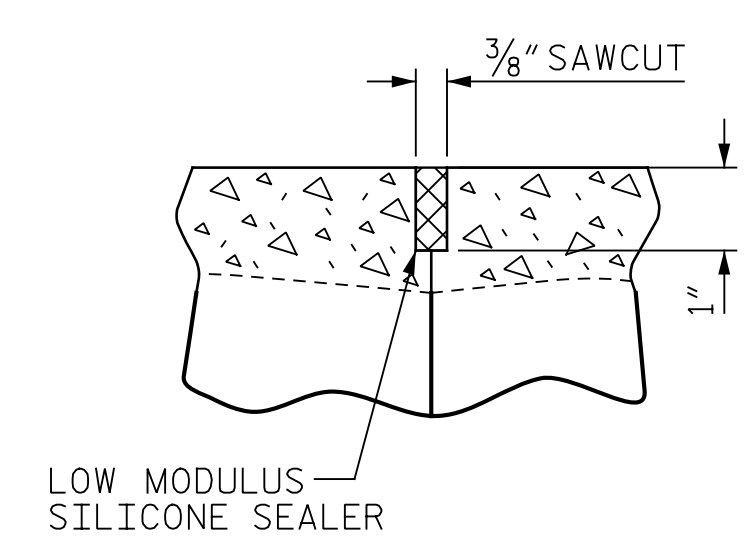

DETAIL "A"

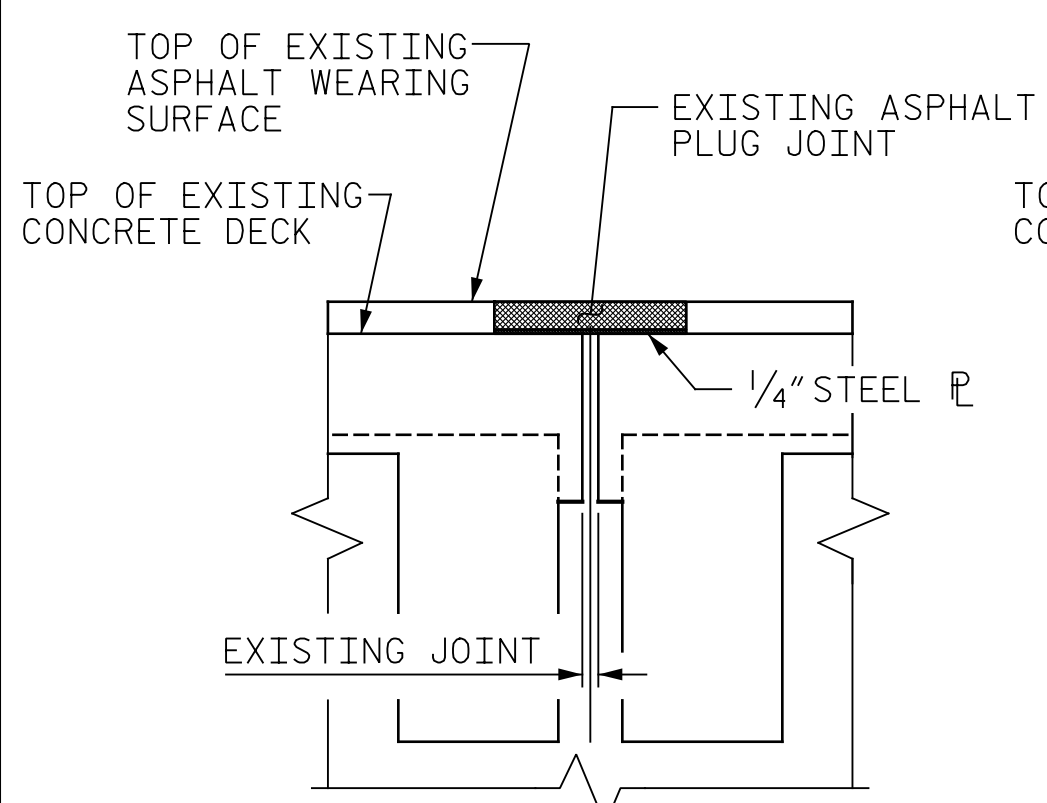

EXISTING JOINT

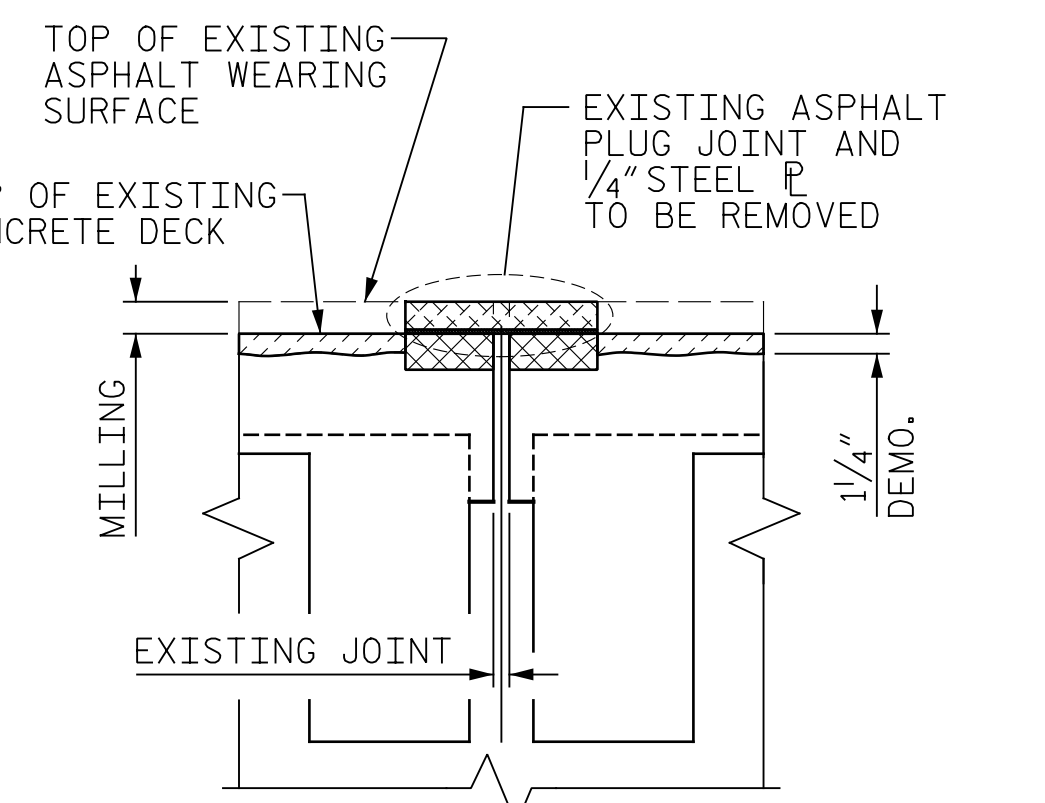

MINIMUM EXISTING JOINT DEMOLITION

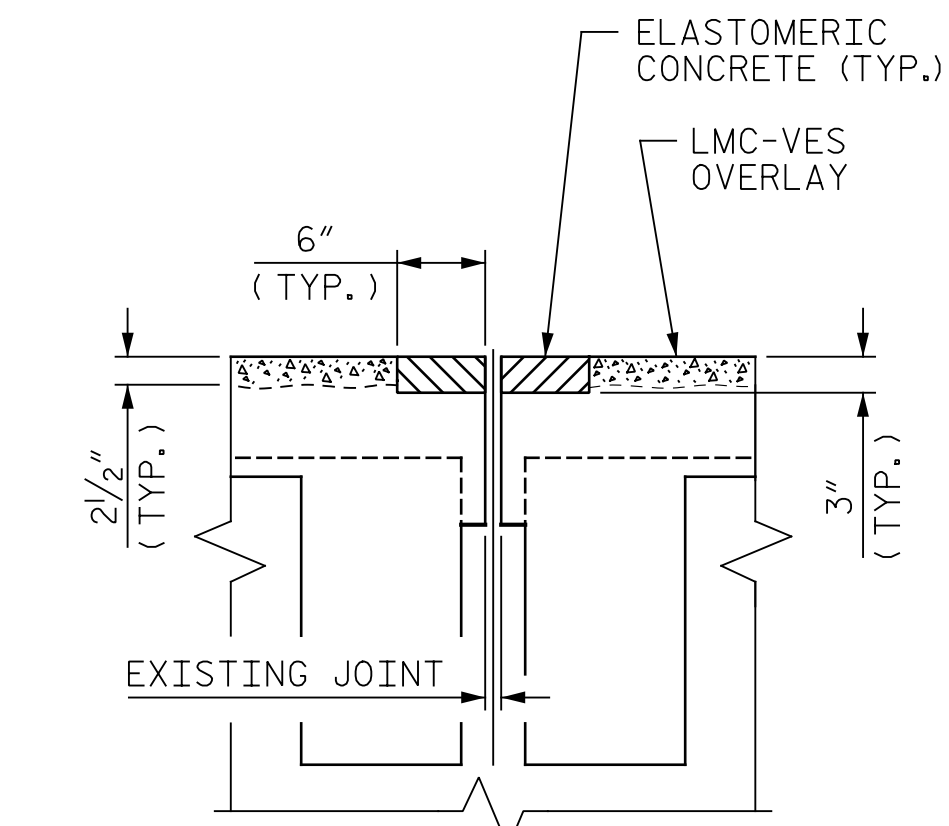

PROPOSED JOINT PRE-SAWED DIMENSIONS

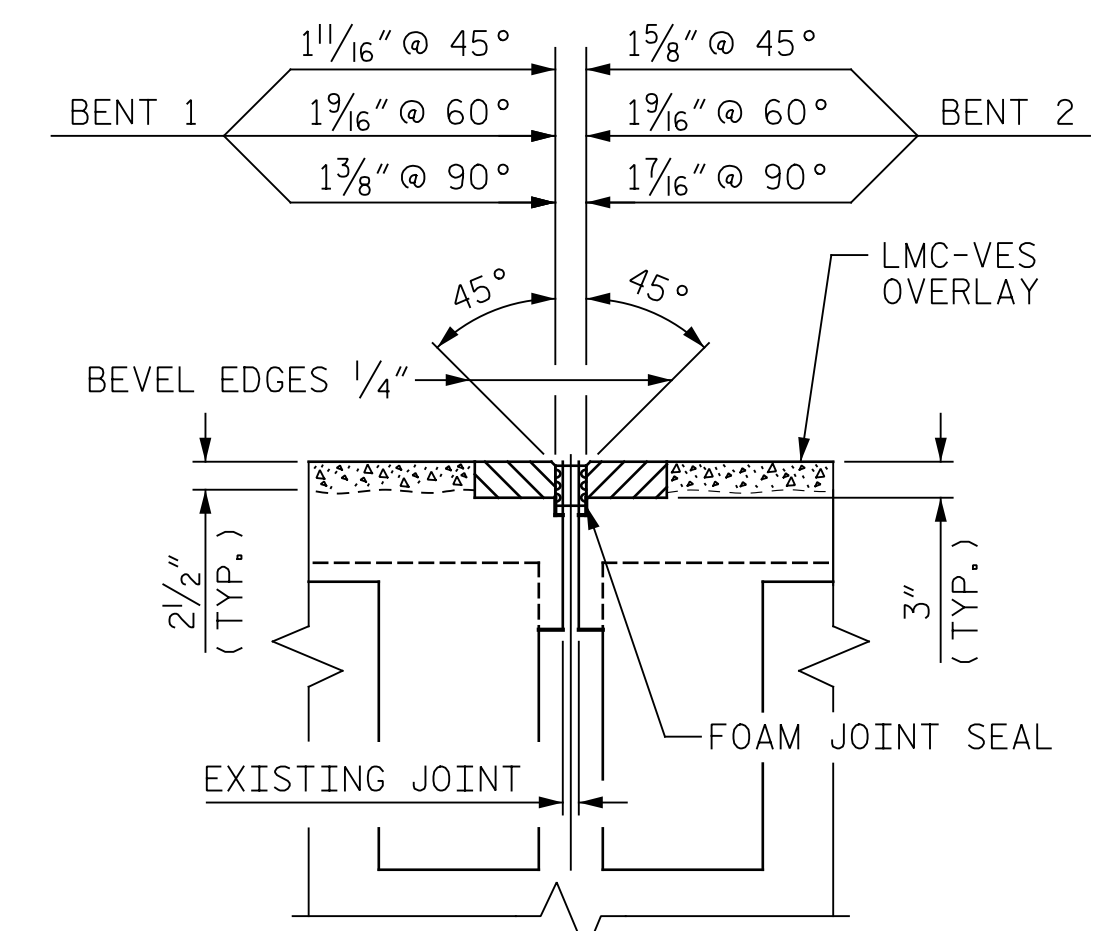

PROPOSED FOAM JOINT SEAL

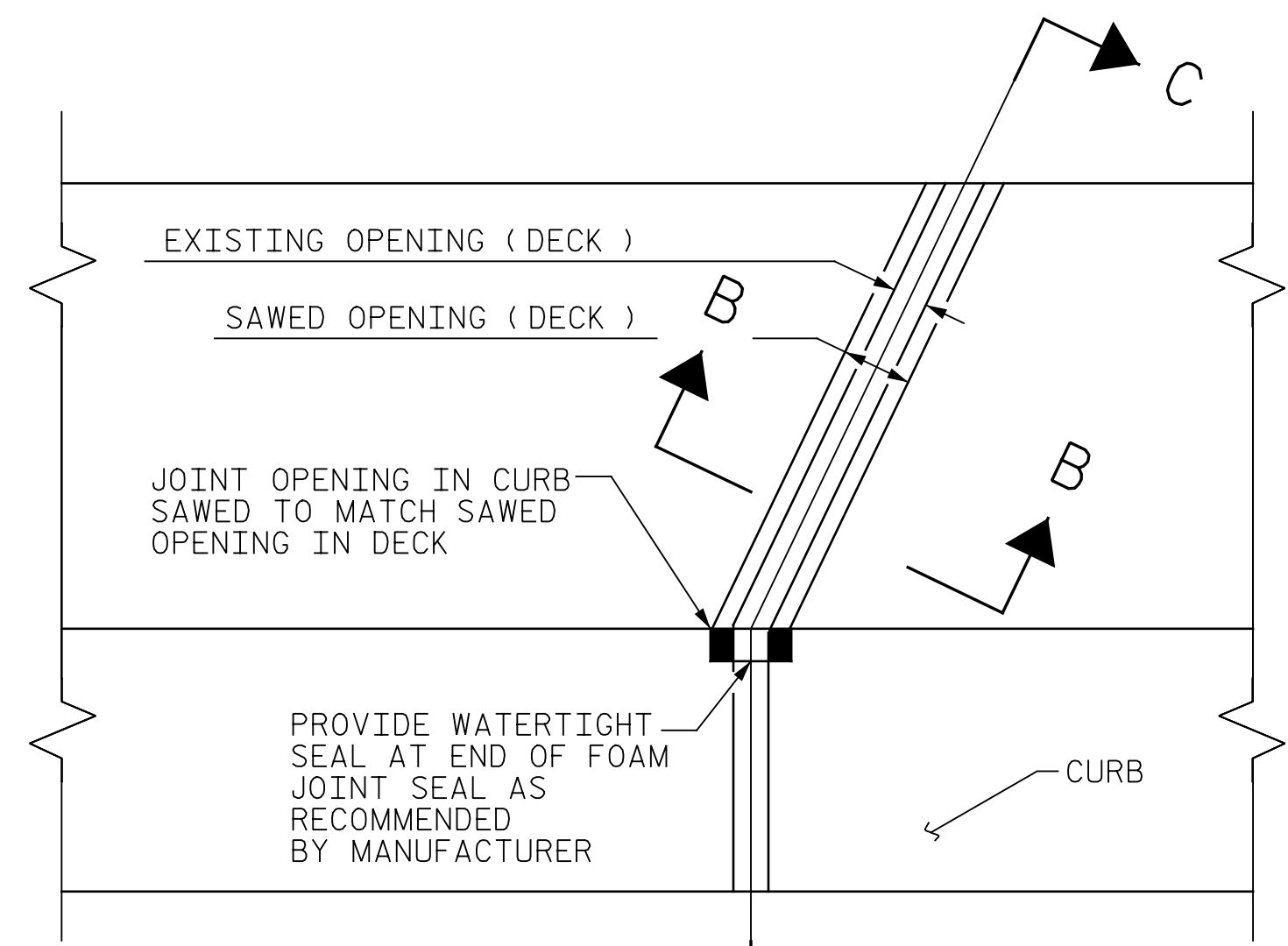

PLAN

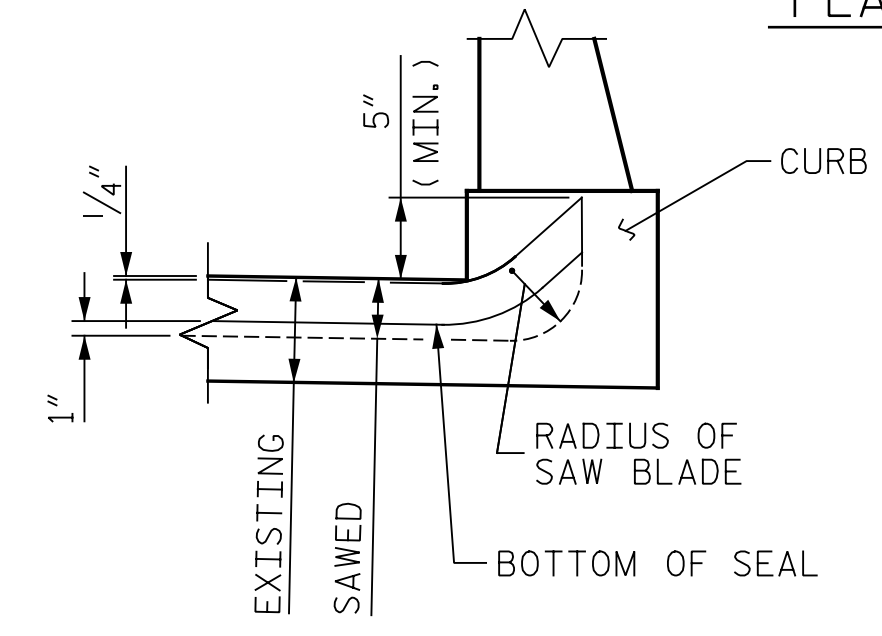

SECTION C-C

FOAM JOINT SEAL SHALL BE FACTORY FORMED OR CUT, HEAT WELDED AND TURNED UP PARALLEL TO FACE OF CURB.

NOTES:

- FOR FOAM JOINT SEALS SEE SPECIAL PROVISIONS.
- THE INSTALLED FOAM JOINT SEAL SHALL BE WATER TIGHT.
- NOMINAL UNCOMPRESSED SEAL WIDTH OF FOAM JOINT SEAL SHALL BE 2".
- THE CONTRACTOR WILL NOT BE PERMITTED TO FORM THE JOINTS IN LIEU OF SAWING THE JOINT.

IF THE EMBEDDED PORTION OF THE EXISTING PLASTIC WATERSTOP IS EXPOSED DURING REMOVAL OF UNSOUND CONCRETE OR IF UNSOUND CONCRETE IS REMOVED TO WITHIN 2" OF THE WATERSTOP, THE ENTIRE WATERSTOP SHALL BE REMOVED.

HYDRO-DEMOLITION OR EXCAVATION OF CONCRETE AT THE EXISTING JOINT SHALL RESULT IN THE BOTTOM OF THE EXCAVATION BEING REASONABLY FLAT AND LEVEL, TO PROVIDE SUFFICIENT SUBSTRATE FOR PLACEMENT AND SUPPORT OF ELASTOMERIC OR REPAIR CONCRETE. DEMOLISH BRIDGE JOINT TO THE NECESSARY DEPTH, SUCH THAT ELASTOMERIC CONCRETE SHALL BE FOUNDED ON CONCRETE OR REPAIR CONCRETE SUBSTRATE, NOT LATEX MODIFIED CONCRETE

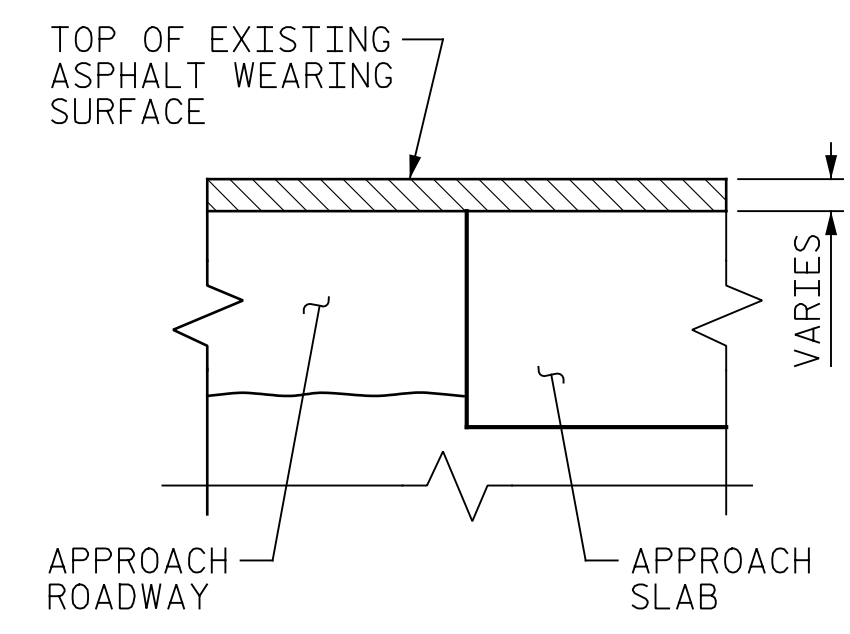

EXISTING

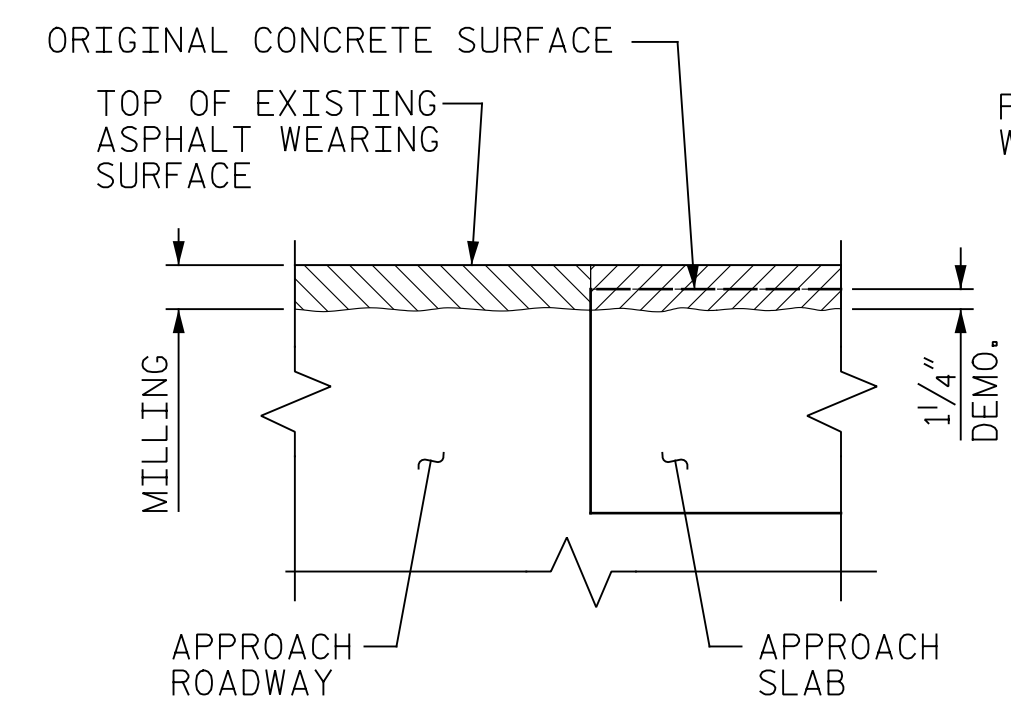

MINIMUM EXISTING JOINT DEMOLITION

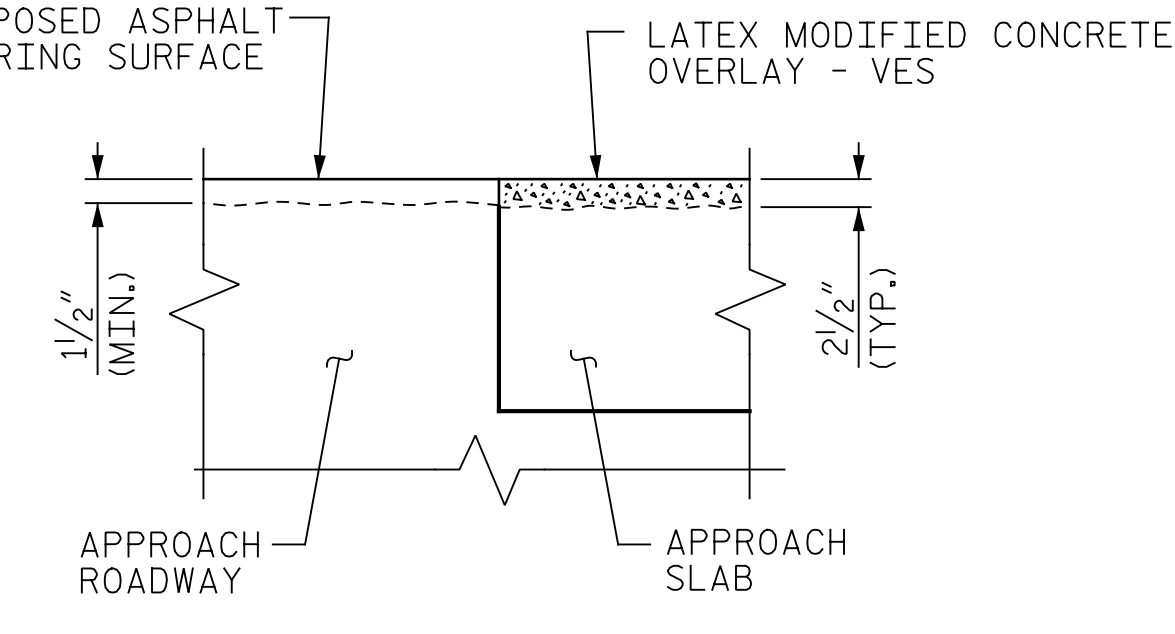

PROPOSED

SECTION D-D

PROJECT NO. I-5889A
BUNCOMBE COUNTY
 BRIDGE NO. 378

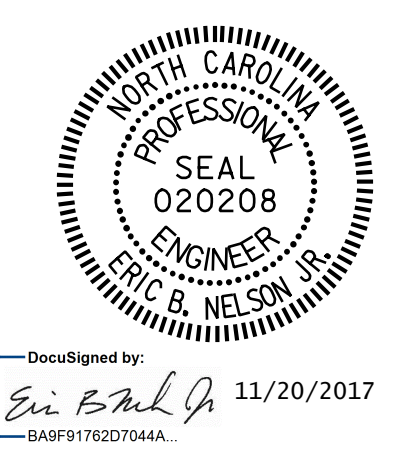

DocuSigned by:
 Eric B. Nelson
 11/20/2017

STATE OF NORTH CAROLINA
 DEPARTMENT OF TRANSPORTATION
 RALEIGH

JOINT DETAILS

REVISIONS					
NO.	BY:	DATE:	NO.	BY:	DATE:
1			3		
2			4		

SHEET NO. S-191
 TOTAL SHEETS 208

DRAWN BY: M.A.LEE DATE: 10/2017
 CHECKED BY: R.NELSON DATE: 10/2017

PLANS PREPARED BY:
Gannett Fleming
 Excellence Delivered As Promised

2610 Wycliff Road
 Suite 102
 Raleigh, NC 27607-3073
 (919) 420-7660
 NC Lic. No. F-0270

DOCUMENT NOT CONSIDERED FINAL UNLESS ALL SIGNATURES COMPLETED