

# AS-BUILT REPAIR QUANTITY TABLE

BENT 1 REPAIRS	QUANTITIES				
	ESTIMATE		ACTUAL		
SHOTCRETE REPAIRS	AREA SF	VOLUME CF	AREA SF	DEPTH FT	VOLUME CF
CAP (VERTICAL FACE)	2.3	1.1			
CAP (HORIZONTAL, CORNER)	0	0			
COLUMN	28.4	14.2			
EPOXY COATING		AREA SF			AREA SF
TOP OF CAP		79			

VALUES IN CHART REPRESENT ESTIMATED REPAIR TOTALS AFTER REMOVAL OF UNSOUND CONCRETE, MIN. OF 1" BEHIND REBAR AND MIN. 2" CL TO SAWCUT. SEE REPAIR DETAILS.



### NOTES:

REPAIR LOCATIONS AND ESTIMATE OF QUANTITIES ARE GIVEN WITH THE BEST INFORMATION AVAILABLE. IF ADDITIONAL REPAIRS NOT SHOWN ON THE DRAWINGS ARE DEEMED NECESSARY BY THE INSPECTOR OR ENGINEER THE CONTRACTOR SHALL NOTE ON THE DRAWINGS THE APPROXIMATE LOCATION AND DESCRIPTION OF THE REPAIRS AND ADJUST THE ACTUAL QUANTITIES ENTERED INTO THE REPAIR QUANTITY TABLE.

SHOTCRETE REPAIRS MAY BE REPLACED WITH CONCRETE REPAIRS WITH THE APPROVAL OF THE ENGINEER.

FOR SHOTCRETE REPAIRS, SEE SPECIAL PROVISIONS.

FOR CONCRETE REPAIR DETAILS, SEE "TYPICAL CAP & COLUMN REPAIR DETAILS" SHEET.

-  - SHOTCRETE REPAIR
-  - CONCRETE REPAIR

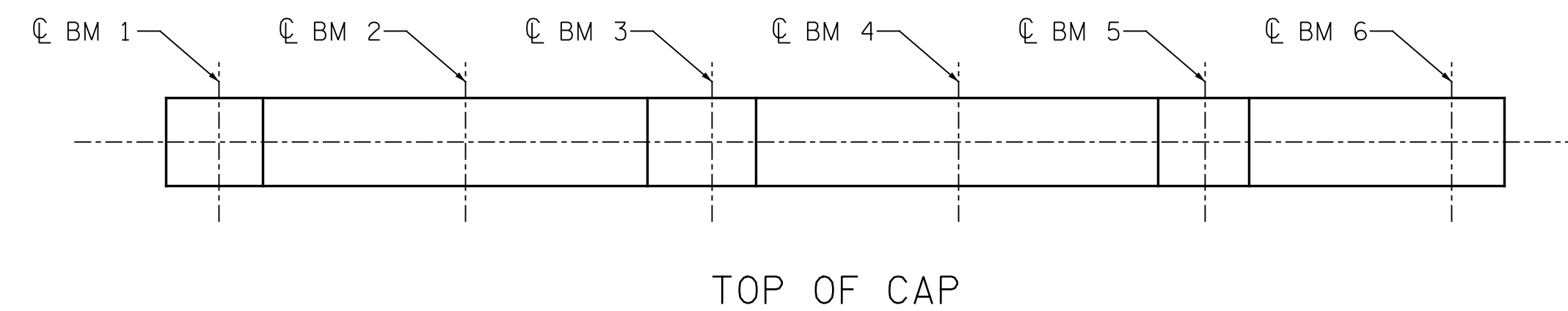

SPAN B

SPAN A

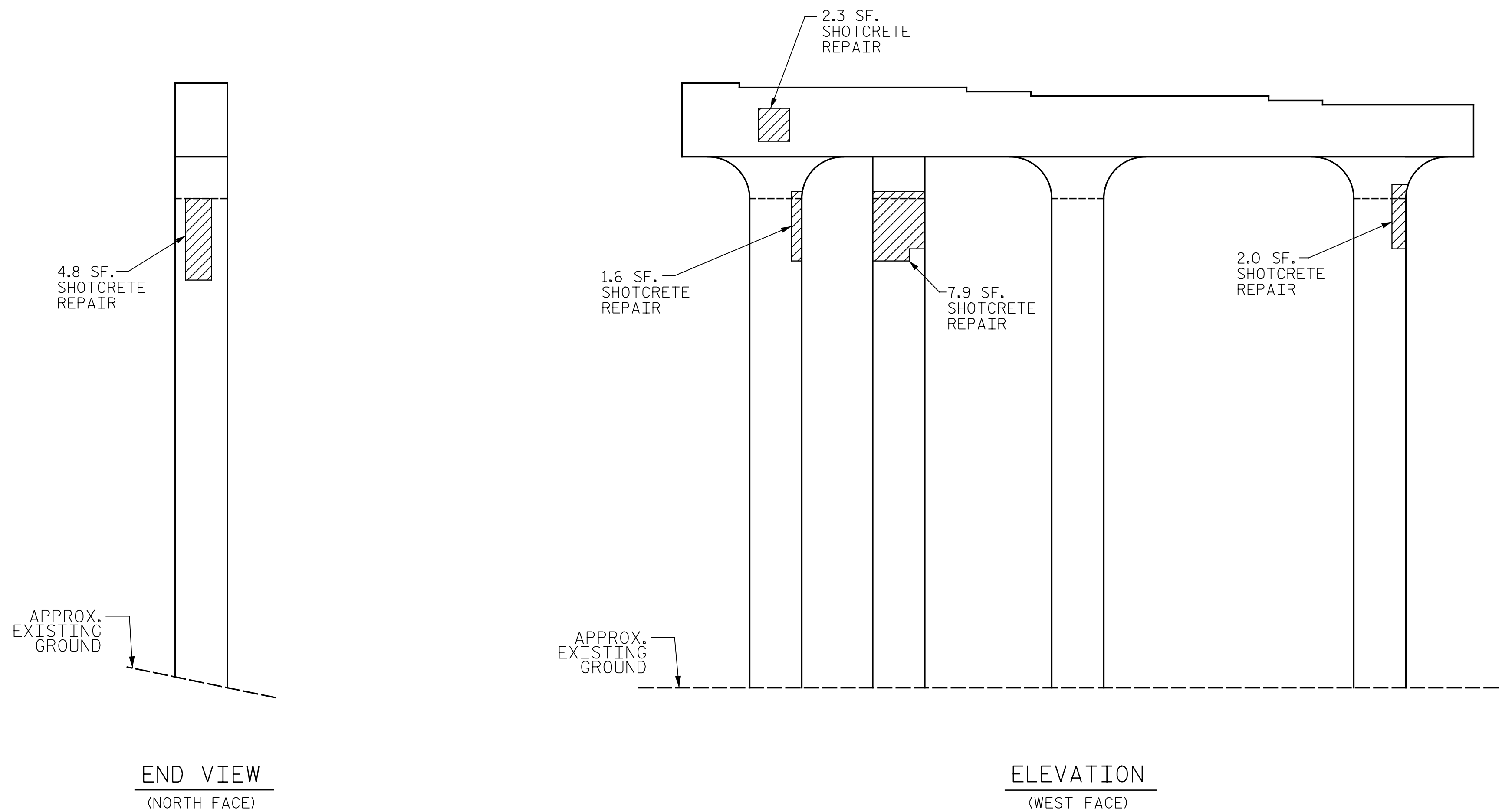

END VIEW  
(NORTH FACE)

ELEVATION  
(WEST FACE)

BENT 1  
(SPAN A SIDE)

PROJECT NO. I-5889A  
BUNCOMBE COUNTY  
 BRIDGE NO. 369



STATE OF NORTH CAROLINA  
 DEPARTMENT OF TRANSPORTATION  
 RALEIGH

**BENT 1  
 SPAN A FACE**

DRAWN BY : M.A. LEE DATE : 9/2017  
 CHECKED BY : R. NELSON DATE : 10/2017

PLANS PREPARED BY:  
  
 Excellence Delivered **As Promised**

2610 Wycliff Road  
 Suite 102  
 Raleigh, NC 27607-3073  
 (919) 420-7660  
 NC Lic. No. F-0270

DOCUMENT NOT CONSIDERED  
 FINAL UNLESS ALL  
 SIGNATURES COMPLETED

REVISIONS						SHEET NO.
NO.	BY:	DATE:	NO.	BY:	DATE:	S-142
1			3			TOTAL SHEETS
2			4			208