

EXISTING

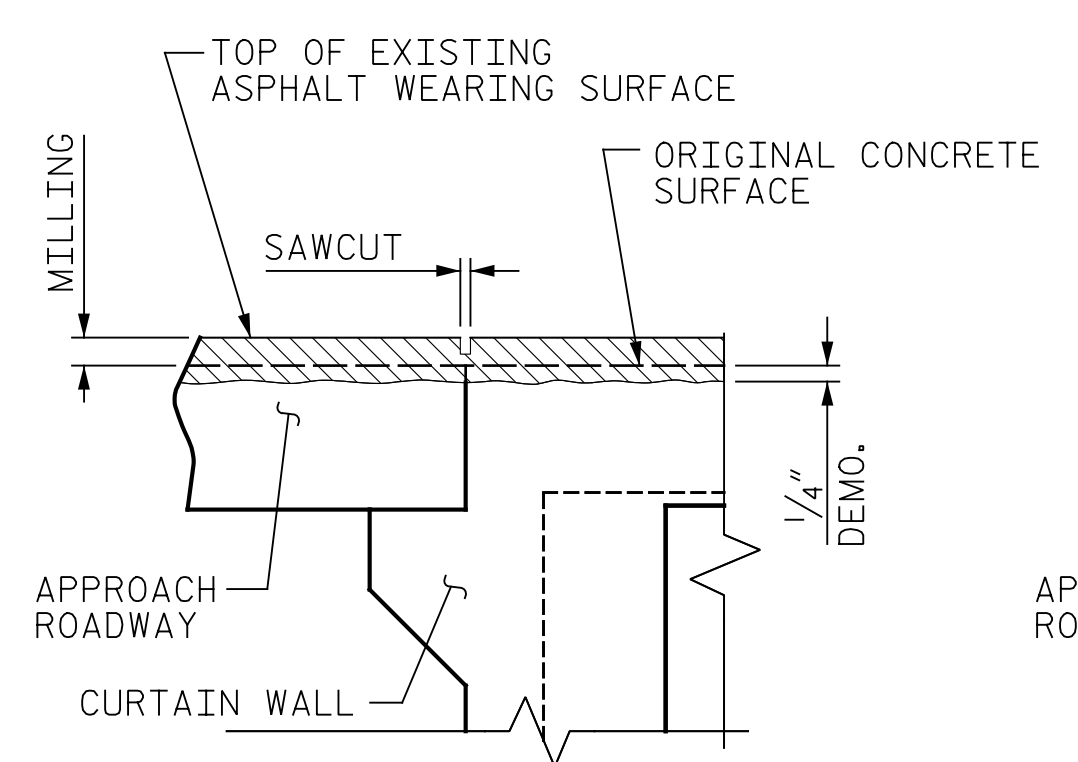

MINIMUM EXISTING JOINT DEMOLITION

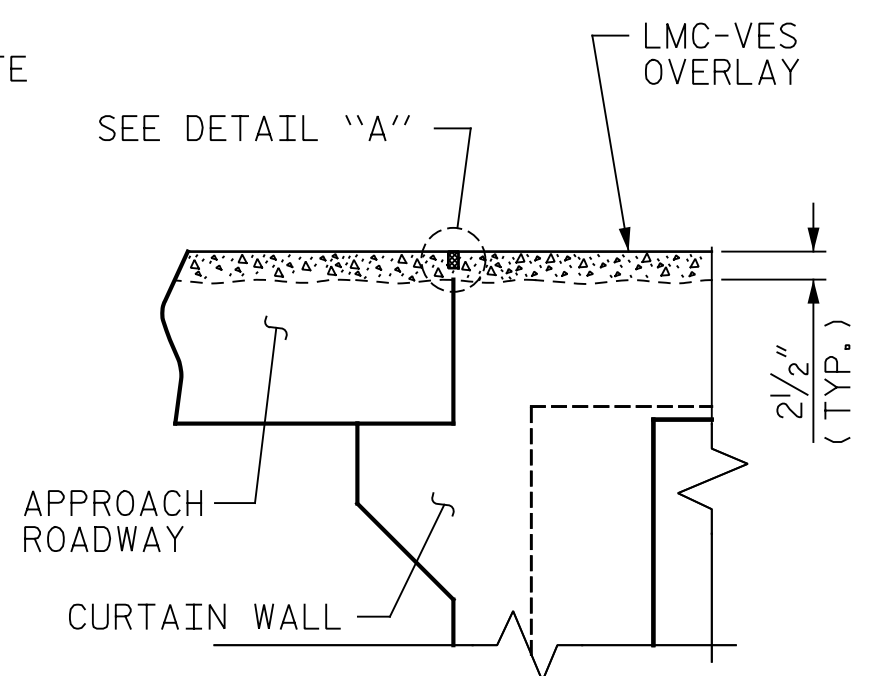

PROPOSED

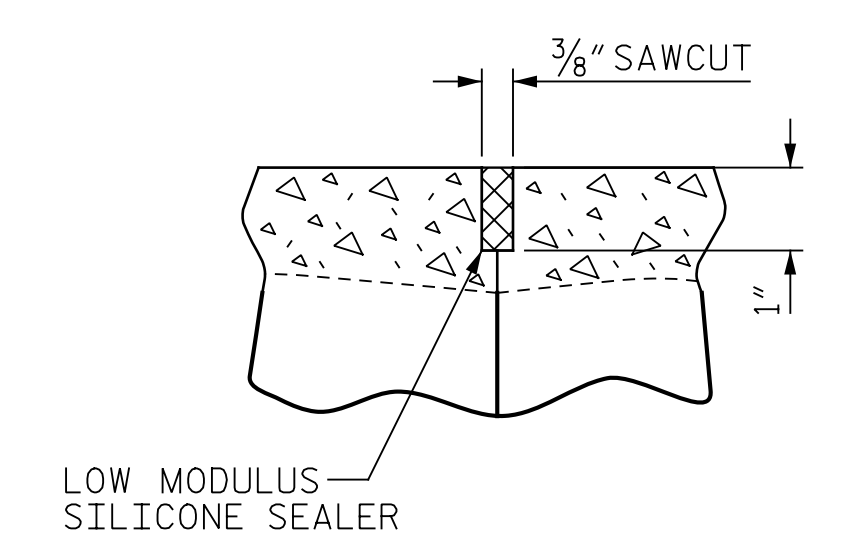

DETAIL "A"

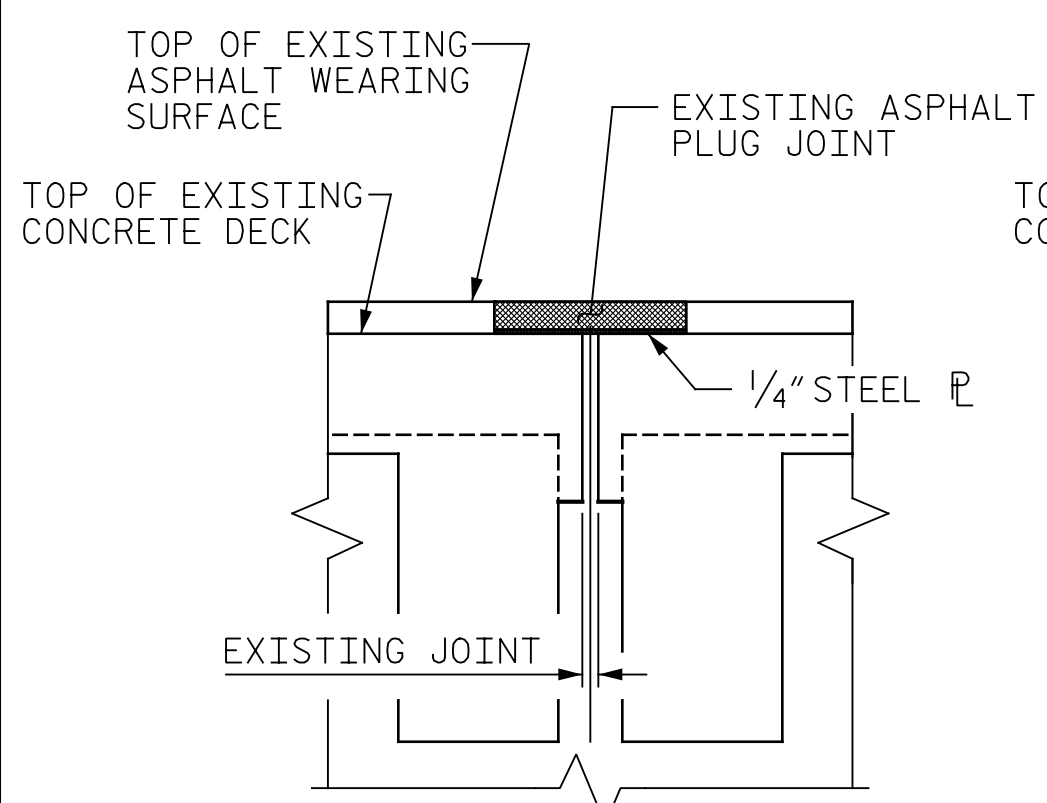

EXISTING JOINT

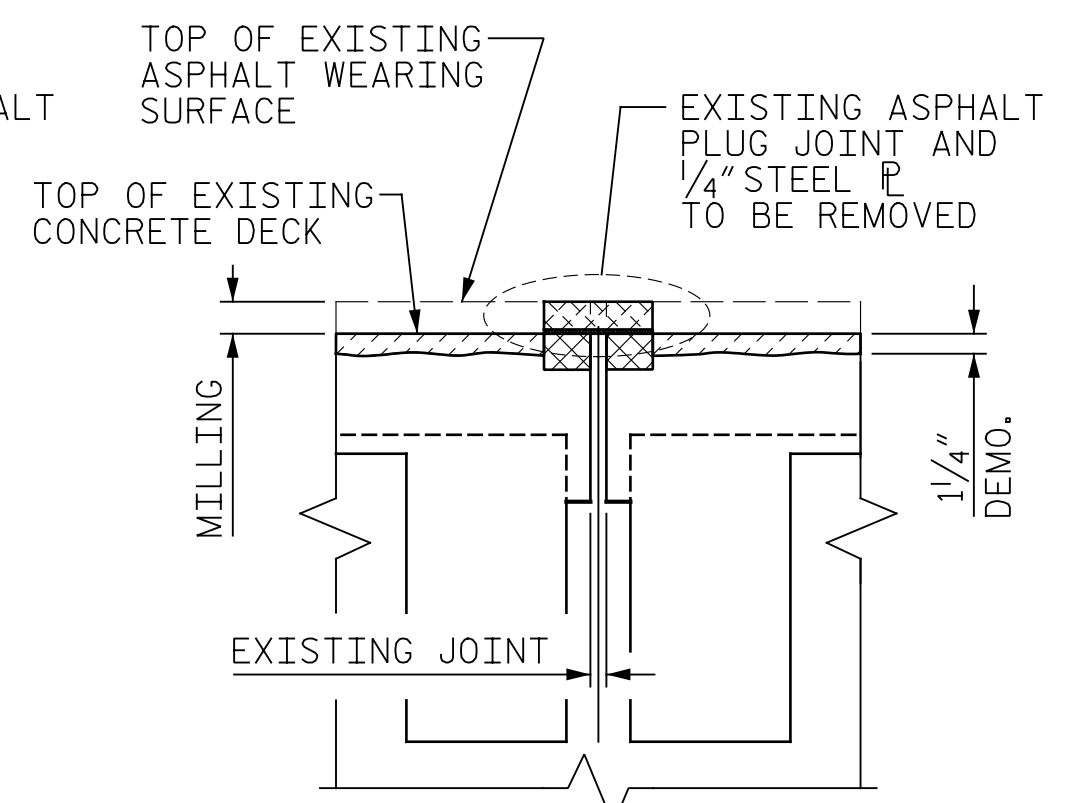

MINIMUM EXISTING JOINT DEMOLITION

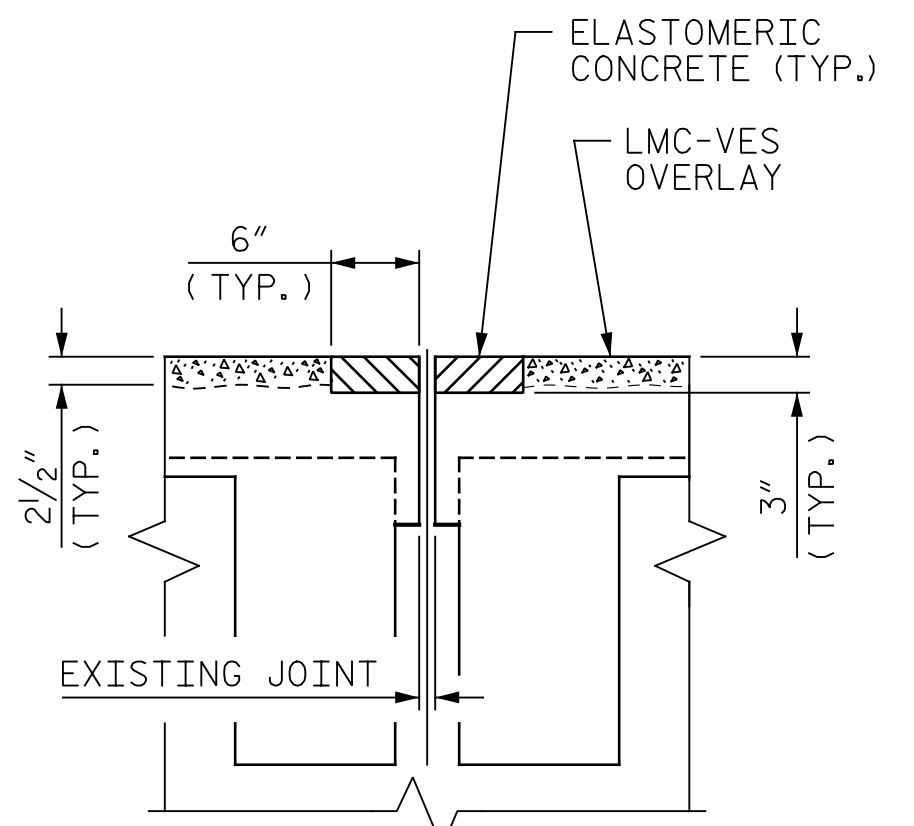

PROPOSED JOINT PRE-SAWED DIMENSIONS

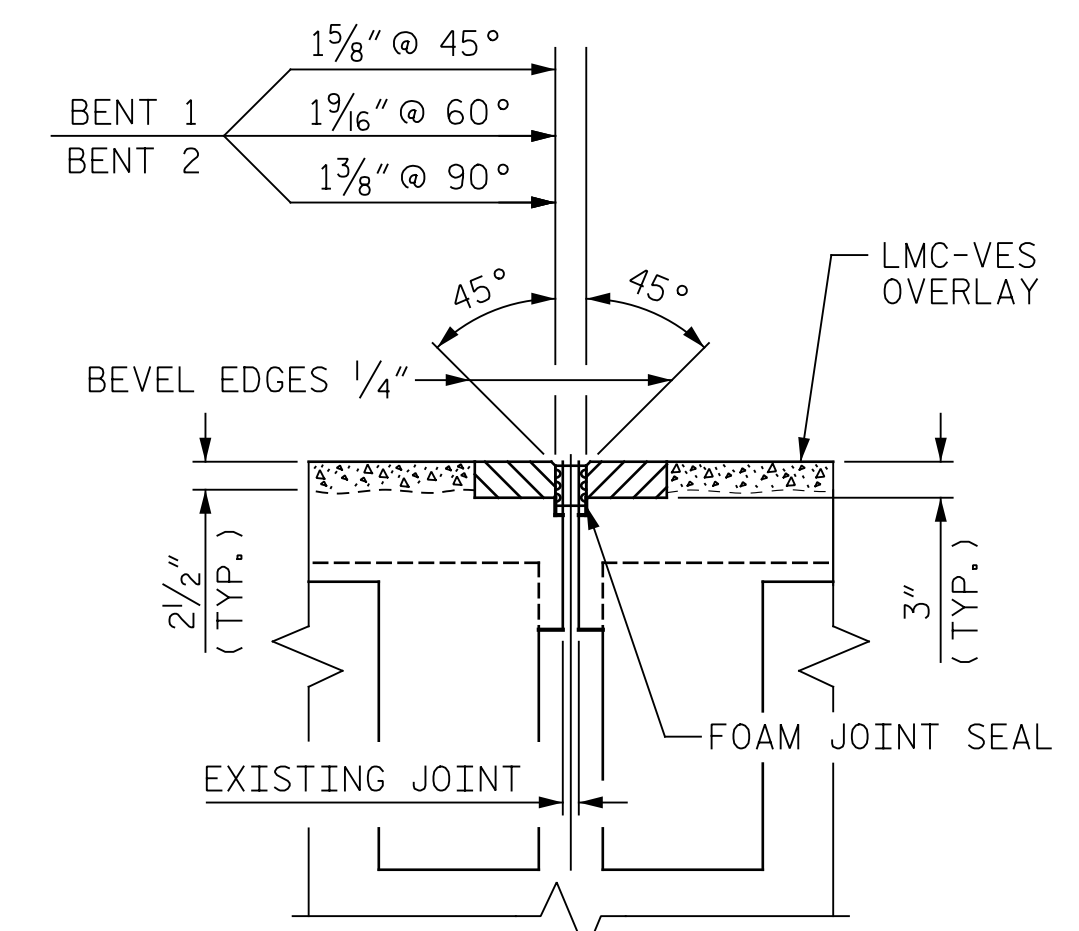

PROPOSED FOAM JOINT SEAL

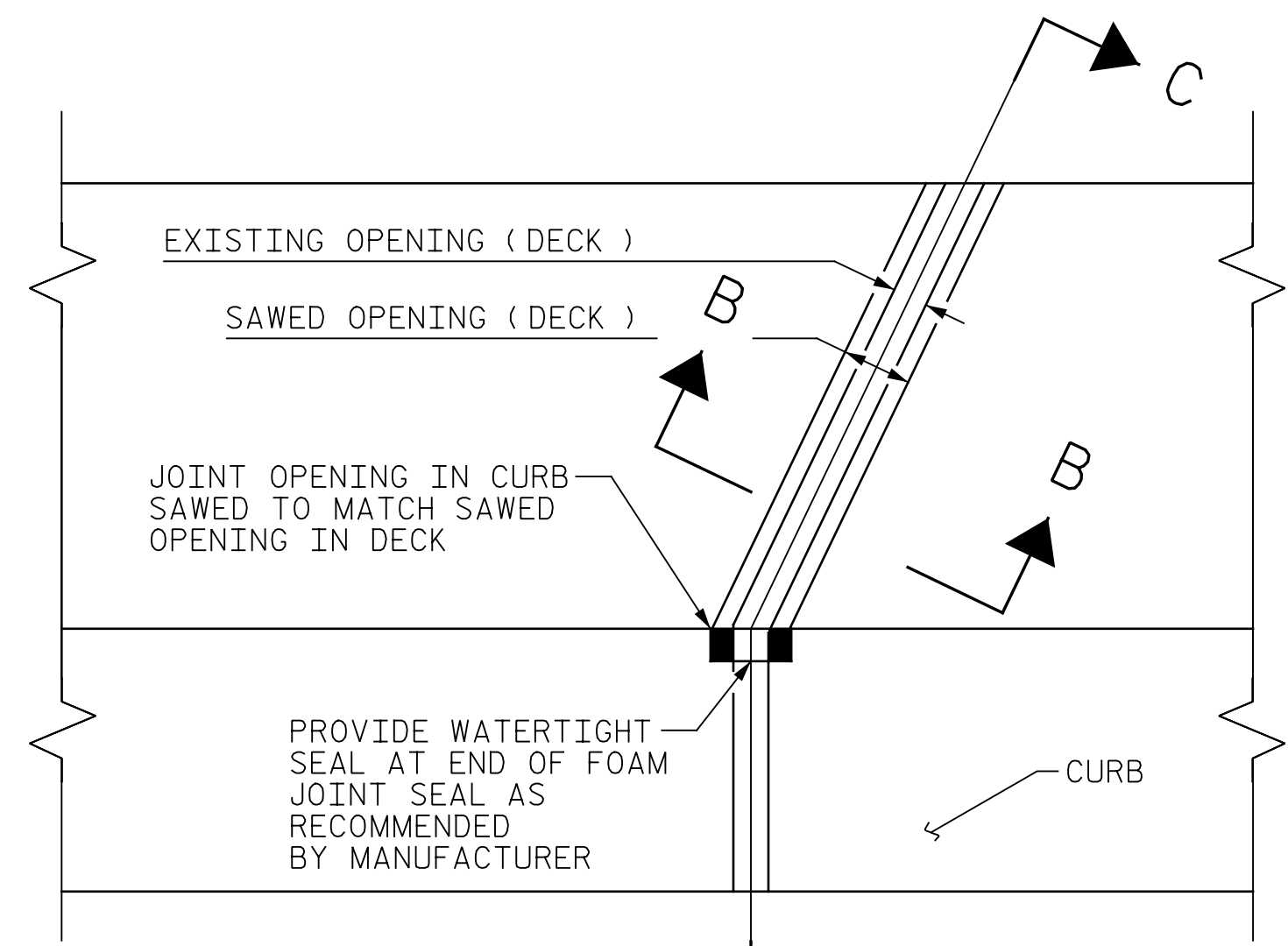

PLAN

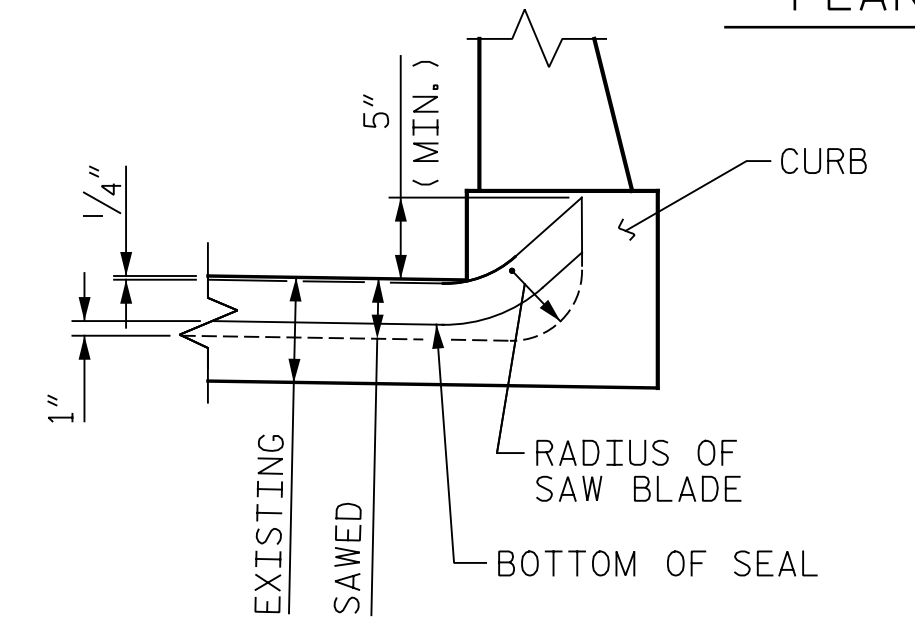

SECTION C-C

FOAM JOINT SEAL SHALL BE FACTORY FORMED OR CUT, HEAT WELDED AND TURNED UP PARALLEL TO FACE OF CURB.

IF THE EMBEDDED PORTION OF THE EXISTING PLASTIC WATERSTOP IS EXPOSED DURING REMOVAL OF UNSOUND CONCRETE OR IF UNSOUND CONCRETE IS REMOVED TO WITHIN 2" OF THE WATERSTOP, THE ENTIRE WATERSTOP SHALL BE REMOVED.

HYDRO-DEMOLITION OR EXCAVATION OF CONCRETE AT THE EXISTING JOINT SHALL RESULT IN THE BOTTOM OF THE EXCAVATION BEING REASONABLY FLAT AND LEVEL, TO PROVIDE SUFFICIENT SUBSTRATE FOR PLACEMENT AND SUPPORT OF ELASTOMERIC OR REPAIR CONCRETE. DEMOLISH BRIDGE JOINT TO THE NECESSARY DEPTH, SUCH THAT ELASTOMERIC CONCRETE SHALL BE FOUNDED ON CONCRETE OR REPAIR CONCRETE SUBSTRATE, NOT LATEX MODIFIED CONCRETE

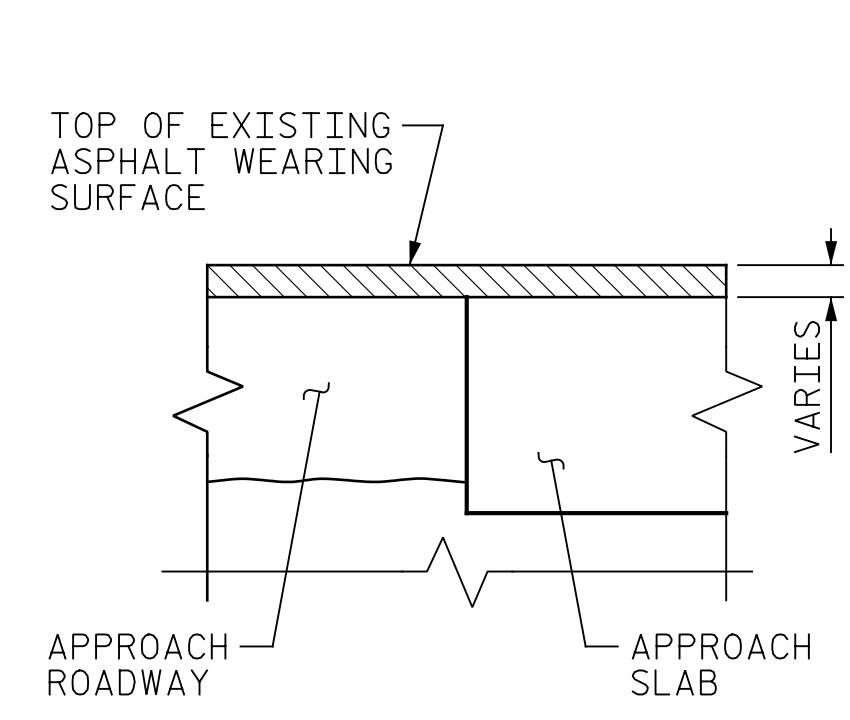

EXISTING

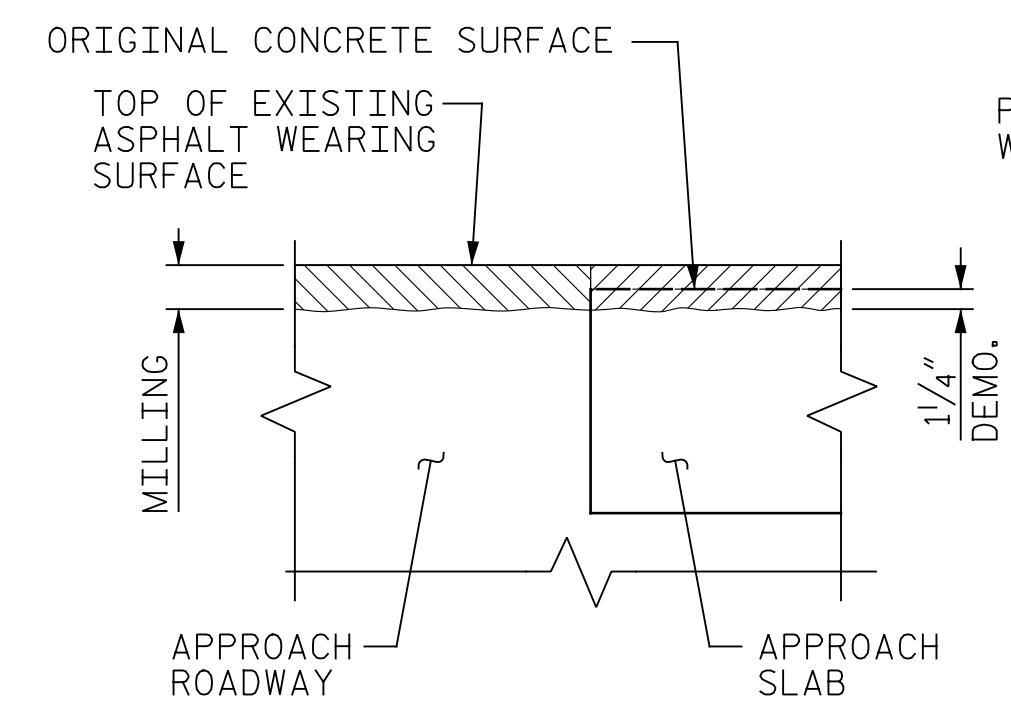

MINIMUM EXISTING JOINT DEMOLITION

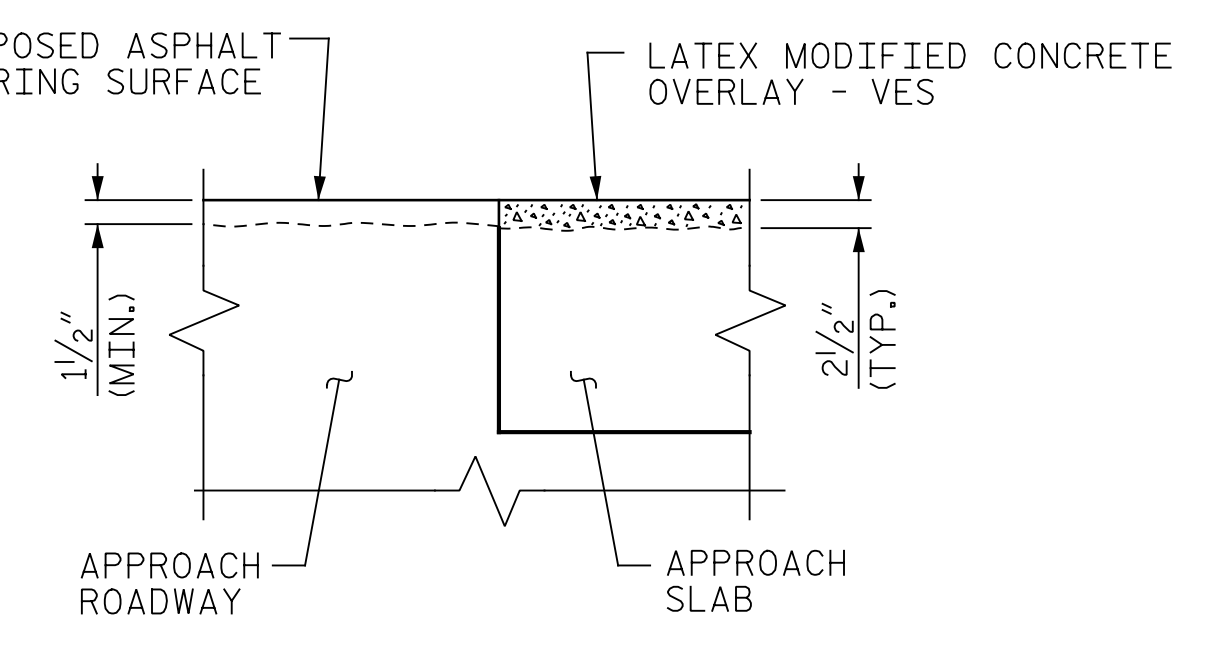

PROPOSED

SECTION D-D



DocuSigned by: Eric B. Nelson 11/16/2017

PROJECT NO. I-5889A
BUNCOMBE COUNTY
BRIDGE NO. 358

STATE OF NORTH CAROLINA
DEPARTMENT OF TRANSPORTATION
RALEIGH

JOINT DETAILS

DRAWN BY: M.A. LEE DATE: 9/2017
CHECKED BY: R. NELSON DATE: 10/2017

PLANS PREPARED BY: Gannett Fleming
2610 Wycliff Road, Suite 102, Raleigh, NC 27607-3073
(919) 420-7660
NC Lic. No. F-0270

DOCUMENT NOT CONSIDERED FINAL UNLESS ALL SIGNATURES COMPLETED

REVISIONS						SHEET NO.
NO.	BY:	DATE:	NO.	BY:	DATE:	S-93
1			3			TOTAL SHEETS
2			4			208