

6/2/99

- NOTES:
1. DESIGN AND CONSTRUCTION REQUIRES TOLL GANTRY STRUCTURES TO ACCOMMODATE WIND VELOCITY OF 90 M.P.H.
  2. SEE AESTHETIC DESIGN STANDARDS FOR ADDITIONAL REQUIREMENTS.
  3. THE EXACT SPAN DIMENSIONS SHALL BE DETERMINED BY THE FABRICATOR.
  4. THE "S" DIMENSIONS ARE CALCULATED BASED ON THEORETICAL CROSS SECTIONS AND HAVE NOT BEEN FIELD VERIFIED. GRADING AND ROADWAY MUST BE CONSTRUCTED PER CONTRACT PLANS FOR THESE DIMENSIONS TO BE APPROPRIATE.
  5. SEE STRUCTURE PLANS FOR ADDITIONAL DIMENSIONS AND DETAILS.

PROJECT REFERENCE NO. U-5315 A&B	SHEET NO. GAN-5
ROADWAY DESIGN ENGINEER NORTH CAROLINA PROFESSIONAL SEAL 044558 ENGINEER DAVID T. SEARS 11/10/2017	
Documented by David T. Sears <b>DOCUMENT NOT CONSIDERED FINAL UNLESS ALL SIGNATURES COMPLETED</b>	

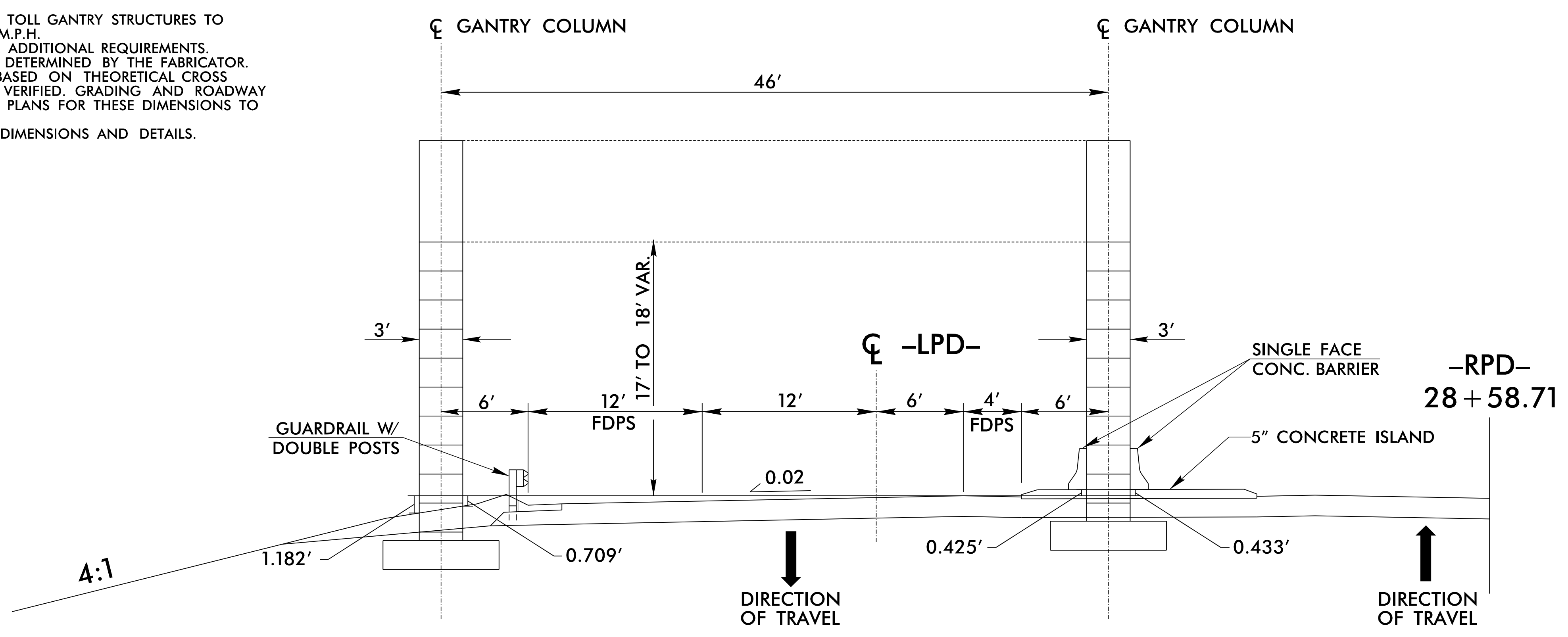

**TOLL GANTRY NO. 3**  
-LPD- STA. 21+16

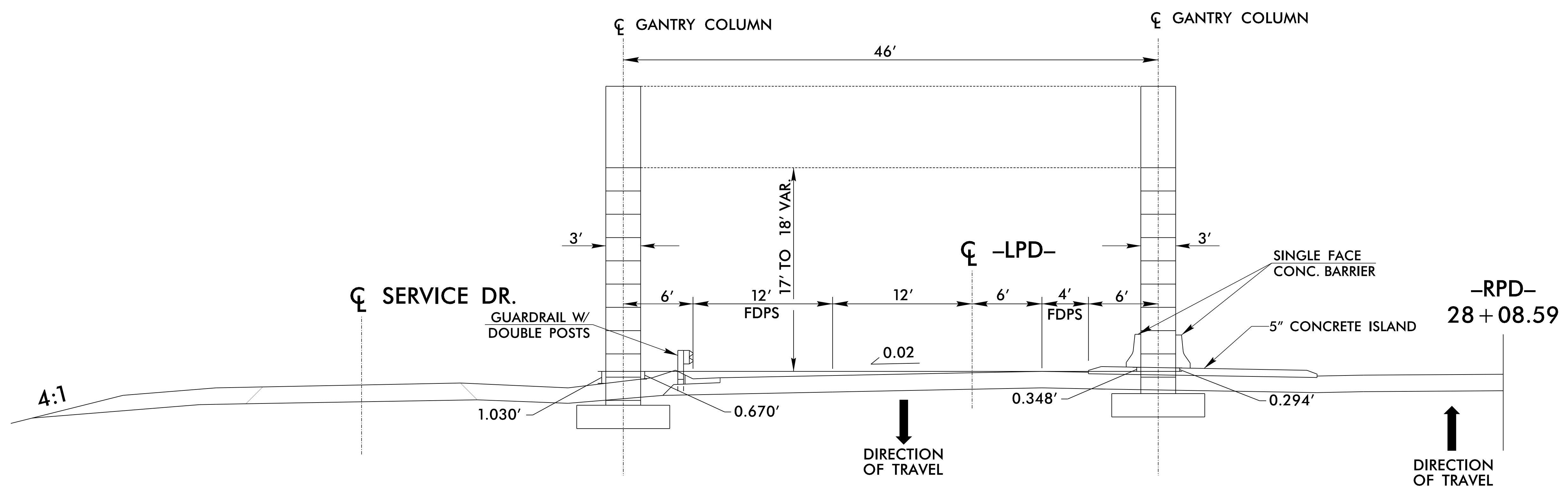

**TOLL GANTRY NO. 4**  
-LPD- STA. 20+66

11/10/2017 1:10:11 PM I:\ITS\IDGN\U5315\_CAN\_psh05.dgn

PLANS PREPARED BY :

**RK&K**

RUMMEL, KLEPPER & KAHL, LLP  
900 RIDGEFIELD DRIVE SUITE 350  
RALEIGH, NORTH CAROLINA 27609-3960  
NC LICENSE NO. F-0112 • (919) 878-9560