

INFILTRATION BASIN WITH BAFFLES DETAIL (EAST)

PROJECT REFERENCE NO. R-5703	SHEET NO. EC-2D
RW SHEET NO.	
ROADWAY DESIGN ENGINEER	HYDRAULICS ENGINEER

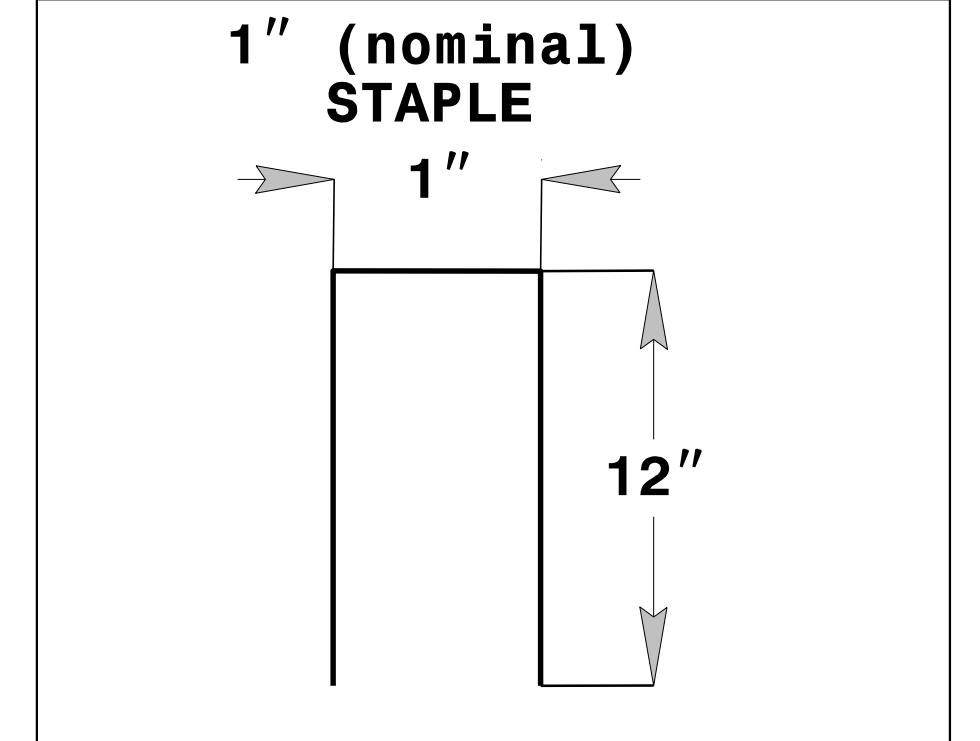
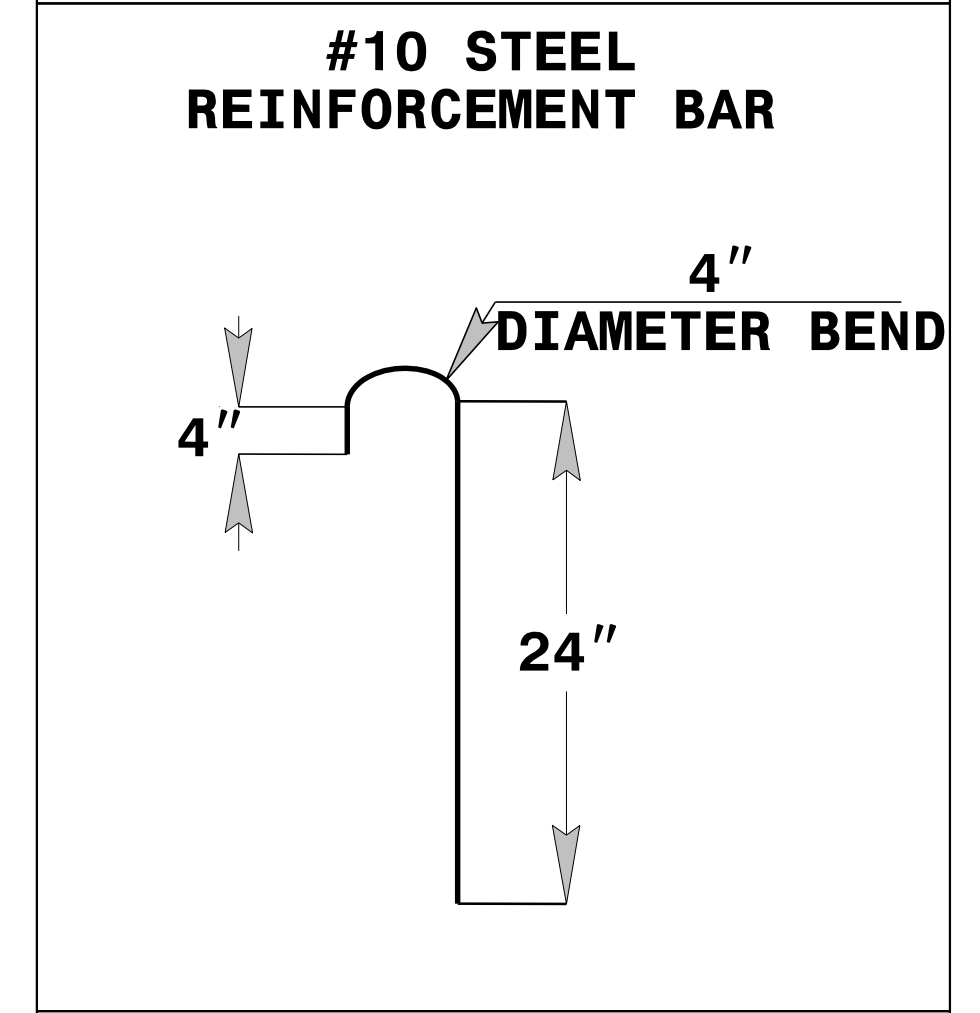
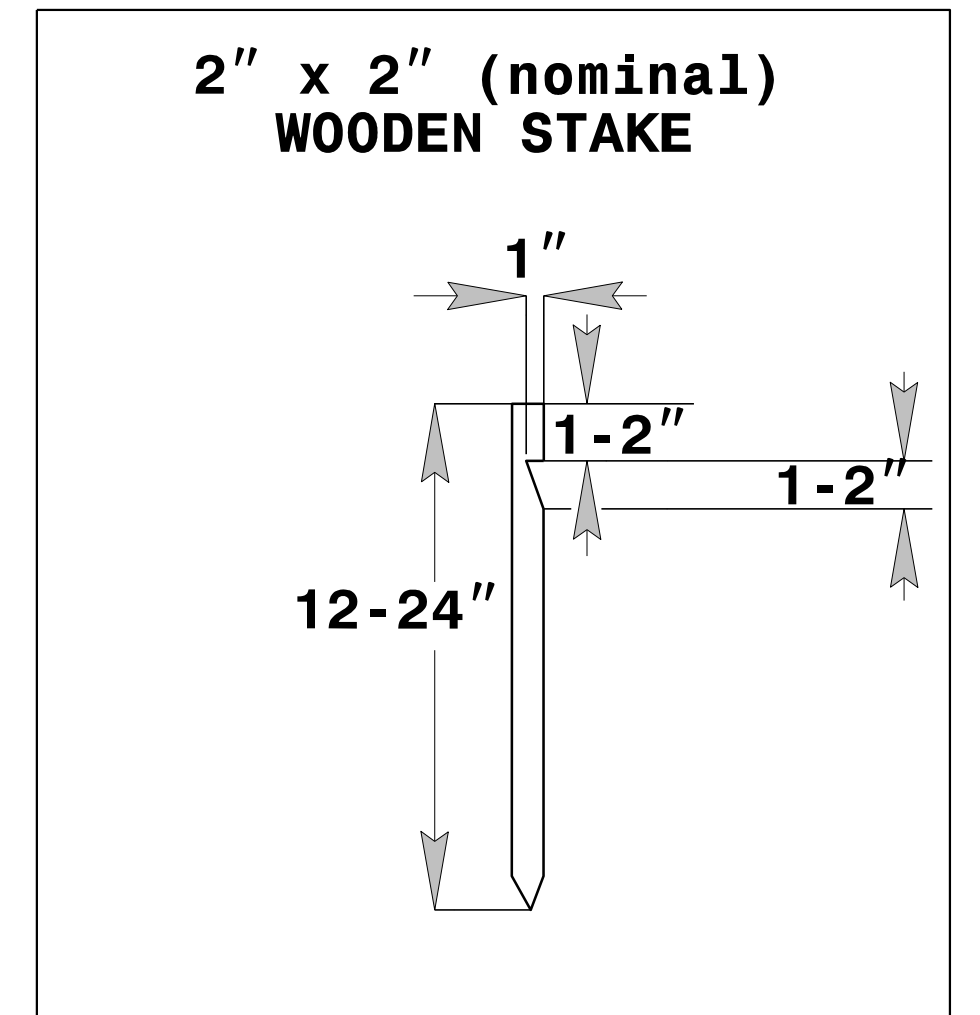
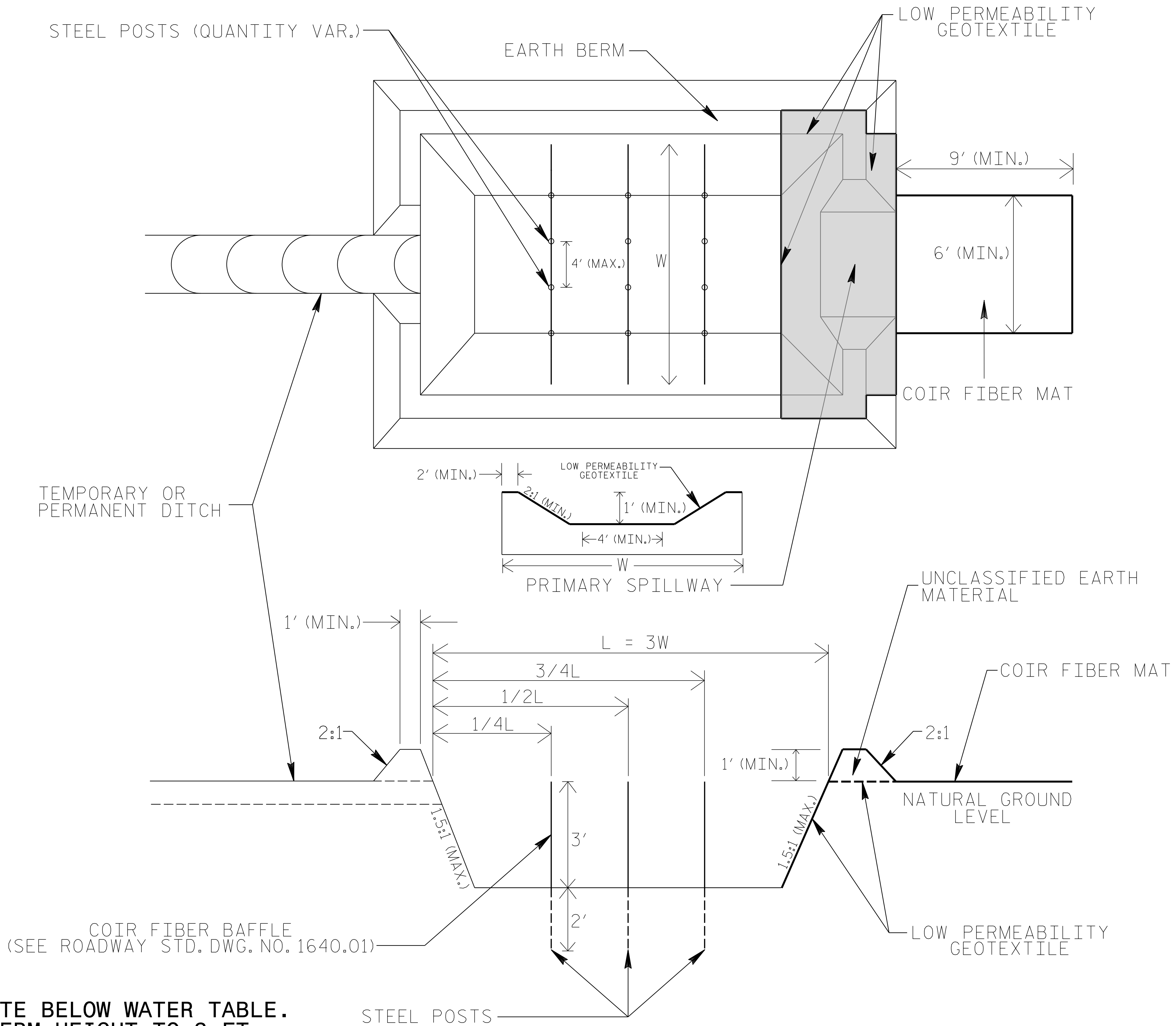

COIR FIBER MAT ANCHOR OPTIONS

NOTES

1. DO NOT EXCAVATE BELOW WATER TABLE.
2. LIMIT EARTH BERM HEIGHT TO 3 FT.
3. AVOID COMPACTING BOTTOM OF BASIN.
4. FOR BASIN DEPTH OF 3 FT., THE MINIMUM BASIN WIDTH SHALL BE 9 FT.
5. DETERMINE PRIMARY SPILLWAY LENGTH (FT.) USING $Q/0.8$, WHERE Q IS FLOW RATE (CFS) INTO BASIN.

NOT TO SCALE