

NOTES:
 FOR NOTES, SEE SHEET 1 OF 2.
 FOR TRAFFIC SIGNAL SUPPORT LOCATIONS AND ADDITIONAL DETAILS, SEE "TRAFFIC SIGNAL SUPPORT DETAILS" SHEET.
 FOR 4" Ø ELECTRICAL CONDUIT DETAILS, SEE "ELECTRICAL CONDUIT SYSTEM FOR SIGNALS" SHEET.
 LOCATION OF 4" Ø ELECTRICAL CONDUIT IS NOT EXACT AND SHALL BE FIELD VERIFIED.

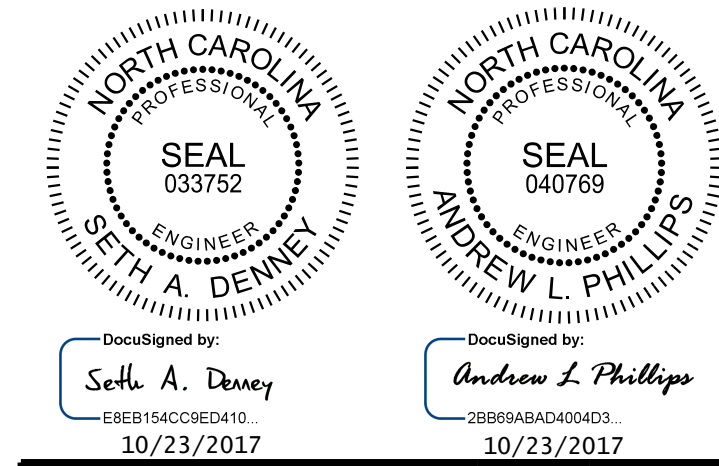
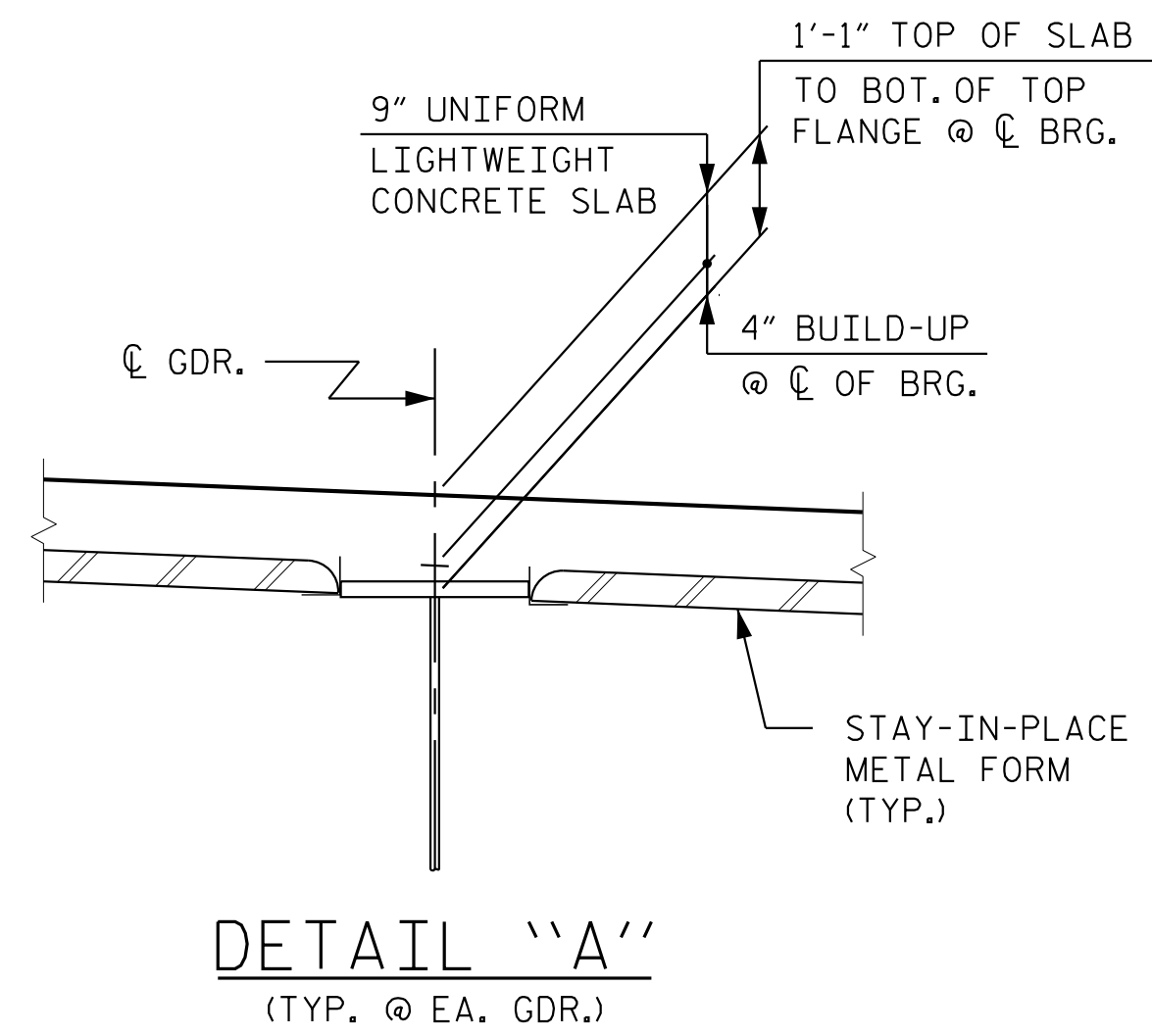
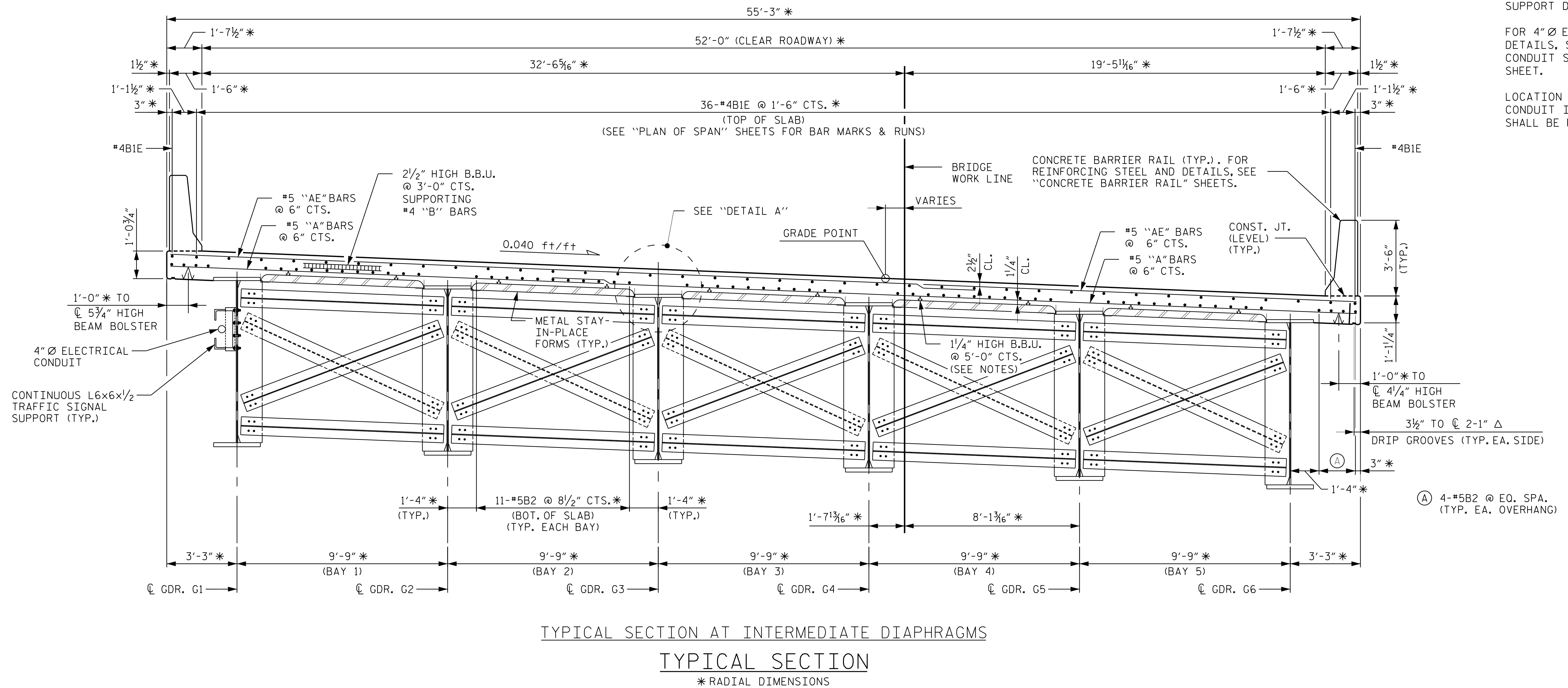

Kimley-Horn
 421 Fayetteville Street, Suite 600
 Raleigh, NC 27601-1772
 Phone (919) 677-2000
 NC LICENSE # F-0102

PROJECT NO. U-5806
CABARRUS COUNTY
 STATION: 15+75.56 -Y1-
27+06.95 -L-
 SHEET 2 OF 2

STATE OF NORTH CAROLINA DEPARTMENT OF TRANSPORTATION RALEIGH					
SUPERSTRUCTURE TYPICAL SECTION					
REVISIONS					
NO.	BY:	DATE:	NO.	BY:	DATE:
1			3		
2			4		
					SHEET NO. S-12
					TOTAL SHEETS 50

K:\B01-Structures\Bridges\NC\011036388 - U-5806 - Final Design\Cad\Drawings\U-5806 - IS02.dgn

DRAWN BY: D. D. LOWERY DATE: 10/17
 CHECKED BY: A. L. PHILLIPS DATE: 10/17
 DESIGN ENGINEER OF RECORD: S. A. DENNEY DATE: 10/17

**DOCUMENT NOT CONSIDERED FINAL
 UNLESS ALL SIGNATURES COMPLETED**

This document, together with the concepts and designs presented herein, is an integral part of the project. It is not to be used for any other project without written authorization and approval by Kimley-Horn and Associates, Inc. shall be without liability to Kimley-Horn and Associates, Inc.