

### EDI MODEL 2018ECLIP-NC CONFLICT MONITOR PROGRAMMING DETAIL

(remove jumpers and set switches as shown)

REMOVE DIODE JUMPERS 1-5, 1-6, 1-9, 1-11, 2-5, 2-6, 2-9, 2-11, 3-7, 3-8, 3-10, 3-12, 4-7, 4-8, 4-10, 4-12, 5-9, 5-11, 6-9, 6-11, 7-10, 7-12, 8-10, 8-12, 9-11, and 10-12.

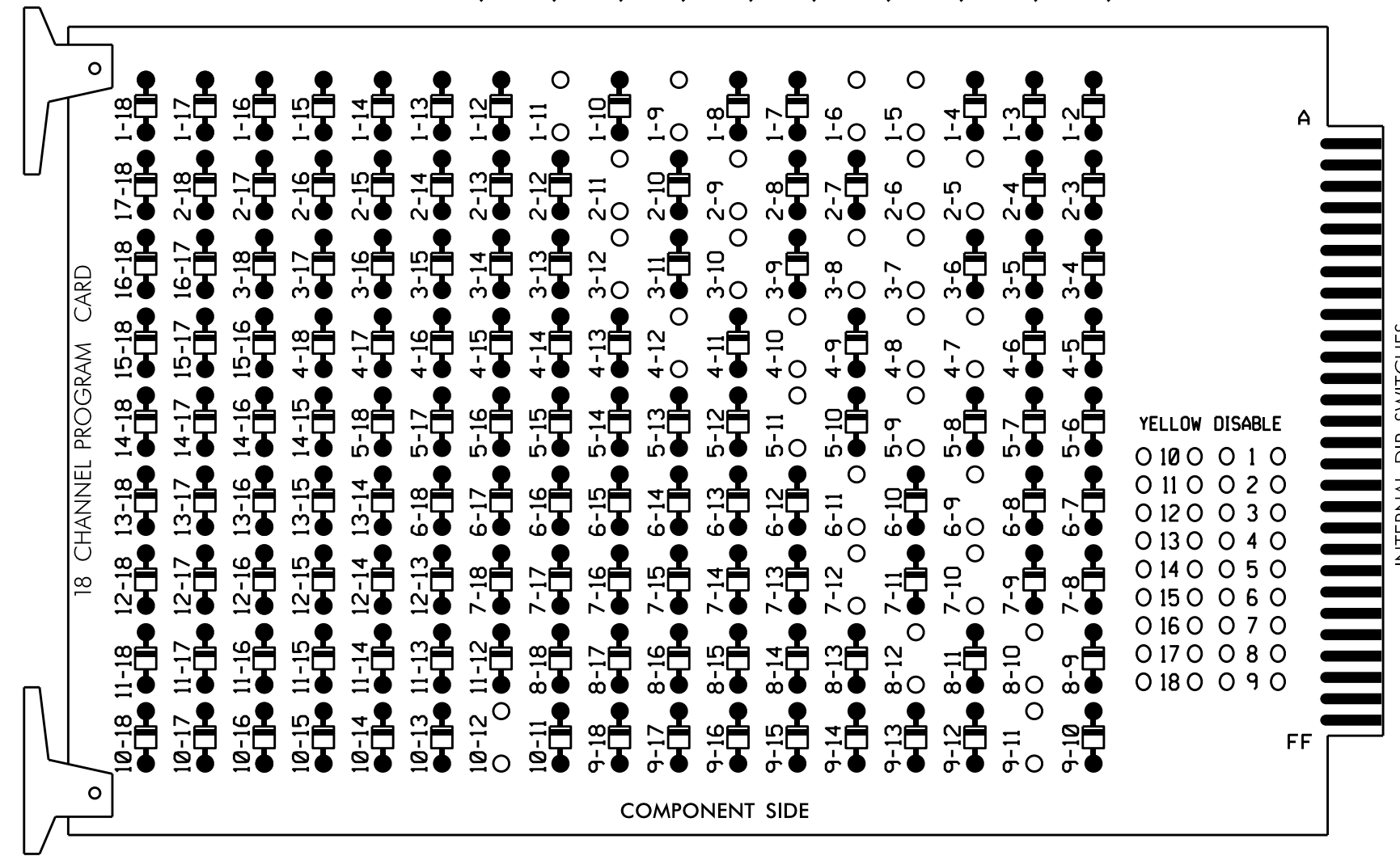

REMOVE JUMPERS AS SHOWN

NOTES:

- Card is provided with all diode jumpers in place. Removal of any jumper allows its channels to run concurrently.
- Ensure jumpers SEL2-SEL5 and SEL9 are present on the monitor board.
- Ensure that Red Enable is active at all times during normal operation.
- Integrate monitor with Ethernet network in cabinet.

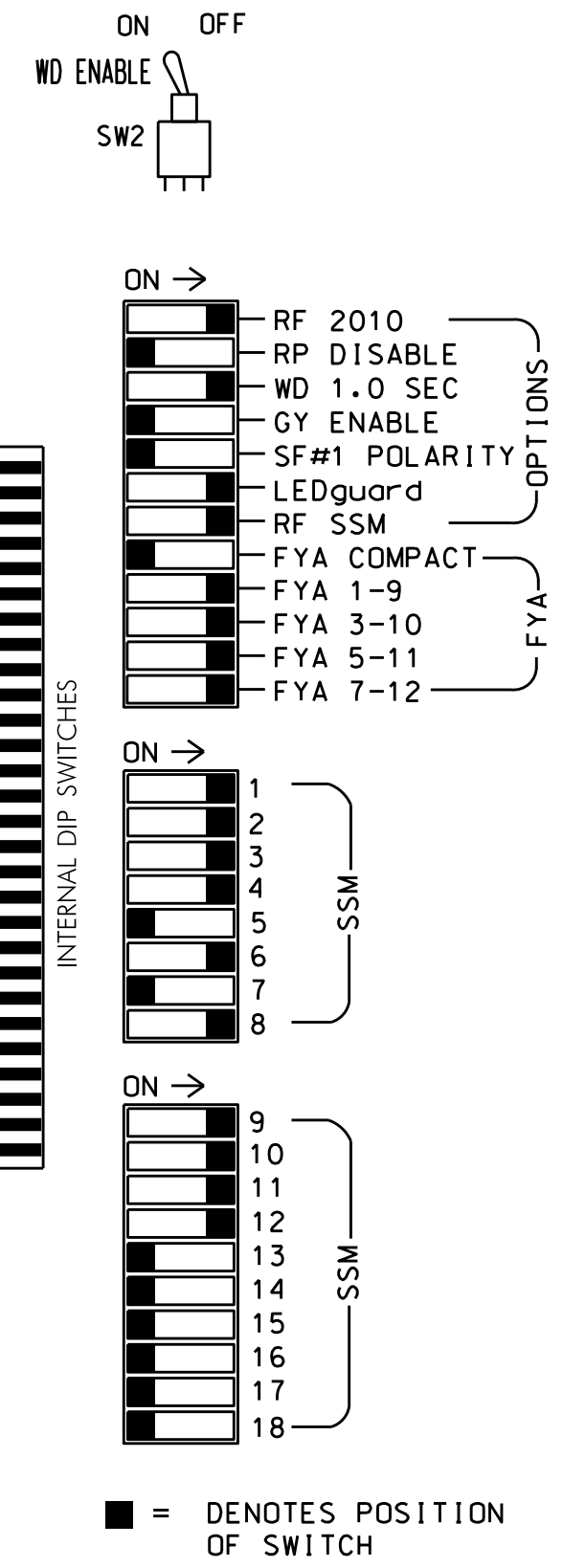

### NOTES

- To prevent "flash-conflict" problems, insert red flash program blocks for all unused vehicle load switches in the output file. The installer shall verify that signal heads flash in accordance with the Signal Plans.
- Program phases 4 and 8 for Dual Entry.
- Enable Simultaneous Gap-Out for all Phases.
- Program phases 2 and 6 for volume density operation.
- Program controller to start up in phase 2 Green and 6 Green.
- The cabinet and controller are part of the Concord Mills Blvd. CLS.

### EQUIPMENT INFORMATION

CONTROLLER.....2070E  
 CABINET.....332 W/AUX  
 SOFTWARE.....ECONOLITE ASC/3-2070  
 CABINET MOUNT.....BASE  
 OUTPUT FILE POSITIONS...18 WITH AUX. OUTPUT FILE  
 LOAD SWITCHES USED.....S1,S2,S4,S5,S7,S8,S10,S11,  
 AUX S1,AUX S2,AUX S4,AUX S5  
 PHASES USED.....1,2,3,4,5,6,7,8  
 OVERLAP "A".....\*  
 OVERLAP "B".....\*  
 OVERLAP "C".....\*  
 OVERLAP "D".....\*  
 \* See overlap programming detail on sheet 2

### SIGNAL HEAD HOOK-UP CHART

| LOAD SWITCH NO.       | S1  | S2    | S3    | S4 | S5  | S6    | S7    | S8 | S9    | S10      | S11 | S12   | AUX S1   | AUX S2 | AUX S3 | AUX S4 | AUX S5 | AUX S6 |    |    |  |
|-----------------------|-----|-------|-------|----|-----|-------|-------|----|-------|----------|-----|-------|----------|--------|--------|--------|--------|--------|----|----|--|
| CMU CHANNEL NO.       | 1   | 2     | 13    | 3  | 4   | 14    | 5     | 6  | 15    | 7        | 8   | 16    | 9        | 10     | 17     | 11     | 12     | 18     |    |    |  |
| PHASE                 | 1   | 2     | 2 PED | 3  | 4   | 4 PED | 5     | 6  | 6 PED | 7        | 8   | 8 PED | OLA      | OLB    | SPARE  | OLC    | OLD    | SPARE  |    |    |  |
| SIGNAL HEAD NO.       | 11  | 82,83 | 21,22 | NU | 22  | 31    | 41,42 | NU | 51    | 61,62,63 | NU  | 71    | 81,82,83 | NU     | 11     | 31     | NU     | 51     | 71 | NU |  |
| RED                   |     | *     | 128   |    | *   | 101   |       |    | 134   |          |     | 107   |          |        |        |        |        |        |    |    |  |
| YELLOW                |     |       | 129   |    |     | 102   |       | *  | 135   |          | *   | 108   |          |        |        |        |        |        |    |    |  |
| GREEN                 |     |       | 130   |    |     | 103   |       |    | 136   |          |     | 109   |          |        |        |        |        |        |    |    |  |
| RED ARROW             |     |       |       |    |     |       |       |    |       |          |     |       | A121     | A124   |        | A114   | A101   |        |    |    |  |
| YELLOW ARROW          |     | 126   |       |    | 117 |       |       |    |       |          |     |       | A122     | A125   |        | A115   | A102   |        |    |    |  |
| FLASHING YELLOW ARROW |     |       |       |    |     |       |       |    |       |          |     |       | A123     | A126   |        | A116   | A103   |        |    |    |  |
| GREEN ARROW           | 127 | 127   |       |    | 118 | 118   |       |    | 133   |          |     | 124   |          |        |        |        |        |        |    |    |  |

NU = Not Used  
 \* Denotes install load resistor. See load resistor installation detail this sheet.  
 \* See pictorial of head wiring in detail this sheet.

### INPUT FILE POSITION LAYOUT

(front view)

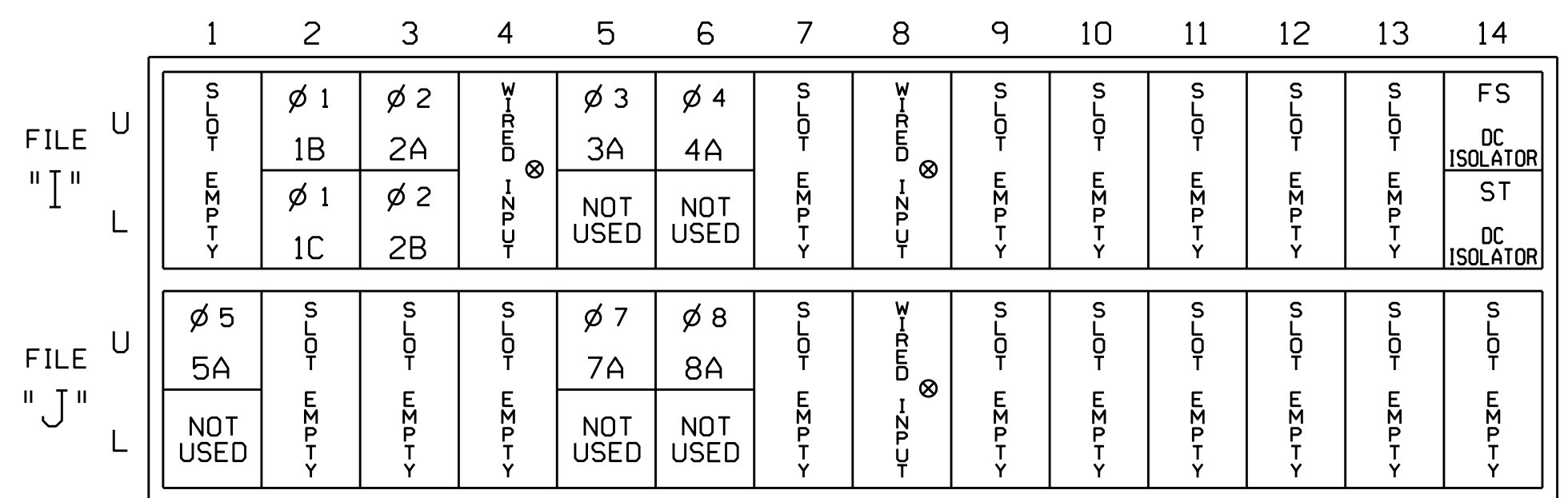

EX.: 1A, 2A, ETC. = LOOP NO.'S  
 FS = FLASH SENSE  
 ST = STOP TIME  
 \* Wired Input - Do not populate slot with detector card

### INPUT FILE CONNECTION & PROGRAMMING CHART

| LOOP NO.        | LOOP TERMINAL | INPUT FILE POS. | PIN NO. | DETECTOR NO. | NEMA PHASE | CALL | EXTEND TIME | DELAY TIME | DETECTOR TYPE |
|-----------------|---------------|-----------------|---------|--------------|------------|------|-------------|------------|---------------|
| 1B              | TB2-5,6       | I2U             | 39      | 2            | 1          | YES  |             | 15         | S             |
| 1C              | TB2-7,8       | I2L             | 43      | 12           | 1          | YES  |             | 15         | S             |
| 2A              | TB2-9,10      | I3U             | 63      | 32           | 2          | YES  |             |            | S             |
| 2B              | TB2-11,12     | I3L             | 76      | 42           | 2          | YES  |             |            | S             |
| 3A <sup>1</sup> | TB4-5,6       | I5U             | 58      | 3            | 3          | YES  |             | 15         | S             |
|                 | -             | J8U             | 50      | 28           | 8          | YES  |             |            | S             |
| 4A              | TB4-9,10      | I6U             | 41      | 4            | 4          | YES  |             | 10         | S             |
| 5A <sup>2</sup> | TB3-1,2       | J1U             | 55      | 5            | 5          | YES  |             | 15         | S             |
|                 | -             | I4U             | 47      | 22           | 2          | YES  |             | 3          | G             |
| 7A <sup>3</sup> | TB5-5,6       | J5U             | 57      | 7            | 7          | YES  |             | 15         | S             |
|                 | -             | I8U             | 49      | 24           | 4          | YES  |             | 3          | S             |
| 8A              | TB5-9,10      | J6U             | 42      | 8            | 8          | YES  |             |            | S             |

- Add jumper from I5-W to J8-W, on rear of input file.
- Add jumper from J1-W to I4-W, on rear of input file.
- Add jumper from J5-W to I8-W, on rear of input file.

### INPUT FILE POSITION LEGEND: J2L

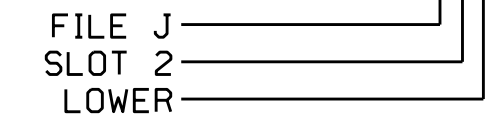

### SPECIAL DETECTOR NOTE

Install a video detection system for vehicle detection. Perform installation according to manufacturer's directions and NCDOT engineer-approved mounting locations to accomplish the detection schemes shown on the Signal Design Plans for the following loops: 1A, 6A, 6B, 6C, 6D, 6E, and 6F.

### LOAD RESISTOR INSTALLATION DETAIL

(install resistors as shown below)

| VALUE (ohms) | WATTAGE   |
|--------------|-----------|
| 1.5K - 1.9K  | 25W (min) |
| 2.0K - 3.0K  | 10W (min) |

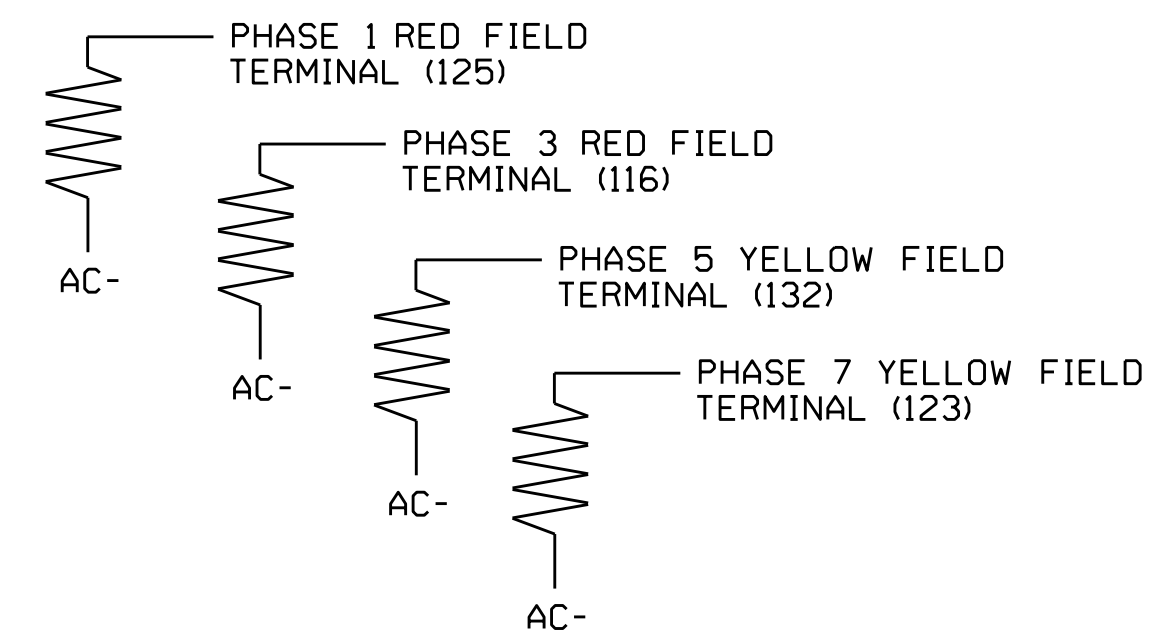

THIS ELECTRICAL DETAIL IS FOR THE SIGNAL DESIGN: 10-1733T1  
 DESIGNED: August 2017  
 SEALED: 9/25/2017  
 REVISED: N/A

Electrical Detail - Temp Design 1 - Phase I - Sheet 1 of 2

SR 2894 (Concord Mills Blvd.) at Concord Mills Entrance/Bexley Way

Division 10 Cabarrus County Concord

PLAN DATE: September 2017 REVIEWED BY:

PREPARED BY: S. Armstrong REVIEWED BY:

REVISIONS INIT. DATE

750 N. Greenfield Pkwy, Garner, NC 27529

9/26/2017

SIG. INVENTORY NO. 10-1733T1

DOCUMENT NOT CONSIDERED FINAL UNLESS ALL SIGNATURES COMPLETED

SEAL

SEAL 030530

SEAL

9/26/2017

DATE

9/26/2017

DATE