

**NOTES**

STIRRUPS IN CAP MAY BE SHIFTED AS NECESSARY TO CLEAR DOWELS.

THE CONCRETE IN THE SHADED AREA OF THE WING SHALL BE POURED AFTER THE VERTICAL CONCRETE BARRIER RAIL IS CAST IF SLIP FORMING IS USED.

FOR PILE SPLICE DETAILS, SEE SHEET 4 OF 4.

FOR WING DETAILS, SEE SHEET 3 OF 4.

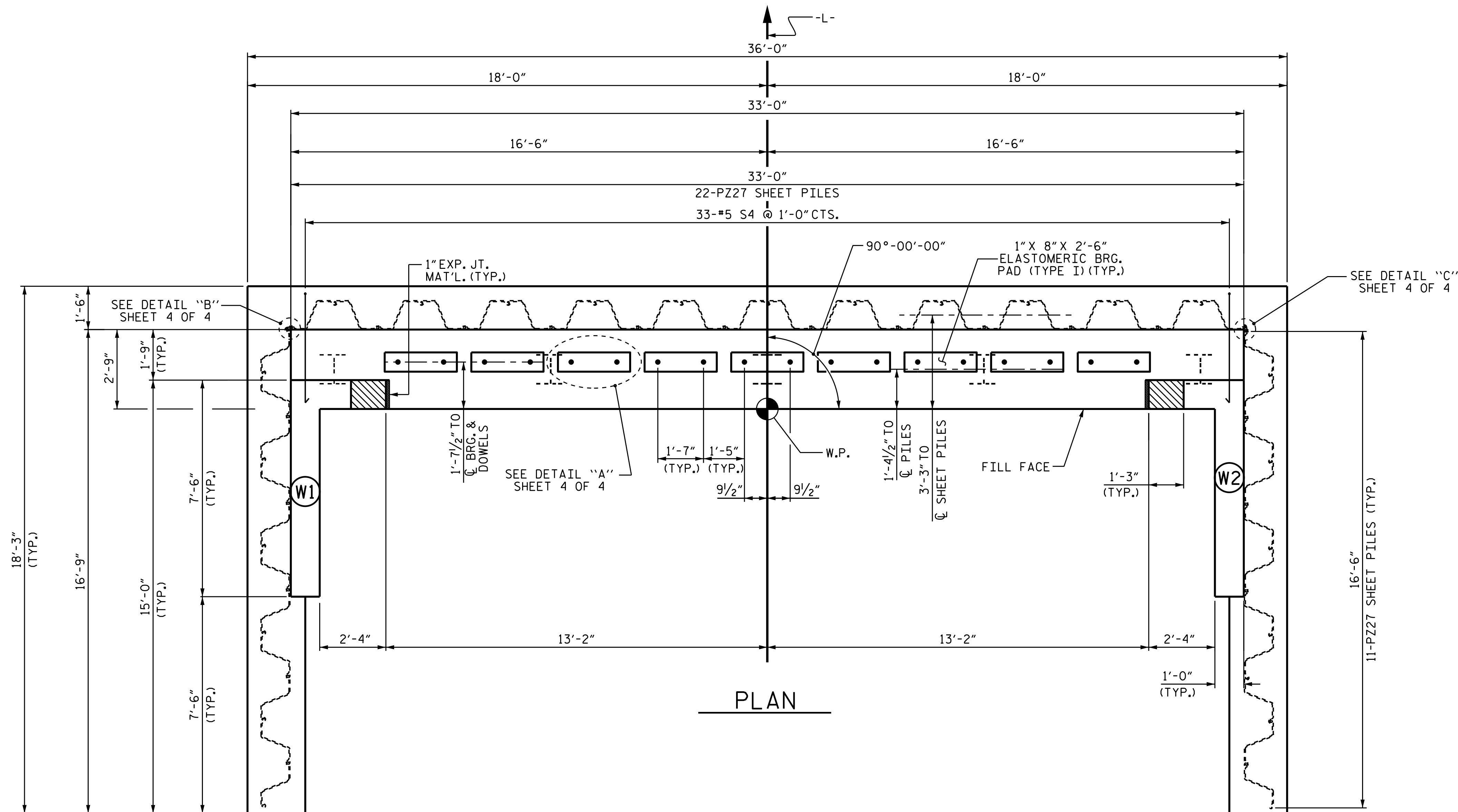

**PLAN**

TOP OF PILE ELEVATIONS	
①	949.99
②	949.84
③	949.69
④	949.54
⑤	949.39

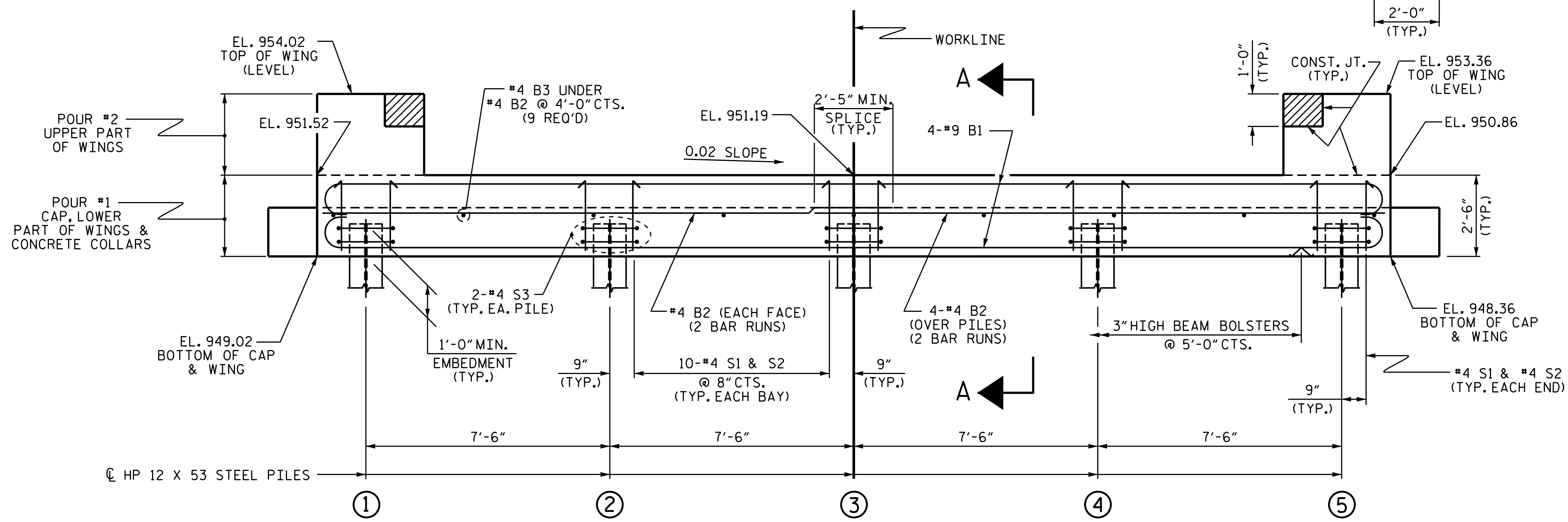

**ELEVATION**

WINGS & SHEET PILES NOT SHOWN FOR CLARITY. FOR SECTION A-A, SEE SHEET 4 OF 4.

PROJECT NO. B-5391  
ALEXANDER COUNTY  
 STATION: 14+56.30 -L-

SHEET 1 OF 4

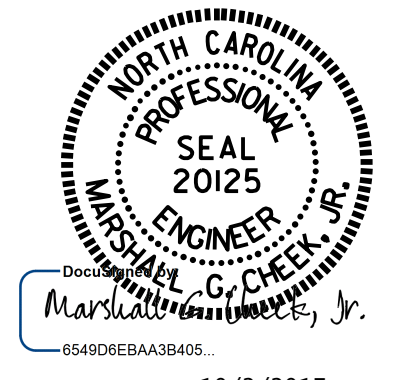

STATE OF NORTH CAROLINA  
 DEPARTMENT OF TRANSPORTATION  
 RALEIGH  
 SUBSTRUCTURE  
 END BENT No. 1

DRAWN BY : H. T. BARBOUR DATE : 5-19-17  
 CHECKED BY : M. G. CHEEK DATE : 8-17  
 DESIGN ENGINEER OF RECORD : H. A. LOCKLEAR DATE : 10-17

REVISIONS						SHEET NO.
NO.	BY:	DATE:	NO.	BY:	DATE:	S-8
1			3			TOTAL SHEETS
2			4			12

DOCUMENT NOT CONSIDERED FINAL UNLESS ALL SIGNATURES COMPLETED