

NOTES

- STIRRUPS IN CAP MAY BE SHIFTED AS NECESSARY TO CLEAR DOWELS.
- ★ INVERT ALTERNATE STIRRUPS.
- GALVANIZE THE TOP OF EACH INTERIOR BENT PILE A MINIMUM OF 25 FEET. GALVANIZE IN ACCORDANCE WITH SECTION 1076 OF THE STANDARD SPECIFICATIONS.

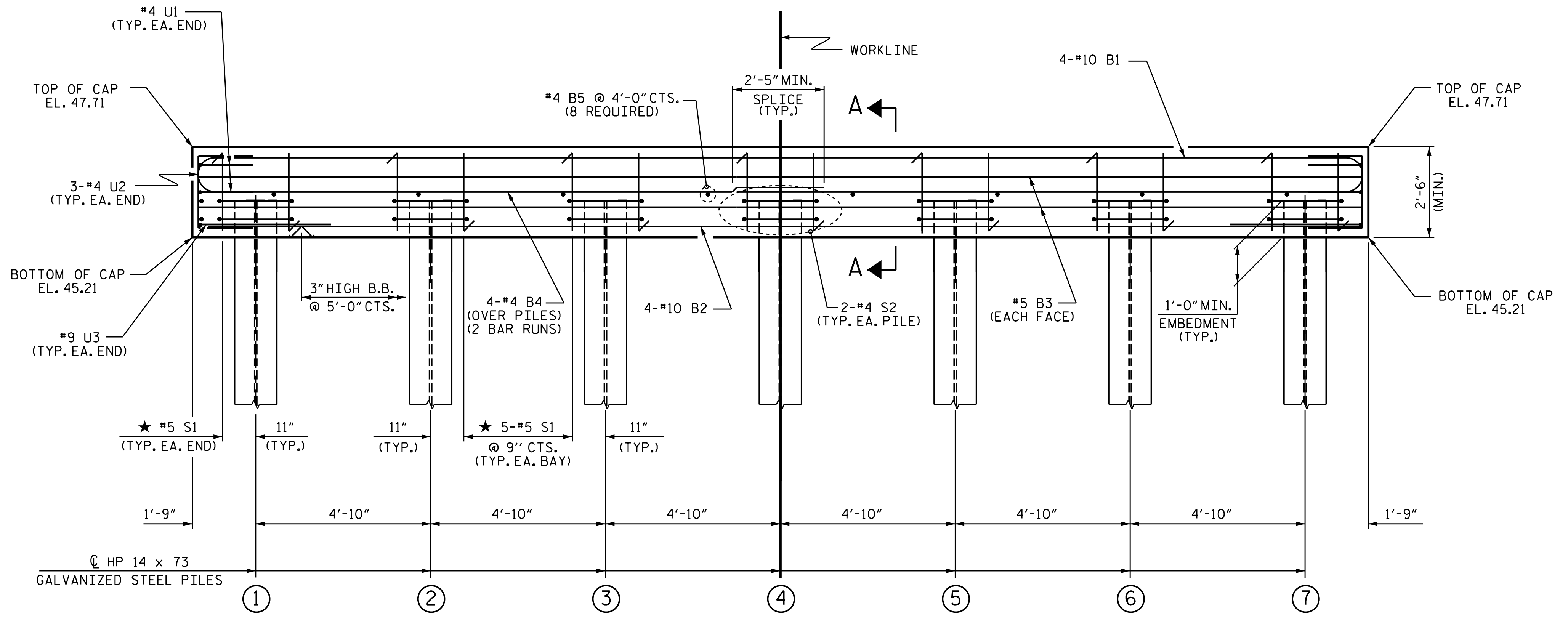
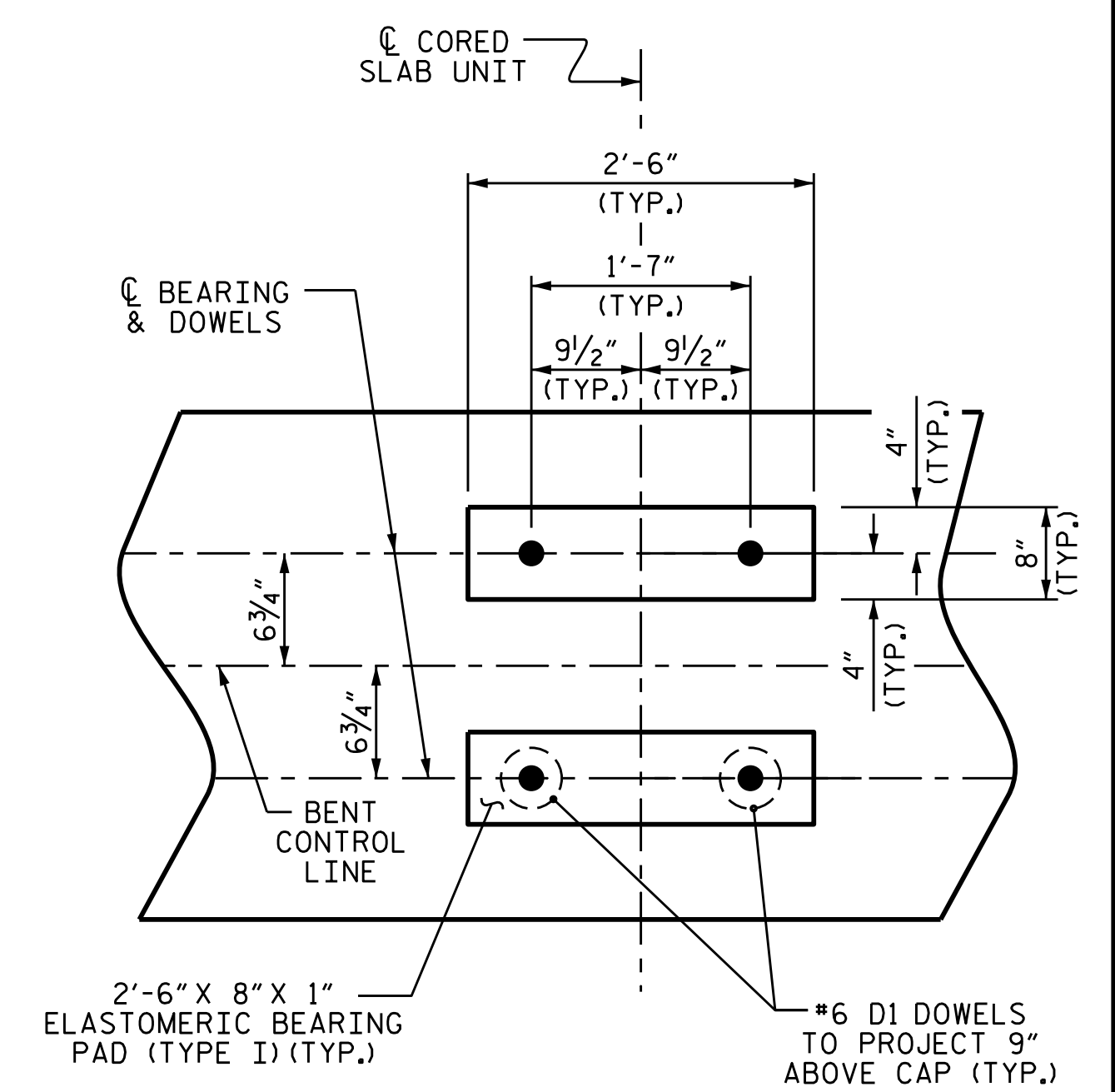
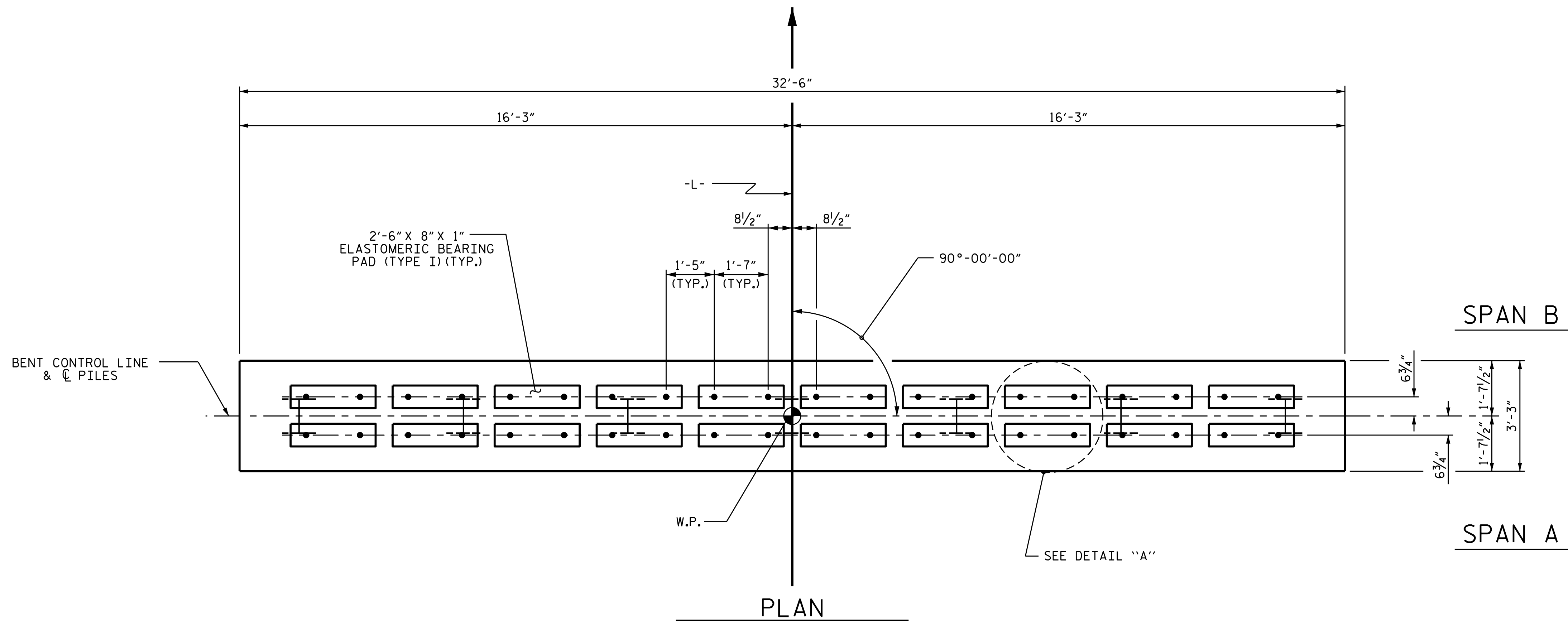

ELEVATION
 FOR SECTION A-A, SEE SHEET 3 OF 3

PROJECT NO. B-5304
PENDER COUNTY
 STATION: 12+27.00 -L-

SHEET 1 OF 3

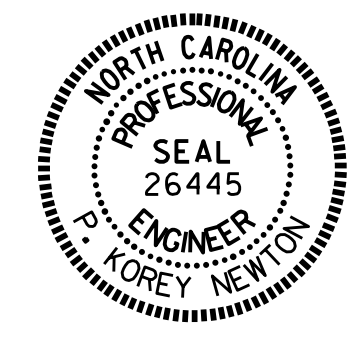

STATE OF NORTH CAROLINA
 DEPARTMENT OF TRANSPORTATION
 RALEIGH

SUBSTRUCTURE
 BENT No. 1

ASSEMBLED BY : G. KOUCHEKI	DATE : 10/16
CHECKED BY : J. D. HAWK	DATE : 8/10/17
DRAWN BY : DGE 05/10	REV. 11/14
CHECKED BY : MKT 05/10	MAA/TMG

REVISIONS						SHEET NO.	
NO.	BY:	DATE:	NO.	BY:	DATE:	S-21	
1			3			TOTAL SHEETS	25
2			4				

DOCUMENT NOT CONSIDERED FINAL UNLESS ALL SIGNATURES COMPLETED

26-SEP-2017 16:18
 J:\Structures\Plans\B5304_SMU_B*.dgn
 pknewton