

**ELEVATION**  
(CONCRETE BARRIER IN FRONT OF SOUND BARRIER WALL NOT SHOWN FOR CLARITY, SEE ROADWAY PLANS)

**SECTION A-A**  
(CONCRETE BARRIER IN FRONT OF SOUND BARRIER WALL NOT SHOWN FOR CLARITY, SEE ROADWAY PLANS)

PILE EXCAVATION DEPTHS "D"			
3'-0" Ø HOLE			
WALL -NW7- (STA. 10+00 TO 26+65 -NW7-)			
STATION	MAX WALL HEIGHT	PILE SPACING	SHAFT DEPTH
STA. 71+43.97 -L- TO STA. 72+86.92 -L-	13'-0"	15'-0"	14'-6"
STA. 72+97.68 -L- TO STA. 73+84.88 -L-	15'-0"	15'-0"	15'-6"
STA. 73+99.46 -L- TO STA. 88+48.25 -L-	17'-0"	15'-0"	13'-0"*

\* PILE EXCAVATION DEPTH ("D") FOR MSE WALL IS MEASURED FROM THE BOTTOM OF THE MSE WALL REINFORCED ZONE.

**NOTES:**  
 FOR SOUND BARRIER WALL, SEE SPECIAL PROVISIONS.  
 CONSTRUCT SOUND BARRIER WALL TO LINES AND GRADES SHOWN ON THE ROADWAY PLANS.  
 PROVIDE PANELS WITH A FLAT BOTTOM.  
 VERIFY THE LOCATION OF UNDERGROUND UTILITIES BEFORE DRILLING HOLES TO ENSURE SUFFICIENT CLEARANCE IS AVAILABLE.  
 ADJUST PILE EXCAVATION ELEVATIONS TO MAINTAIN 6" MINIMUM EMBEDMENT OF THE BOTTOM PANEL.  
 USE CLASS AA FOR PANELS AND CLASS A CONCRETE PILE EXCAVATION BACKFILL, IN ACCORDANCE WITH ARTICLE 1000-4 OF THE STANDARD SPECIFICATIONS.  
 FOR SOUND BARRIER WALL STATIONS, OFFSETS, AND WALL ENVELOPE, SEE ROADWAY PLANS.  
 PLACE 1" Ø BACKER RODS FULL HEIGHT ON EACH SIDE OF THE PRECAST PANELS, SET AND SEAL THE BACKER ROD IN PLACE WITH SEALANT THAT CONFORMS WITH ARTICLE 1028-3 OF THE STANDARD SPECIFICATIONS.  
 FOR SUBMITTAL OF WORKING DRAWINGS, SEE SPECIAL PROVISIONS.  
 FOR FALSEWORK AND FORMWORK, SEE SPECIAL PROVISIONS.  
 FOR ELASTOMERIC BEARING DETAILS, SEE "SOUND BARRIER WALL DETAILS" SHEET 1 OF 3.  
 FOR CONCRETE SHIM BLOCK DETAILS, SEE "SOUND BARRIER WALL DETAILS" SHEET 1 OF 3.  
 FOR PRECAST PANEL DETAILS, SEE "SOUND BARRIER WALL DETAILS" SHEET 1 OF 3.  
 FOR CONCRETE PILE DETAILS, SEE "SOUND BARRIER WALL DETAILS" SHEETS 1 & 2 OF 3.  
 DUE TO THE SHALLOW GROUNDWATER TABLE, UNSTABLE OR CAVING SOILS ARE ANTICIPATED AND TEMPORARY STEEL CASING OR SLURRY IS ANTICIPATED TO STABILIZE THE PILE EXCAVATIONS IN ACCORDANCE WITH THE REQUIREMENTS IN THE SOUND BARRIER WALL SPECIAL PROVISION.  
 NOTE THAT SOUND BARRIER WALL PILES LOCATED WITHIN THE MSE WALL BACKFILL MUST BE INSTALLED PRIOR TO MSE WALL CONSTRUCTION. THE EMBEDMENT DEPTH PROVIDED IS MEASURED BELOW THE BASE OF THE MSE WALL AND DOES NOT INCLUDE THE LENGTH THROUGH THE REINFORCED ZONE.  
 AT THE CONTRACTOR'S OPTION, USE CONTINUOUS FLIGHT AUGER PILES IN LIEU OF PILE EXCAVATION FOR SOUND BARRIER WALL FOUNDATION. SEE "CONTINUOUS FLIGHT AUGER PILES FOR SOUND BARRIER WALLS" SPECIAL PROVISION.  
 THE ARCHITECTURAL CONCRETE SURFACE TREATMENT SHALL MATCH THE APPEARANCE (STONE SIZE AND SHAPE, STONE TEXTURE, PATTERN AND RELIEF) OF NATURAL STONE TO RESEMBLE A DRY STACKED STONE PATTERN WITH FEDERAL STANDARD 595 COLOR \* FS30450 STAIN.

**EXPOSURE CATEGORY D - PILE REINFORCING STEEL**

DESIGN WIND PRESSURE = 62 PSF (0' < H ≤ 14'); 71 PSF (14' < H ≤ 25')

PILE TYPE I				PILE TYPE III			
PILE SPACING	MAXIMUM WALL HEIGHT (H)	VERTICAL REINFORCING STEEL	TIES	PILE SPACING	MAXIMUM WALL HEIGHT (H)	VERTICAL REINFORCING STEEL	TIES
15'-0"	H ≤ 15'	4 - #8 EA. FACE	#3 @ 11" CTS.	15'-0"	H ≤ 15'	3 - #9 SHORT FACE 4 - #9 LONG FACE	#3 @ 11" CTS.
15'-0"	15' < H ≤ 20'	4 - #10 EA. FACE	#3 @ 10" CTS.	15'-0"	15' < H ≤ 20'	3 - #11 SHORT FACE 4 - #11 LONG FACE	#3 @ 10" CTS.

PILE TYPE II				PILE TYPE III ALT.			
PILE SPACING	MAXIMUM WALL HEIGHT (H)	VERTICAL REINFORCING STEEL	TIES	PILE SPACING	MAXIMUM WALL HEIGHT (H)	VERTICAL REINFORCING STEEL	TIES
15'-0"	H ≤ 15'	4 - #6 EA. FACE	#3 @ 11" CTS.	15'-0"	H ≤ 15'	3 - #9 SHORT FACE 4 - #9 LONG FACE	#3 @ 11" CTS.
15'-0"	15' < H ≤ 20'	4 - #8 EA. FACE	#3 @ 10" CTS.	15'-0"	15' < H ≤ 20'	3 - #11 SHORT FACE 4 - #11 LONG FACE	#3 @ 10" CTS.

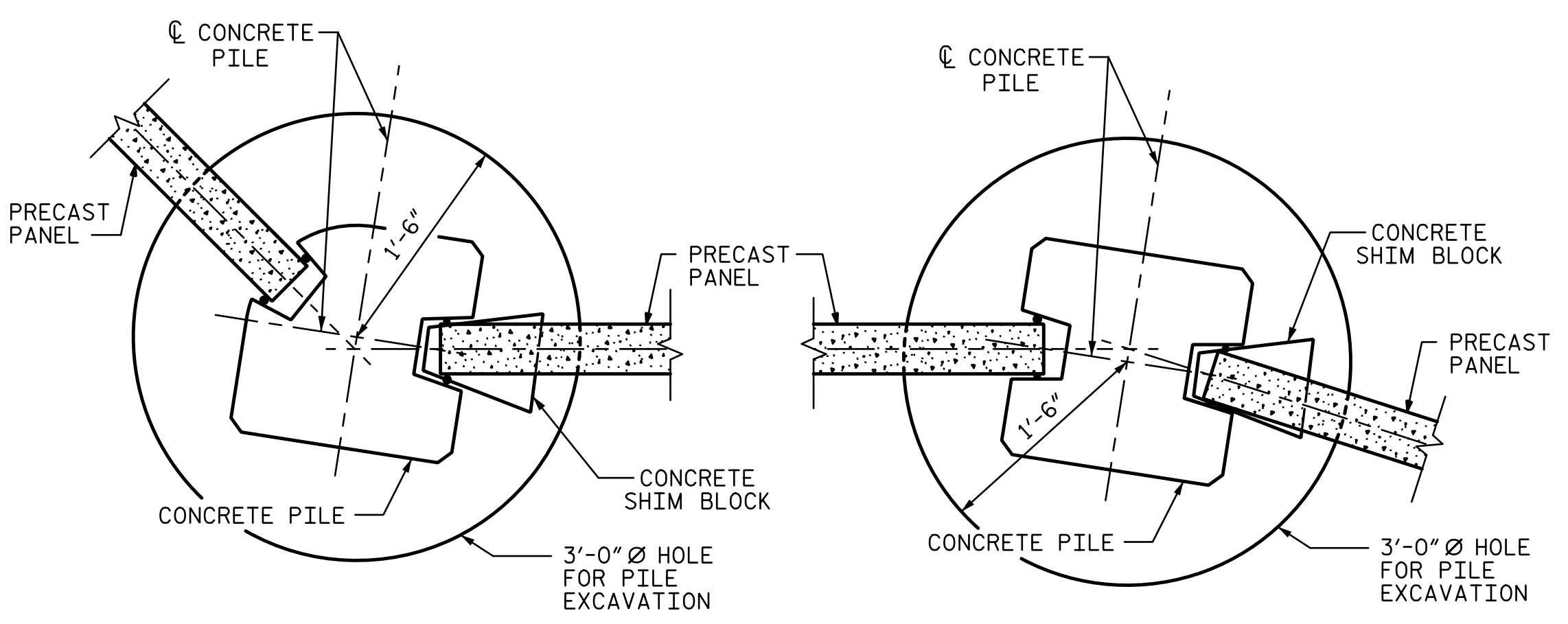

**TYPICAL WALL TURN DETAILS**

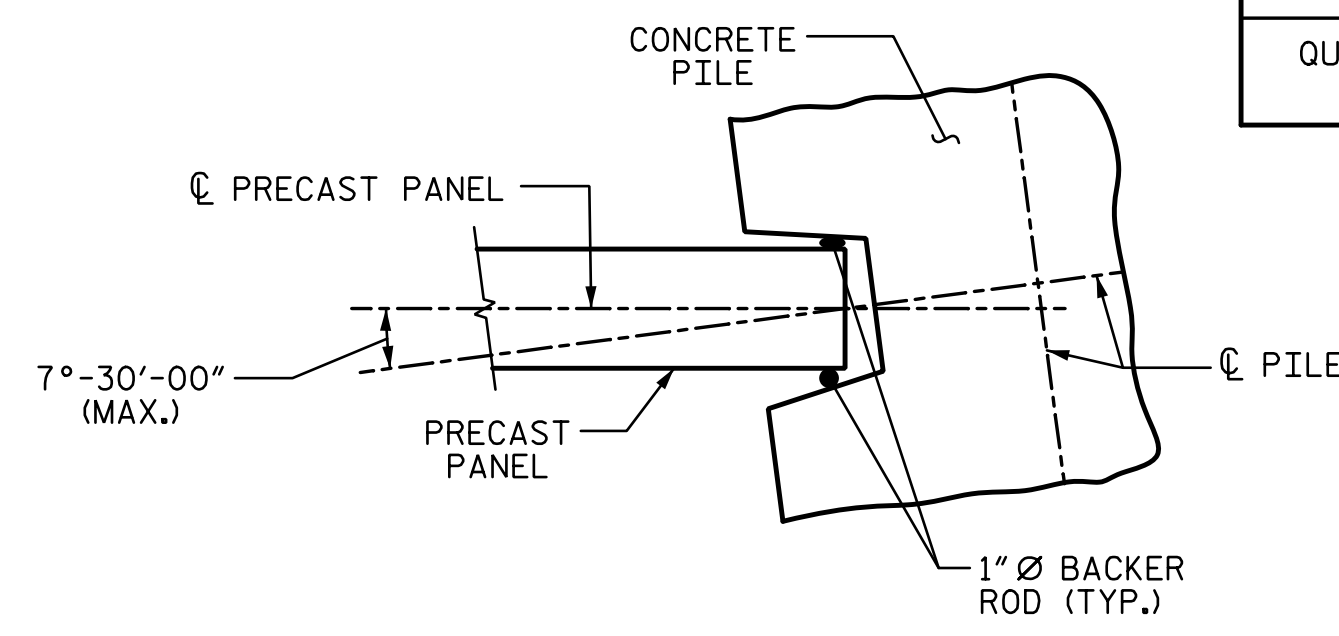

**PILE ROTATION LIMIT FOR WALL TURN**

(ROTATE THE CONCRETE PILE ±7°-30'-00" MAX. TO ACCOMMODATE WALL TURN.)

BILL OF MATERIAL -NW7-	
SOUND BARRIER WALL	S.F. 25,447
ARCHITECTURAL SURFACE TREATMENT	{S.F. 42,764}
QUANTITIES PROVIDED ARE APPROXIMATE AND ARE FOR BID PURPOSES ONLY.	

△ REVISED ARCHITECTURAL SURFACE TREATMENT QUANTITY  
**PROJECT NO. U-4751**  
**NEW HANOVER COUNTY**  
**STATION: 71+43.97 -L- = 10+00.00 -NW7-**

STATE OF NORTH CAROLINA  
 DEPARTMENT OF TRANSPORTATION  
 RALEIGH

**SOUND BARRIER WALL NO. -NW7-**

10/10/2017

STV ENGINEERS, INC.  
 900 West Trade St., Suite 715  
 Charlotte, NC 28202  
 NC License Number F-5991

REVISIONS						SHEET NO.
NO.	BY:	DATE:	NO.	BY:	DATE:	NW-4
1	STV	10-17	3			TOTAL SHEETS 17
2			4			

10/10/2017 3:39:22 PM R:\noisewalls\NW 7-420\_001\_U4751\_SMLL\_NW\_001\_640007.dgn