

NOTES

APPROACH SLAB SHALL NOT BE CONSTRUCTED PRIOR TO COMPLETION OF THE BRIDGE DECK.

FOR REINFORCED BRIDGE APPROACH FILL INCLUDING GEOTEXTILE, IMPERMEABLE GEOMEMBRANE, 4" Ø DRAINAGE PIPE, #78M STONE, AND SELECT MATERIAL, SEE ROADWAY PLANS.

AREA BETWEEN THE WINGWALL AND APPROACH SLAB SHALL BE GRADED TO DRAIN THE WATER AWAY FROM THE FILL FACE OF THE BRIDGE AND SHALL BE PAVED. SEE ROADWAY PLANS.

FOR EXPANSION JOINT SEALS, SEE SPECIAL PROVISIONS.

FOR CONCRETE ISLAND REINFORCEMENT AND DETAILS, SEE "MONOLITHIC CONCRETE ISLAND" SHEET.

BILL OF MATERIAL

APPROACH SLAB AT EB 1					
BAR	NO.	SIZE	TYPE	LENGTH	WEIGHT
*A1	125	#4	STR	28'-5"	2,373
A2	130	#4	STR	28'-3"	2,453
*B1	233	#5	STR	23'-8"	5,751
B2	233	#6	STR	24'-7"	8,603
*B3	4	#5	STR	10'-0"	42
B4	4	#6	STR	10'-0"	60
*J1	132	#4	1	1'-5"	125
REINFORCING STEEL **					LBS. 11,116
*EPOXY COATED REINFORCING STEEL **					LBS. 8,291
CLASS AA CONCRETE **					C. Y. 127.1
APPROACH SLAB AT EB 2					
BAR	NO.	SIZE	TYPE	LENGTH	WEIGHT
*A1	125	#4	STR	28'-5"	2,373
A2	130	#4	STR	28'-3"	2,453
*B1	233	#5	STR	23'-8"	5,751
B2	233	#6	STR	24'-7"	8,603
*B3	4	#5	STR	10'-0"	42
B4	4	#6	STR	10'-0"	60
*J1	132	#4	1	1'-5"	125
REINFORCING STEEL **					LBS. 11,116
*EPOXY COATED REINFORCING STEEL **					LBS. 8,291
CLASS AA CONCRETE **					C. Y. 127.1
BAR TYPE					

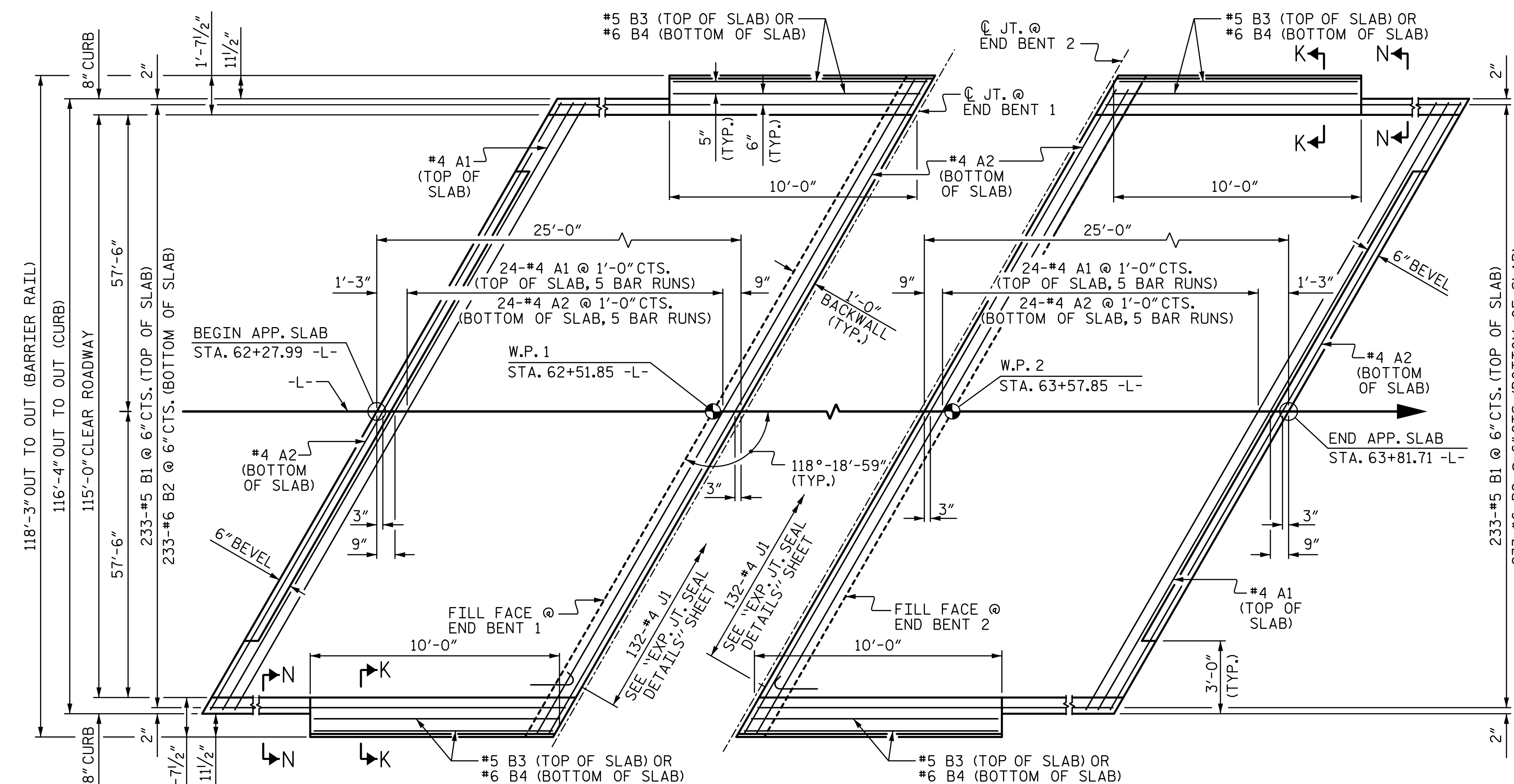

SPlice LENGTHS		
BAR SIZE	EPOXY COATED	UNCOATED
#4	2'-0"	1'-9"
#5	2'-6"	2'-2"
#6	3'-10"	2'-7"

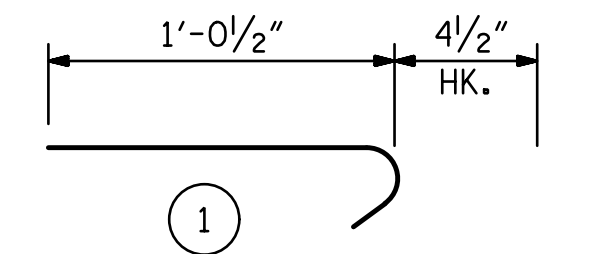

ALL BAR DIMENSIONS ARE OUT TO OUT
** QUANTITIES FOR BARRIER RAIL ARE NOT INCLUDED. SEE SHEET 2 OF 2.

THE QUANTITY OF #4 J1 BARS ON THE BILL OF MATERIAL IS BASED ON 1'-0" CENTERS. J1 BARS SHALL BE PLACED AT EACH VERTICAL STUD ANCHOR BOLT. IN THE EVENT THAT THE NUMBER OF VERTICAL STUD ANCHORS EXCEEDS THE NUMBER OF J1 BARS SPECIFIED, ADDITIONAL J1 BARS WILL NOT BE REQUIRED.

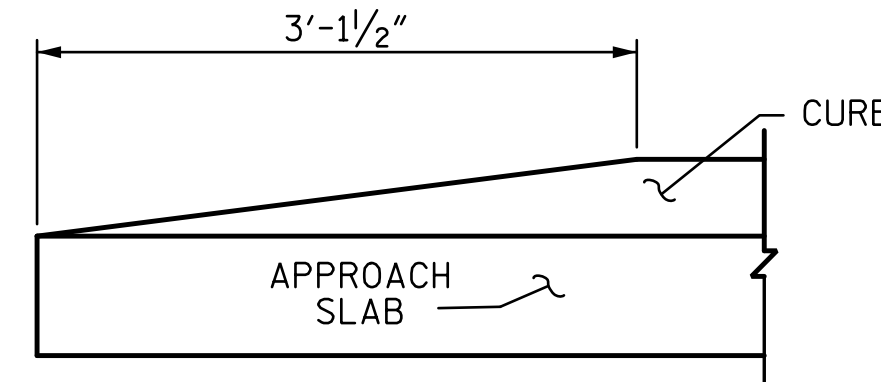
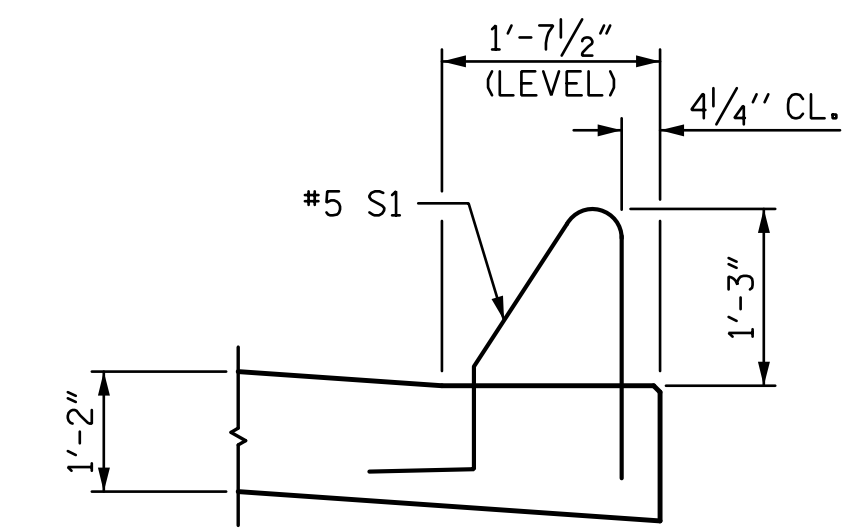
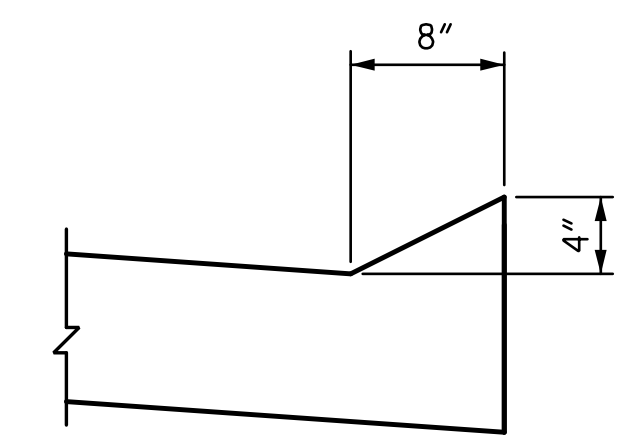
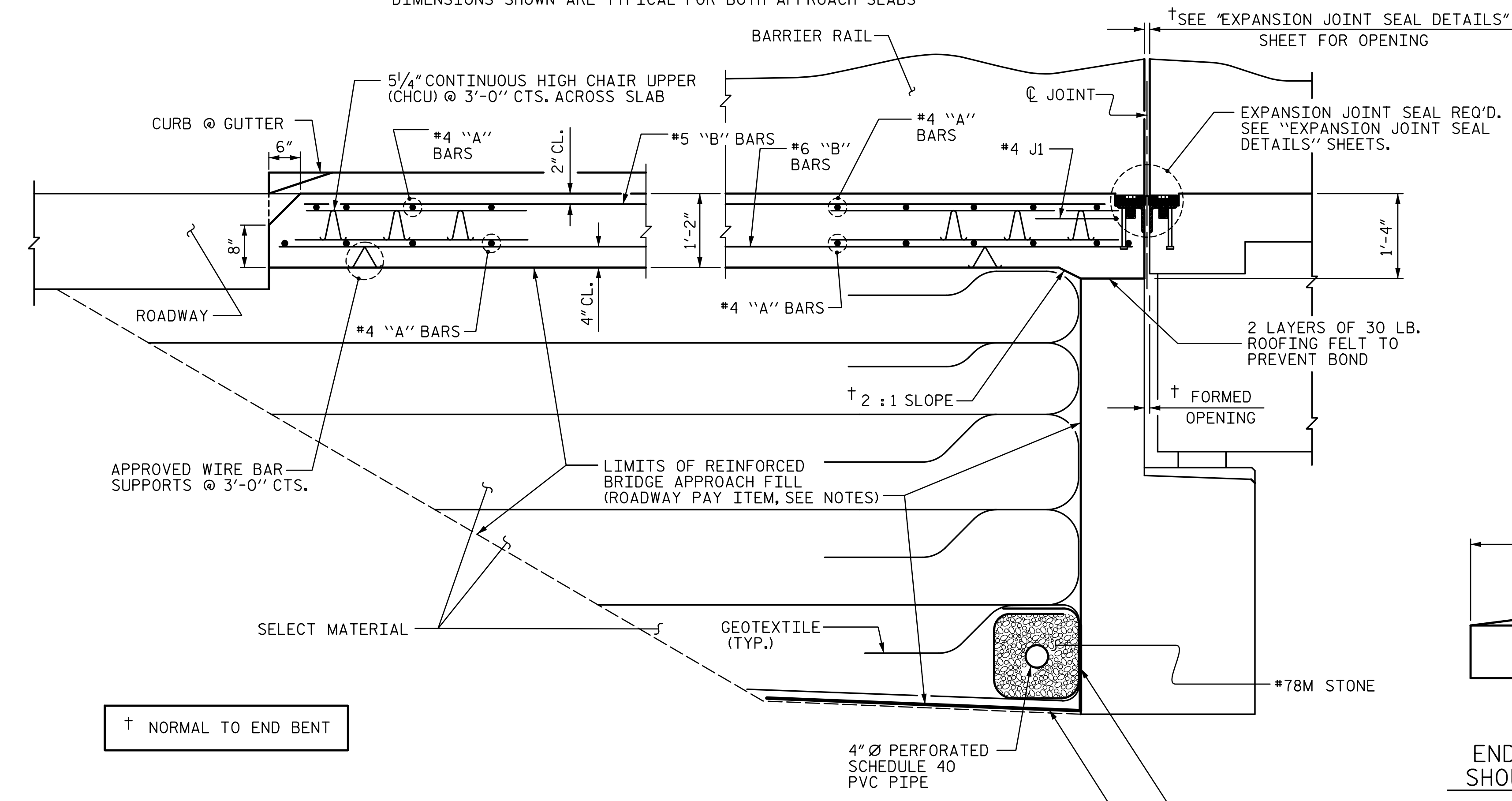

PROJECT NO. U-4751
NEW HANOVER COUNTY
 STATION: 62+99.10 -L-
 SHEET 1 OF 2

STATE OF NORTH CAROLINA
 DEPARTMENT OF TRANSPORTATION
 RALEIGH

BRIDGE APPROACH SLAB

STV ENGINEERS, INC.
 900 West Trade St., Suite 715
 Charlotte, NC 28202
 NC License Number F-5991

6/29/2017

REVISIONS				SHEET NO.
NO.	BY:	DATE:	NO.	DATE:
1			3	
2			4	

TOTAL SHEETS: 30

R:\402_057_U4751_SML_AS_029_640202.dgn
 6/27/2017 14:01:46
 TOWNSEND

DRAWN BY: TJT DATE: 3-17
 CHECKED BY: AJP DATE: 4-17
 DESIGN ENGINEER OF RECORD: T. TOWNSEND DATE: 3-17