

**TRANSVERSE CONSTRUCTION JOINT DETAIL**

NOTE: REINFORCING STEEL IN SLAB NOT SHOWN. LONGITUDINAL REINFORCING STEEL SHALL BE CONTINUOUS THROUGH JOINT.

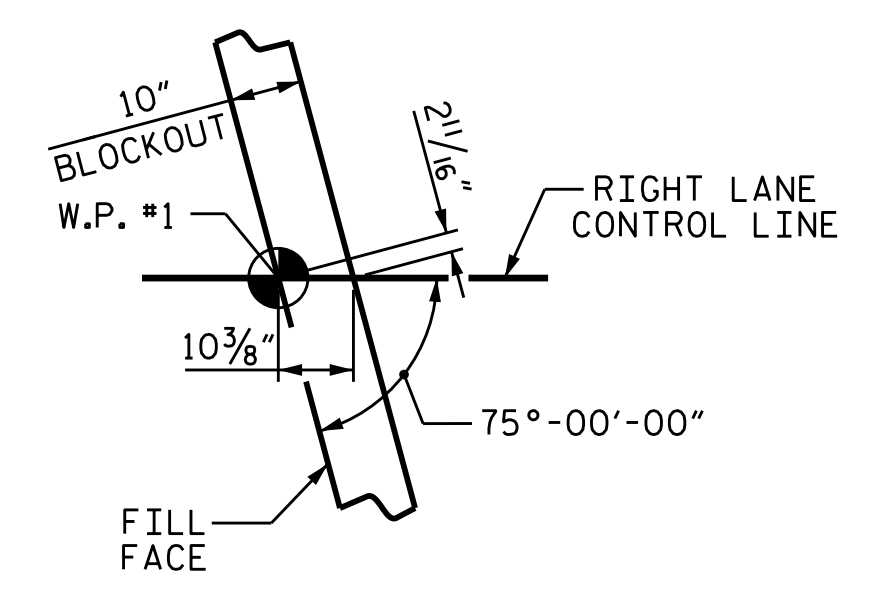

**DETAIL "A"**

PROJECT NO. U-2579C  
FORSYTH COUNTY  
 STATION: 473+70.00 -L-

SHEET 1 OF 3

STATE OF NORTH CAROLINA  
 DEPARTMENT OF TRANSPORTATION  
 RALEIGH

**SUPERSTRUCTURE**  
**PLAN OF SPAN A**  
 (RIGHT LANE)

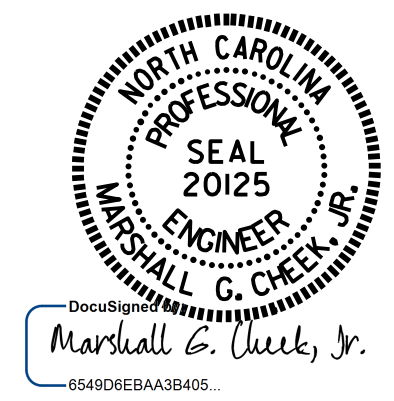

7/27/2017

REVISIONS						SHEET NO.	
NO.	BY:	DATE:	NO.	BY:	DATE:	S4-7	
1			3			TOTAL SHEETS	
2			4			33	

DRAWN BY: J. K. BOWLES DATE: 4/7/16  
 CHECKED BY: K. D. LAYNE DATE: 6/15/16  
 DESIGN ENGINEER OF RECORD: H. A. LOCKLEAR DATE: 6/2017

**PLAN OF SPAN A**  
 INTERMEDIATE STEEL DIAPHRAGMS NOT SHOWN FOR CLARITY. FOR DETAILS, SEE "INTERMEDIATE STEEL DIAPHRAGMS FOR PRESTRESSED CONCRETE GIRDERS" SHEET.  
 \* 2 BAR RUNS FOR A101 THROUGH A103 & A201 THROUGH A203.

DOCUMENT NOT CONSIDERED FINAL UNLESS ALL SIGNATURES COMPLETED