

PLAN OF FLOOR SLAB

#6 S1 BARS IN OUTLET WINGS SHALL BE PLACED AS PART OF STAGE I.
SEE SHEET 6 OF 8 FOR S1 BAR DETAILS AND QUANTITIES.
C2 BARS SHALL BE FIELD BENT AS NECESSARY.

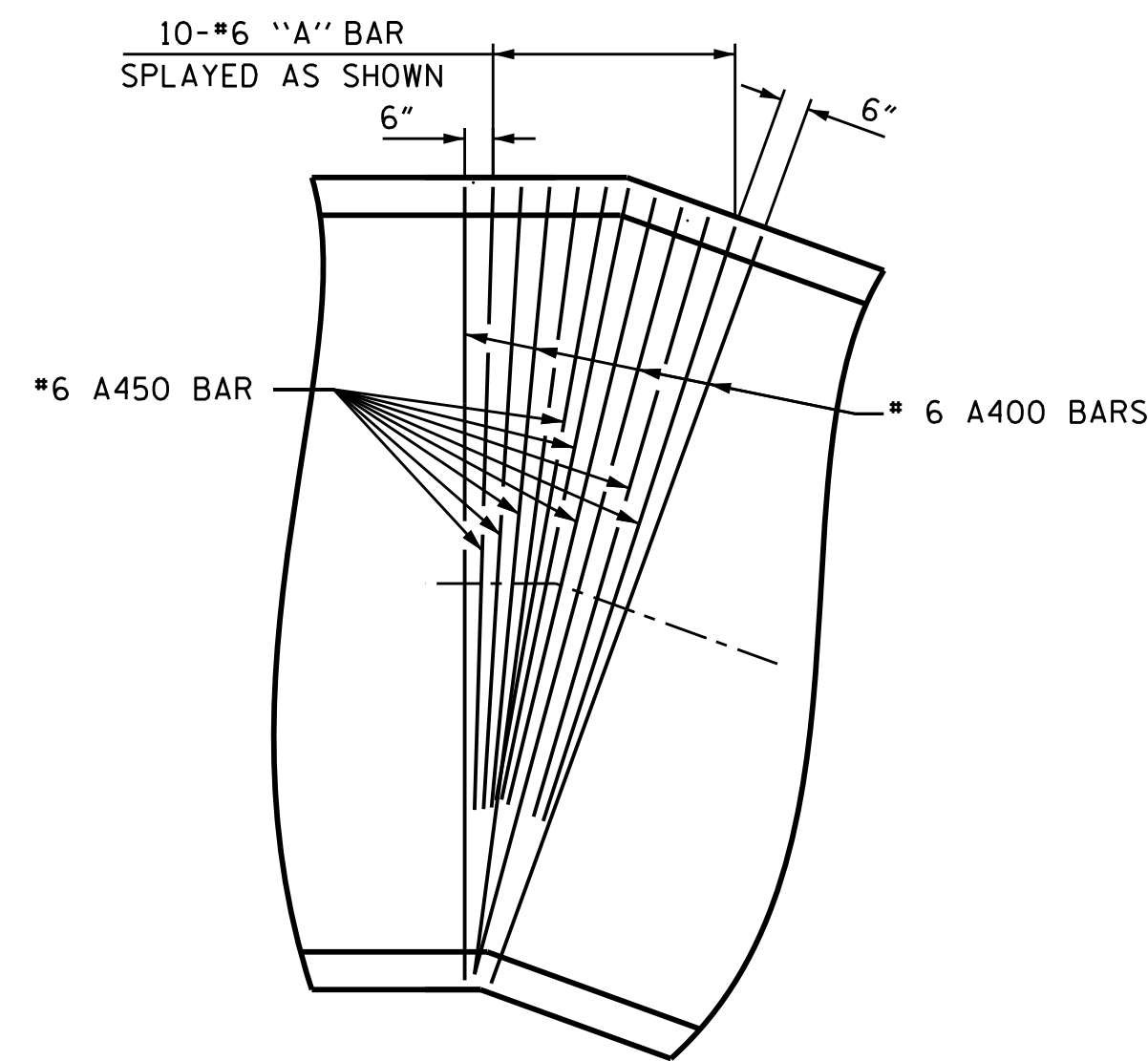

DETAIL A

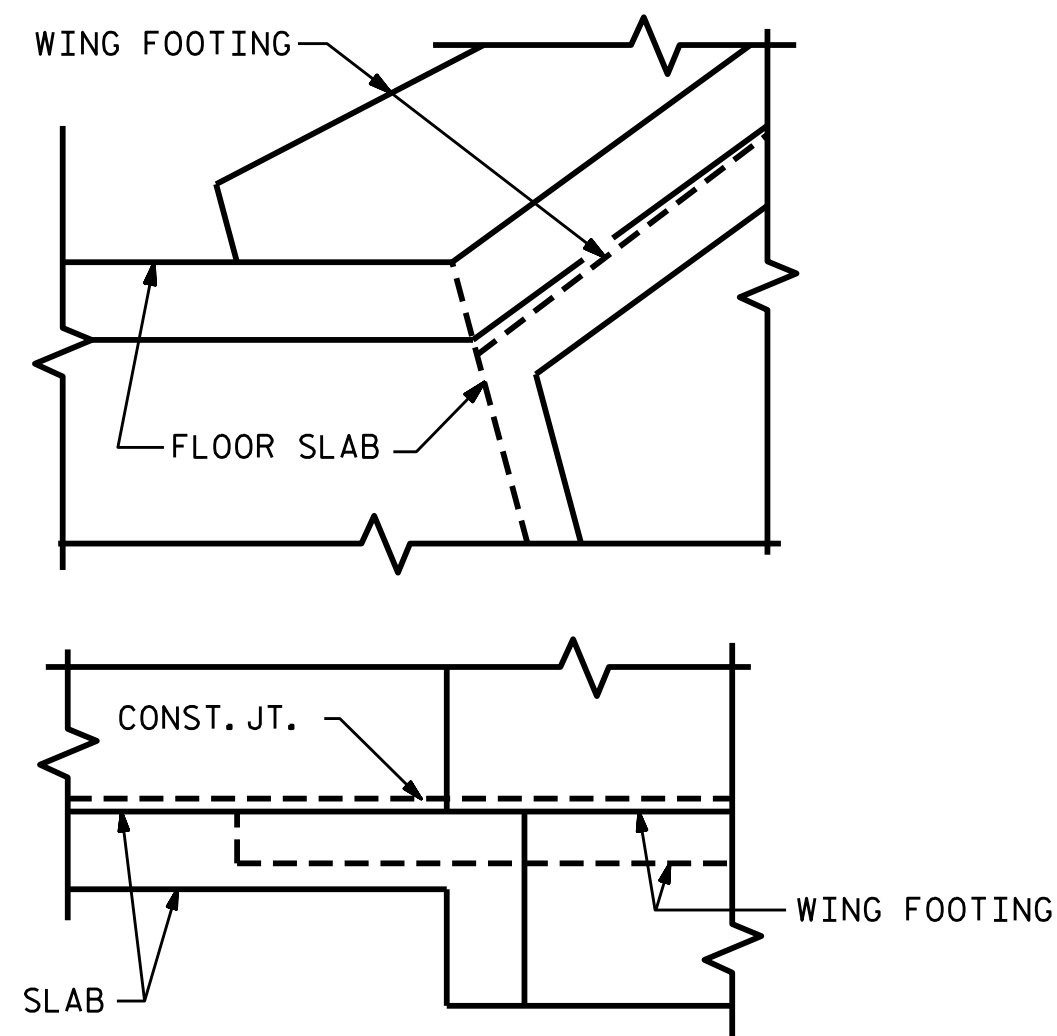

DETAIL
CONNECTION OF WING FOOTING AND FLOOR SLAB WHEN SLAB IS THICKER THAN FOOTING

PROJECT NO. B-5347
ALAMANCE COUNTY
STATION: 14+14.00 -L-
SHEET 4 OF 8

STATE OF NORTH CAROLINA
DEPARTMENT OF TRANSPORTATION
RALEIGH
SINGLE 13' X 7'
CONCRETE BOX CULVERT
FLOOR SLAB DETAILS



DocuSigned by:
K.W. Alford
72459389206P40E
9/25/2017

DRAWN BY : K.W. ALFORD DATE : 3/17
CHECKED BY : J.D. HAWK DATE : 3/17
DESIGN ENGINEER OF RECORD: K.W. ALFORD DATE : 3/17

DOCUMENT NOT CONSIDERED
FINAL UNLESS ALL
SIGNATURES COMPLETED

REVISIONS						SHEET NO.
NO.	BY:	DATE:	NO.	BY:	DATE:	C-4
1			3			TOTAL SHEETS
2			4			8