

TYPICAL SECTION NO. 1

MAP NO. 1  
NC 50 (S.N. ANDERSON BLVD.)  
MP 0.000 – MP 3.962

MAP NO. 2  
NC 210  
MP 5.520 – MP 6.531

NOTES: MILL A SINGLE LANE AND PAVE BACK BY THE END OF EACH WORK DAY.

SHOULDER WORK ON MAP NO.1 AS NEEDED, TO BE DETERMINED BY ENGINEER.

SHOULDER WORK ON MAP NO.2 AS NEEDED, TO BE DETERMINED BY ENGINEER. USE AGGREGATE SHOULDER BORROW (ASB) ONLY.

PAVEMENT SCHEDULE	
C1	PROP. APPROX. 1½" DEPTH ASPHALT CONCRETE SURFACE COURSE, TYPE S9.5B, AT AN AVERAGE RATE OF 168 LBS. PER SQ.YD.
C2	PROP. APPROX. 2" DEPTH ASPHALT CONCRETE SURFACE COURSE, TYPE S9.5B, AT AN AVERAGE RATE OF 224 LBS. PER SQ.YD.
C3	PROP. APPROX. 1½" DEPTH ASPHALT CONCRETE SURFACE COURSE, TYPE SF9.5A, AT AN AVERAGE RATE OF 165 LBS. PER SQ.YD.
C4	PROP. APPROX. ¾" DEPTH ASPHALT CONCRETE SURFACE COURSE, TYPE S4.75A, AT AN AVERAGE RATE OF 85 LBS. PER SQ.YD.
D1	PROP. APPROX. 3" DEPTH ASPHALT CONCRETE INTERMEDIATE COURSE, TYPE I19.0B, AT AN AVERAGE RATE OF 342 LBS. PER SQ.YD.
E1	PROP. APPROX. 5" DEPTH ASPHALT CONCRETE BASE COURSE, TYPE B25.0B, AT AN AVERAGE RATE OF 570 LBS. PER SQ.YD.
E2	PROP. APPROX. 4" DEPTH ASPHALT CONCRETE BASE COURSE, TYPE B25.0B, AT AN AVERAGE RATE OF 456 LBS. PER SQ.YD.
R1	EXISTING CONCRETE 2'-6" CURB & GUTTER
R2	EXISTING CONCRETE BRIDGE RAIL
T	SHOULDER CONSTRUCTION
U	EXISTING PAVEMENT
V1	MILLING ASPHALT PAVEMENT, 1½" DEPTH

PAVEMENT EDGE SLOPES ARE 1:1, EXCEPT FINAL SURFACE COURSE. SEE SHOULDER WEDGE DETAIL.

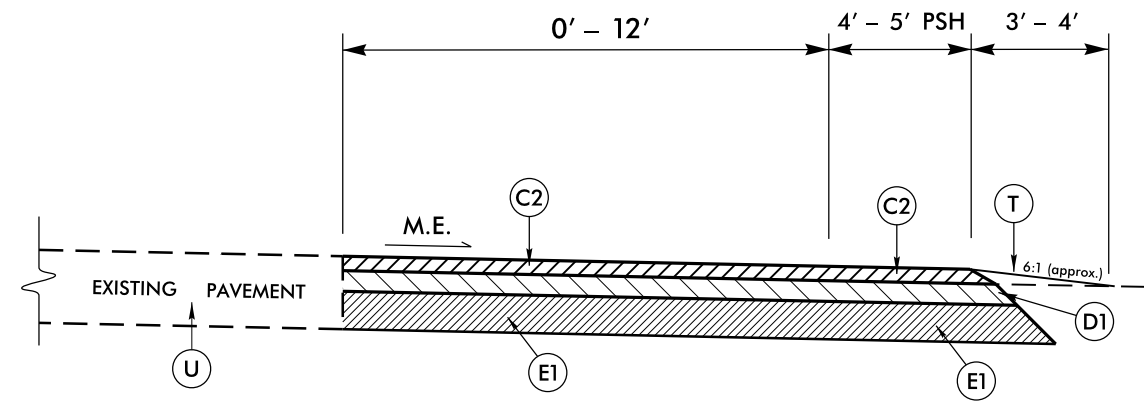

TYPICAL SECTION NO. 2

MAP NO. 3  
US 17 (RT. LANE TURN EXTENSION)  
MP 13.642 – MP 13.702

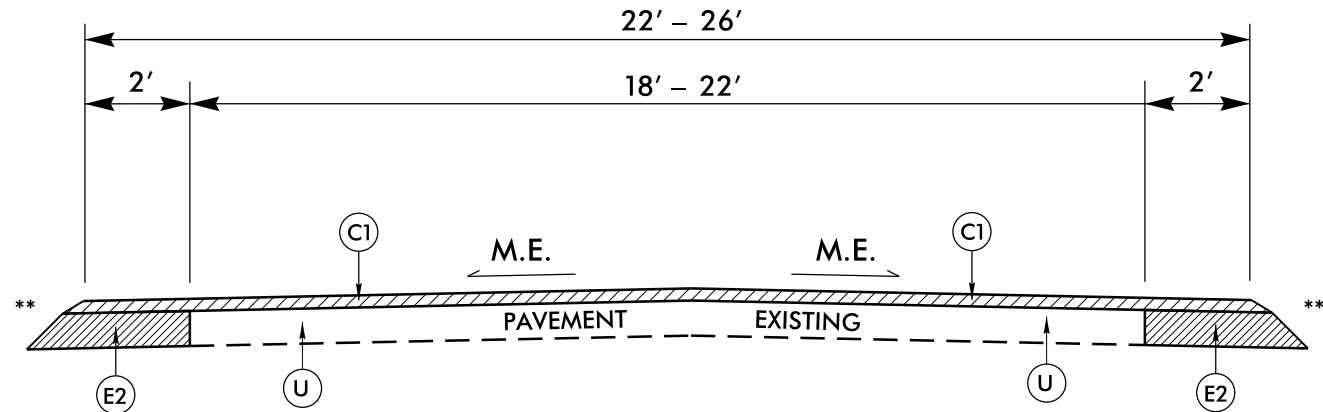

TYPICAL SECTION NO. 3

MAP NO. 4  
SR 1565 (COUNTRY CLUB RD.)  
MP 0.000 – MP 2.460  
1.5" MILLING: C&G TURN LANE

MAP NO. 16  
SR 1533 (SHEPARD'S RD.)  
MP 0.000 – MP 1.220

NOTE: SHOULDER WORK TO BE DONE BY STATE FORCES (MAP NO. 4 & 16).

8/17/99  
 REVISIONS  
 24-AUG-2017 14:45  
 S:\Contracts\2018\2018CPT\03\05\10711\etc\rdy\_tup.dgn  
 2018CPT.03.05.10711.etc.rdy\_tup.dgn