

PROJECT REFERENCE NO. <i>U-2579C</i>	SHEET NO. <i>2D-2</i>
RW SHEET NO.	
HYDRAULICS ENGINEER	

DOCUMENT NOT CONSIDERED FINAL UNLESS ALL SIGNATURES COMPLETED

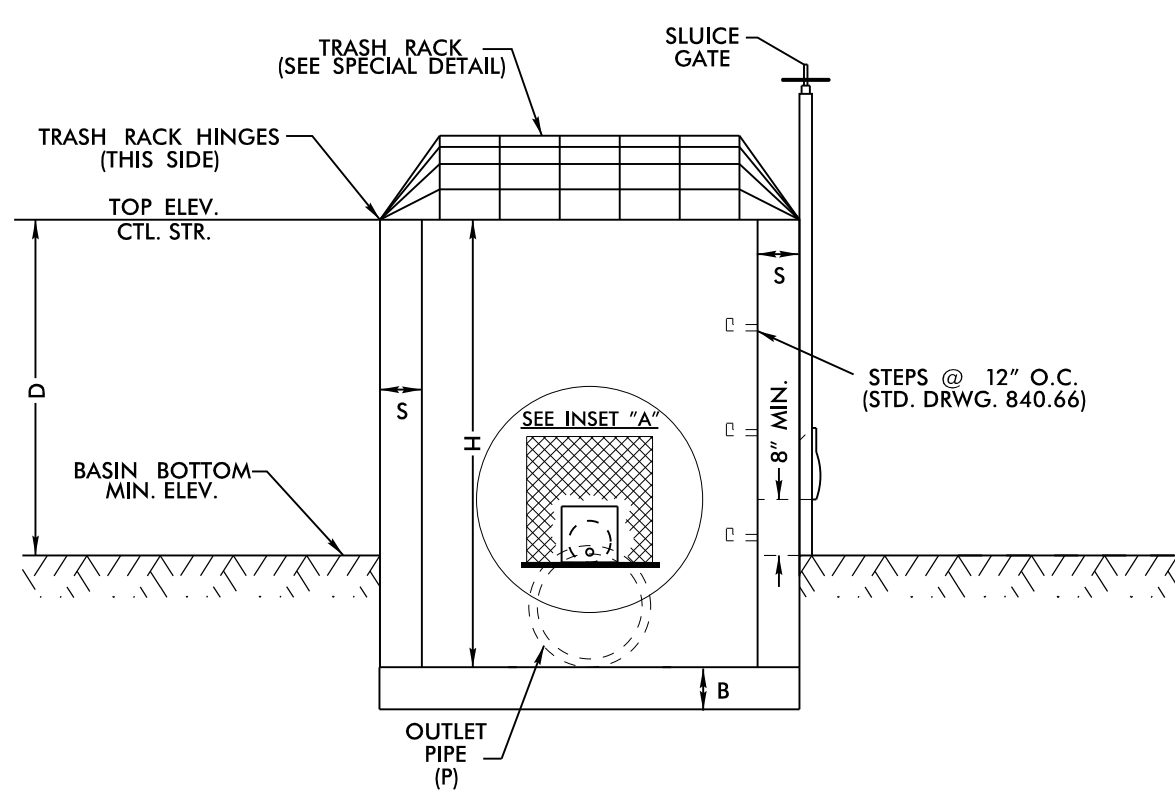

DETAIL EE
DRY DETENTION BASIN DRAWDOWN STRUCTURE
NOT TO SCALE



SIDE 1

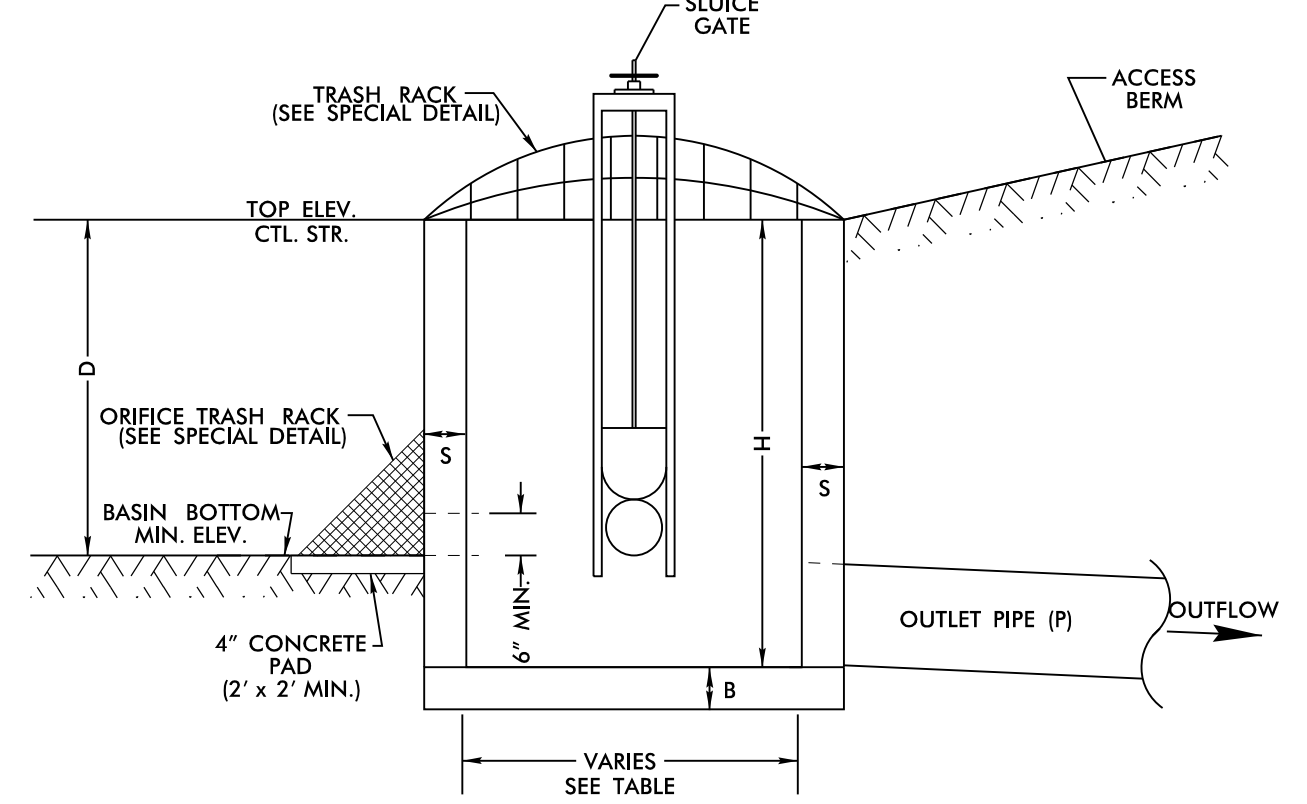

SIDE 2

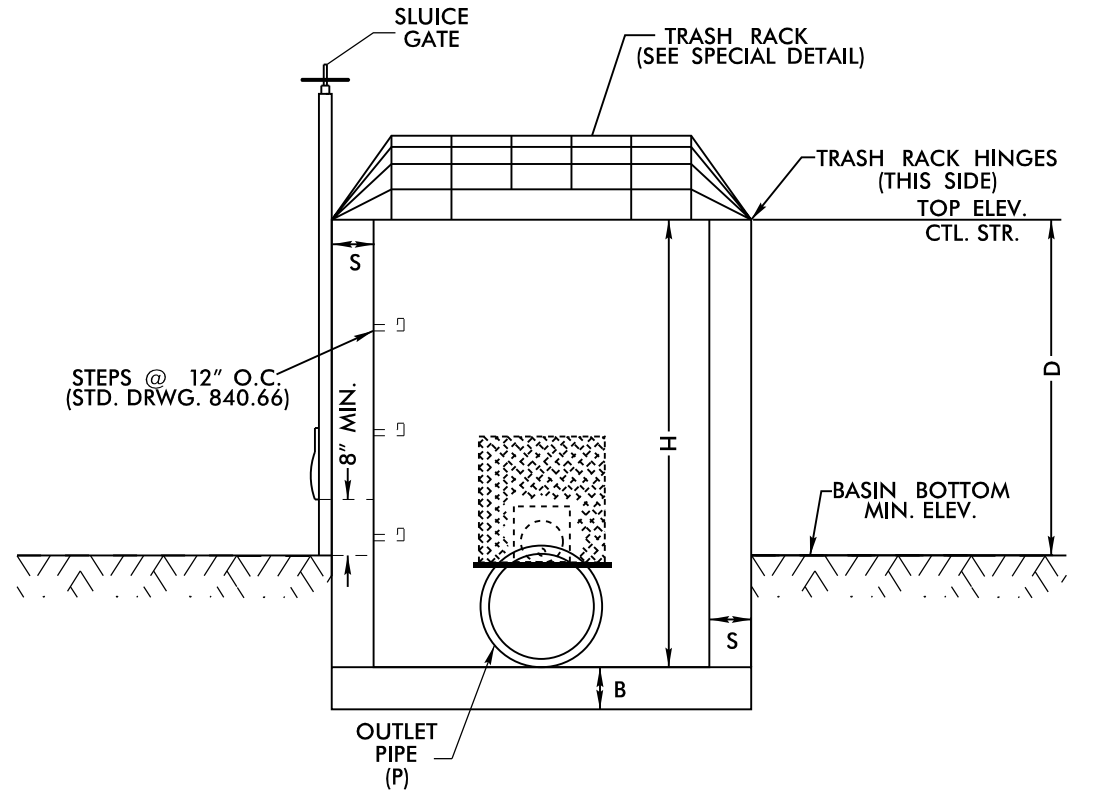

SIDE 3

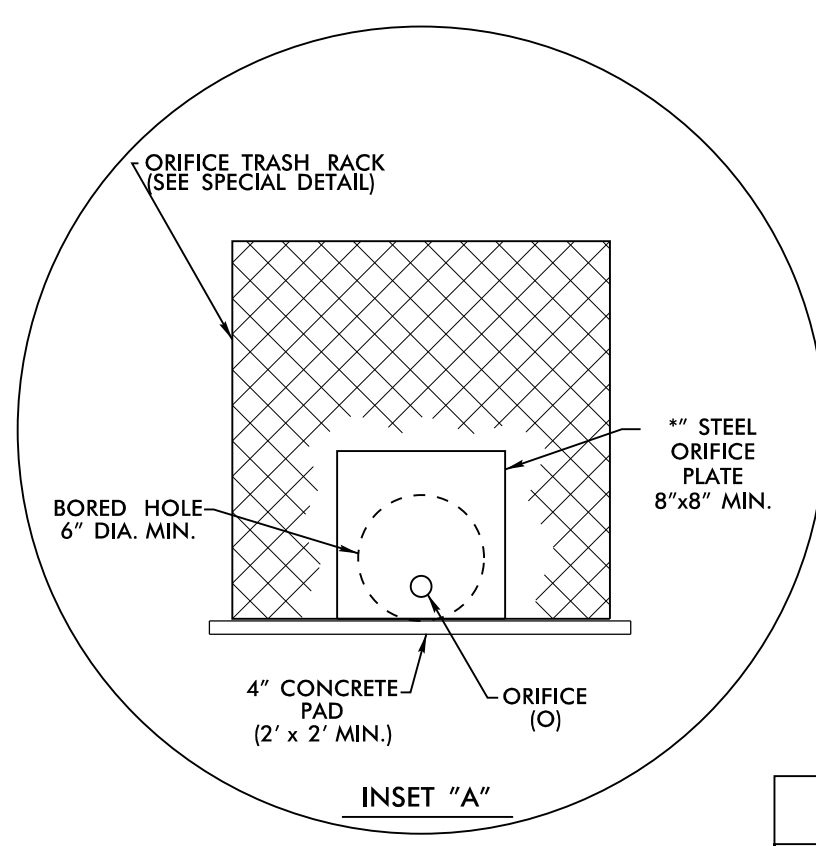

INSET "A"

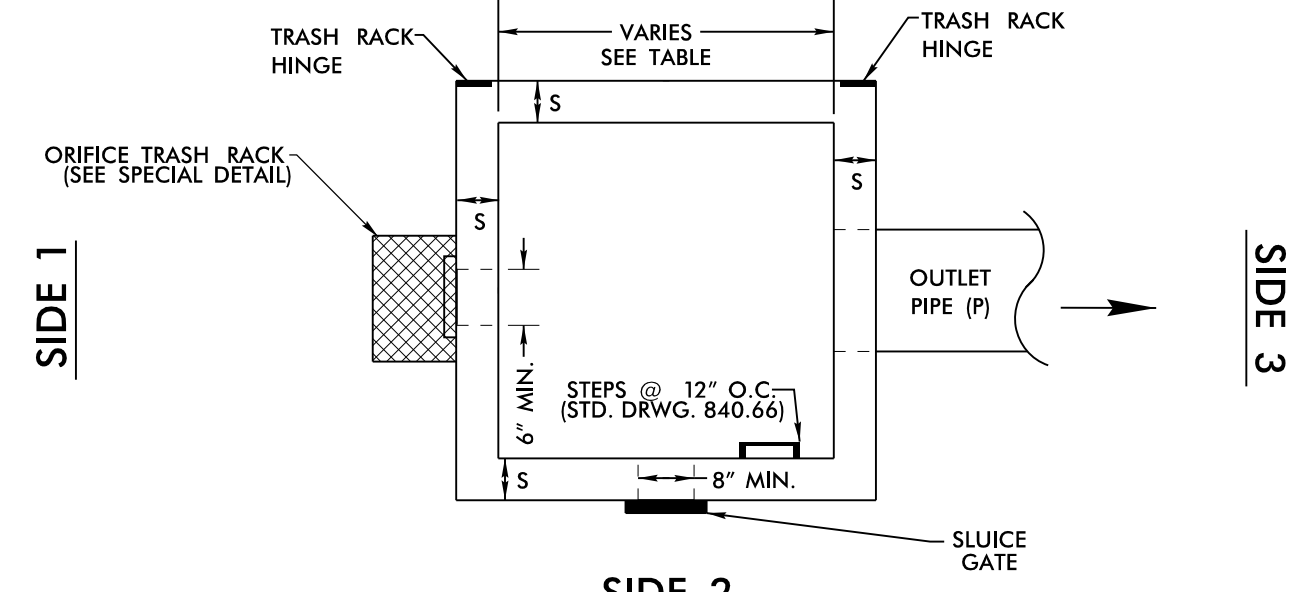

SIDE 2

PLAN VIEW
TRASH RACK NOT SHOWN FOR CLARITY

- NOTES:
1. TOP ELEVATION OF CONTROL STRUCTURE (WEIR ELEVATION) SHOULD BE SET AT THE WQV ELEVATION.
 2. 15" MINIMUM DIAMETER FOR OUTLET PIPE.
 3. 2" MINIMUM DIAMETER ORIFICE. IF ORIFICE IS GREATER THAN 6", A STEEL PLATE IS NOT REQUIRED.
 4. NO BEDDING MATERIAL TO BE USED. THEREFORE, DO NOT FOLLOW STANDARD DRAWINGS FOR METHOD OF PIPE INSTALLATION FOR OUTLET PIPE THROUGH EMBANKMENT.
 5. SLUDGE GATE IS FOR MAINTENANCE AND SHOULD REMAIN CLOSED DURING NORMAL OPERATION. A GATE VALVE MAY BE USED IN LIEU OF THE 8" SLUDGE GATE.
 6. SLUDGE GATE SHALL PROVIDE WATERTIGHT SEAL. PROVIDE ADEQUATE CLEARANCE FOR GATE OPERATION AND FOR PROPER SEATING OF GATE OVER PIPE.
 7. SELECT BOX STANDARD AS REQUIRED TO ACCOMMODATE SLUDGE GATE AND ORIFICE TRASH RACK WIDTH.
 8. ENSURE TRASH RACK OPENS FREELY AND WITHOUT INTERFERENCE WITH SLUDGE GATE.
 9. ADJUST FOOTER DIMENSIONS AS NEEDED FOR ANTI-FLOTATION.
 10. PAYMENT OF TRASH RACKS ARE INCIDENTAL TO BASIN DRAWDOWN STRUCTURE.

MINIMUM DIMENSIONS FOR DRY DETENTION BASIN DRAWDOWN STRUCTURE

STATION	STRUCTURE NUMBER	S (INCHES) 6" MIN.	B (INCHES) 6" MIN.	BASIN BOTTOM MINIMUM ELEV.	TOP ELEVATION CONTROL STRUCTURE	MAX. STORAGE DEPTH(D) FEET	INV. ELEV. CTL. STR.	CTL. STR. DIMENSIONS (W x L x H)	ORIFICE DIAMETER (O) INCHES	ORIFICE INV. ELEV.	OUTLET PIPE DIAMETER(P) INCHES
400+00 -L- LT	0623	6"	18"	940.0	944.0	4.0	938.0	5' X 5' X 6'	6"	940.0	24
400+08 -L- RT	0609	6"	15"	947.0	950.0	3.0	945.0	5' x 5' x 5'	6"	947.0	24